



STX13005

HIGH VOLTAGE FAST-SWITCHING NPN POWER TRANSISTOR

- n HIGH VOLTAGE CAPABILITY
- n LOW SPREAD OF DYNAMIC PARAMETERS
- n MINIMUM LOT-TO-LOT SPREAD FOR RELIABLE OPERATION
- n VERY HIGH SWITCHING SPEED

APPLICATION

- n COMPACT FLUORESCENT LAMPS (CFLS)
- n SWITCH MODE POWER SUPPLIES (AC / DC CONVERTERS)

DESCRIPTION

The device is manufactured using high voltage Multi-Epitaxial Planar technology for high switching speeds and high voltage capability.

It uses a Cellular Emitter structure with planar edge termination to enhance switching speeds while maintaining a wide RBSOA.

Figure 1: Package

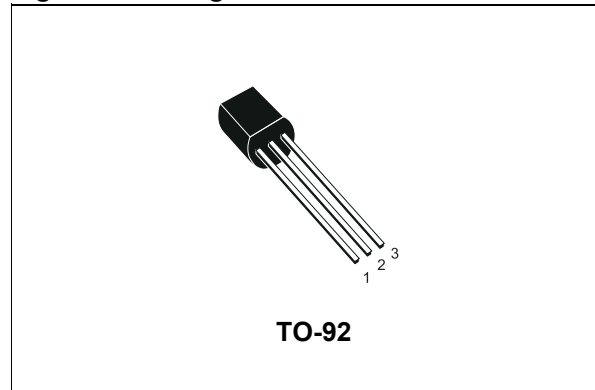

Figure 2: Internal Schematic Diagram

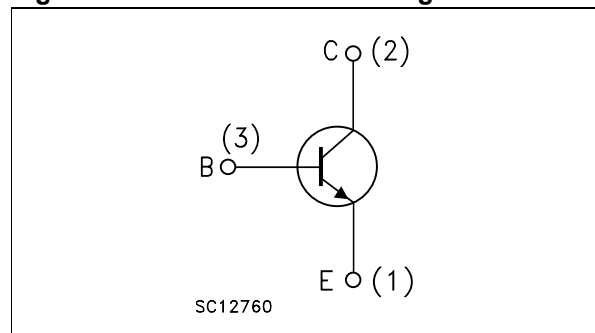

Table 1: Order Code

Part Number	Marking	Package	Packaging
STX13005	X13005	TO-92	Bulk
STX13005-AP	X13005	TO-92 AP	Ammopack

Table 2: Absolute Maximum Ratings

Symbol	Parameter	Value	Unit
V_{CES}	Collector-Emitter Voltage ($V_{BE} = 0$)	700	V
V_{CEO}	Collector-Emitter Voltage ($I_B = 0$)	400	V
V_{EBO}	Emitter-Base Voltage ($I_C = 0$, $I_B = 1.5$ A, $t_p < 10$ ms)	$V_{(BR)EBO}$	V
I_C	Collector Current	3	A
I_{CM}	Collector Peak Current ($t_p < 5$ ms)	6	A
I_B	Base Current	1.5	A
I_{BM}	Base Peak Current ($t_p < 5$ ms)	3	A
P_{tot}	Total Dissipation at $T_C = 25$ °C	2.8	W

STX13005

Symbol	Parameter	Value	Unit
T_{stg}	Storage Temperature	-65 to 150	°C
T_J	Max. Operating Junction Temperature	150	°C

Table 3: Thermal Data

Symbol	Parameter	Value	Unit
$R_{thj-case}$	Thermal Resistance Junction-Case Max	44.6	°C/W
$R_{thj-amb}$	Thermal Resistance Junction-ambient Max	150	°C/W

Table 4: Electrical Characteristics ($T_{case} = 25\text{ °C}$ unless otherwise specified)

Symbol	Parameter	Test Conditions	Min.	Typ.	Max.	Unit
I_{CES}	Collector Cut-off Current ($V_{BE} = 0$)	$V_{CE} = 700\text{ V}$			1	mA
		$V_{CE} = 700\text{ V}$ $T_J = 125\text{ °C}$			5	mA
I_{CEO}	Collector Cut-off Current ($I_B = 0$)	$V_{CE} = 400\text{ V}$			1	mA
$V_{(BR)EBO}$	Emitter-Base Breakdown Voltage ($I_C = 0$)	$I_E = 10\text{ mA}$ $L = 25\text{ mH}$	9		18	V
$V_{CE(sus)}^*$	Collector-Emitter Sustaining Voltage ($I_B = 0$)	$I_C = 10\text{ mA}$	400			V
$V_{CE(sat)}^*$	Collector-Emitter Saturation Voltage	$I_C = 1\text{ A}$ $I_B = 200\text{ mA}$			0.5	V
		$I_C = 2\text{ A}$ $I_B = 500\text{ mA}$			0.6	V
		$I_C = 3\text{ A}$ $I_B = 750\text{ mA}$			5	V
$V_{BE(sat)}^*$	Base-Emitter Saturation Voltage	$I_C = 1\text{ A}$ $I_B = 200\text{ mA}$			1.2	V
		$I_C = 2\text{ A}$ $I_B = 500\text{ mA}$			1.6	V
h_{FE}^*	DC Current Gain	$I_C = 1\text{ A}$ $V_{CE} = 5\text{ V}$	10		30	
		$I_C = 2\text{ A}$ $V_{CE} = 5\text{ V}$	8		24	
t_s t_f	RESISTIVE LOAD	$I_C = 2\text{ A}$ $V_{CC} = 125\text{ V}$ $I_{B1} = -I_{B2} = 400\text{ mA}$ $t_p = 30\text{ }\mu\text{s}$ (see figure 16)		1.65 260		μs ns
	INDUCTIVE LOAD	$I_C = 1\text{ A}$ $I_{B1} = 200\text{ mA}$ $L = 50\text{ mH}$ (see figure 15)		0.8 150		μs ns

* Pulsed: Pulsed duration = 300 μs , duty cycle $\leq 1.5\%$.

Figure 3: Safe Operating Area

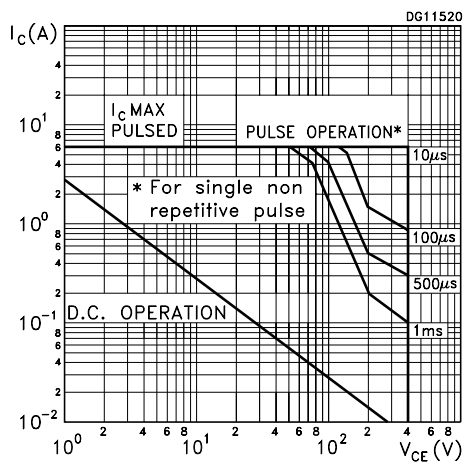

Figure 4: Output Characteristics

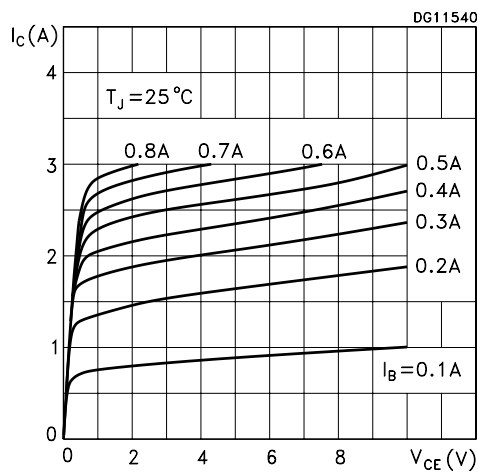

Figure 5: DC Current Gain

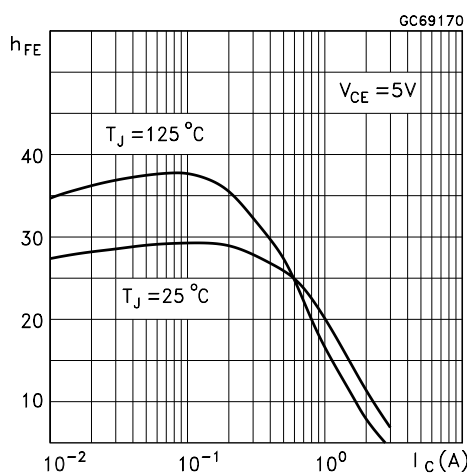

Figure 6: Derating Curve

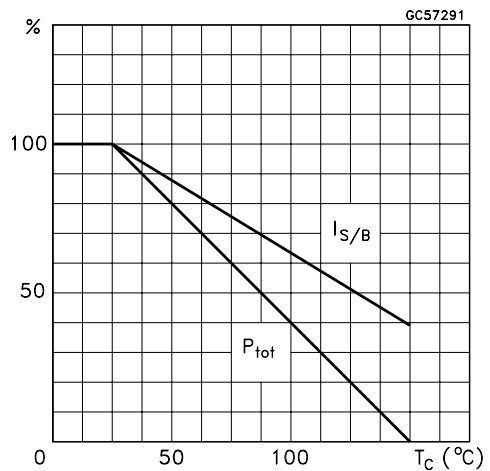

Figure 7: DC Current Gain

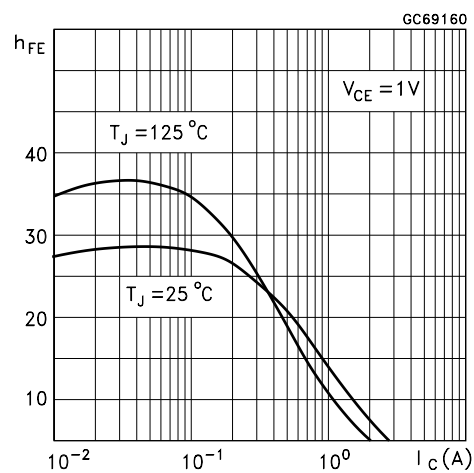

Figure 8: Collector-Emitter Saturation Voltage

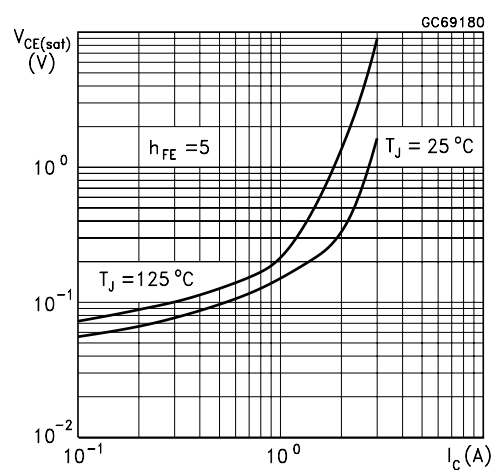

Figure 9: Base-Emitter Saturation Voltage

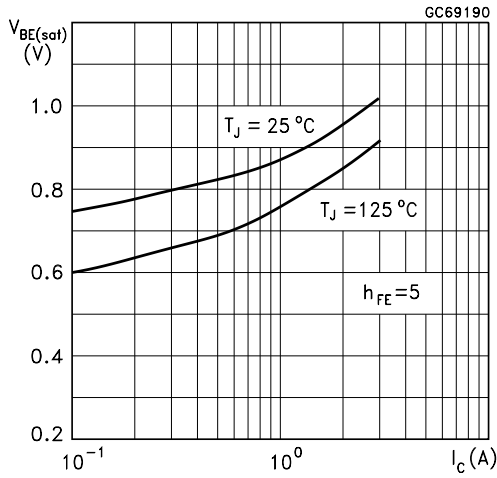

Figure 10: Resistive Load Fall Time

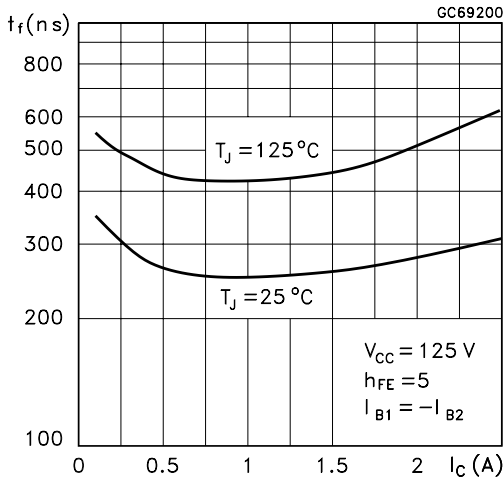

Figure 11: Inductive Load Fall Time

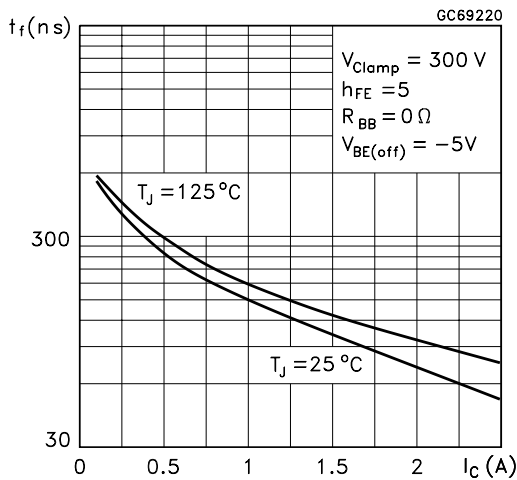

Figure 12: Resistive Load Storage Time

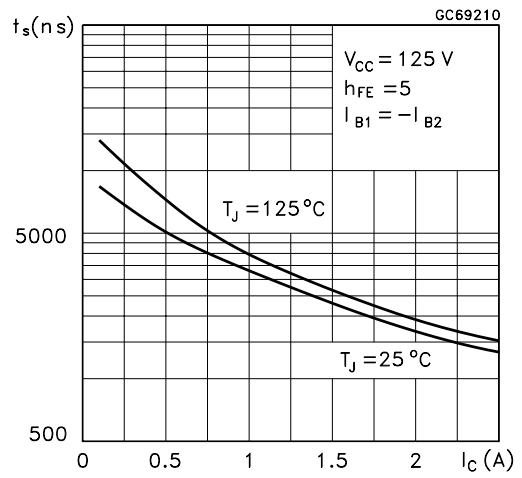

Figure 13: Inductive Load Storage Time

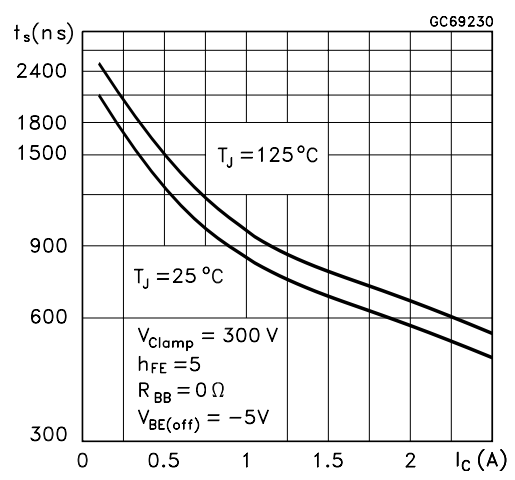

Figure 14: Reverse Biased Safe Operating Area

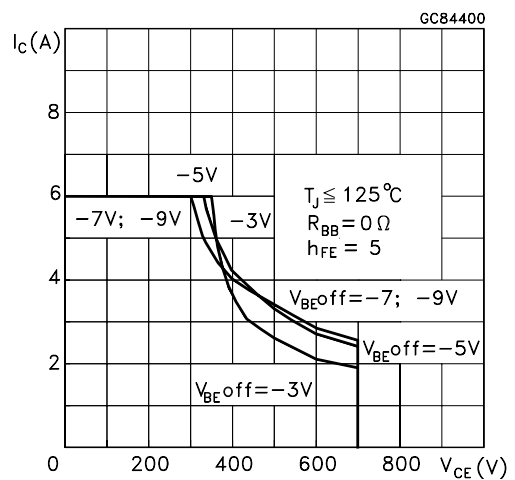

Figure 15: Inductive Load Switching Test Circuit

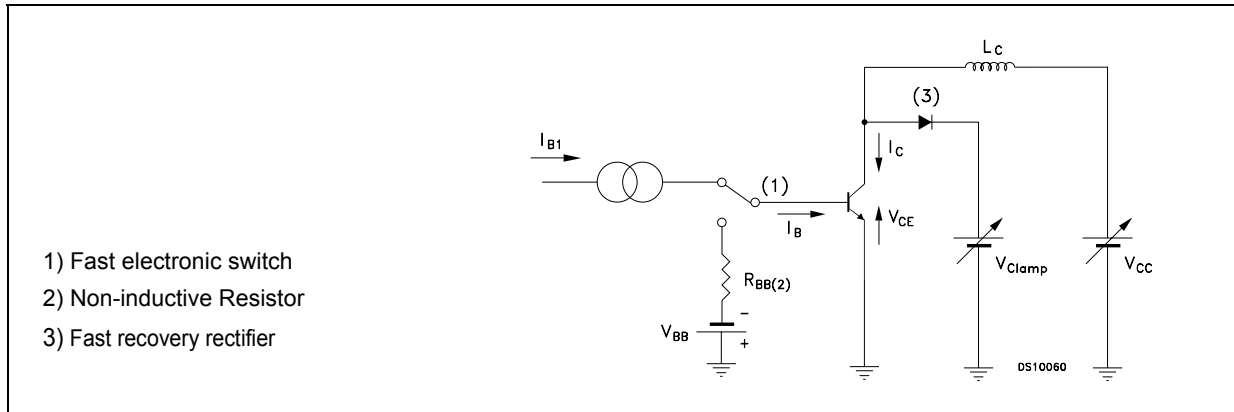
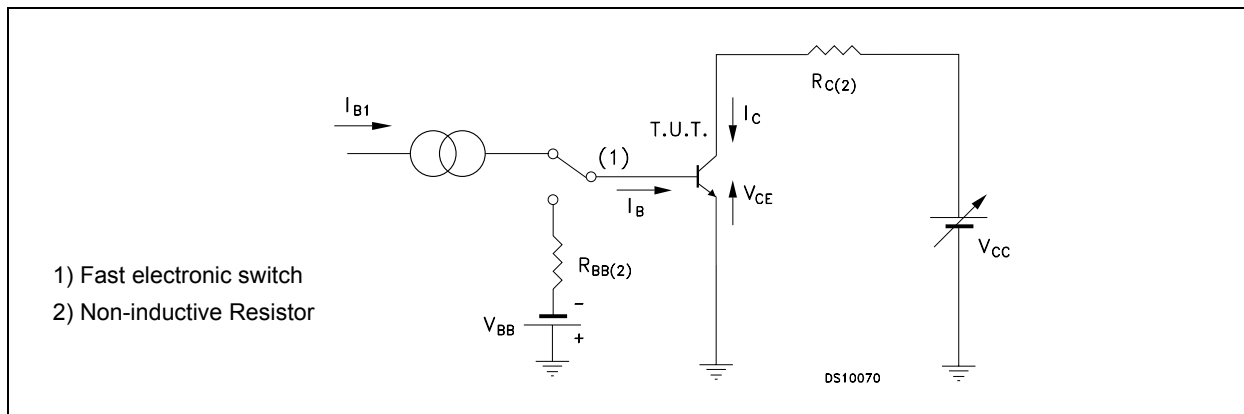
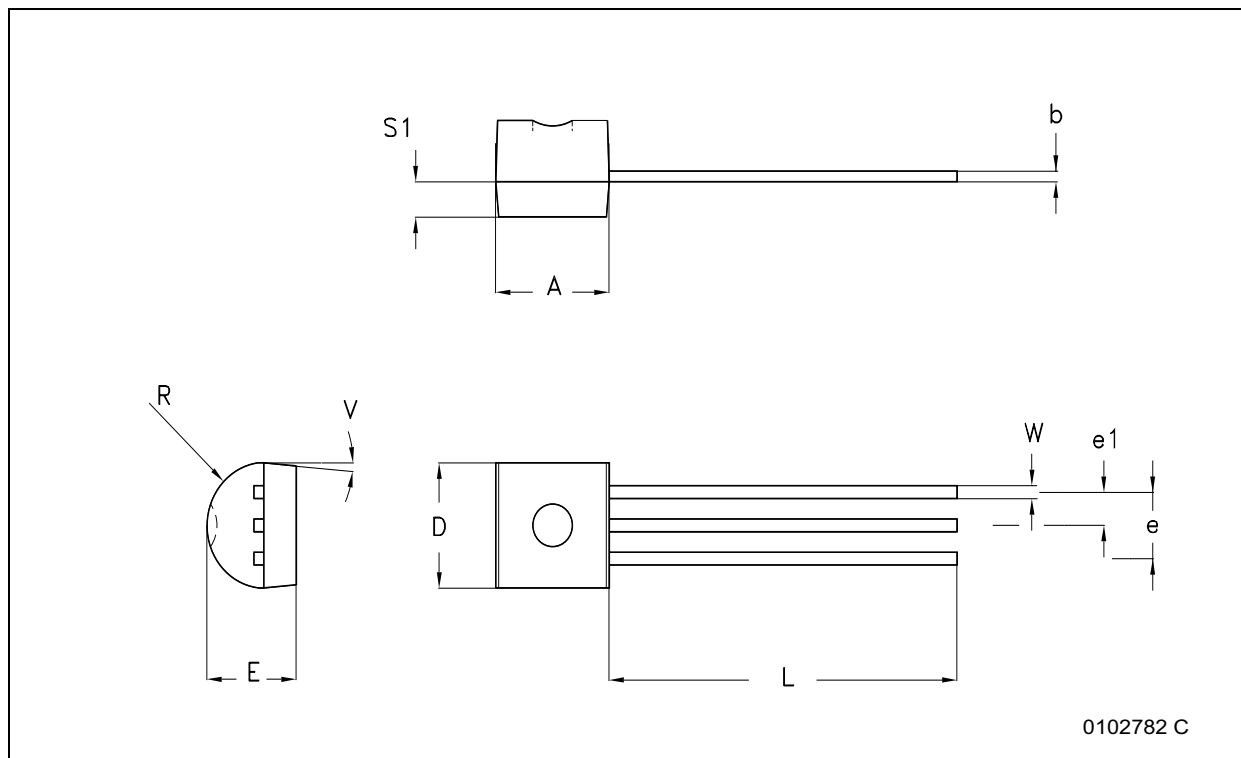

Table 16: Resistive Load Switching Test Circuit



TO-92 BULK SHIPMENT MECHANICAL DATA

DIM.	mm.		
	MIN.	TYP	MAX.
A	4.32		4.95
b	0.36		0.51
D	4.45		4.95
E	3.30		3.94
e	2.41		2.67
e1	1.14		1.40
L	12.70		15.49
R	2.16		2.41
S1	0.92		1.52
W	0.41		0.56
V		5°	



TO-92 AMMOPACK SHIPMENT (Suffix"-AP") MECHANICAL DATA

DIM.	mm.		
	MIN.	TYP	MAX.
A1			4.80
T			3.80
T1			1.60
T2			2.30
d			0.48
P0	12.50	12.70	12.90
P2	5.65	6.35	7.05
F1,F2	2.44	2.54	2.94
delta H	-2.00		2.00
W	17.50	18.00	19.00
W0	5.70	6.00	6.30
W1	8.50	9.00	9.25
W2			0.50
H	18.50		20.50
H0	15.50	16.00	16.50
H1			25.00
D0	3.80	4.00	4.20
t			0.90
L			11.00
I1	3.00		
delta P	-1.00		1.00

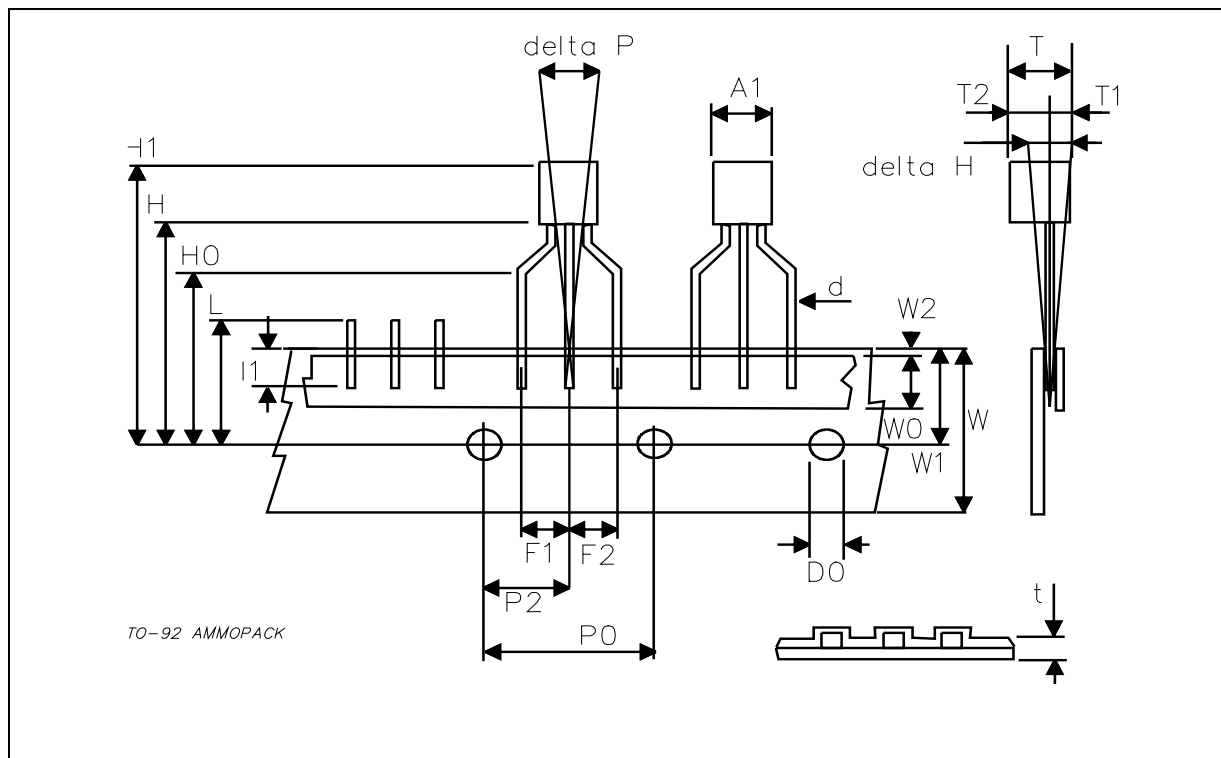

Table 5: Revision History

Date	Release	Change Designator
01-Jul-2004	1	First Release.
11-Feb-2005	2	New table on page 1.

Information furnished is believed to be accurate and reliable. However, STMicroelectronics assumes no responsibility for the consequences of use of such information nor for any infringement of patents or other rights of third parties which may result from its use. No license is granted by implication or otherwise under any patent or patent rights of STMicroelectronics. Specifications mentioned in this publication are subject to change without notice. This publication supersedes and replaces all information previously supplied. STMicroelectronics products are not authorized for use as critical components in life support devices or systems without express written approval of STMicroelectronics.

The ST logo is a registered trademark of STMicroelectronics

All other names are the property of their respective owners

© 2005 STMicroelectronics - All Rights Reserved

STMicroelectronics group of companies

Australia - Belgium - Brazil - Canada - China - Czech Republic - Finland - France - Germany - Hong Kong - India - Israel - Italy - Japan -
Malaysia - Malta - Morocco - Singapore - Spain - Sweden - Switzerland - United Kingdom - United States of America

www.st.com