



# ULQ2001A - ULQ2003A ULQ2002A - ULQ2004A

## SEVEN DARLINGTON ARRAYS

- SEVEN DARLINGTONS PER PACKAGE
- **EXTENDED TEMPERATURE RANGE**  
(-40 to 105°C)
- OUTPUT CURRENT 500 mA PER DRIVER  
(600 mA PEAK)
- OUTPUT VOLTAGE 50 V
- INTEGRAL SUPPRESSION DIODES FOR INDUCTIVE LOADS
- OUTPUTS CAN BE PARALLELED FOR HIGHER CURRENT
- TTL/CMOS/PMOS/DTL COMPATIBLE INPUTS
- INPUTS PINNED OPPOSITE OUTPUTS TO SIMPLIFY LAYOUT

### DESCRIPTION

The ULQ2001A, ULQ2002A, ULQ2003 and ULQ2004A are high voltage, high current darlington arrays each containing seven open collector darlington pairs with common emitters. Each channel is rated at 500 mA and can withstand peak currents of 600 mA. Suppression diodes are included for inductive load driving and the inputs are pinned opposite the outputs to simplify board layout.

The four versions interface to all common logic families :

ULQ2001A	General Purpose, DTL, TTL, PMOS, CMOS
ULQ2002A	14-25V PMOS
ULQ2003A	5V TTL, CMOS
ULQ2004A	6-15V CMOS, PMOS

These versatile devices are useful for driving a wide range of loads including solenoids, relays DC motors, LED displays filament lamps, thermal print-heads and high power buffers.

The ULQ2001A/2002A/2003A and 2004A are supplied in 16 pin plastic DIP packages with a copper leadframe to reduce thermal resistance. They are available also in small outline package (SO-16) as ULQ2001D1/2002D1/2003D1/2004D1.

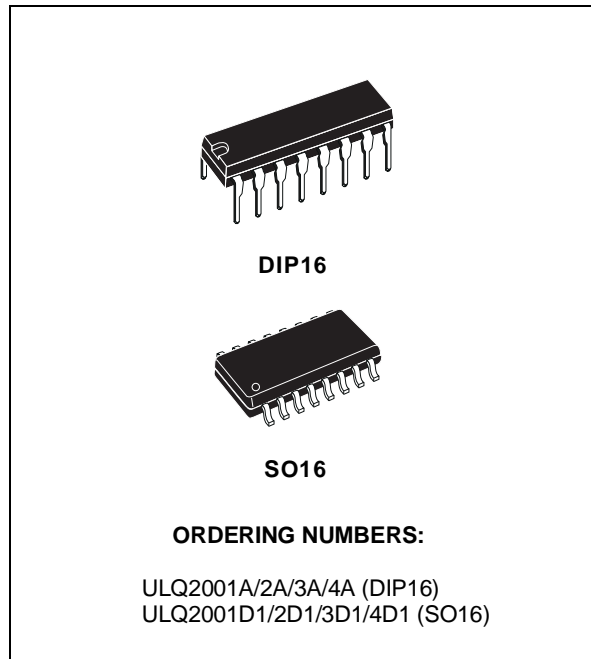

### PIN CONNECTION

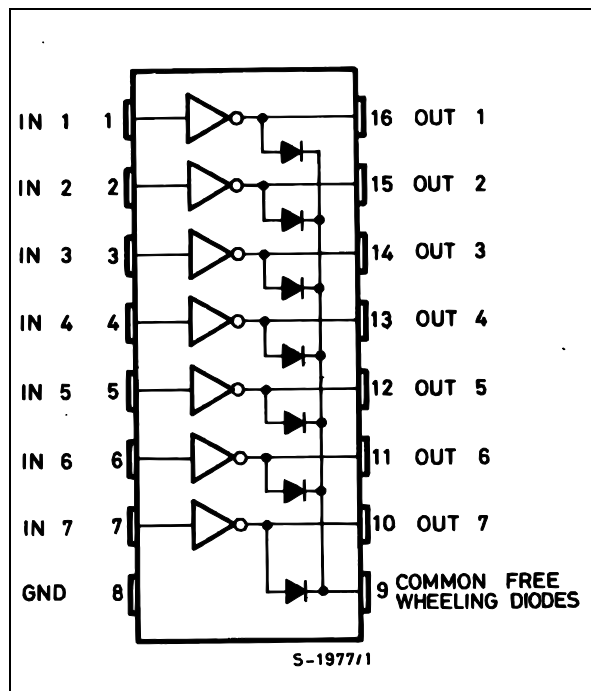

# ULQ2001A - ULQ2002A - ULQ2003A - ULQ2004A

## SCHEMATIC DIAGRAM

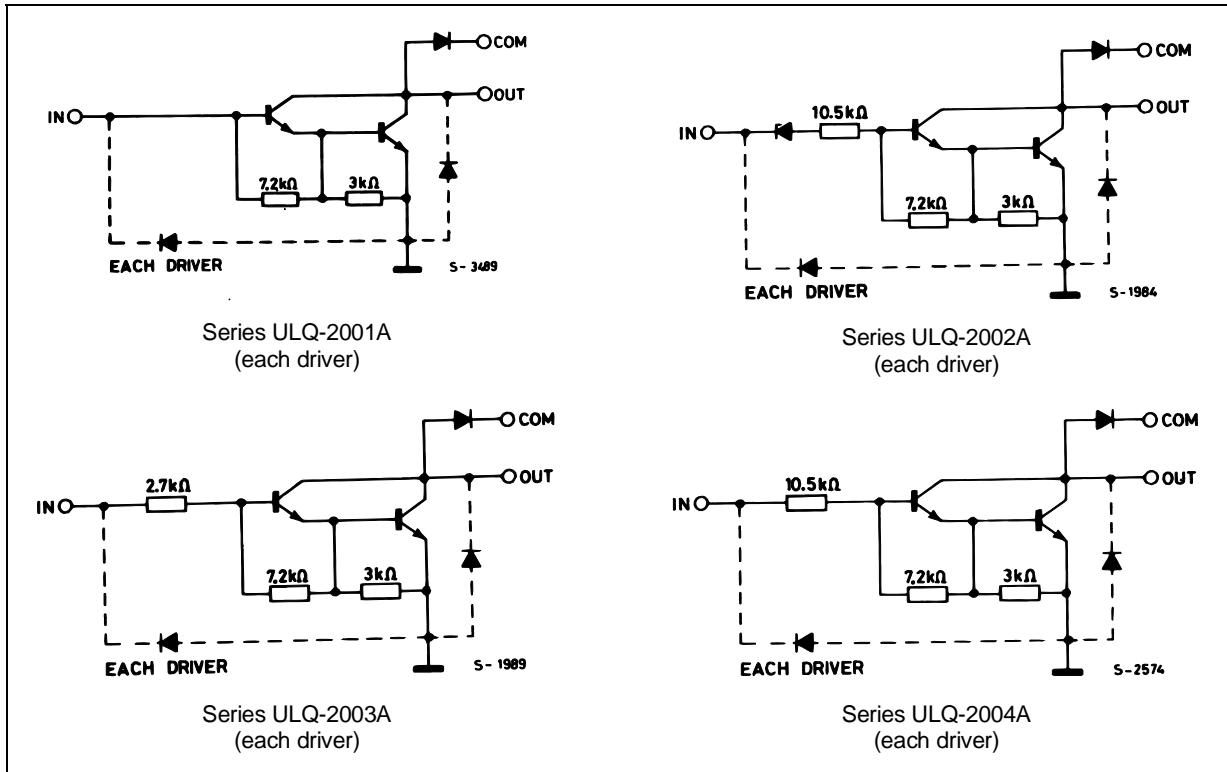

## ABSOLUTE MAXIMUM RATINGS

Symbol	Parameter	Value	Unit
$V_o$	Output Voltage	50	V
$V_{in}$	Input Voltage (for ULQ2002A/D1 - 2003A/D1 - 2004A/D1)	30	V
$I_c$	Continuous Collector Current	500	mA
$I_b$	Continuous Base Current	25	mA
$T_{amb}$	Operating Ambient Temperature Range	-40 to 105	°C
$T_{stg}$	Storage Temperature Range	-55 to 150	°C
$T_j$	Junction Temperature	150	°C

## THERMAL DATA

Symbol	Parameter	DIP16	SO16	Unit
$R_{th\ j-amb}$	Thermal Resistance Junction-ambient	Max. 70	120	°C/W

**ULQ2001A - ULQ2002A - ULQ2003A - ULQ2004A**

**ELECTRICAL CHARACTERISTICS** ( $T_J = -40$  to  $105^\circ\text{C}$  for DIP16 unless otherwise specified)  
 ( $T_J = 25$  to  $105^\circ\text{C}$  for SO16 unless otherwise specified)

Symbol	Parameter	Test Conditions	Min.	Typ.	Max.	Unit	Fig.
$I_{CEX}$	Output Leakage Current	$V_{CE} = 50\text{V}$ $T_J = 105^\circ\text{C}$ , $V_{CE} = 50\text{V}$ $T_J = 105^\circ\text{C}$ for <b>ULQ2002A</b> $V_{CE} = 50\text{V}$ , $V_i = 6\text{V}$ for <b>ULQ2004A</b> $V_{CE} = 50\text{V}$ , $V_i = 1\text{V}$			50 100	$\mu\text{A}$ $\mu\text{A}$	1a 1a
					500 500	$\mu\text{A}$ $\mu\text{A}$	1b 1b
$V_{CE(sat)}$	Collector-emitter Saturation Voltage	$I_C = 100\text{mA}$ , $I_B = 250\mu\text{A}$ $I_C = 200\text{mA}$ , $I_B = 350\mu\text{A}$ $I_C = 350\text{mA}$ , $I_B = 500\mu\text{A}$		0.9	1.1	V	2
				1.1	1.3	V	2
				1.3	1.6	V	2
$I_{i(on)}$	Input Current	for <b>ULQ2002A</b> $V_i = 17\text{V}$ for <b>ULQ2003A</b> $V_i = 3.85\text{V}$ for <b>ULQ2004A</b> $V_i = 5\text{V}$ $V_i = 12\text{V}$		0.82	1.25	mA	3
				0.93	1.35	mA	3
				0.35	0.5	mA	3
				1	1.45	mA	3
$I_{i(off)}$	Input Current	$T_J = 105^\circ\text{C}$ , $I_C = 500\mu\text{A}$	50	65		$\mu\text{A}$	4
$V_{i(on)}$	Input Voltage	for <b>ULQ2002A</b> $V_{CE} = 2\text{V}$ , $I_C = 300\text{mA}$ for <b>ULQ2003A</b> $V_{CE} = 2\text{V}$ , $I_C = 200\text{mA}$ $V_{CE} = 2\text{V}$ , $I_C = 250\text{mA}$ for <b>ULQ2004A</b> $V_{CE} = 2\text{V}$ , $I_C = 300\text{mA}$ $V_{CE} = 2\text{V}$ , $I_C = 125\text{mA}$ $V_{CE} = 2\text{V}$ , $I_C = 200\text{mA}$ $V_{CE} = 2\text{V}$ , $I_C = 275\text{mA}$ $V_{CE} = 2\text{V}$ , $I_C = 350\text{mA}$			13	V	5
					2.4	V	5
					2.7	V	5
					3	V	5
					5	V	5
					6	V	5
					7	V	5
					8	V	5
$h_{FE}$	DC Forward Current Gain	for <b>ULQ2001A</b> $V_{CE} = 2\text{V}$ , $I_C = 350\text{mA}$	1000			–	2
$C_i$	Input Capacitance			15	25 (*)	pF	–
$t_{PLH}$	Turn-on Delay Time	$0.5 V_i$ to $0.5 V_o$		0.25	1 (*)	$\mu\text{s}$	–
$t_{PHL}$	Turn-off Delay Time	$0.5 V_i$ to $0.5 V_o$		0.25	1 (*)	$\mu\text{s}$	–
$I_R$	Clamp Diode Leakage Current	$V_R = 50\text{V}$ $T_J = 105^\circ\text{C}$ , $V_R = 50\text{V}$			50	$\mu\text{A}$	6
					100	$\mu\text{A}$	6
$V_F$	Clamp Diode Forward Voltage	$I_F = 350\text{mA}$		1.7	2	V	7

(\*) Guaranteed by design

DIM.	mm			inch		
	MIN.	TYP.	MAX.	MIN.	TYP.	MAX.
A			1.75			0.069
a1	0.1		0.25	0.004		0.009
a2			1.6			0.063
b	0.35		0.46	0.014		0.018
b1	0.19		0.25	0.007		0.010
C		0.5			0.020	
c1	45° (typ.)					
D (1)	9.8		10	0.386		0.394
E	5.8		6.2	0.228		0.244
e		1.27			0.050	
e3		8.89			0.350	
F (1)	3.8		4	0.150		0.157
G	4.6		5.3	0.181		0.209
L	0.4		1.27	0.016		0.050
M			0.62			0.024
S	8°(max.)					

**OUTLINE AND MECHANICAL DATA**

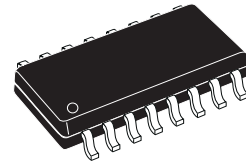

**SO16 Narrow**

(1) D and F do not include mold flash or protrusions. Mold flash or protrusions shall not exceed 0.15mm (.006inch).

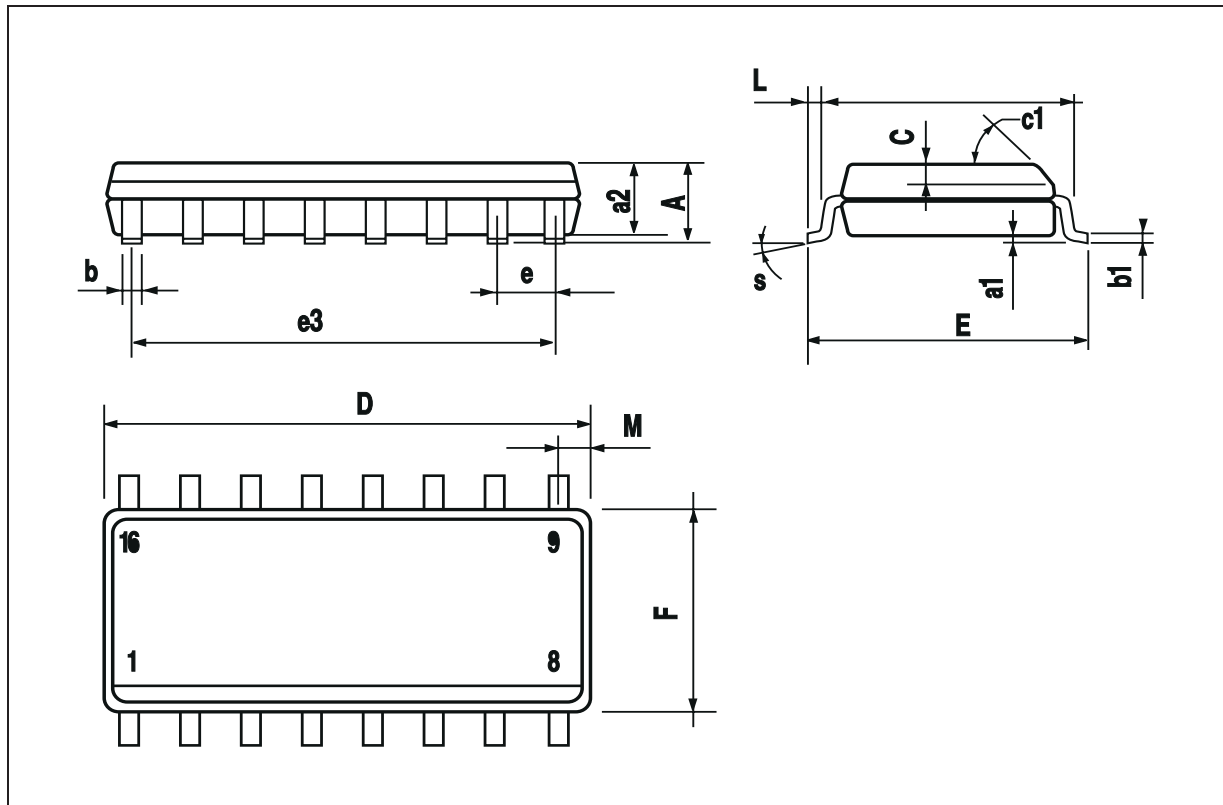

ULQ2001A - ULQ2002A - ULQ2003A - ULQ2004A

DIM.	mm			inch		
	MIN.	TYP.	MAX.	MIN.	TYP.	MAX.
a1	0.51			0.020		
B	0.77		1.65	0.030		0.065
b		0.5			0.020	
b1		0.25			0.010	
D			20			0.787
E		8.5			0.335	
e		2.54			0.100	
e3		17.78			0.700	
F			7.1			0.280
I			5.1			0.201
L		3.3			0.130	
Z			1.27			0.050

OUTLINE AND MECHANICAL DATA

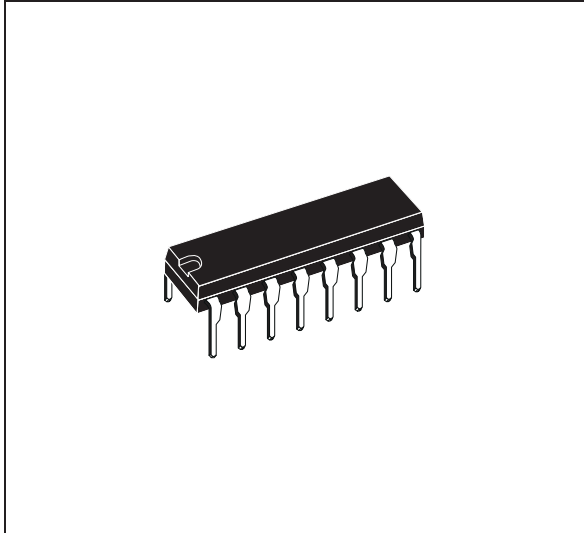

DIP16

