



# 12-Bit, 40MHz Sampling ANALOG-TO-DIGITAL CONVERTER

## FEATURES

- LOW POWER: 390mW
- INTERNAL REFERENCE
- WIDEBAND TRACK-AND-HOLD: 65MHz
- SINGLE +5V SUPPLY

## APPLICATIONS

- IF AND BASEBAND DIGITIZATION
- DIGITAL COMMUNICATIONS
- ULTRASOUND IMAGING
- GAMMA CAMERAS
- TEST INSTRUMENTATION
- CCD IMAGING
  - Copiers
  - Scanners
  - Cameras
- VIDEO DIGITIZING

## DESCRIPTION

The ADS800 is a low-power, monolithic 12-bit, 40MHz Analog-to-Digital (A/D) converter utilizing a small geometry CMOS process. This complete converter includes a 12-bit quantizer, wideband track-and-hold, reference, and three-state outputs. It operates from a single +5V power supply and can be configured to accept either differential or single-ended input signals.

The ADS800 employs digital error correction to provide excellent Nyquist differential linearity performance for demanding imaging applications. Its low distortion, high SNR, and high oversampling capability give it the extra margin needed for telecommunications, test instrumentation, and video applications.

This high-performance A/D converter is specified over temperature for AC and DC performance at a 40MHz sampling rate. The ADS800 is available in an SO-28 package.

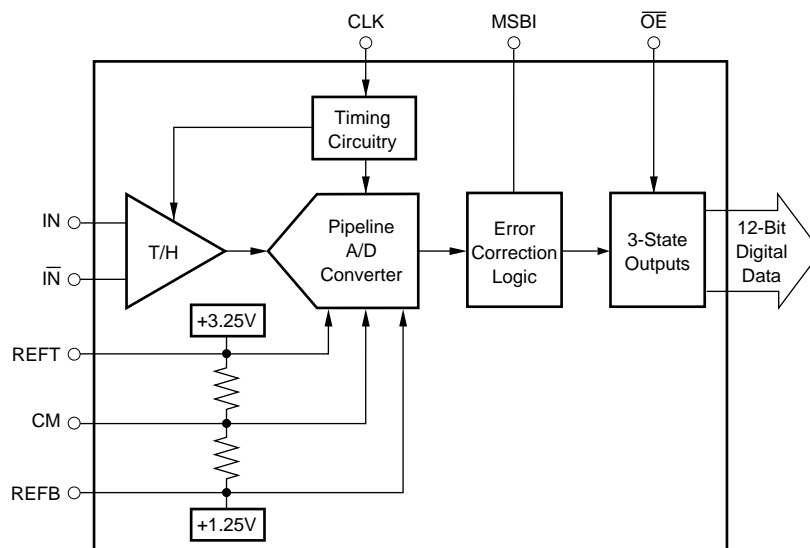

Please be aware that an important notice concerning availability, standard warranty, and use in critical applications of Texas Instruments semiconductor products and disclaimers thereto appears at the end of this data sheet.

All trademarks are the property of their respective owners.

## ABSOLUTE MAXIMUM RATINGS<sup>(1)</sup>

+V <sub>S</sub> .....	+6V
Analog Input .....	0V to (+V <sub>S</sub> + 300mV)
Logic Input .....	0V to (+V <sub>S</sub> + 300mV)
Case Temperature .....	+100°C
Junction Temperature .....	+150°C
Storage Temperature .....	+125°C
External Top Reference Voltage (REFT) .....	+3.4V Max
External Bottom Reference Voltage (REFB) .....	+1.1V Min

NOTE: (1) Stresses above these ratings may permanently damage the device.



## ELECTROSTATIC DISCHARGE SENSITIVITY

This integrated circuit can be damaged by ESD. Texas Instruments recommends that all integrated circuits be handled with appropriate precautions. Failure to observe proper handling and installation procedures can cause damage.

ESD damage can range from subtle performance degradation to complete device failure. Precision integrated circuits may be more susceptible to damage because very small parametric changes could cause the device not to meet its published specifications.

## PACKAGE/ORDERING INFORMATION<sup>(1)</sup>

PRODUCT	PACKAGE-LEAD	PACKAGE DESIGNATOR	SPECIFIED TEMPERATURE RANGE	PACKAGE MARKING	ORDERING NUMBER	TRANSPORT MEDIA, QUANTITY
ADS800U	SO-28	DW	-40°C to +85°C	ADS800U	ADS800U	Rails, 28

NOTE: (1) For the most current package and ordering information, see the Package Option Addendum at the end of this document, or see the TI website at [www.ti.com](http://www.ti.com).

## ELECTRICAL CHARACTERISTICS

At T<sub>A</sub> = +25°C, V<sub>S</sub> = +5V, Sampling Rate = 40MHz, and with a 50% duty cycle clock having a 2ns rise-and-fall time, unless otherwise noted.

PARAMETER	CONDITIONS	TEMP	ADS800U			UNITS
			MIN	TYP	MAX	
Resolution				12		Bits
Specified Temperature Range	T <sub>AMBIENT</sub>		0		+70	°C
Operating Temperature Range	T <sub>AMBIENT</sub>		-40		+85	°C
<b>ANALOG INPUT</b>						
Differential Full-Scale Input Range	Both Inputs, 180° Out-of-Phase		+1.25		+3.25	V
Common-Mode Voltage				+2.25		V
Analog Input Bandwidth (-3dB)						
Small-Signal	-20dBFS <sup>(1)</sup> Input	+25°C		400		MHz
Full-Power	0dBFS Input	+25°C		65		MHz
Input Impedance				1.25    4		MΩ    pF
<b>DIGITAL INPUT</b>						
Logic Family			TTL/HCT Compatible CMOS			
Convert Command	Start Conversion			Falling Edge		
<b>ACCURACY<sup>(2)</sup></b>						
Gain Error		f <sub>S</sub> = 2.5MHz +25°C Full		±0.4 ±0.6	±1.5 ±2.5	% %
Gain Drift				±95		ppm/°C
Power-Supply Rejection of Gain	Δ +V <sub>S</sub> = ±5%	+25°C		0.01	0.15	%FSR/%
Input Offset Error		Full		±2.6	±3.5	%
Power-Supply Rejection of Offset	Δ +V <sub>S</sub> = ±5%	+25°C		0.02	0.15	%FSR/%
<b>CONVERSION CHARACTERISTICS</b>						
Sample Rate			10k		40M	Sample/s
Data Latency				6.5		Convert Cycle
<b>DYNAMIC CHARACTERISTICS</b>						
Differential Linearity Error						
f = 500kHz	t <sub>H</sub> = 13ns <sup>(3)</sup>	+25°C Full		±0.6 ±0.8	±1.0	LSB LSB
f = 12MHz		+25°C Full		±0.4 ±0.5	±1.0	LSB LSB
No Missing Codes	t <sub>H</sub> = 13ns <sup>(3)</sup>	+25°C		Tested		LSB
Integral Linearity Error at f = 500kHz		Full		±1.9		LSB
Spurious-Free Dynamic Range (SFDR)						
f = 500kHz (-1dBFS input)		+25°C Full	65 60	72 66		dBFS dBFS
f = 12MHz (-1dBFS input)		+25°C Full	58 55	61 61		dBFS dBFS

NOTES: (1) dBFS refers to dB below Full-Scale. (2) Percentage accuracies are referred to the internal A/D converter Full-Scale Range of 4Vp-p. (3) To assure DNL and no missing code performance, see timing diagram footnote 2. (4) IMD is referred to the larger of the two input signals. If referred to the peak envelope signal (=0dB), the intermodulation products will be 7dB lower. (5) No "rollover" of bits.

# ELECTRICAL CHARACTERISTICS (Cont.)

At  $T_A = +25^\circ\text{C}$ ,  $V_S = +5\text{V}$ , Sampling Rate = 40MHz, and with a 50% duty cycle clock having a 2ns rise-and-fall time, unless otherwise noted.

PARAMETER	CONDITIONS	TEMP	ADS800U			UNITS	
			MIN	TYP	MAX		
<b>DYNAMIC CHARACTERISTICS (Cont.)</b>							
2-Tone Intermodulation Distortion (IMD) <sup>(4)</sup> f = 4.4MHz and 4.5MHz (–7dBFS each tone)		+25°C Full		–63 –62		dBc dBc	
Signal-to-Noise Ratio (SNR) f = 500kHz (–1dBFS input)		+25°C Full	61 57	64 63		dB dB	
f = 12MHz (–1dBFS input)		+25°C Full	61 56	62 62		dB dB	
Signal-to-(Noise + Distortion) (SINAD) f = 500kHz (–1dBFS input)		+25°C Full	59 54	63 64		dB dB	
f = 12MHz (–1dBFS input)		+25°C Full	56 51	58 57		dB dB	
Differential Gain Error	NTSC or PAL	+25°C		0.5		%	
Differential Phase Error	NTSC or PAL	+25°C		0.1		degrees	
Aperture Delay Time		+25°C		2		ns	
Aperture Jitter		+25°C		7		ps rms	
Over-Voltage Recovery Time <sup>(5)</sup>	1.5x Full-Scale Input	+25°C		2		ns	
<b>OUTPUTS</b>							
Logic Family Logic Coding Logic Levels	Logic "LO", $C_L = 15\text{pF max}$ Logic "HI", $C_L = 15\text{pF max}$	Logic Selectable Full	0	TTL/HCT Compatible CMOS SOB or BTC		0.4	V
3-State Enable Time		Full	+2.5			+ $V_S$	V
3-State Disable Time		Full		20	40		ns
		Full		2	10		ns
<b>POWER-SUPPLY REQUIREMENTS</b>							
Supply Voltage: + $V_S$	Operating	Full	+4.75	+5.0	+5.25		V
Supply Current: + $I_S$	Operating	+25°C		78	93		mA
	Operating	Full		78	97		mA
Power Consumption	Operating	+25°C		390	465		mW
	Operating	Full		390	485		mW
Thermal Resistance, $\theta_{JA}$ SO-28				75			°C/W

NOTES: (1) dBFS refers to dB below Full-Scale. (2) Percentage accuracies are referred to the internal A/D converter Full-Scale Range of 4Vp-p. (3) To assure DNL and no missing code performance, see timing diagram footnote 2. (4) IMD is referred to the larger of the two input signals. If referred to the peak envelope signal (=0dB), the intermodulation products will be 7dB lower. (5) No "rollover" of bits.

## PIN CONFIGURATION

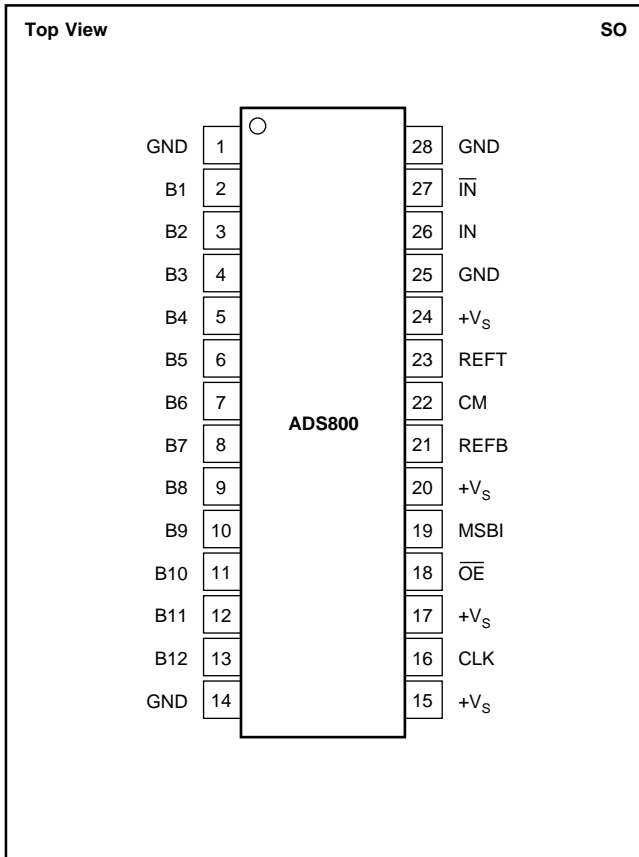

## PIN DESCRIPTIONS

PIN	DESIGNATOR	DESCRIPTION
1	GND	Ground
2	B1	Bit 1, Most Significant Bit
3	B2	Bit 2
4	B3	Bit 3
5	B4	Bit 4
6	B5	Bit 5
7	B6	Bit 6
8	B7	Bit 7
9	B8	Bit 8
10	B9	Bit 9
11	B10	Bit 10
12	B11	Bit 11
13	B12	Bit 12, Least Significant Bit
14	GND	Ground
15	+V <sub>S</sub>	+5V Power Supply
16	CLK	Convert Clock Input, 50% Duty Cycle
17	+V <sub>S</sub>	+5V Power Supply
18	OE	HI: High Impedance State. LO or Floating: Normal Operation. Internal pull-down resistors.
19	MSBI	Most Significant Bit Inversion, HI: MSB inverted for complementary output. LO or Floating: Straight output. Internal pull-down resistors.
20	+V <sub>S</sub>	+5V Power Supply
21	REFB	Bottom Reference Bypass. For external bypassing of internal +1.25V reference.
22	CM	Common-Mode Voltage. It is derived by (REFT + REFB)/2.
23	REFT	Top Reference Bypass. For external bypassing of internal +3.25V reference.
24	+V <sub>S</sub>	+5V Power Supply
25	GND	Ground
26	IN	Input
27	IN	Complementary Input
28	GND	Ground

## TIMING DIAGRAM

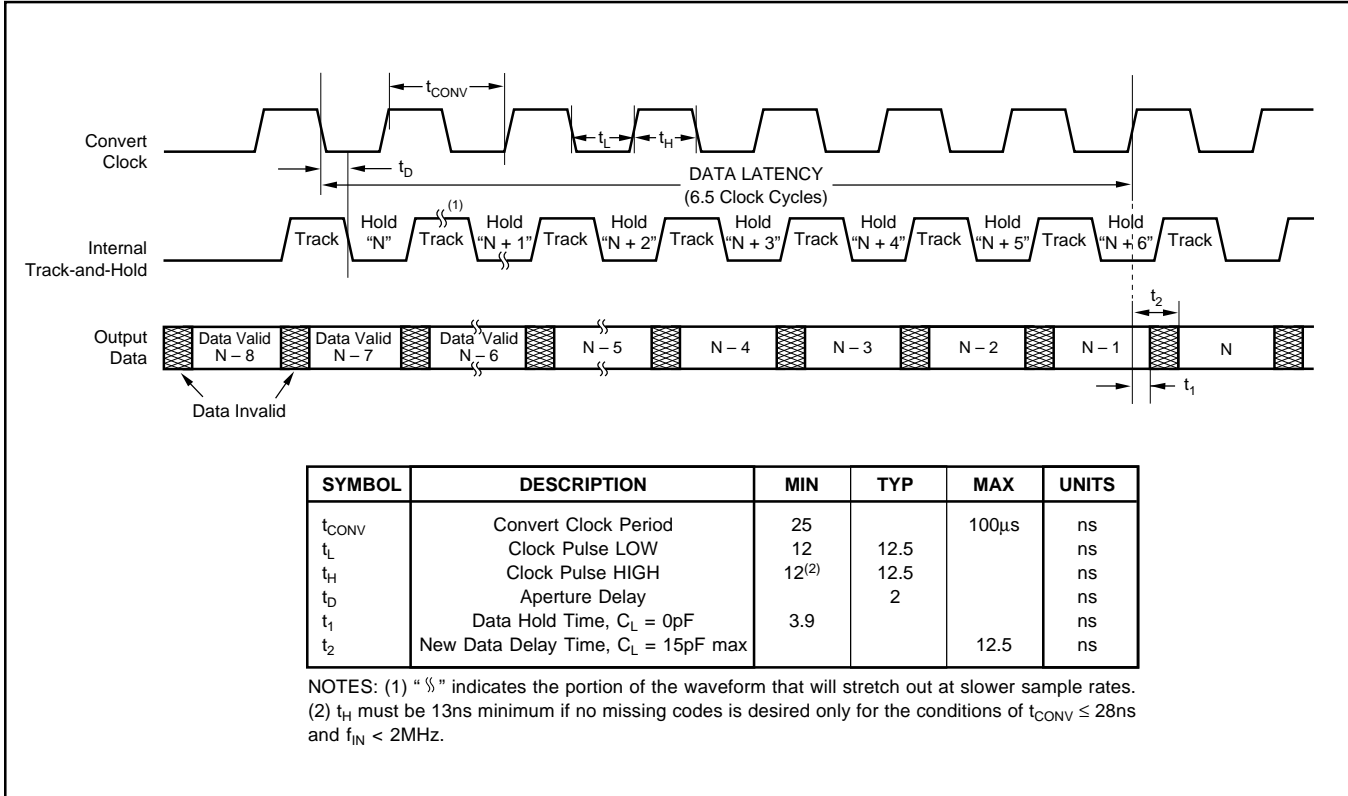

# TYPICAL CHARACTERISTICS

At  $T_A = +25^\circ\text{C}$ ,  $V_S = +5\text{V}$ , Sampling Rate = 40MHz, and with a 50% duty cycle clock having a 2ns rise-and-fall time, unless otherwise noted.

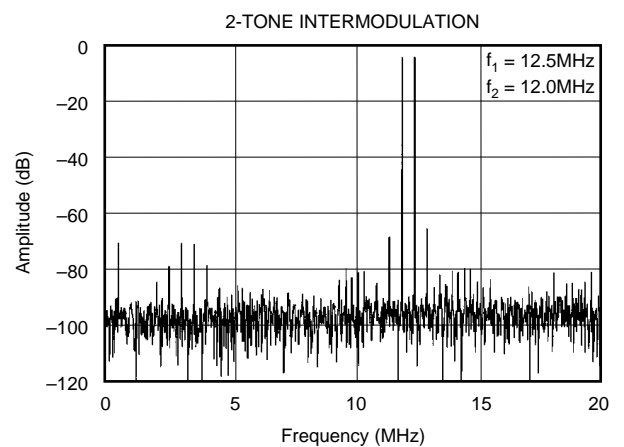
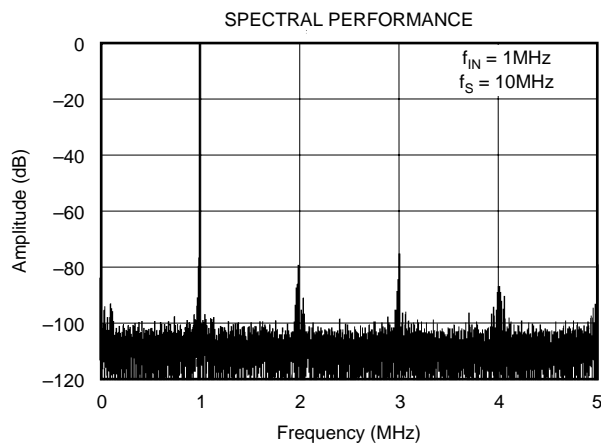
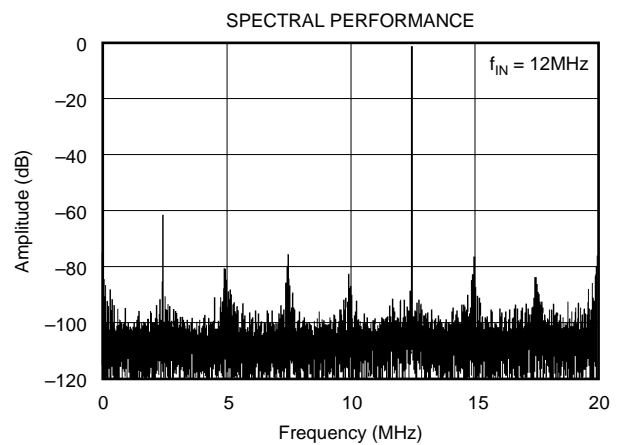
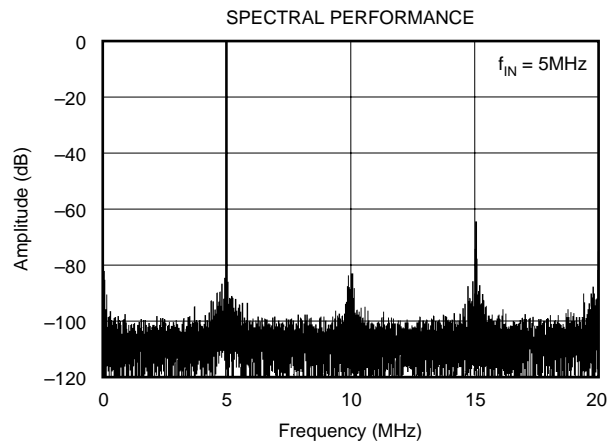
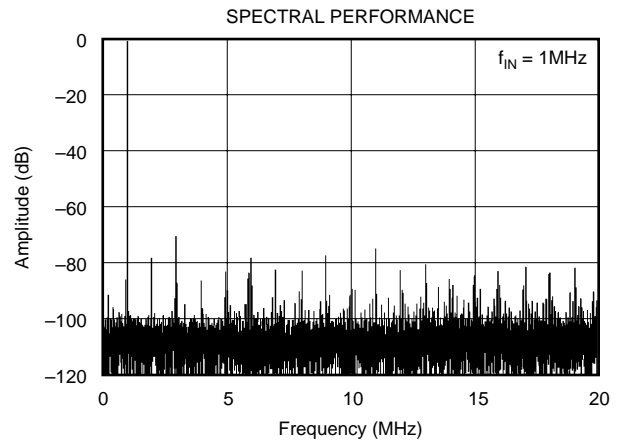
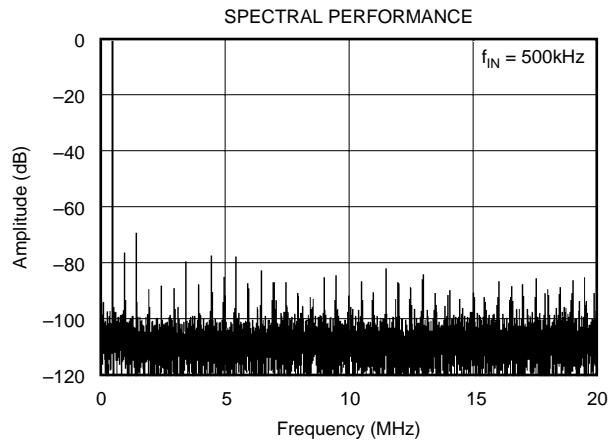

# TYPICAL CHARACTERISTICS (Cont.)

At  $T_A = +25^\circ\text{C}$ ,  $V_S = +5\text{V}$ , Sampling Rate = 40MHz, and with a 50% duty cycle clock having a 2ns rise-and-fall time, unless otherwise noted.

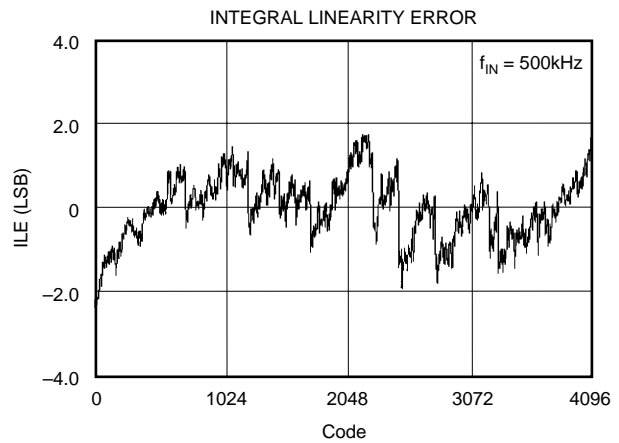
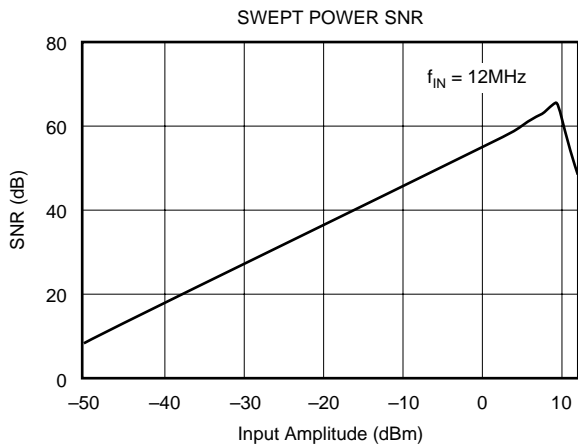
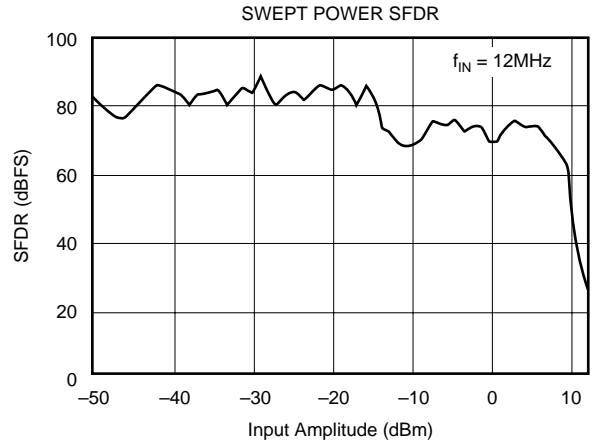
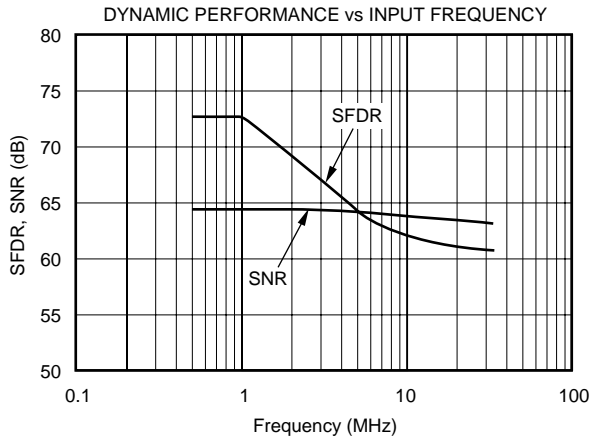
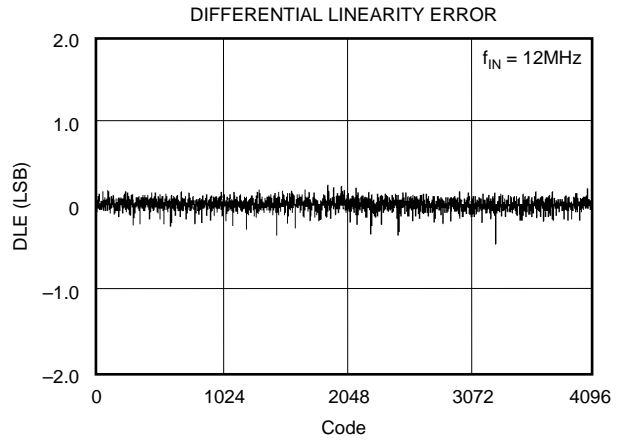
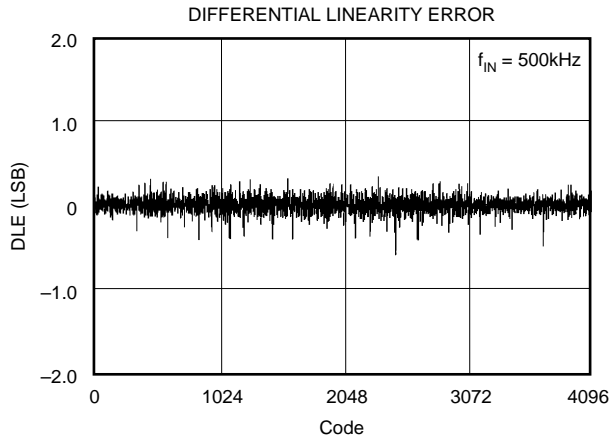

# TYPICAL CHARACTERISTICS (Cont.)

At  $T_A = +25^\circ\text{C}$ ,  $V_S = +5\text{V}$ , Sampling Rate = 40MHz, and with a 50% duty cycle clock having a 2ns rise-and-fall time, unless otherwise noted.

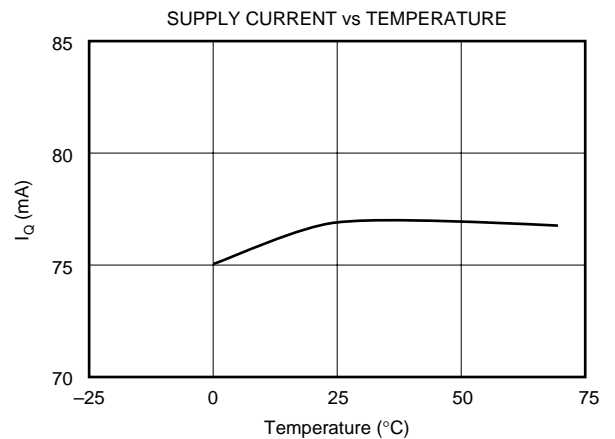
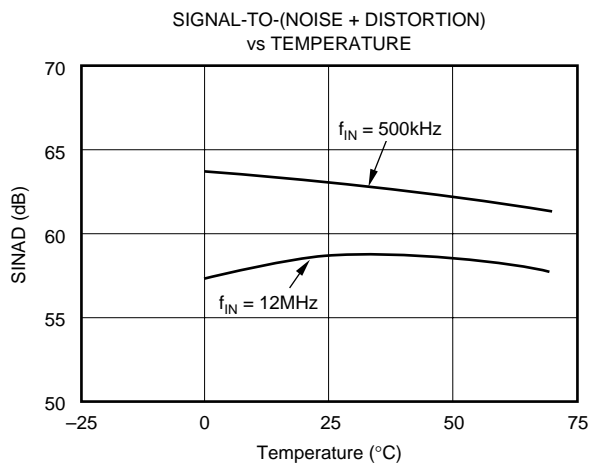
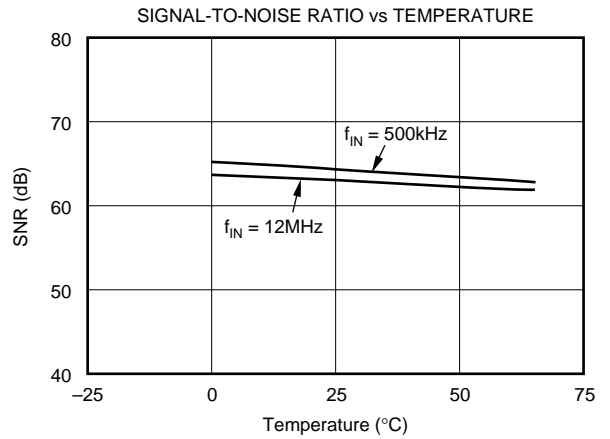
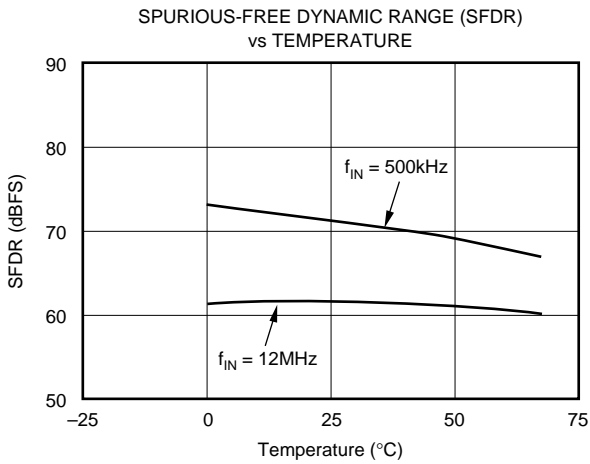
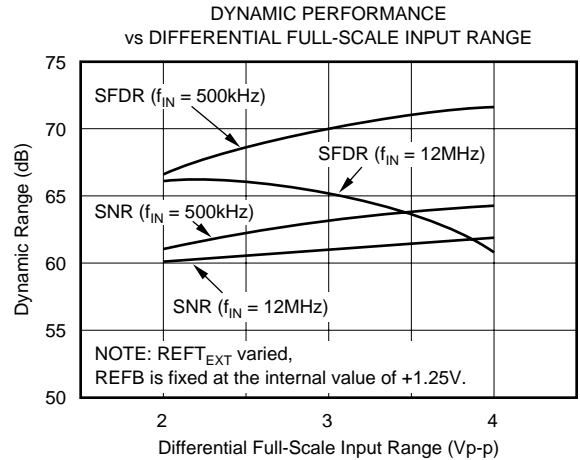
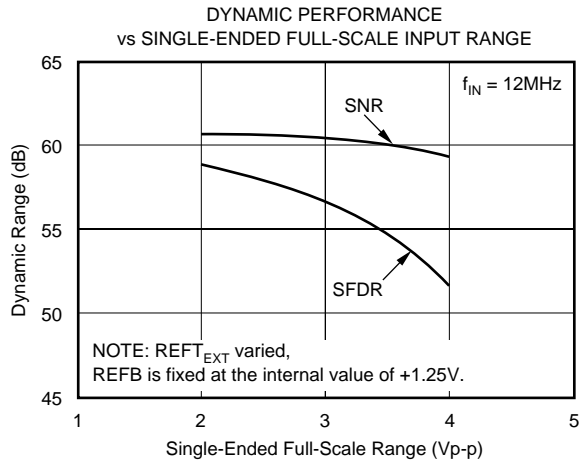

# TYPICAL CHARACTERISTICS (Cont.)

At  $T_A = +25^\circ\text{C}$ ,  $V_S = +5\text{V}$ , Sampling Rate = 40MHz, and with a 50% duty cycle clock having a 2ns rise-and-fall time, unless otherwise noted.

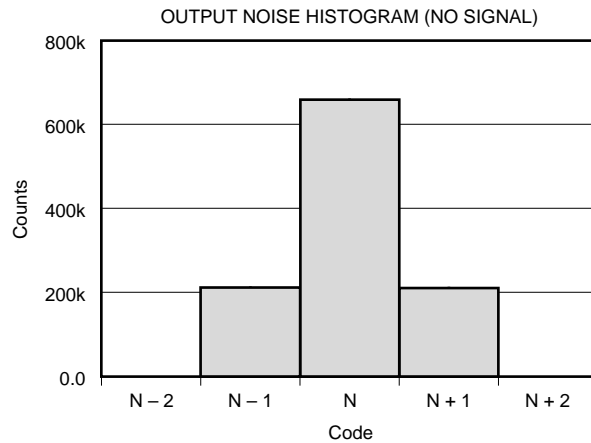
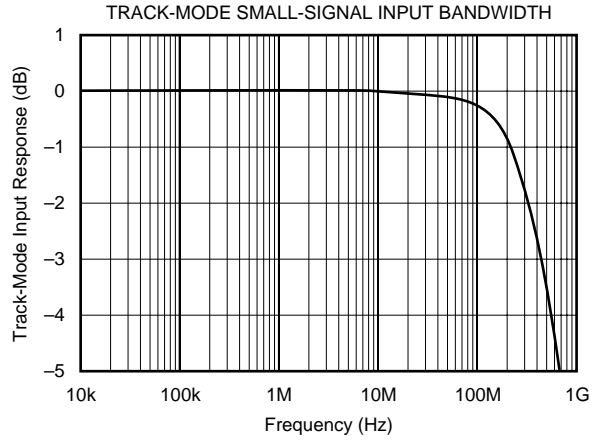
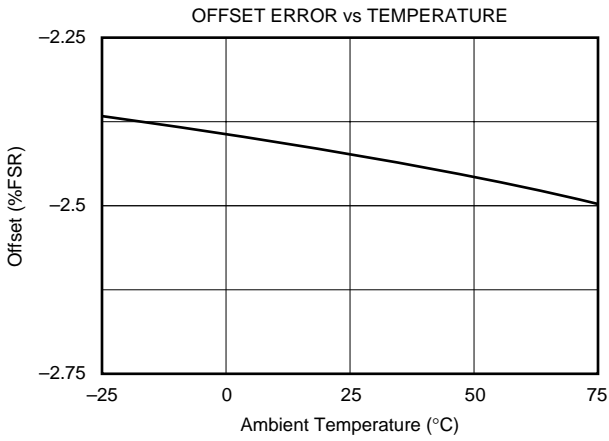
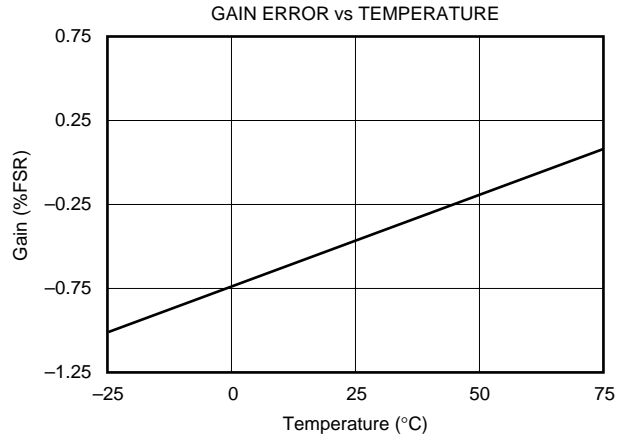
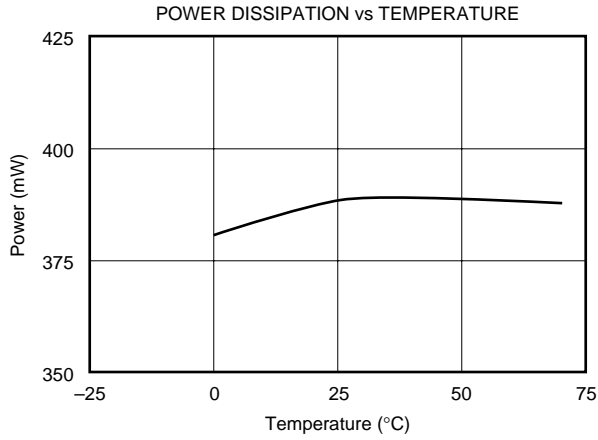

# THEORY OF OPERATION

The ADS800 is a high-speed, sampling A/D converter with pipelining. It uses a fully differential architecture and digital error correction to ensure 12-bit resolution. The differential track-and-hold circuit is shown in Figure 1. The switches are controlled by an internal clock which has a non-overlapping 2-phase signal,  $\phi_1$  and  $\phi_2$ . At the sampling time, the input signal is sampled on the bottom plates of the input capacitors. In the next clock phase,  $\phi_2$ , the bottom plates of the input capacitors are connected together and the feedback capacitors are switched to the op amp output. At this time, the charge redistributes between  $C_1$  and  $C_H$ , completing one track-and-hold cycle. The differential output is a held DC representation of the analog input at the sample time. The track-and-hold circuit can also convert a single-ended input signal into a fully differential signal for the quantizer.

The pipelined quantizer architecture has 11 stages with each stage containing a 2-bit quantizer and a 2-bit Digital-to-Analog Converter (DAC), as shown in Figure 2. Each 2-bit quantizer stage converts on the edge of the sub-clock, which is twice the frequency of the externally applied clock. The output of each quantizer is fed into its own delay line to time-

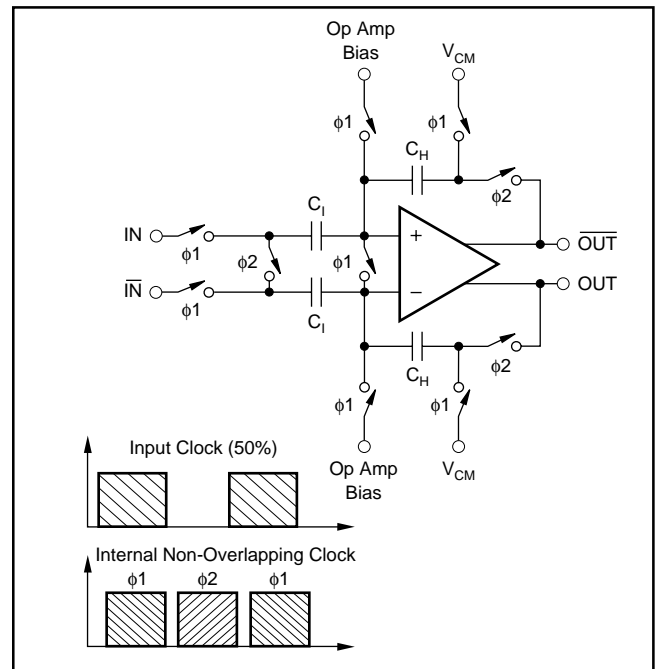

FIGURE 1. Input Track-and-Hold Configuration with Timing Signals.

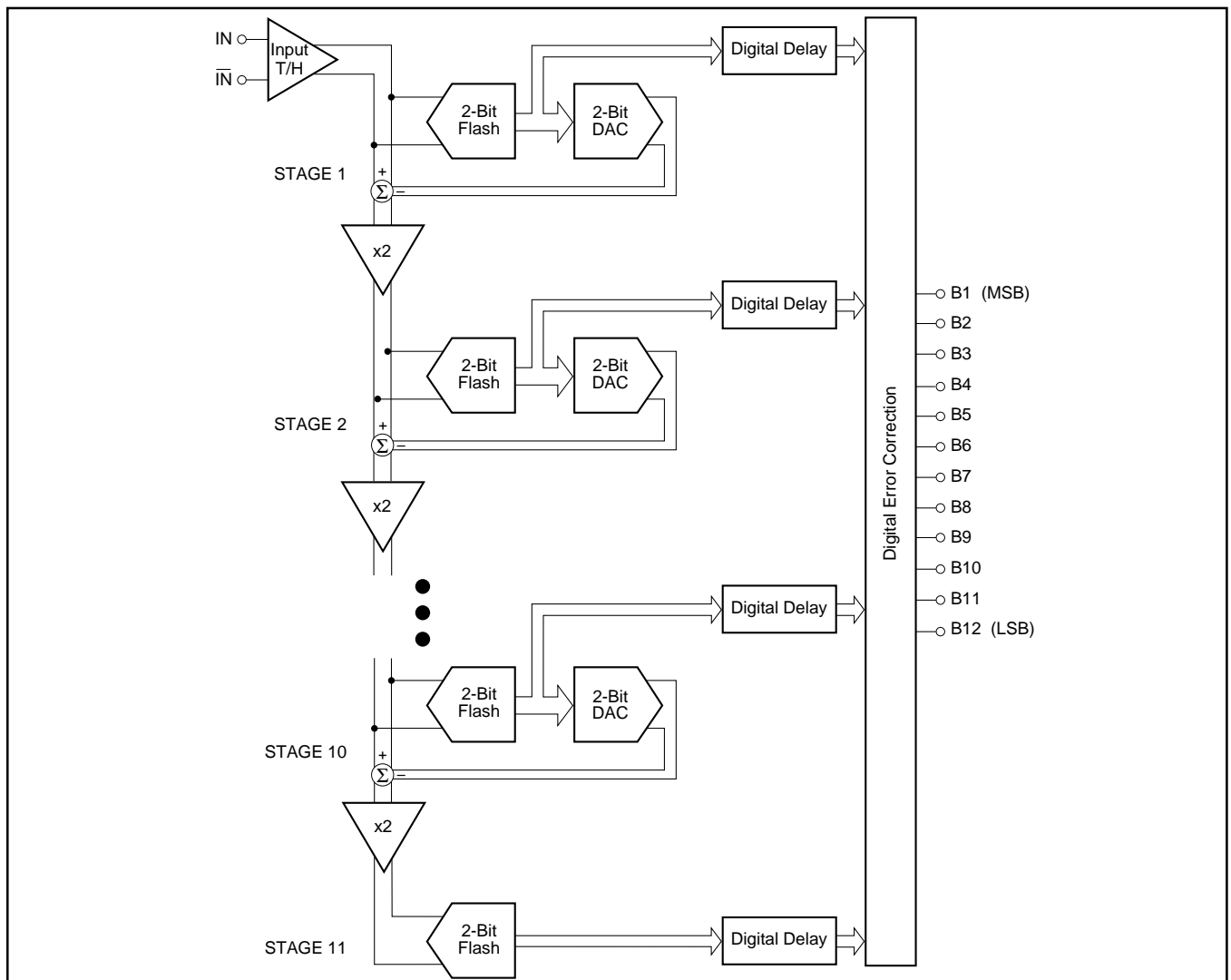

FIGURE 2. Pipeline A/D Converter Architecture.

align it with the data created from the following quantizer stages. This aligned data is fed into a digital error correction circuit which can adjust the output data based on the information found on the redundant bits. This technique gives the ADS800 excellent differential linearity and ensures no missing codes at the 12-bit level.

Since there are two pipeline stages per external clock cycle, there is a 6.5 clock cycle data latency from the start convert signal to the valid output data. The output data is available in Straight Offset Binary (SOB) or Binary Two's Complement (BTC) format.

### THE ANALOG INPUT AND INTERNAL REFERENCE

The analog input of the ADS800 can be configured in various ways and driven with different circuits, depending on the nature of the signal and the level of performance desired. The ADS800 has an internal reference that sets the full-scale input range of the A/D converter. The differential input range has each input centered around the common-mode of +2.25V, with each of the two inputs having a full-scale range of +1.25V to +3.25V. Since each input is 2Vp-p and 180° out-of-phase with the other, a 4V differential input signal to the quantizer results. As shown in Figure 3, the positive full-scale reference (REFT) and the negative full-scale (REFB) are brought out for external bypassing. In addition, the common-mode voltage (CM) may be used as a reference to provide the appropriate offset for the driving circuitry. However, care must be taken not to appreciably load this reference node. For more information regarding external references, single-ended input, and ADS800 drive circuits, refer to the applications section.

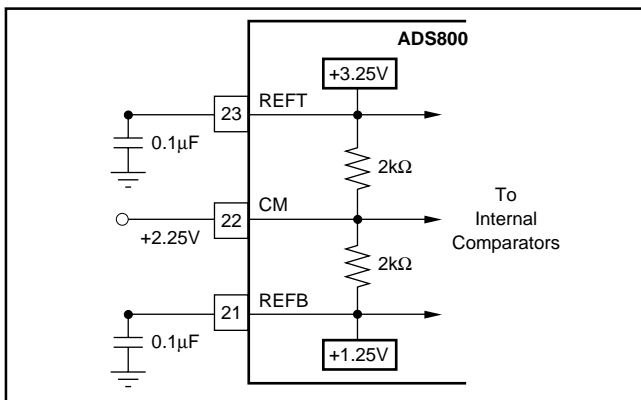

FIGURE 3. Internal Reference Structure.

### CLOCK REQUIREMENTS

The CLK pin accepts a CMOS level clock input. Both the rising and falling edges of the externally applied clock control the various interstage conversions in the pipeline. Therefore, the clock signal's jitter, rise-and-fall times, and duty cycle can affect conversion performance.

- Low clock **jitter** is critical to SNR performance in frequency-domain signal environments.
- Clock **rise-and-fall times** should be as short as possible (< 2ns for best performance).

- For most applications, the clock duty should be set to 50%. However, for applications requiring no missing codes, a slight skew in the duty cycle will improve DNL performance for conversion rates > 35MHz and input frequencies < 2MHz (see Timing Diagram) in the SO package. For the best performance in the SSOP package, the clock should be skewed under all input frequencies with conversion rates > 35MHz. A possible method for skewing the 50% duty cycle source is shown in Figure 4.

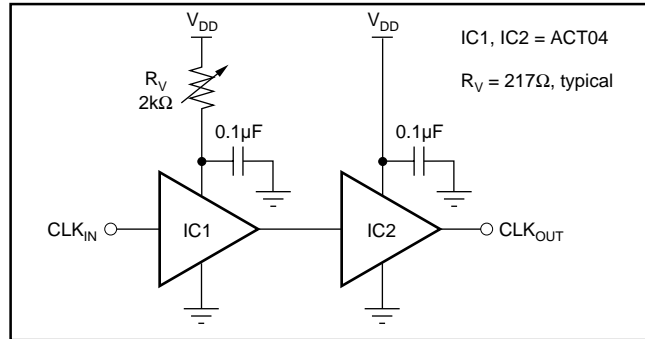

FIGURE 4. Clock Skew Circuit.

### DIGITAL OUTPUT DATA

The 12-bit output data is provided at CMOS logic levels. The standard output coding is Straight Offset Binary (SOB) where a full-scale input signal corresponds to all "1's" at the output, as shown in Table 1. This condition is met with pin 19 "LO" or Floating due to an internal pull-down resistor. By applying a logic "HI" voltage to this pin, a Binary Two's Complement (BTC) output will be provided where the most significant bit is inverted. The digital outputs of the ADS800 can be set to a high-impedance state by driving  $\overline{OE}$  (pin 18) with a logic "HI". Normal operation is achieved with pin 18 "LO" or Floating due to internal pull-down resistors. This function is provided for testability purposes and is not meant to drive digital buses directly or be dynamically changed during the conversion process.

DIFFERENTIAL INPUT <sup>(1)</sup>	OUTPUT CODE	
	SOB PIN 19 FLOATING or LO	BTC PIN 19 HI
+FS (IN = +3.25V, $\overline{IN}$ = +1.25V)	111111111111	011111111111
+FS - 1LSB	111111111111	011111111111
+FS - 2LSB	111111111110	011111111110
+3/4 Full-Scale	111000000000	011000000000
+1/2 Full-Scale	110000000000	010000000000
+1/4 Full-Scale	101000000000	001000000000
+1LSB	100000000001	000000000001
Bipolar Zero (IN = $\overline{IN}$ = +2.25V)	100000000000	000000000000
-1LSB	011111111111	111111111111
-1/4 Full-Scale	011000000000	111000000000
-1/2 Full-Scale	010000000000	110000000000
-3/4 Full-Scale	001000000000	101000000000
-FS + 1LSB	000000000001	100000000001
-FS (IN = +1.25V, $\overline{IN}$ = +3.25V)	000000000000	100000000000

NOTE: (1) In the single-ended input mode, +FS = +4.25V and -FS = +0.25V.

TABLE I. Coding Table for the ADS800.

# APPLICATIONS

## DRIVING THE ADS800

The ADS800 has a differential input with a common-mode of +2.25V. For AC-coupled applications, the simplest way to create this differential input is to drive the primary winding of a transformer with a single-ended input. A differential output is created on the secondary if the center tap is tied to the common-mode voltage of +2.25V, as per Figure 5. This transformer-coupled input arrangement provides good high-frequency AC performance. It is important to select a transformer that gives low distortion and does not exhibit core saturation at full-scale voltage levels. Since the transformer does not appreciably load the ladder, there is no need to buffer the Common-Mode (CM) output in this instance. In general, it is advisable to keep the current draw from the CM output pin below 0.5μA to avoid nonlinearity in the internal reference ladder. A FET input operational amplifier such as the OPA130 can provide a buffered reference for driving external circuitry. The analog IN and  $\overline{\text{IN}}$  inputs should be bypassed with 22pF capacitors to minimize track-and-hold glitches and to improve high input frequency performance.

Figure 6 illustrates another possible low-cost interface circuit which utilizes resistors and capacitors in place of a transformer. Depending on the signal bandwidth, the component values should be carefully selected in order to maintain the

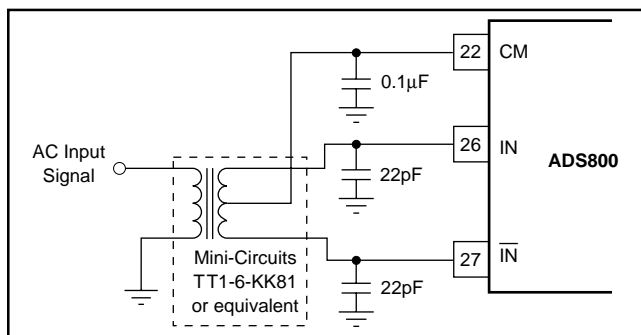

FIGURE 5. AC-Coupled Single-Ended to Differential Drive Circuit Using a Transformer.

product performance. The input capacitors,  $C_{\text{IN}}$ , and the input resistors,  $R_{\text{IN}}$ , create a high-pass filter with the lower corner frequency at  $f_c = 1/(2\pi R_{\text{IN}} C_{\text{IN}})$ . The corner frequency can be reduced by either increasing the value of  $R_{\text{IN}}$  or  $C_{\text{IN}}$ . If the circuit operates with a 50Ω or 75Ω impedance level, the resistors are fixed and only the value of the capacitor can be increased. Usually, AC-coupling capacitors are electrolytic or tantalum capacitors with values of 1μF or higher. It should be noted that these large capacitors become inductive with increased input frequency, which could lead to signal amplitude errors or oscillation. To maintain a low AC-coupling impedance throughout the signal band, a small value (e.g. 1μF) ceramic capacitor could be added in parallel with the polarized capacitor.

Capacitors  $C_{\text{SH1}}$  and  $C_{\text{SH2}}$  are used to minimize current glitches resulting from the switching in the input track-and-hold stage and to improve signal-to-noise performance. These capacitors can also be used to establish a low-pass filter and effectively reduce the noise bandwidth. In order to create a real pole, resistors  $R_{\text{SER1}}$  and  $R_{\text{SER2}}$  were added in series with each input. The cutoff frequency of the filter is determined by  $f_c = 1/(2\pi R_{\text{SER}} \cdot (C_{\text{SH}} + C_{\text{ADC}}))$  where  $R_{\text{SER}}$  is the resistor in series with the input,  $C_{\text{SH}}$  is the external capacitor from the input to ground, and  $C_{\text{ADC}}$  is the internal input capacitance of the A/D converter (typically 4pF).

Resistors  $R_1$  and  $R_2$  are used to derive the necessary common-mode voltage from the buffered top and bottom references. The total load of the resistor string should be selected so that the current does not exceed 1mA. Although the circuit in Figure 6 uses two resistors of equal value so that the common-mode voltage is centered between the top and bottom reference (+2.25V), it is not necessary to do so. In all cases the center point,  $V_{\text{CM}}$ , should be bypassed to ground in order to provide a low-impedance AC ground.

If the signal needs to be DC coupled to the input of the ADS800, an operational amplifier input circuit is required. In the differential input mode, any single-ended signal must be modified to create a differential signal. This can be accomplished by

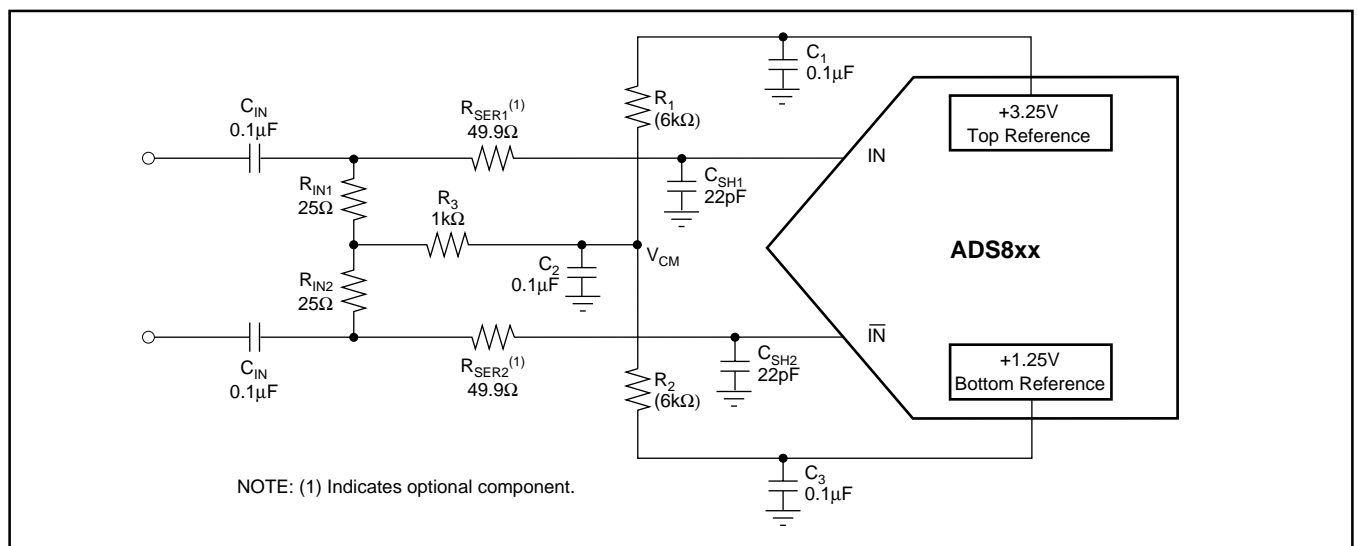

FIGURE 6. AC-Coupled Differential Input Circuit.



set halfway between the two references. This feature can be used to adjust the gain error, improve gain drift, or to change the full-scale input range of the ADS800. Changing the full-scale range to a lower value has the benefit of easing the swing requirements of external input drive amplifiers. The external references can vary as long as the value of the external top reference (REF<sub>T\_EXT</sub>) is less than or equal to +3.4V, the value of the external bottom reference (REF<sub>B\_EXT</sub>) is greater than or equal to +1.1V, and the difference between the external references are greater than or equal to 1.5V.

For the differential configuration, the full-scale input range will be set to the external reference values that are selected. For the single-ended mode, the input range is  $2 \cdot (\text{REF}_{\text{T\_EXT}} - \text{REF}_{\text{B\_EXT}})$ , with the common-mode being centered at  $(\text{REF}_{\text{T\_EXT}} + \text{REF}_{\text{B\_EXT}})/2$ . Refer to the typical characteristics for “Expected Performance vs Full-Scale Input Range”.

The circuit in Figure 10 works completely on a single +5V supply. As a reference element, it uses the micro-power reference REF1004-2.5, which is set to a quiescent current of 0.1mA. Amplifier A<sub>2</sub> is configured as a follower to buffer the +1.25V generated from the resistor divider. To provide the necessary current drive, a pull-down resistor, R<sub>p</sub>, is added.

Amplifier A<sub>1</sub> is configured as an adjustable gain stage, with a range of approximately 1 to 1.32. The pull-up resistor again relieves the op amp from providing the full current drive. The value of the pull-up/down resistors is not critical and can be varied to optimize power consumption. The need for pull-up, pull-down resistors depends only on the drive capability of the selected drive amplifiers and thus can be omitted.

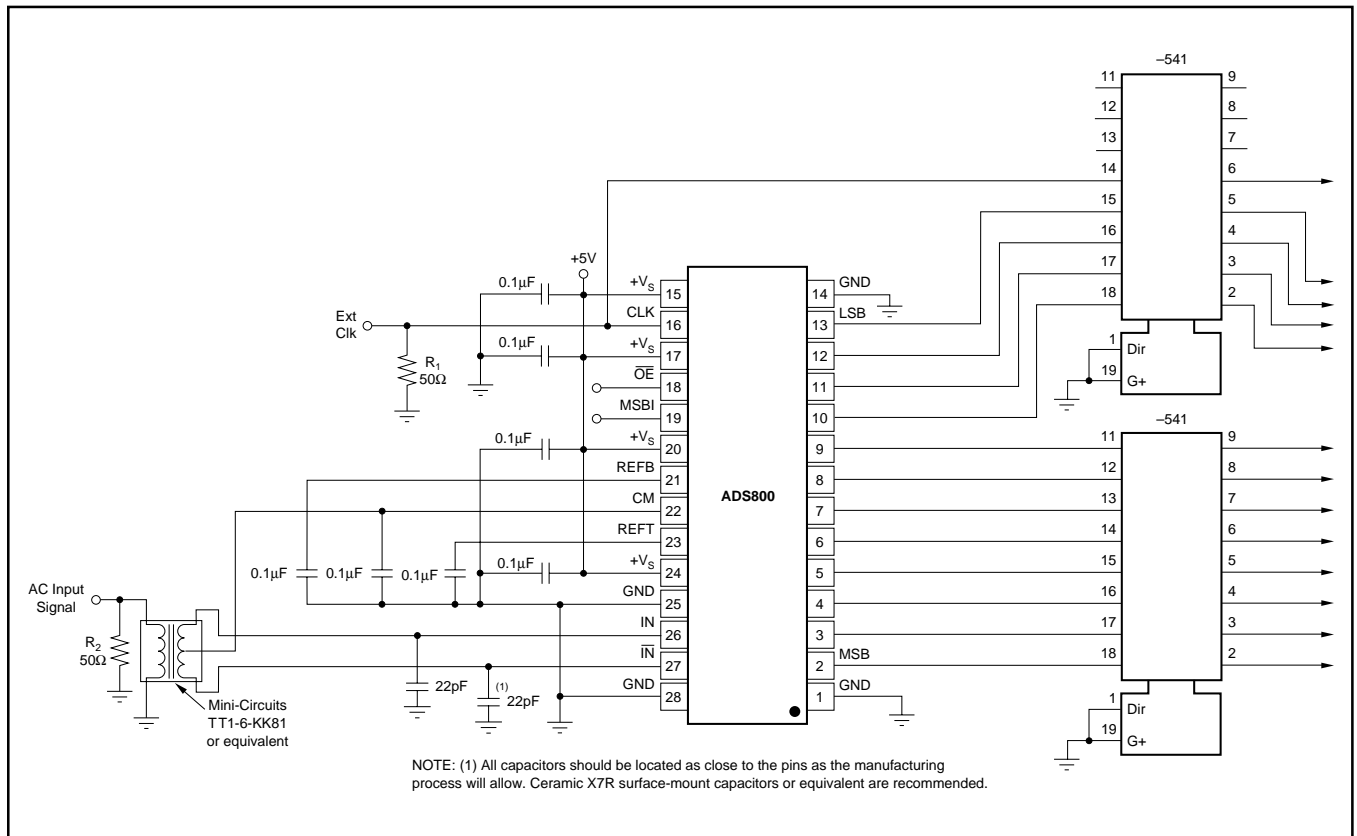

FIGURE 9. ADS800 Interface Schematic with AC-Coupling and External Buffers.

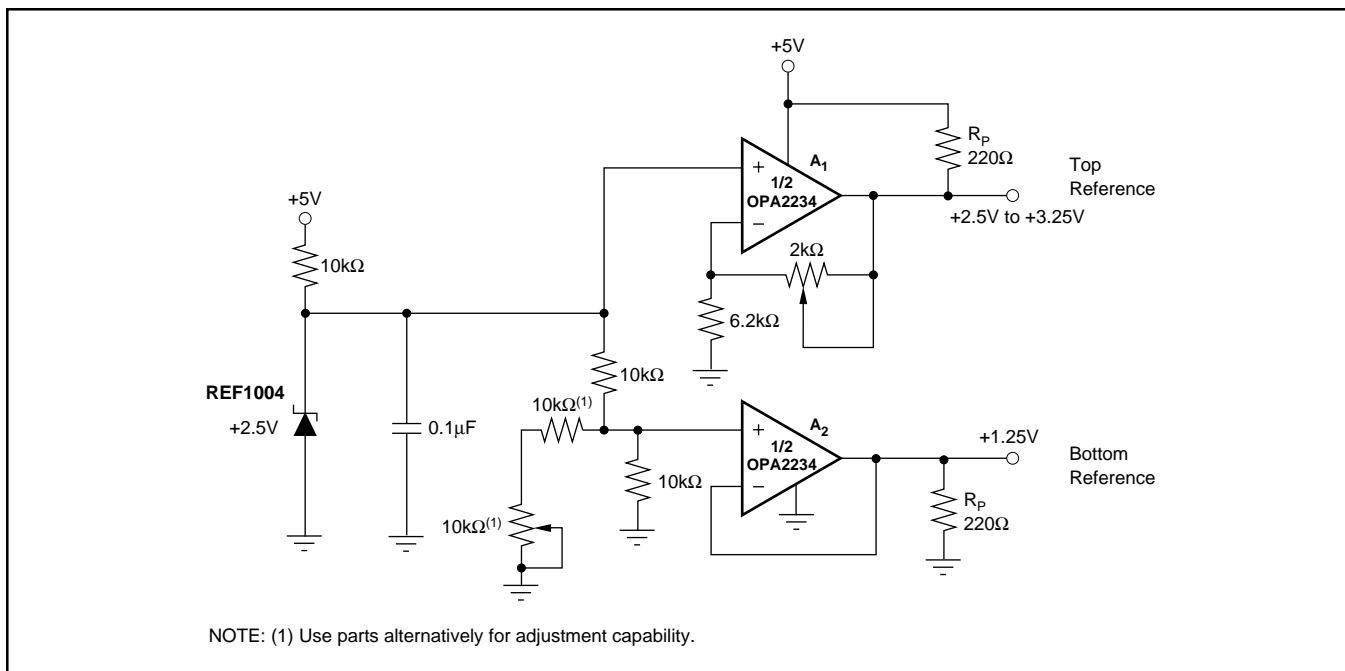

FIGURE 10. Optional External Reference to Set the Full-Scale Range Utilizing a Dual, Single-Supply Op Amp.

### PC BOARD LAYOUT AND BYPASSING

A well-designed, clean PC board layout will assure proper operation and clean spectral response. Proper grounding and bypassing, short lead lengths, and the use of ground planes are particularly important for high-frequency circuits. Multilayer PC boards are recommended for best performance but if carefully designed, a two-sided PC board with large, heavy ground planes can give excellent results. It is recommended that the analog and digital ground pins of the ADS800 be connected directly to the analog ground plane. In our experience, this gives the most consistent results. The A/D converter power-supply commons should be tied together at the analog ground plane. Power supplies should be bypassed with 0.1µF ceramic capacitors as close to the pin as possible.

### DYNAMIC PERFORMANCE TESTING

The ADS800 is a high performance converter and careful attention to test techniques is necessary to achieve accurate results. Highly accurate phase-locked signal sources allow high resolution FFT measurements to be made without using data windowing functions. A low jitter signal generator such as the HP8644A for the test signal, phase-locked with a low jitter

HP8022A pulse generator for the A/D converter clock, gives excellent results. Low-pass filtering (or bandpass filtering) of test signals is absolutely necessary to test the low distortion of the ADS800. Using a signal amplitude slightly lower than full-scale will allow a small amount of “headroom” so that noise or DC offset voltage will not over-range the A/D converter and cause clipping on signal peaks.

### DYNAMIC PERFORMANCE DEFINITIONS

- Signal-to-Noise-and-Distortion Ratio (SINAD):
 
$$10 \log \frac{\text{Sinewave Signal Power}}{\text{Noise} + \text{Harmonic Power (first 15 harmonics)}}$$
- Signal-to-Noise Ratio (SNR):
 
$$10 \log \frac{\text{Sinewave Signal Power}}{\text{Noise Power}}$$
- Intermodulation Distortion (IMD):
 
$$10 \log \frac{\text{Highest IMD Product Power (to 5th - order)}}{\text{Sinewave Signal Power}}$$

IMD is referenced to the larger of the test signals,  $f_1$  or  $f_2$ . Five “bins” either side of peak are used for calculation of fundamental and harmonic power. The “0” frequency bin (DC) is not included in these calculations as it is of little importance in dynamic signal processing applications.

**PACKAGING INFORMATION**

Orderable Device	Status <sup>(1)</sup>	Package Type	Package Drawing	Pins	Package Qty	Eco Plan <sup>(2)</sup>	Lead/ Ball Finish	MSL Peak Temp <sup>(3)</sup>	Samples (Requires Login)
ADS800E	OBSOLETE	SSOP	DB	28		TBD	Call TI	Call TI	
ADS800E/1K	OBSOLETE	SSOP	DB	28		TBD	Call TI	Call TI	
ADS800U	ACTIVE	SOIC	DW	28	20	Green (RoHS & no Sb/Br)	CU NIPDAU	Level-2-260C-1 YEAR	
ADS800U/1K	ACTIVE	SOIC	DW	28	1000	Green (RoHS & no Sb/Br)	CU NIPDAU	Level-2-260C-1 YEAR	
ADS800U/1KG4	ACTIVE	SOIC	DW	28	1000	Green (RoHS & no Sb/Br)	CU NIPDAU	Level-2-260C-1 YEAR	
ADS800UG4	ACTIVE	SOIC	DW	28	20	Green (RoHS & no Sb/Br)	CU NIPDAU	Level-2-260C-1 YEAR	

<sup>(1)</sup> The marketing status values are defined as follows:

**ACTIVE:** Product device recommended for new designs.

**LIFEBUY:** TI has announced that the device will be discontinued, and a lifetime-buy period is in effect.

**NRND:** Not recommended for new designs. Device is in production to support existing customers, but TI does not recommend using this part in a new design.

**PREVIEW:** Device has been announced but is not in production. Samples may or may not be available.

**OBSOLETE:** TI has discontinued the production of the device.

<sup>(2)</sup> Eco Plan - The planned eco-friendly classification: Pb-Free (RoHS), Pb-Free (RoHS Exempt), or Green (RoHS & no Sb/Br) - please check <http://www.ti.com/productcontent> for the latest availability information and additional product content details.

**TBD:** The Pb-Free/Green conversion plan has not been defined.

**Pb-Free (RoHS):** TI's terms "Lead-Free" or "Pb-Free" mean semiconductor products that are compatible with the current RoHS requirements for all 6 substances, including the requirement that lead not exceed 0.1% by weight in homogeneous materials. Where designed to be soldered at high temperatures, TI Pb-Free products are suitable for use in specified lead-free processes.

**Pb-Free (RoHS Exempt):** This component has a RoHS exemption for either 1) lead-based flip-chip solder bumps used between the die and package, or 2) lead-based die adhesive used between the die and leadframe. The component is otherwise considered Pb-Free (RoHS compatible) as defined above.

**Green (RoHS & no Sb/Br):** TI defines "Green" to mean Pb-Free (RoHS compatible), and free of Bromine (Br) and Antimony (Sb) based flame retardants (Br or Sb do not exceed 0.1% by weight in homogeneous material)

<sup>(3)</sup> MSL, Peak Temp. -- The Moisture Sensitivity Level rating according to the JEDEC industry standard classifications, and peak solder temperature.

**Important Information and Disclaimer:** The information provided on this page represents TI's knowledge and belief as of the date that it is provided. TI bases its knowledge and belief on information provided by third parties, and makes no representation or warranty as to the accuracy of such information. Efforts are underway to better integrate information from third parties. TI has taken and continues to take reasonable steps to provide representative and accurate information but may not have conducted destructive testing or chemical analysis on incoming materials and chemicals. TI and TI suppliers consider certain information to be proprietary, and thus CAS numbers and other limited information may not be available for release.

In no event shall TI's liability arising out of such information exceed the total purchase price of the TI part(s) at issue in this document sold by TI to Customer on an annual basis.



**TAPE AND REEL INFORMATION**
**REEL DIMENSIONS**

**TAPE DIMENSIONS**

A0	Dimension designed to accommodate the component width
B0	Dimension designed to accommodate the component length
K0	Dimension designed to accommodate the component thickness
W	Overall width of the carrier tape
P1	Pitch between successive cavity centers

**TAPE AND REEL INFORMATION**

\*All dimensions are nominal

Device	Package Type	Package Drawing	Pins	SPQ	Reel Diameter (mm)	Reel Width W1 (mm)	A0 (mm)	B0 (mm)	K0 (mm)	P1 (mm)	W (mm)	Pin1 Quadrant
ADS800U/1K	SOIC	DW	28	1000	330.0	32.4	11.35	18.67	3.1	16.0	32.0	Q1

TAPE AND REEL BOX DIMENSIONS



\*All dimensions are nominal

Device	Package Type	Package Drawing	Pins	SPQ	Length (mm)	Width (mm)	Height (mm)
ADS800U/1K	SOIC	DW	28	1000	367.0	367.0	55.0



DW (R-PDSO-G28)

PLASTIC SMALL OUTLINE

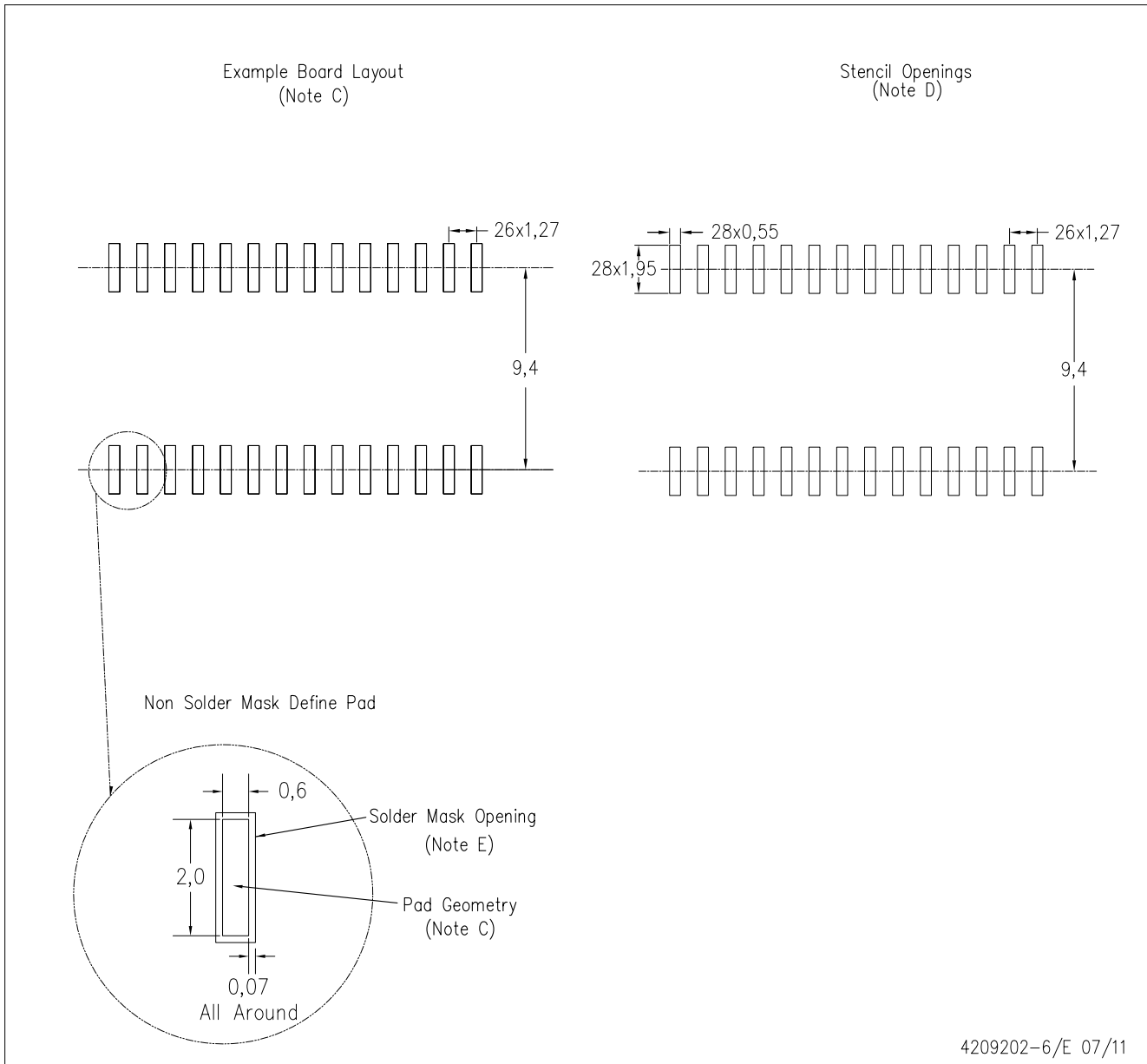

4209202-6/E 07/11

- NOTES:
- A. All linear dimensions are in millimeters.
  - B. This drawing is subject to change without notice.
  - C. Refer to IPC7351 for alternate board design.
  - D. Laser cutting apertures with trapezoidal walls and also rounding corners will offer better paste release. Customers should contact their board assembly site for stencil design recommendations. Refer to IPC-7525
  - E. Customers should contact their board fabrication site for solder mask tolerances between and around signal pads.

DB (R-PDSO-G\*\*)

PLASTIC SMALL-OUTLINE

28 PINS SHOWN



- NOTES: A. All linear dimensions are in millimeters.  
 B. This drawing is subject to change without notice.  
 C. Body dimensions do not include mold flash or protrusion not to exceed 0,15.  
 D. Falls within JEDEC MO-150

## IMPORTANT NOTICE

Texas Instruments Incorporated and its subsidiaries (TI) reserve the right to make corrections, enhancements, improvements and other changes to its semiconductor products and services per JESD46C and to discontinue any product or service per JESD48B. Buyers should obtain the latest relevant information before placing orders and should verify that such information is current and complete. All semiconductor products (also referred to herein as "components") are sold subject to TI's terms and conditions of sale supplied at the time of order acknowledgment.

TI warrants performance of its components to the specifications applicable at the time of sale, in accordance with the warranty in TI's terms and conditions of sale of semiconductor products. Testing and other quality control techniques are used to the extent TI deems necessary to support this warranty. Except where mandated by applicable law, testing of all parameters of each component is not necessarily performed.

TI assumes no liability for applications assistance or the design of Buyers' products. Buyers are responsible for their products and applications using TI components. To minimize the risks associated with Buyers' products and applications, Buyers should provide adequate design and operating safeguards.

TI does not warrant or represent that any license, either express or implied, is granted under any patent right, copyright, mask work right, or other intellectual property right relating to any combination, machine, or process in which TI components or services are used. Information published by TI regarding third-party products or services does not constitute a license to use such products or services or a warranty or endorsement thereof. Use of such information may require a license from a third party under the patents or other intellectual property of the third party, or a license from TI under the patents or other intellectual property of TI.

Reproduction of significant portions of TI information in TI data books or data sheets is permissible only if reproduction is without alteration and is accompanied by all associated warranties, conditions, limitations, and notices. TI is not responsible or liable for such altered documentation. Information of third parties may be subject to additional restrictions.

Resale of TI components or services with statements different from or beyond the parameters stated by TI for that component or service voids all express and any implied warranties for the associated TI component or service and is an unfair and deceptive business practice. TI is not responsible or liable for any such statements.

Buyer acknowledges and agrees that it is solely responsible for compliance with all legal, regulatory and safety-related requirements concerning its products, and any use of TI components in its applications, notwithstanding any applications-related information or support that may be provided by TI. Buyer represents and agrees that it has all the necessary expertise to create and implement safeguards which anticipate dangerous consequences of failures, monitor failures and their consequences, lessen the likelihood of failures that might cause harm and take appropriate remedial actions. Buyer will fully indemnify TI and its representatives against any damages arising out of the use of any TI components in safety-critical applications.

In some cases, TI components may be promoted specifically to facilitate safety-related applications. With such components, TI's goal is to help enable customers to design and create their own end-product solutions that meet applicable functional safety standards and requirements. Nonetheless, such components are subject to these terms.

No TI components are authorized for use in FDA Class III (or similar life-critical medical equipment) unless authorized officers of the parties have executed a special agreement specifically governing such use.

Only those TI components which TI has specifically designated as military grade or "enhanced plastic" are designed and intended for use in military/aerospace applications or environments. Buyer acknowledges and agrees that any military or aerospace use of TI components which have **not** been so designated is solely at the Buyer's risk, and that Buyer is solely responsible for compliance with all legal and regulatory requirements in connection with such use.

TI has specifically designated certain components which meet ISO/TS16949 requirements, mainly for automotive use. Components which have not been so designated are neither designed nor intended for automotive use; and TI will not be responsible for any failure of such components to meet such requirements.

### Products

Audio	<a href="http://www.ti.com/audio">www.ti.com/audio</a>
Amplifiers	<a href="http://amplifier.ti.com">amplifier.ti.com</a>
Data Converters	<a href="http://dataconverter.ti.com">dataconverter.ti.com</a>
DLP® Products	<a href="http://www.dlp.com">www.dlp.com</a>
DSP	<a href="http://dsp.ti.com">dsp.ti.com</a>
Clocks and Timers	<a href="http://www.ti.com/clocks">www.ti.com/clocks</a>
Interface	<a href="http://interface.ti.com">interface.ti.com</a>
Logic	<a href="http://logic.ti.com">logic.ti.com</a>
Power Mgmt	<a href="http://power.ti.com">power.ti.com</a>
Microcontrollers	<a href="http://microcontroller.ti.com">microcontroller.ti.com</a>
RFID	<a href="http://www.ti-rfid.com">www.ti-rfid.com</a>
OMAP Mobile Processors	<a href="http://www.ti.com/omap">www.ti.com/omap</a>
Wireless Connectivity	<a href="http://www.ti.com/wirelessconnectivity">www.ti.com/wirelessconnectivity</a>

### Applications

Automotive and Transportation	<a href="http://www.ti.com/automotive">www.ti.com/automotive</a>
Communications and Telecom	<a href="http://www.ti.com/communications">www.ti.com/communications</a>
Computers and Peripherals	<a href="http://www.ti.com/computers">www.ti.com/computers</a>
Consumer Electronics	<a href="http://www.ti.com/consumer-apps">www.ti.com/consumer-apps</a>
Energy and Lighting	<a href="http://www.ti.com/energy">www.ti.com/energy</a>
Industrial	<a href="http://www.ti.com/industrial">www.ti.com/industrial</a>
Medical	<a href="http://www.ti.com/medical">www.ti.com/medical</a>
Security	<a href="http://www.ti.com/security">www.ti.com/security</a>
Space, Avionics and Defense	<a href="http://www.ti.com/space-avionics-defense">www.ti.com/space-avionics-defense</a>
Video and Imaging	<a href="http://www.ti.com/video">www.ti.com/video</a>

**TI E2E Community** [e2e.ti.com](http://e2e.ti.com)