



16-BIT, 600-kHz, PSEUDO-DIFFERENTIAL INPUT, MICROPOWER SAMPLING ANALOG-TO-DIGITAL CONVERTER WITH SERIAL INTERFACE AND REFERENCE

FEATURES

- 600-kHz Sample Rate
- ± 0.5 LSB Typ, ± 1.25 LSB Max INL
- ± 0.4 LSB Typ, ± 0.75 LSB Max DNL
- 16-Bit NMC
- SINAD 89.5 dB, SFDR 119 dB at $f_i = 1$ kHz
- High-Speed Serial Interface up to 40 MHz
- Onboard Reference Buffer
- Onboard 4.096-V Reference
- Pseudo-Differential Input, 0 V to 4.2 V
- Onboard Conversion Clock
- Selectable Output Format, 2's Complement or Straight Binary
- Zero Latency
- Wide Digital Supply
- Low Power:
 - 110 mW at 600 kHz
 - 15 mW During Nap Mode
 - 10 μ W During Power Down
- 28-Pin 6 x 6 QFN Package

- Pin compatible With 18-Bit ADS8380

APPLICATIONS

- Medical Instruments
- Optical Networking
- Transducer Interface
- High Accuracy Data Acquisition Systems
- Magnetometers

DESCRIPTION

The ADS8370 is a high performance 16-bit, 600-kHz A/D converter with single-ended (pseudo-differential) input. The device includes an 16-bit capacitor-based SAR A/D converter with inherent sample and hold. The ADS8370 offers a high-speed CMOS serial interface with clock speeds up to 40 MHz.

The ADS8370 is available in a 28 lead 6 x 6 QFN package and is characterized over the industrial -40°C to 85°C temperature range.

High Speed SAR Converter Family

| Type/Speed | 500 kHz | ~ 600 kHz | 750 kHz | 1 MHz | 1.25 MHz | 2 MHz | 3 MHz | 4 MHz |
|-----------------------------------|---------|-------------|---------|---------|-------------|---------|---------|---------|
| 18-Bit Pseudo-Diff | ADS8383 | ADS8381 | | | | | | |
| | | ADS8380 (S) | | | | | | |
| 18-Bit Pseudo-Bipolar, Fully Diff | | ADS8382 (S) | | | | | | |
| 16-Bit Pseudo-Diff | | ADS8370 (S) | ADS8371 | | ADS8401/05 | ADS8411 | | |
| 16-Bit Pseudo-Bipolar, Fully Diff | | ADS8372 (S) | | | ADS8402/06 | ADS8412 | | |
| 14-Bit Pseudo-Diff | | | | | ADS7890 (S) | | ADS7891 | |
| 12-Bit Pseudo-Diff | | | | ADS7886 | | | | ADS7881 |

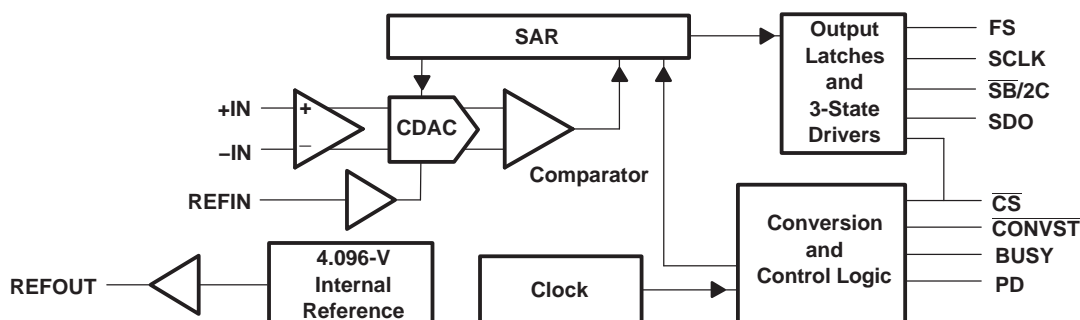

Please be aware that an important notice concerning availability, standard warranty, and use in critical applications of Texas Instruments semiconductor products and disclaimers thereto appears at the end of this data sheet.



These devices have limited built-in ESD protection. The leads should be shorted together or the device placed in conductive foam during storage or handling to prevent electrostatic damage to the MOS gates.

ORDERING INFORMATION⁽¹⁾

| MODEL | MAXIMUM INTEGRAL LINEARITY (LSB) | MAXIMUM DIFFERENTIAL LINEARITY (LSB) | NO MISSING CODES RESOLUTION (BIT) | PACKAGE TYPE | PACKAGE DESIGNATOR | TEMPERATURE RANGE | ORDERING INFORMATION | TRANSPORT MEDIA QUANTITY |
|-----------|----------------------------------|--------------------------------------|-----------------------------------|-------------------|--------------------|-------------------|----------------------|--------------------------|
| ADS8370I | ±2 | -1/1.5 | 16 | 28 Pin 6x6 QFN | RHP | -40°C to 85°C | ADS8370IRHPT | Small Tape and reel 250 |
| | | | | | | | ADS8370IRHPR | Tape and reel 2500 |
| ADS8370IB | ±1.25 | ±0.75 | 16 | 28 Pin 6x6 QFN | RHP | -40°C to 85°C | ADS8370IBRHPT | Small Tape and reel 250 |
| | | | | | | | ADS8370IBRHPR | Tape and reel 2500 |

(1) For the most current package and ordering information, see the Package Option Addendum at the end of this document, or see the TI website at www.ti.com.

ABSOLUTE MAXIMUM RATINGS

over operating free-air temperature range unless otherwise noted⁽¹⁾

| | | UNIT |
|--|-----------------------------------|--|
| Voltage | +IN to AGND | -0.3 V to +VA + 0.3 V |
| | -IN to AGND | -0.3 V to +VA + 0.3 V |
| | +VA to AGND | -0.3 V to 6 V |
| | +VBD to BDGND | -0.3 V to 6 V |
| Digital input voltage to BDGND | | -0.3 V to +VBD + 0.3 V |
| Digital input voltage to +VA | | +0.3 V |
| Operating free-air temperature range, T _A | | -40°C to 85°C |
| Storage temperature range, T _{stg} | | -65°C to 150°C |
| Junction temperature (T _J max) | | 150°C |
| QFN package | Power dissipation | (T _J max - T _A)/θ _{JA} |
| | θ _{JA} thermal impedance | 86°C/W |
| Lead temperature, soldering | Vapor phase (60 sec) | 215°C |
| | Infrared (15 sec) | 220°C |

(1) Stresses beyond those listed under "absolute maximum ratings" may cause permanent damage to the device. These are stress ratings only, and functional operation of the device at these or any other conditions beyond those indicated under "recommended operating conditions" is not implied. Exposure to absolute-maximum-rated conditions for extended periods may affect device reliability.

SPECIFICATIONS

At -40°C to 85°C , $+V_A = +5\text{ V}$, $+V_{BD} = +5\text{ V}$ or $+V_{BD} = +2.7\text{ V}$, using internal or external reference, $f_{\text{SAMPLE}} = 600\text{ kHz}$, unless otherwise noted. (All performance parameters are valid only after device has properly resumed from power down, see Table 2.)

| PARAMETER | TEST CONDITIONS | ADS8370IB | | | ADS8370I | | | UNIT |
|---|--|-----------|------------|------------------------|----------|------------|------------------------|-------------------------|
| | | MIN | TYP | MAX | MIN | TYP | MAX | |
| ANALOG INPUT | | | | | | | | |
| Full-scale input voltage ⁽¹⁾ | +IN – (–IN) | 0 | | V_{ref} | 0 | | V_{ref} | V |
| Absolute input voltage | +IN | –0.2 | | $V_{\text{ref}} + 0.2$ | –0.2 | | $V_{\text{ref}} + 0.2$ | V |
| | –IN | –0.2 | | 0.2 | –0.2 | | 0.2 | |
| Sampling capacitance (measured from $\pm\text{IN}$ to AGND) | | | 40 | | | 40 | | pF |
| Input leakage current | | | 1 | | | 1 | | nA |
| SYSTEM PERFORMANCE | | | | | | | | |
| Resolution | | | 16 | | | 16 | | Bits |
| No missing codes | | | 16 | | | 16 | | Bits |
| INL Integral linearity ⁽²⁾⁽³⁾⁽⁴⁾ | Quiet zones observed | –1.25 | ± 0.5 | 1.25 | –2 | | 2 | LSB (16 bit) |
| | Quiet zones not observed | | ± 0.8 | | | | | |
| DNL Differential linearity ⁽³⁾ | Quiet zones observed | –0.75 | ± 0.4 | 0.75 | –1 | | 1.5 | LSB (16 bit) |
| | Quiet zones not observed | | ± 0.75 | | | | | |
| E_O Offset error ⁽³⁾ | | –0.75 | ± 0.4 | 0.75 | –1.5 | | 1.5 | mV |
| Offset temperature drift ⁽³⁾ | | | ± 0.4 | | | ± 0.4 | | ppm/ $^{\circ}\text{C}$ |
| E_G Gain error ⁽³⁾⁽⁵⁾ | | –0.075 | | 0.075 | –0.15 | | 0.15 | %FS |
| Gain temperature drift ⁽³⁾⁽⁵⁾ | | | ± 1.25 | | | ± 1.25 | | ppm/ $^{\circ}\text{C}$ |
| CMRR Common-mode rejection ratio | At DC | | 80 | | | 80 | | dB |
| | [+IN – (–IN)] = $V_{\text{ref}}/2$ with 50 mV _{p-p} common mode signal at 1 MHz | | 55 | | | 55 | | |
| Noise | At 0 V analog input | | 40 | | | 40 | | $\mu\text{V RMS}$ |
| PSRR DC Power supply rejection ratio | At full scale analog input | | 55 | | | 55 | | dB |
| SAMPLING DYNAMICS | | | | | | | | |
| Conversion time | | | 1.0 | 1.16 | | 1.0 | 1.16 | μs |
| Acquisition time | | | 0.50 | | | 0.50 | | μs |
| Throughput rate | | | | 600 | | | 600 | kHz |
| Aperture delay | | | 10 | | | 10 | | ns |
| Aperture jitter | | | 12 | | | 12 | | ps RMS |
| Step response | ⁽⁶⁾ | | 400 | | | 400 | | ns |
| Overvoltage recovery | | | 400 | | | 400 | | ns |

(1) Ideal input span; does not include gain or offset error.

(2) LSB means least significant bit.

(3) Measured using analog input circuit in Figure 51 and digital stimulus in Figure 56 and Figure 57 and reference voltage of 4.096 V.

(4) This is endpoint INL, not best fit.

(5) Measured using external reference source so does not include internal reference voltage error or drift.

(6) Defined as sampling time necessary to settle an initial error of V_{ref} on the sampling capacitor to a final error of 1 LSB at 16-bit level. Measured using the input circuit in Figure 51.

SPECIFICATIONS (continued)

At –40°C to 85°C, +VA = +5 V, +VBD = +5 V or +VBD = +2.7 V, using internal or external reference, $f_{SAMPLE} = 600$ kHz, unless otherwise noted. (All performance parameters are valid only after device has properly resumed from power down, see Table 2.)

| PARAMETER | TEST CONDITIONS | ADS8370IB | | | ADS8370I | | | UNIT | |
|--|---|-------------------------------------|------------|------------|----------|------------|------------|-------|--------|
| | | MIN | TYP | MAX | MIN | TYP | MAX | | |
| DYNAMIC CHARACTERISTICS | | | | | | | | | |
| THD | Total harmonic distortion ⁽⁷⁾⁽⁸⁾ | VIN = 4 V _{p-p} at 1 kHz | –112 | | | –111 | | | dB |
| | | VIN = 4 V _{p-p} at 10 kHz | –111 | | | –111 | | | |
| | | VIN = 4 V _{p-p} at 100 kHz | –92 | | | –92 | | | |
| SNR | Signal-to-noise ratio ⁽⁷⁾ | VIN = 4 V _{p-p} at 1 kHz | 89.5 | | | 89.5 | | | dB |
| | | VIN = 4 V _{p-p} at 10 kHz | 89.5 | | | 89 | | | |
| | | VIN = 4 V _{p-p} at 100 kHz | 89.5 | | | 88.5 | | | |
| SINAD | Signal-to-noise + distortion ⁽⁷⁾⁽⁸⁾ | VIN = 4 V _{p-p} at 1 kHz | 89.5 | | | 89.5 | | | dB |
| | | VIN = 4 V _{p-p} at 10 kHz | 89.5 | | | 89 | | | |
| | | VIN = 4 V _{p-p} at 100 kHz | 87.5 | | | 87 | | | |
| SFDR | Spurious free dynamic range ⁽⁷⁾ | VIN = 4 V _{p-p} at 1 kHz | 119 | | | 119 | | | dB |
| | | VIN = 4 V _{p-p} at 10 kHz | 117 | | | 117 | | | |
| | | VIN = 4 V _{p-p} at 100 kHz | 92 | | | 92 | | | |
| –3dB Small signal bandwidth | | | 75 | | | 75 | | | MHz |
| REFERENCE INPUT | | | | | | | | | |
| V _{ref} | Reference voltage input range | | 2.5 | 4.096 | 4.2 | 2.5 | 4.096 | 4.2 | V |
| | Resistance ⁽⁹⁾ | | 10 | | | 10 | | | MΩ |
| INTERNAL REFERENCE OUTPUT | | | | | | | | | |
| V _{ref} | Reference voltage range | IOUT = 0 A, T _A = 30°C | 4.088 | 4.096 | 4.104 | 4.088 | 4.096 | 4.104 | V |
| | Source current | Static load | 10 | | | 10 | | | μA |
| | Line regulation | +VA = 4.75 V to 5.25 V | 2.5 | | | 2.5 | | | mV |
| | Drift | IOUT = 0 A | 25 | | | 25 | | | ppm/°C |
| DIGITAL INPUT/OUTPUT | | | | | | | | | |
| Logic family CMOS | | | | | | | | | |
| V _{IH} | High level input voltage | | +VBD – 1 | +VBD + 0.3 | | +VBD – 1 | +VBD + 0.3 | | V |
| V _{IL} | Low level input voltage | | –0.3 | 0.8 | | –0.3 | 0.8 | | V |
| V _{OH} | High level output voltage | I _{OH} = 2 TTL loads | +VBD – 0.6 | | | +VBD – 0.6 | | | V |
| V _{OL} | Low level output voltage | I _{OL} = 2 TTL loads | 0.4 | | | 0.4 | | | V |
| Data format: MSB first, 2's complement or straight binary (selectable via the SB/2C pin) | | | | | | | | | |
| POWER SUPPLY REQUIREMENTS | | | | | | | | | |
| Power supply voltage | +VA | | 4.75 | 5 | 5.25 | 4.75 | 5 | 5.25 | V |
| | +VBD | | 2.7 | 3.3 | 5.25 | 2.7 | 3.3 | 5.25 | V |
| I _{CC} | Supply current, 600-kHz sample rate ⁽¹⁰⁾ | +VA = 5 V | 22 | | 25 | 22 | | 25 | mA |
| POWER DOWN | | | | | | | | | |
| I _{CC(PD)} | Supply current, power down | | 2 | | | 2 | | | μA |
| NAP MODE | | | | | | | | | |
| I _{CC(NAP)} | Supply current, nap mode | | 3 | | | 3 | | | mA |
| | Power-up time from nap | | 300 | | | 300 | | | ns |
| TEMPERATURE RANGE | | | | | | | | | |
| | Specified performance | | –40 | 85 | | –40 | 85 | | °C |

(7) Measured using analog input circuit in Figure 51 and digital stimulus in Figure 56 and Figure 57 and reference voltage of 4.096 V.

(8) Calculated on the first nine harmonics of the input frequency.

(9) Can vary +/-30%.

(10) This includes only +VA current. With +VBD = 5 V, +VBD current is typically 1 mA with a 10-pF load capacitance on the digital output pins.

TIMING REQUIREMENTS ⁽¹⁾⁽²⁾⁽³⁾⁽⁴⁾⁽⁵⁾⁽⁶⁾

| PARAMETER | | ADS8370I/ADS8370IB | | | UNIT | REF FIGURE |
|--------------------------------|---|--------------------|-----|------|------|------------------|
| | | MIN | TYP | MAX | | |
| t _{conv} | Conversion time | 1000 | | 1160 | ns | 41 – 44 |
| t _{acq1} | Acquisition time in normal mode | 0.5 | | | μs | 41,42,44 |
| t _{acq2} | Acquisition time in nap mode (t _{acq2} = t _{acq1} + t _{d18}) | 0.8 | | | μs | 43 |
| CONVERSION AND SAMPLING | | | | | | |
| t _{quiet1} | Quiet sampling time (last toggle of interface signals to convert start command) ⁽⁶⁾ | 30 | | | ns | 40 – 43, 45 – 47 |
| t _{quiet2} | Quiet sampling time (convert start command to first toggle of interface signals) ⁽⁶⁾ | 10 | | | ns | 40 – 43, 45 – 47 |
| t _{quiet3} | Quiet conversion time (last toggle of interface signals to fall of BUSY) ⁽⁶⁾ | 600 | | | ns | 40 – 43, 45,47 |
| t _{su1} | Setup time, $\overline{\text{CONVST}}$ before BUSY fall | 15 | | | ns | 41 |
| t _{su2} | Setup time, $\overline{\text{CS}}$ before BUSY fall (only for conversion/sampling control) | 20 | | | ns | 40,41 |
| t _{su4} | Setup time, $\overline{\text{CONVST}}$ before $\overline{\text{CS}}$ rise (so $\overline{\text{CONVST}}$ can be recognized) | 5 | | | ns | 41,43,44 |
| t _{h1} | Hold time, $\overline{\text{CS}}$ after BUSY fall (only for conversion/sampling control) | 0 | | | ns | 41 |
| t _{h3} | Hold time, $\overline{\text{CONVST}}$ after $\overline{\text{CS}}$ rise | 7 | | | ns | 43 |
| t _{h4} | Hold time, $\overline{\text{CONVST}}$ after $\overline{\text{CS}}$ fall (to ensure width of $\overline{\text{CONVST_QUAL}}$) ⁽⁴⁾ | 20 | | | ns | 42 |
| t _{w1} | $\overline{\text{CONVST}}$ pulse duration | 20 | | | ns | 43 |
| t _{w2} | $\overline{\text{CS}}$ pulse duration | 10 | | | ns | 41,42 |
| t _{w5} | Pulse duration, time between conversion start command and conversion abort command to successfully abort the ongoing conversion | | | 1000 | ns | 44 |
| DATA READ OPERATION | | | | | | |
| t _{cyc} | SCLK period | 25 | | | ns | 45 – 47 |
| | SCLK duty cycle | 40% | | 60% | | |
| t _{su5} | Setup time, $\overline{\text{CS}}$ fall before first SCLK fall | 10 | | | ns | 45 |
| t _{su6} | Setup time, $\overline{\text{CS}}$ fall before FS rise | 7 | | | ns | 46,47 |
| t _{su7} | Setup time, FS fall before first SCLK fall | 7 | | | ns | 46,47 |
| t _{h5} | Hold time, $\overline{\text{CS}}$ fall after SCLK fall | 3 | | | ns | 45 |
| t _{h6} | Hold time, FS fall after SCLK fall | 7 | | | ns | 46,47 |
| t _{su2} | Setup time, $\overline{\text{CS}}$ fall before BUSY fall (only for read control) | 20 | | | ns | 40,45 |
| t _{su3} | Setup time, FS fall before BUSY fall (only for read control) | 20 | | | ns | 40,47 |
| t _{h2} | Hold time, $\overline{\text{CS}}$ fall after BUSY fall (only for read control) | 15 | | | ns | 40,45 |
| t _{h8} | Hold time, FS fall after BUSY fall (only for read control) | 15 | | | ns | 40,47 |
| t _{w2} | $\overline{\text{CS}}$ pulse duration | 10 | | | ns | 45 |
| t _{w3} | FS pulse duration | 10 | | | ns | 46,47 |
| MISCELLANEOUS | | | | | | |
| t _{w4} | PD pulse duration for reset and power down | 60 | | | ns | 53,54 |
| | All unspecified pulse durations | 10 | | | ns | |

- (1) All input signals are specified with t_r = t_f = 5 ns (10% to 90% of V_{DD}) and timed from a voltage level of (V_{IL} + V_{IH})/2.
- (2) All specifications typical at –40°C to 85°C, +VA = +4.75 V to +5.25 V, +VBD = +2.7 V to +5.25 V.
- (3) All digital output signals loaded with 10-pF capacitors.
- (4) $\overline{\text{CONVST_QUAL}}$ is $\overline{\text{CONVST}}$ latched by a low value on $\overline{\text{CS}}$ (see Figure 39).
- (5) Reference figure indicated is only a representative of where the timing is applicable and is not exhaustive.
- (6) Quiet time zones are for meeting performance and not functionality.

TIMING CHARACTERISTICS⁽¹⁾⁽²⁾⁽³⁾⁽⁴⁾

| PARAMETER | | ADS8370I/ADS8370IB | | | UNIT | REF FIGURE |
|--------------------------------|--|--|-----|-----------------------------------|---------|------------|
| | | MIN | TYP | MAX | | |
| CONVERSION AND SAMPLING | | | | | | |
| t _{d1} | Delay time, conversion start command to conversion start (aperture delay) | | | 10 | ns | 41,43 |
| t _{d2} | Delay time, conversion end to BUSY fall | | | 5 | ns | 41 – 43 |
| t _{d4} | Delay time, conversion start command to BUSY rise | | | 20 | ns | 41 |
| t _{d3} | Delay time, $\overline{\text{CONVST}}$ rise to sample start | | | 5 | ns | 43 |
| t _{d5} | Delay time, $\overline{\text{CS}}$ fall to sample start | | | 10 | ns | 43 |
| t _{d6} | Delay time, conversion abort command to BUSY fall | | | 10 | ns | 44 |
| DATA READ OPERATION | | | | | | |
| t _{d12} | Delay time, $\overline{\text{CS}}$ fall to MSB valid | 3 | | 15 | ns | 45 |
| t _{d15} | Delay time, FS rise to MSB valid | 6 | | 18 | ns | 46,47 |
| t _{d7} | Delay time, BUSY fall to MSB valid (if FS is high when BUSY falls) | | | 18 | ns | 47 |
| t _{d13} | Delay time, SCLK rise to bit valid | 2 | | 10 | ns | 45–47 |
| t _{d14} | Delay time, $\overline{\text{CS}}$ rise to SDO 3-state | | | 6 | ns | 45 |
| MISCELLANEOUS | | | | | | |
| t _{d10} | Delay time, PD rise to SDO 3-state | | | 55 | ns | 53,54 |
| t _{d18} | Nap mode | | | 300 | ns | 55 |
| | Full power down (external reference used with or without 1- μ F 0.1- μ F capacitor on REFOUT) | | | t _{d11} + 2x conversions | | 54 |
| | Full power down (internal reference used with or without 1- μ F 0.1- μ F capacitor on REFOUT) | | | 25 ⁽⁴⁾ | ms | 53 |
| t _{d11} | Delay time, untrimmed circuit full power-down resume time | | | 1 | ms | 53,54 |
| t _{d16} | Delay time, device power-down time | Nap | | 200 | ns | 55 |
| | | Full power down (internal/external reference used) | | 10 | μ s | 53,54 |
| t _{d17} | Delay time, trimmed internal reference settling (either by turning on supply or resuming from full power-down mode), with 1- μ F 0.1- μ F capacitor on REFOUT | | | 4 | ms | 53 |

- (1) All input signals are specified with t_r = t_f = 5 ns (10% to 90% of V_{DD}) and timed from a voltage level of (V_{IL} + V_{IH})/2.
- (2) All specifications typical at –40°C to 85°C, +VA = +4.75 V to +5.25 V, +VBD = +2.7 V to +5.25 V.
- (3) All digital output signals loaded with 10-pF capacitors.
- (4) Including t_{d11}, two conversions (time to cycle CONVST twice), and t_{d17}.

PIN ASSIGNMENTS

TOP VIEW

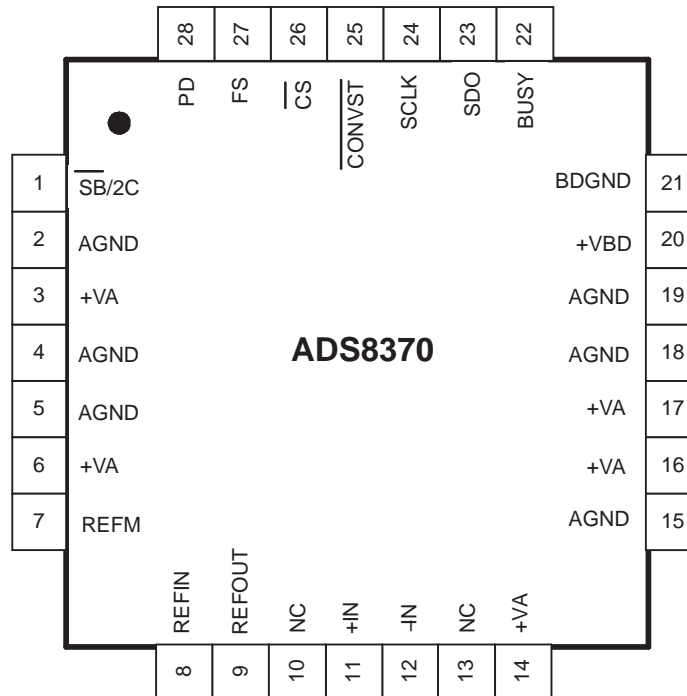

Note: The package thermal pad must be soldered to the printed circuit board for thermal and mechanical performance.

TERMINAL FUNCTIONS

| NAME | PIN | | I/O | DESCRIPTION |
|----------------------------|---------------------|--|-----|---|
| | NO. | | | |
| AGND | 2, 4, 5, 15, 18, 19 | | – | Analog ground pins. AGND must be shorted to analog ground plane below the device. |
| BDGND | 21 | | – | Digital ground for all digital inputs and outputs. BDGND must be shorted to the analog ground plane below the device. |
| BUSY | 22 | | O | Status output. This pin is high when conversion is in progress. |
| $\overline{\text{CONVST}}$ | 25 | | I | Convert start. This signal is qualified with $\overline{\text{CS}}$ internally. |
| $\overline{\text{CS}}$ | 26 | | I | Chip select |
| FS | 27 | | I | Frame sync. This signal is qualified with $\overline{\text{CS}}$ internally. |
| +IN | 11 | | I | Noninverting analog input channel |
| –IN | 12 | | I | Inverting analog input channel |
| NC | 10, 13 | | – | No connection |
| PD | 28 | | I | Power down. Device resets and powers down when this signal is high. |
| REFIN | 8 | | I | Reference (positive) input. REFIN must be decoupled with REFM pin using 0.1- μF bypass capacitor and 1- μF storage capacitor. |
| REFM | 7 | | I | Reference ground. To be connected to analog ground plane. |
| REFOUT | 9 | | O | Internal reference output. Shorted to REFIN pin only when internal reference is used. |
| $\overline{\text{SB/2C}}$ | 1 | | I | Straight binary or 2's complement output data format. When low the device output is straight binary format; when high the device output is 2's complement format. See Table 1 . |
| SCLK | 24 | | I | Serial clock. Data is shifted onto SDO with the rising edge of this clock. This signal is qualified with $\overline{\text{CS}}$ internally. |
| SDO | 23 | | O | Serial data out. All bits except MSB are shifted out at the rising edge of SCLK. |
| +VA | 3, 6, 14, 16, 17 | | – | Analog power supplies |
| +VBD | 20 | | – | Digital power supply for all digital inputs and outputs. |

TYPICAL CHARACTERISTICS

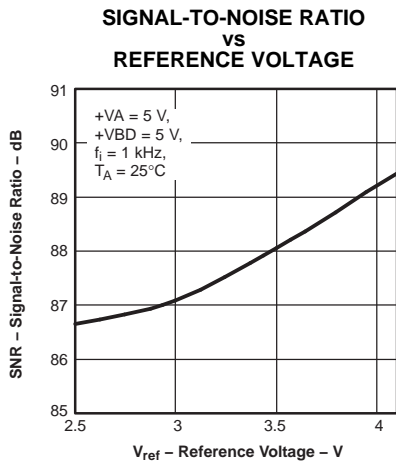

Figure 1.

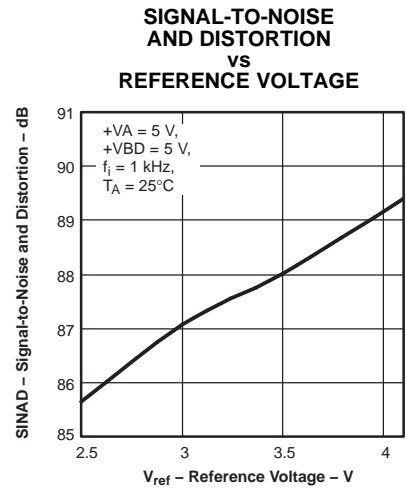

Figure 2.

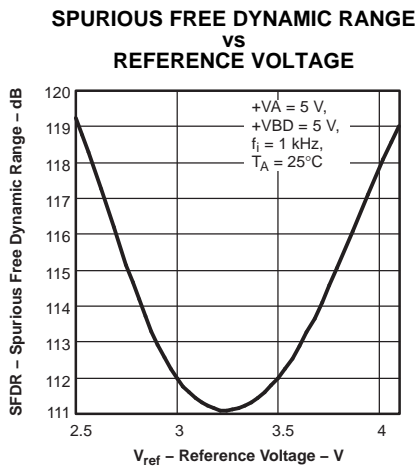

Figure 3.

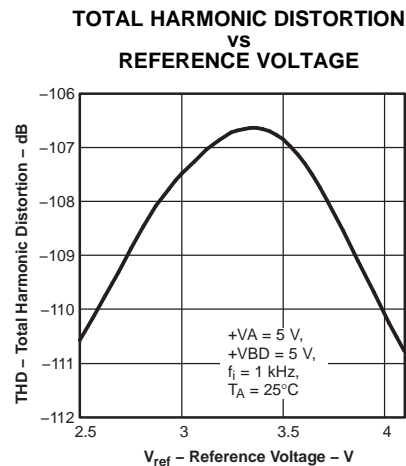

Figure 4.

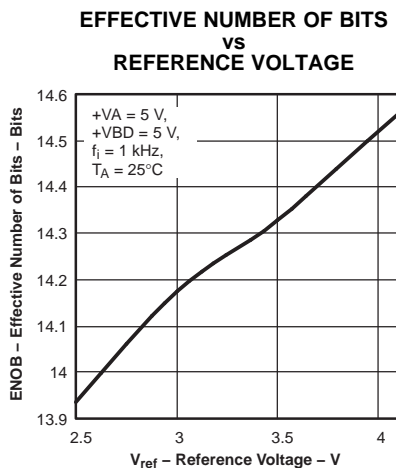

Figure 5.

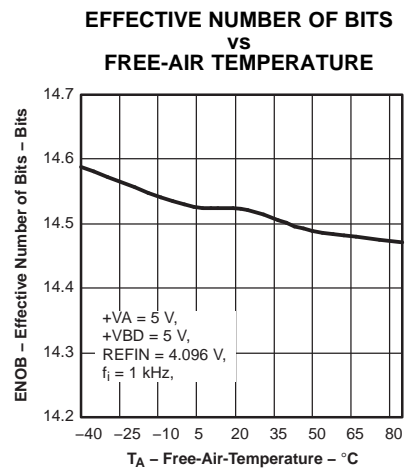

Figure 6.

TYPICAL CHARACTERISTICS (continued)

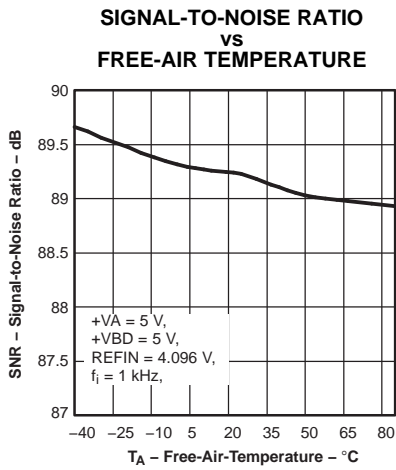

Figure 7.

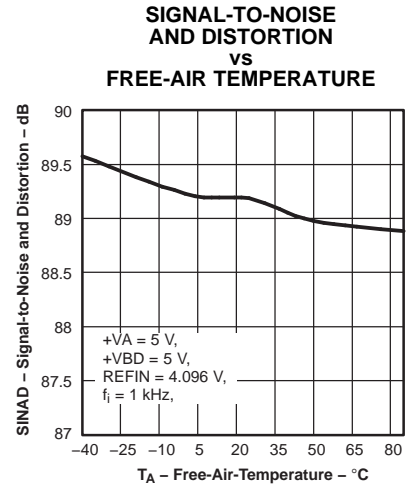

Figure 8.

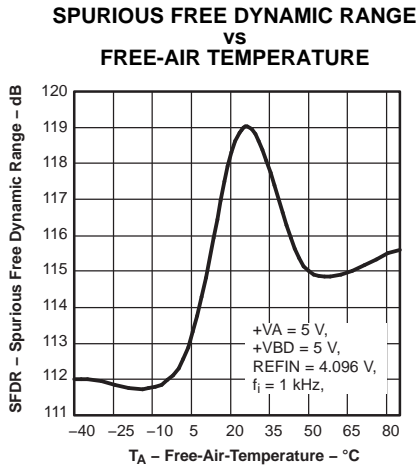

Figure 9.

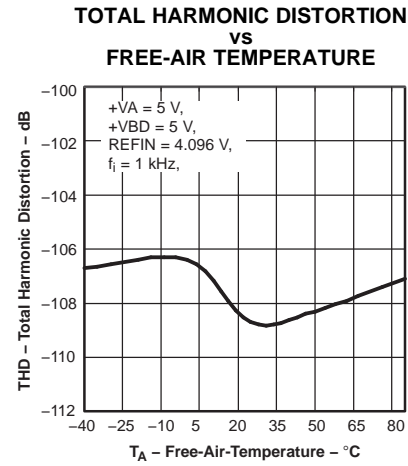

Figure 10.

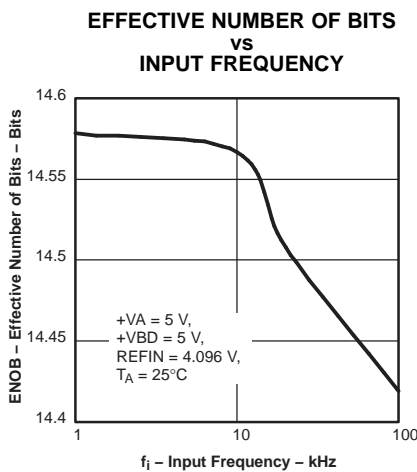

Figure 11.

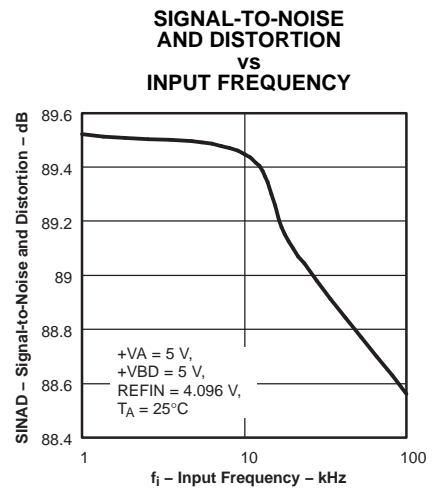

Figure 12.

TYPICAL CHARACTERISTICS (continued)

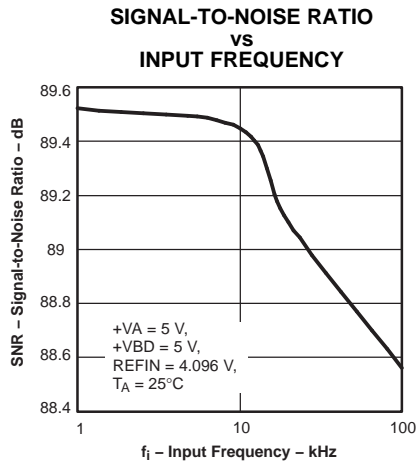

Figure 13.

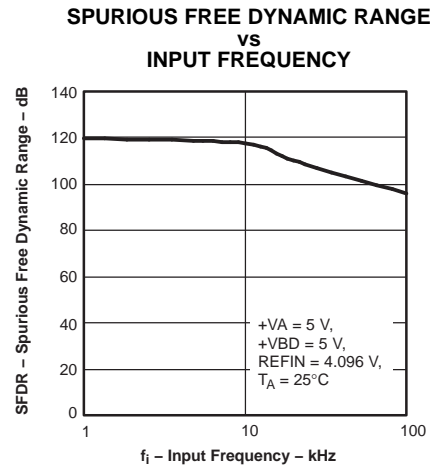

Figure 14.

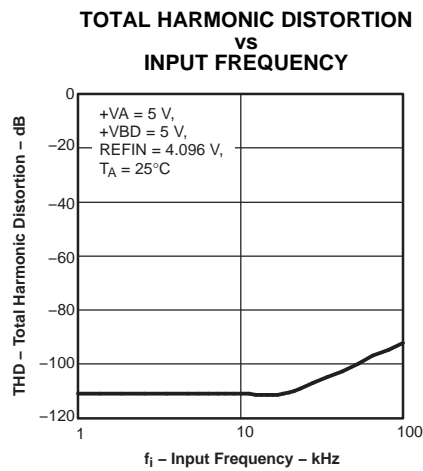

Figure 15.

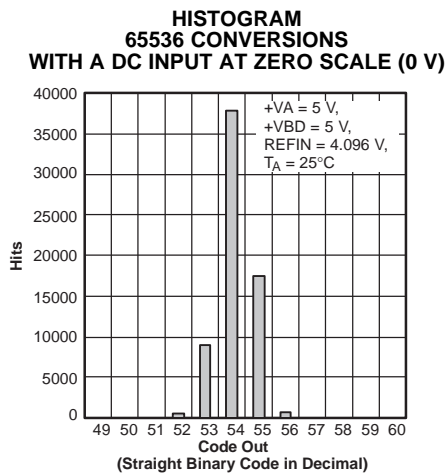

Figure 16.

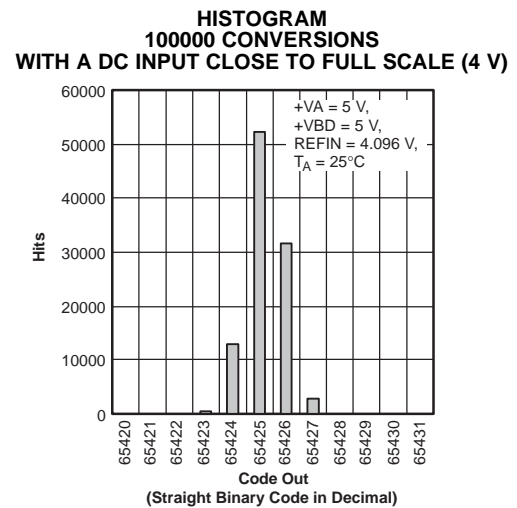

Figure 17.

TYPICAL CHARACTERISTICS (continued)

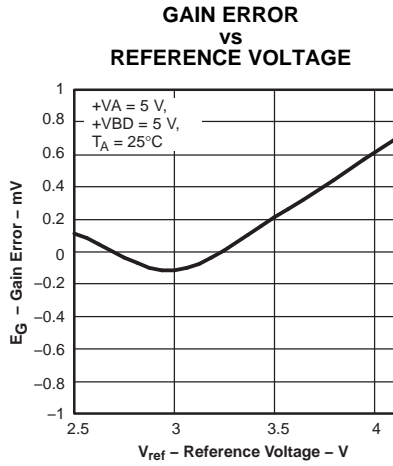

Figure 18.

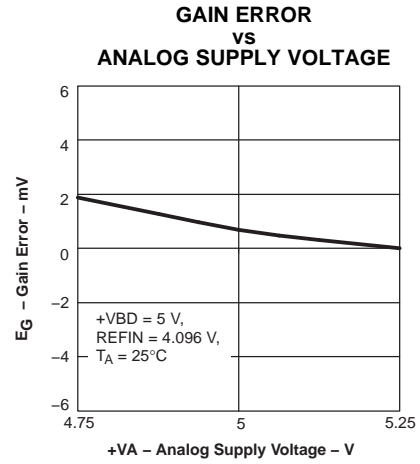

Figure 19.

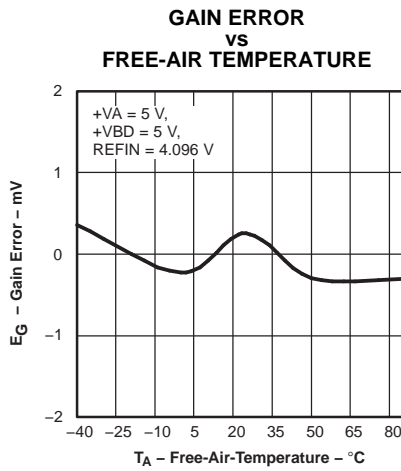

Figure 20.

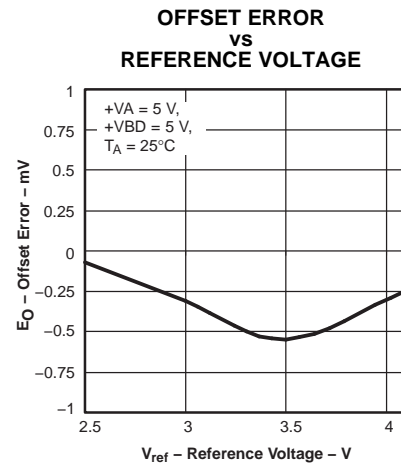

Figure 21.

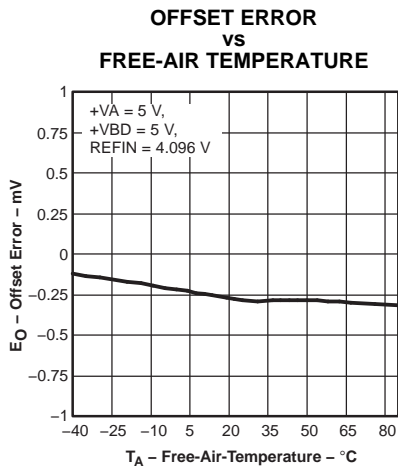

Figure 22.

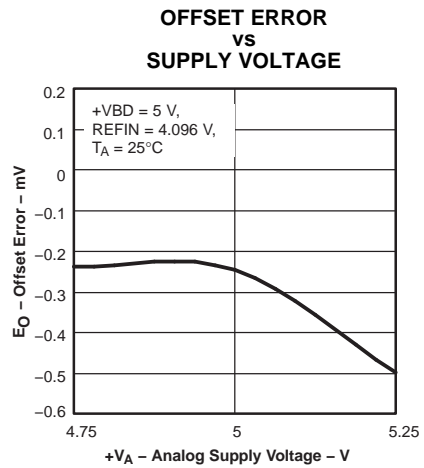

Figure 23.

TYPICAL CHARACTERISTICS (continued)

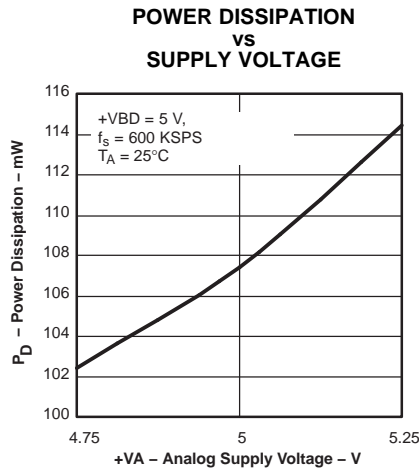

Figure 24.

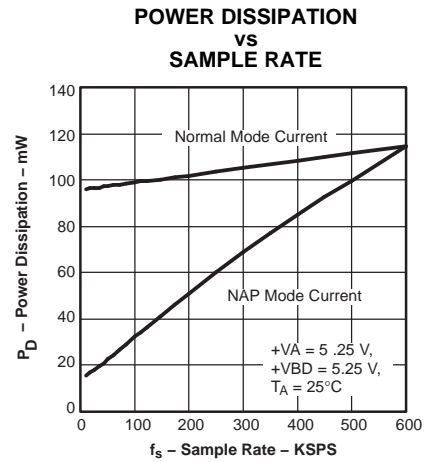

Figure 25.

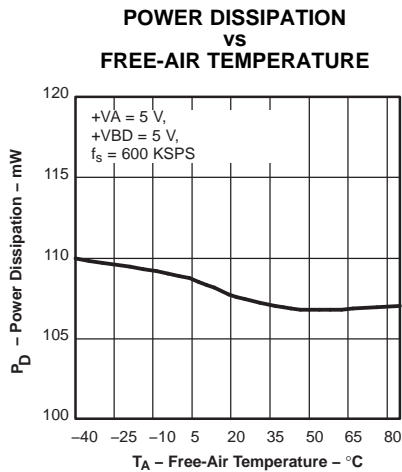

Figure 26.

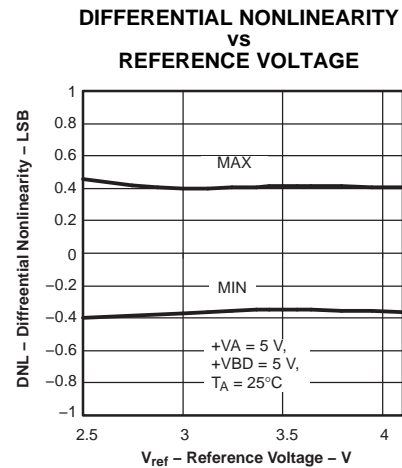

Figure 27.

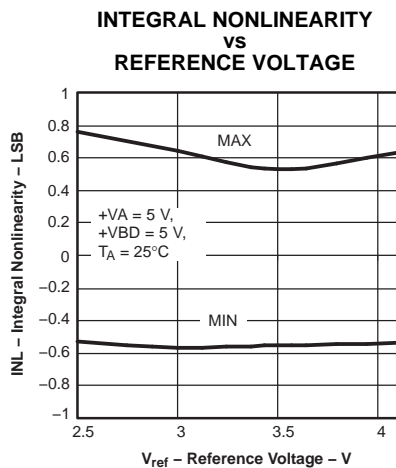

Figure 28.

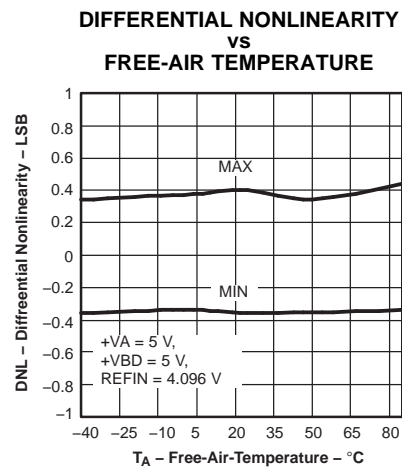

Figure 29.

TYPICAL CHARACTERISTICS (continued)

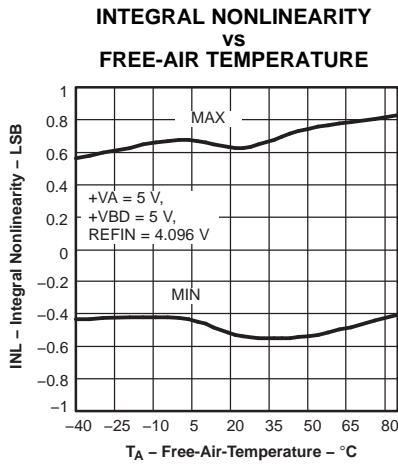

Figure 30.

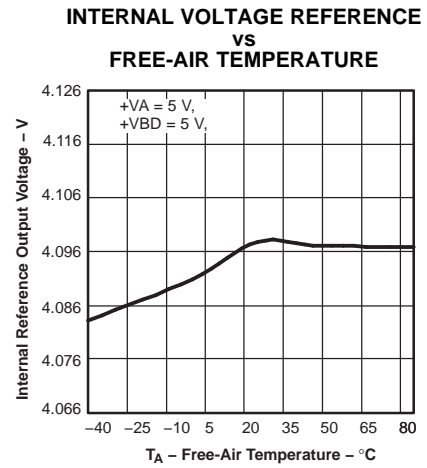

Figure 31.

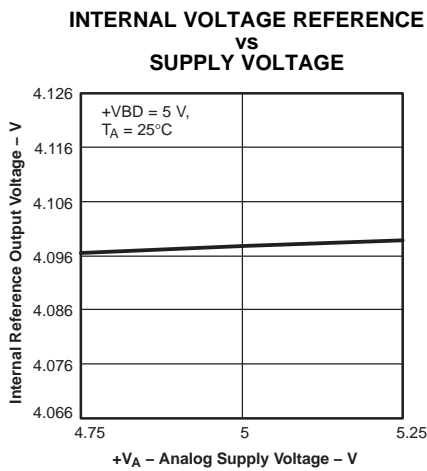

Figure 32.

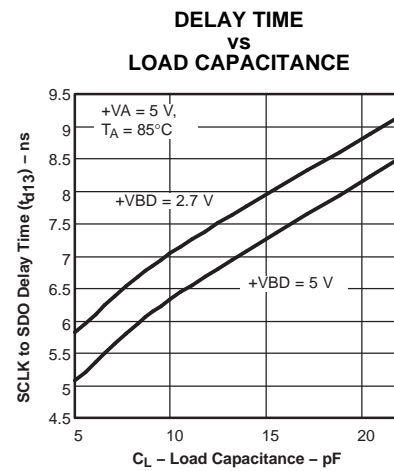

Figure 33.

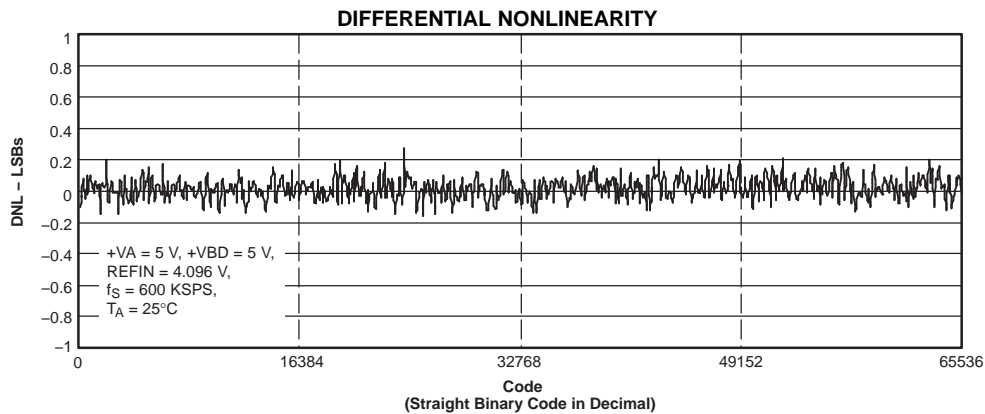
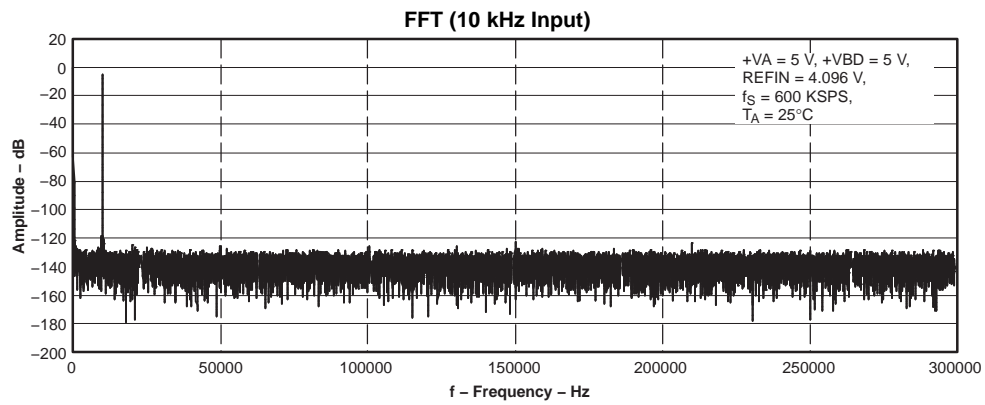
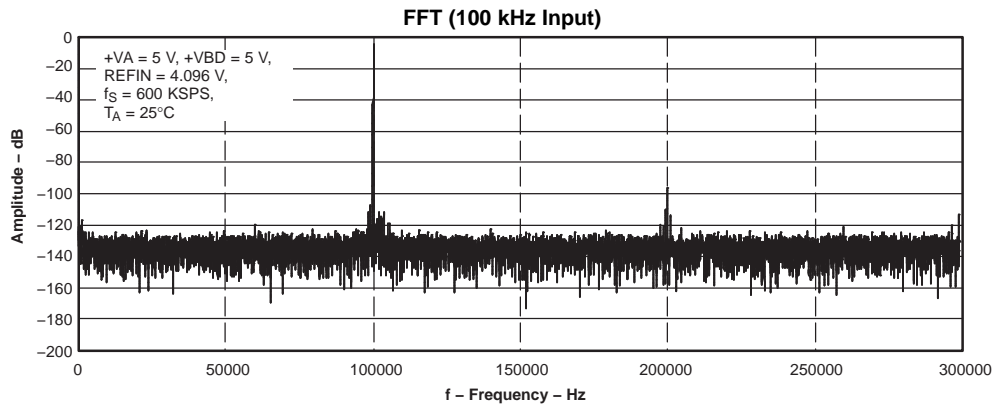
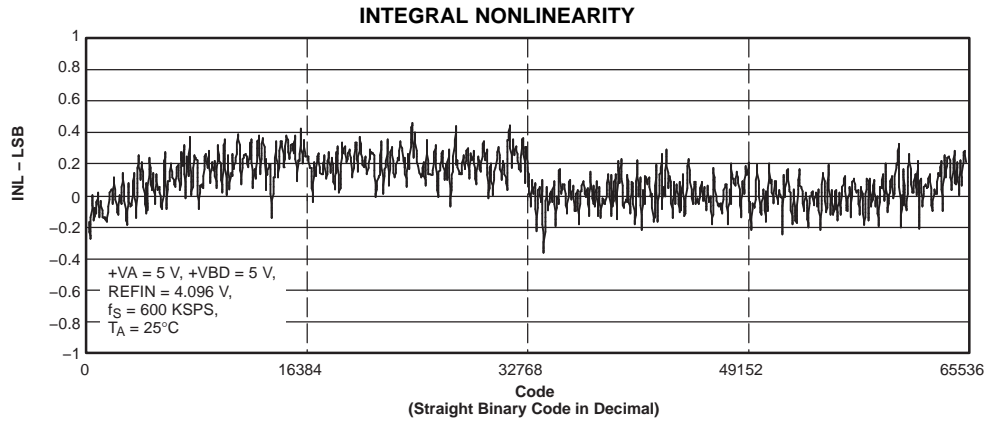
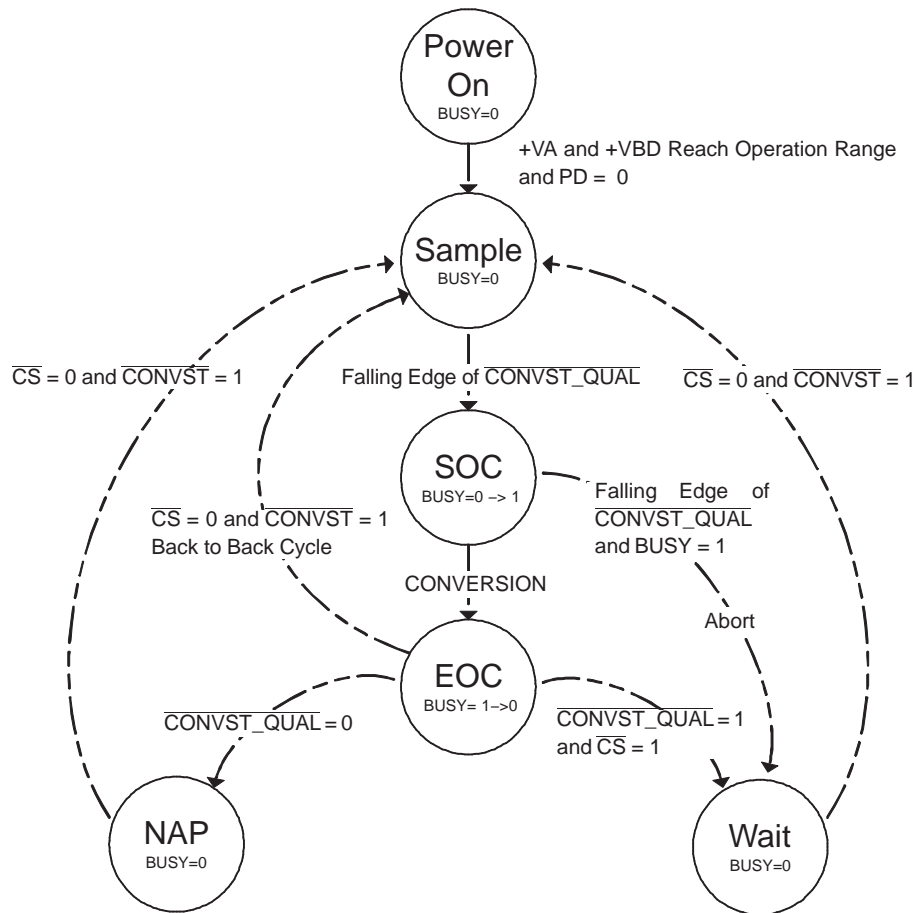

Figure 34.

TYPICAL CHARACTERISTICS (continued)





A. EOC = End of conversion, SOC = Start of conversion, $\overline{CONVST_QUAL}$ is \overline{CONVST} latched by $\overline{CS} = 0$, see Figure 39.

Figure 38. Device States and Ideal Transitions

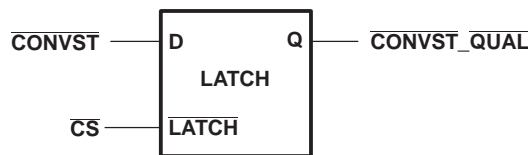

Figure 39. Relationship Between $\overline{CONVST_QUAL}$, \overline{CS} , and \overline{CONVST}

TIMING DIAGRAMS

In the following descriptions, the signal $\overline{CONVST_QUAL}$ represents \overline{CONVST} latched by a low value on \overline{CS} (see Figure 39).

To avoid performance degradation, there are three quiet zones to be observed (t_{quiet1} and t_{quiet2} are zones before and after the falling edge of $\overline{CONVST_QUAL}$ while t_{quiet3} is a time zone before the falling edge of $BUSY$) where there should be no I/O activities. Interface control signals, including the serial clock should remain steady. Typical degradation in performance if these quiet zones are not observed is depicted in the specifications section.

To avoid data loss a read operation should not start around the $BUSY$ falling edge. This is constrained by t_{su2} , t_{su3} , t_{h2} , and t_{h8} .

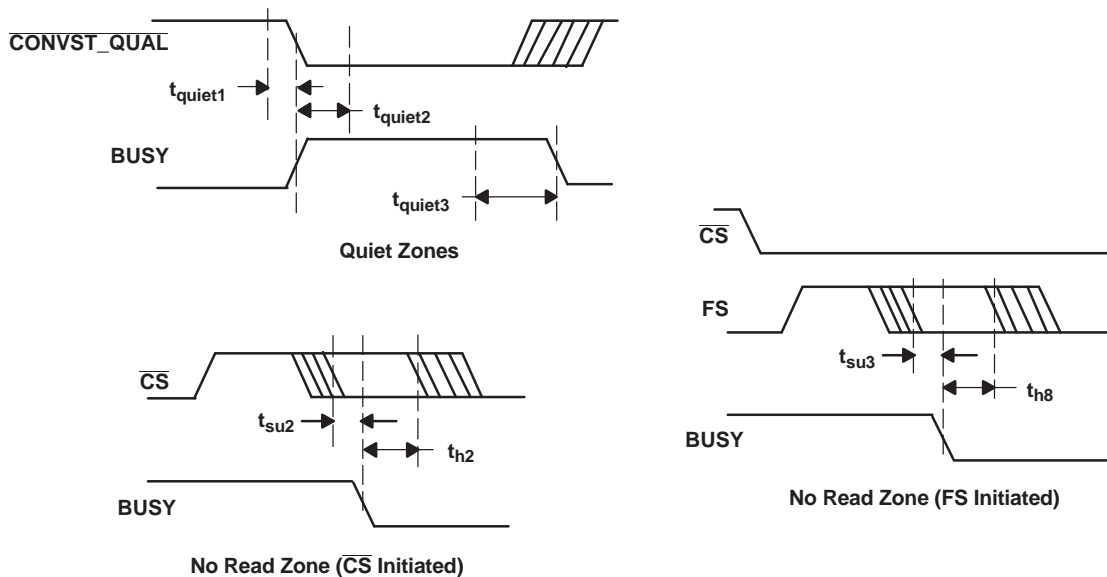

Figure 40. Quiet Zones and No-Read Zones

CONVERSION AND SAMPLING

1. Convert start command:

The device enters the conversion phase from the sampling phase when a falling edge is detected on CONVST_QUAL. This is shown in Figure 41, Figure 42, and Figure 43.

2. Sample (acquisition) start command:

The device starts sampling from the wait state or at the end of a conversion if CONVST_QUAL is detected as high and CS as low. This is shown in Figure 41, Figure 42, and Figure 43.

Maintaining this condition when the device has just finished a conversion (as shown in Figure 41) takes the device immediately into the sampling phase after the conversion phase (back-to-back conversion) and hence achieves maximum throughput. Otherwise, the device enters the wait state.

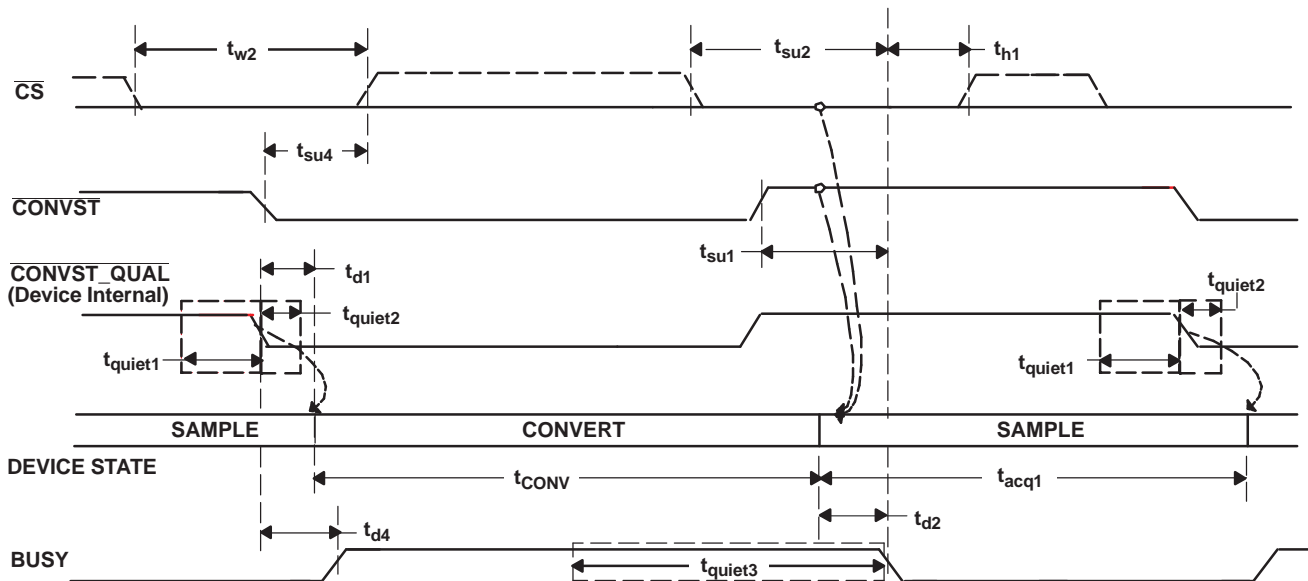

Figure 41. Back-To-Back Conversion and Sample

3. Wait/Nap entry stimulus:

The device enters the wait phase at the end of the conversion if the sample start command is not given. This is shown in Figure 42.

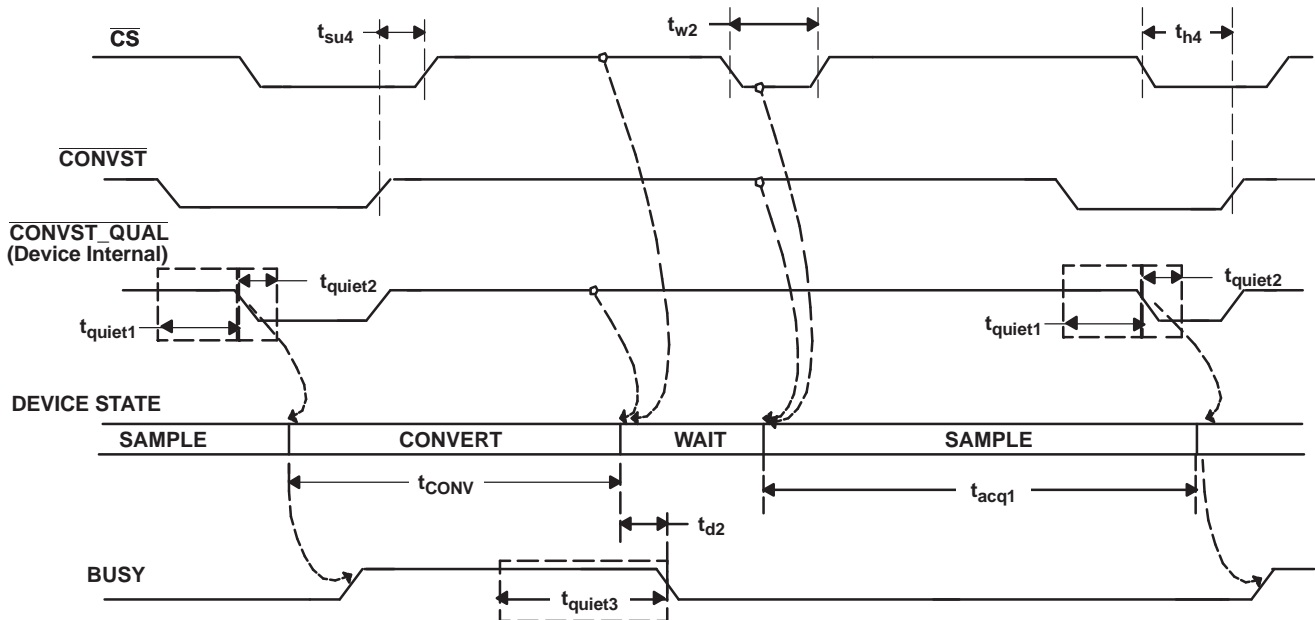

Figure 42. Convert and Sample with Wait

If lower power dissipation is desired and throughput can be compromised, a nap state can be inserted in between cycles (as shown in Figure 43). The device enters a low power (3 mA) state called nap if the end of the conversion happens when $\overline{CONVST_QUAL}$ is low. The cost for using this special wait state is a longer sampling time (t_{acq2}) plus the nap time.

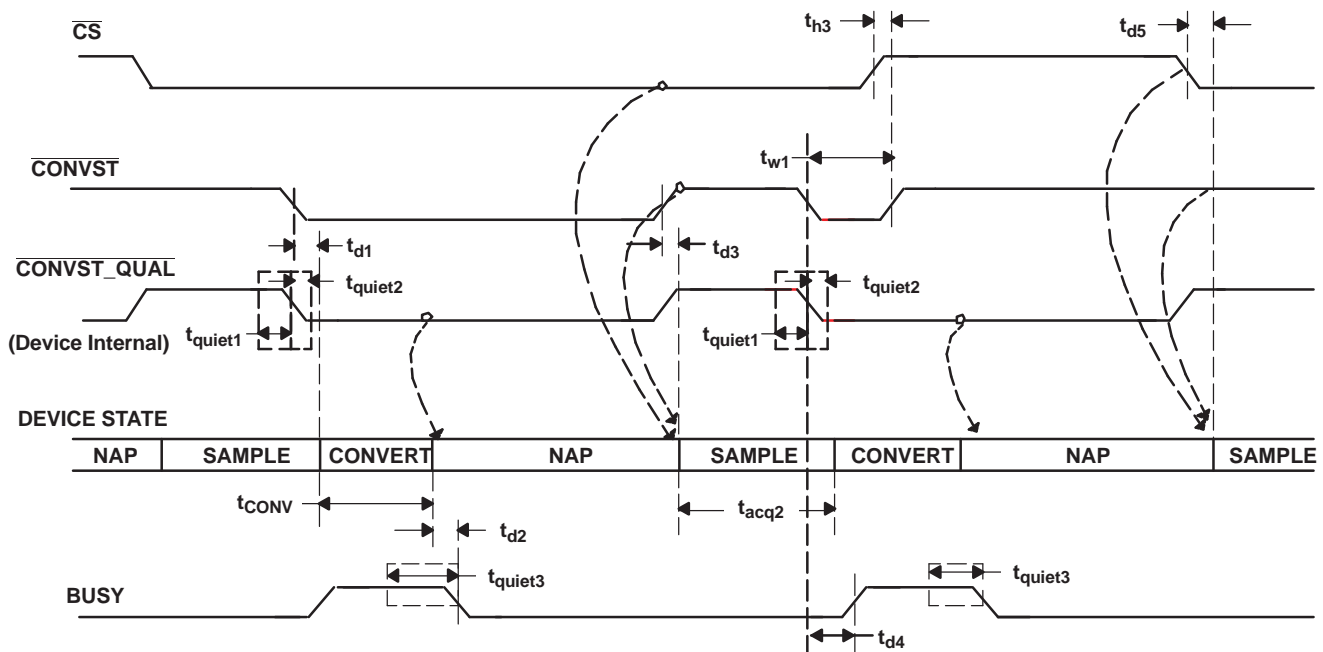

Figure 43. Convert and Sample with Nap

4. Conversion abort command

An ongoing conversion can be aborted by using the conversion abort command. This is done by forcing another start of conversion (a valid CONVST_QUAL falling edge) onto an ongoing conversion as shown in Figure 44. The device enters the wait state after an aborted conversion. If the previous conversion was successfully aborted, the device output reads 0xFF00 on SDO.

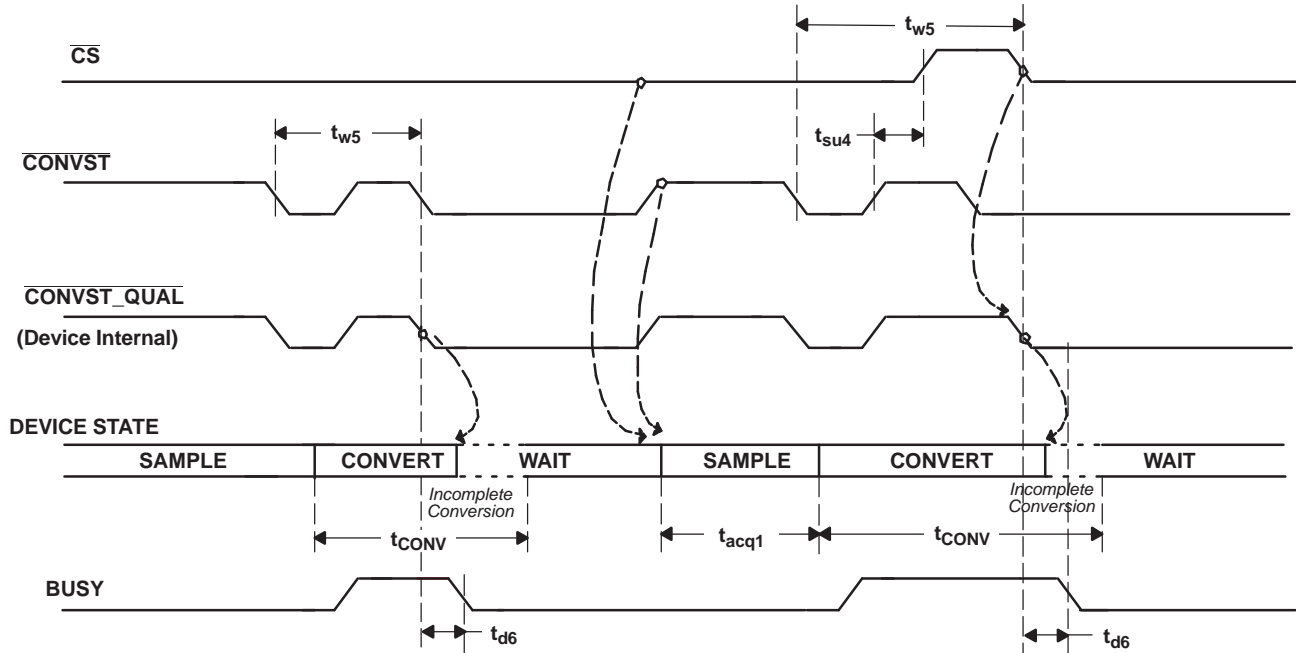

Figure 44. Conversion Abort

DATA READ OPERATION

Data read control is independent of conversion control. Data can be read either during conversion or during sampling. Data that is read during a conversion involves latency of one sample. The start of a new data frame around the fall of BUSY is constrained by t_{su2} , t_{su3} , t_{h2} , and t_{h8} .

1. SPI Interface:

A data read operation in SPI interface mode is shown in Figure 45. FS must be tied high for operating in this mode. The MSB of the output data is available at the falling edge of \overline{CS} . MSB – 1 is shifted out at the first rising edge after the first falling edge of SCLK after \overline{CS} falling edge. Subsequent bits are shifted at the subsequent rising edges of SCLK. If another data frame is attempted (by pulling \overline{CS} high and subsequently low) during an active data frame, then the ongoing frame is aborted and a new frame is started.

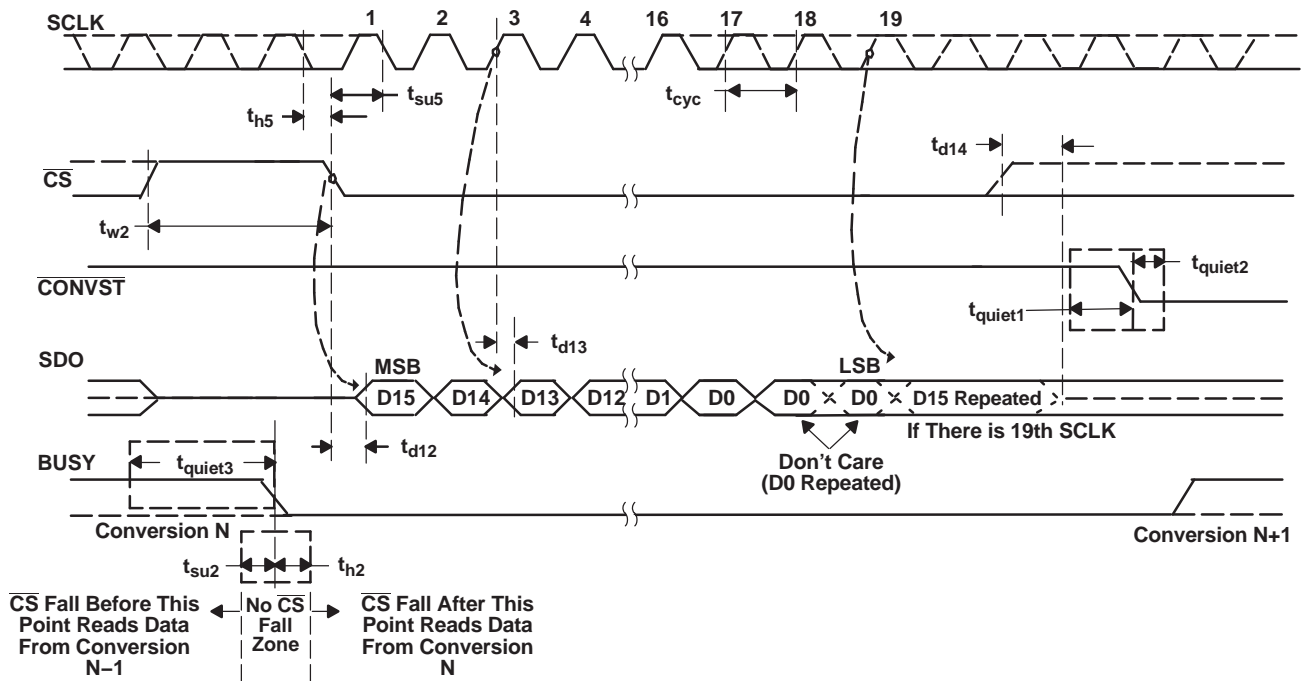

Figure 45. Read Frame Controlled via \overline{CS} (FS = 1)

If another data frame is attempted (by pulling \overline{CS} high and then low) during an active data frame, then the ongoing frame is aborted and a new frame is started.

2. Serial interface using FS:

A data read operation in this mode is shown in Figure 46 and Figure 47. The MSB of the output data is available at the rising edge of FS. MSB – 1 is shifted out at the first rising edge after the first falling edge of SCLK after the FS falling edge. Subsequent bits are shifted at the subsequent rising edges of SCLK.

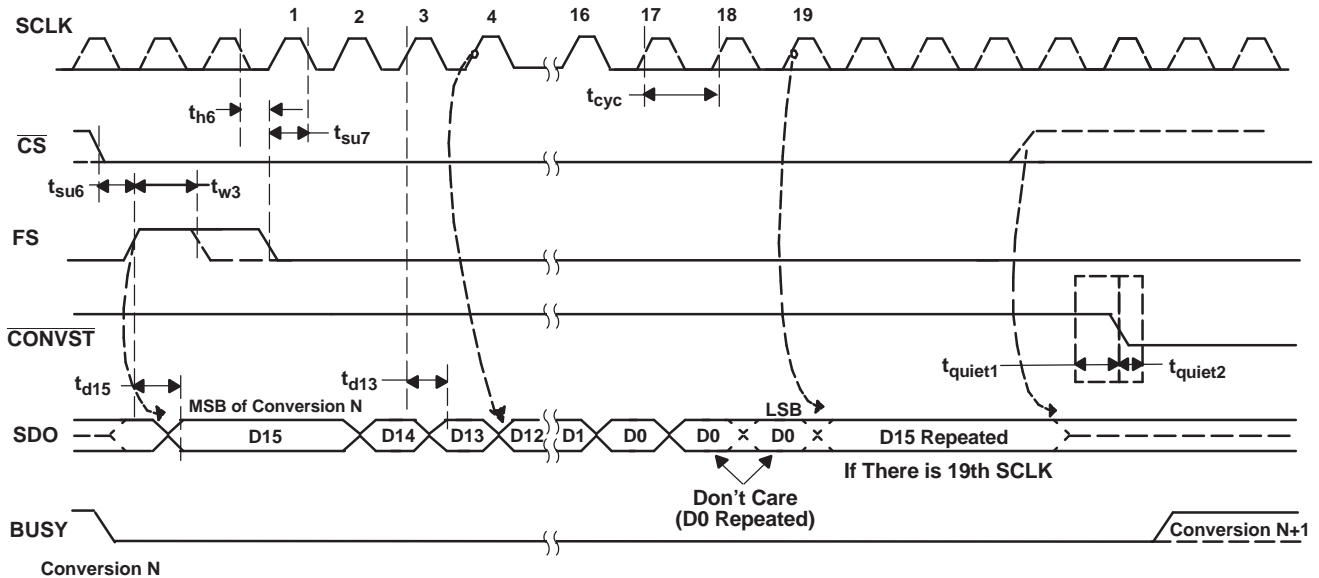

Figure 46. Read Frame Controlled via FS (FS is Low When BUSY Falls)

If FS is high when BUSY falls, the SDO is updated again with the new MSB when BUSY falls. This is shown in Figure 47.

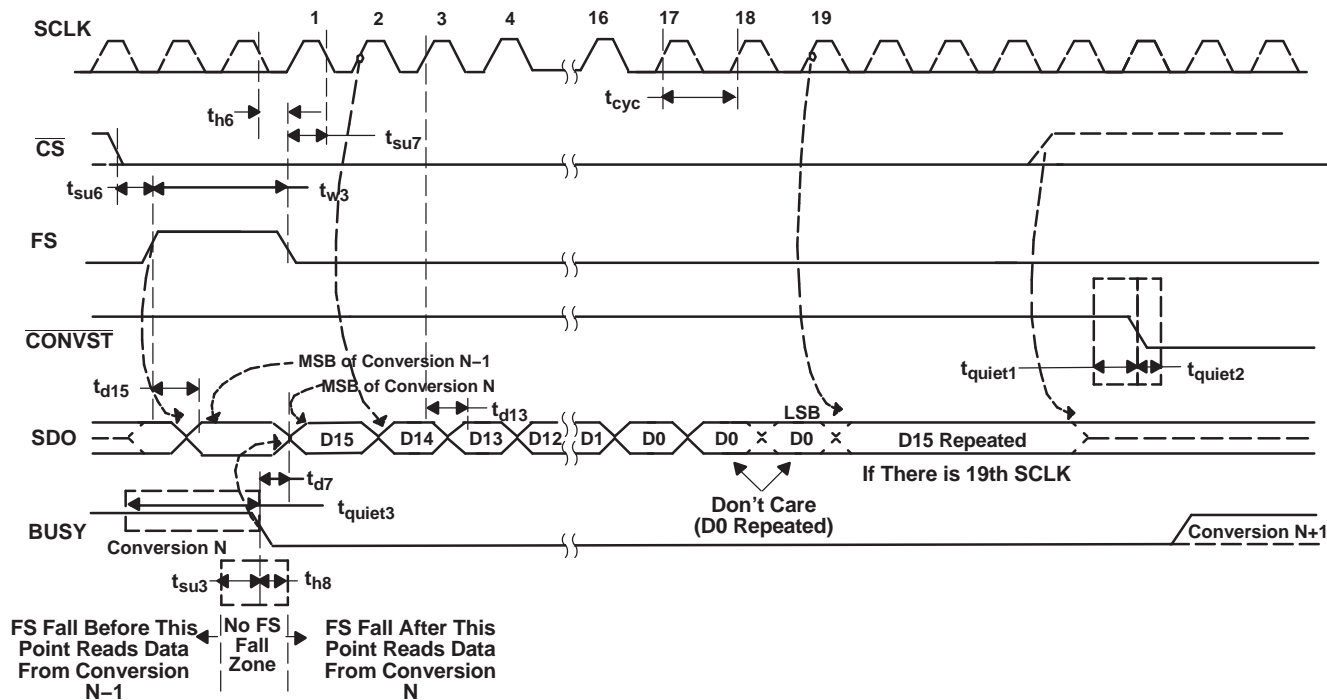

Figure 47. Read Frame Controlled via FS (FS is High When BUSY Falls)

If another data frame is attempted by pulling up FS during an active data frame, then the ongoing frame is aborted and a new frame is started.

PRINCIPLES OF OPERATION

The ADS8370 is a high-speed successive approximation register (SAR) analog-to-digital converter (ADC). The architecture is based on charge redistribution, which inherently includes a sample/hold function.

The device includes a built-in conversion clock, internal reference, and 40-MHz SPI compatible serial interface. The maximum conversion time is 1.16 μ s which is capable of sustaining a 600-kHz throughput.

The analog input is provided to the two input pins: +IN and –IN. When a conversion is initiated, the differential input on these pins is sampled on the internal capacitor array. While a conversion is in progress, both inputs are disconnected from any internal function.

REFERENCE

The ADS8370 has a built-in 4.096-V (nominal value) reference but can operate with an external reference also. When the internal reference is used, pin 9 (REFOUT) should be shorted to pin 8 (REFIN) and a 0.1- μ F decoupling capacitor and a 1- μ F storage capacitor must be connected between pin 8 (REFIN) and pin 7 (REFM) (see Figure 48). The internal reference of the converter is buffered.

PRINCIPLES OF OPERATION (continued)

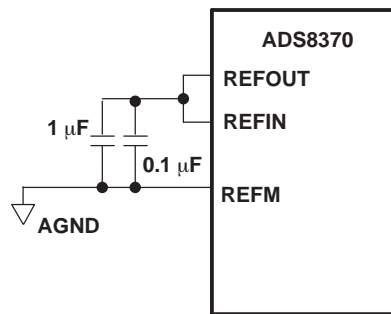

Figure 48. ADS8370 Using Internal Reference

The REFIN pin is also internally buffered. This eliminates the need to put a high bandwidth buffer on the board to drive the ADC reference and saves system area and power. When an external reference is used, the reference must be of low noise, which may be achieved by the addition of bypass capacitors from the REFIN pin to the REFM pin. See Figure 49 for operation of the ADS8370 with an external reference. REFM must be connected to the analog ground plane.

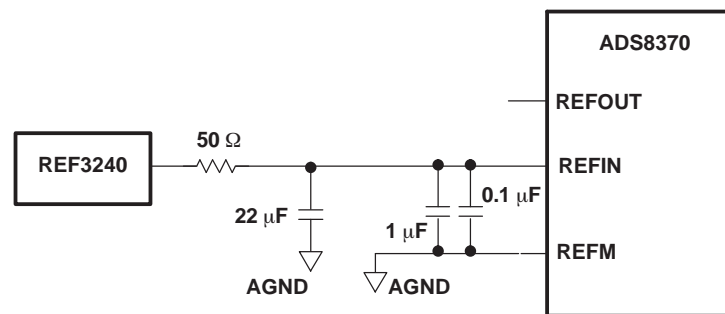

Figure 49. ADS8370 Using External Reference

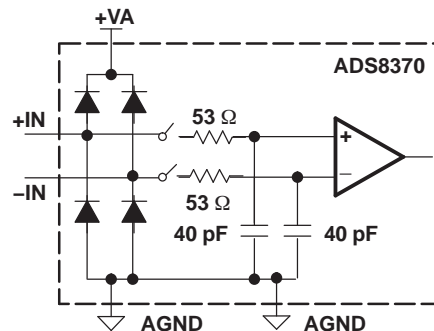

Figure 50. Simplified Analog Input

ANALOG INPUT

When the converter enters hold mode, the voltage difference between the +IN and –IN inputs is captured on the internal capacitor array. The +IN input has a range of –0.2 V to (+V_{REF} + 0.2 V), whereas the –IN input has a range of –0.2 V to +0.2 V. The input span [+IN – (–IN)] is limited from 0 V to V_{REF}.

The input current on the analog inputs depends upon throughput and the frequency content of the analog input

PRINCIPLES OF OPERATION (continued)

signals. Essentially, the current into the ADS8370 charges the internal capacitor array during the sampling (acquisition) time. After this capacitance has been fully charged, there is no further input current. The source of the analog input voltage must be able to charge the device sampling capacitance (40 pF each from +IN/–IN to AGND) to an 16-bit settling level within the sampling (acquisition) time of the device. When the converter goes into hold mode, the input resistance is greater than 1 G Ω .

Care must be taken regarding the absolute analog input voltage. To maintain the linearity of the converter, the +IN, –IN inputs and the span [+IN – (–IN)] should be within the limits specified. Outside of these ranges, the converter's linearity may not meet specifications.

Care should be taken to ensure that the output impedance of the sources driving +IN and –IN inputs are matched. If this is not observed, the two inputs can have different settling times. This can result in offset error, gain error, and linearity error which vary with temperature and input voltage.

A typical input circuit using TI's THS4031 is shown in [Figure 52](#). In the figure, input from a bipolar source is converted to a unipolar signal for the ADS8370. In the case where the source signal is in range for the ADS8370, the circuit in [Figure 51](#) may be used. Most of the specified performance figure were measured using the circuit in [Figure 51](#).

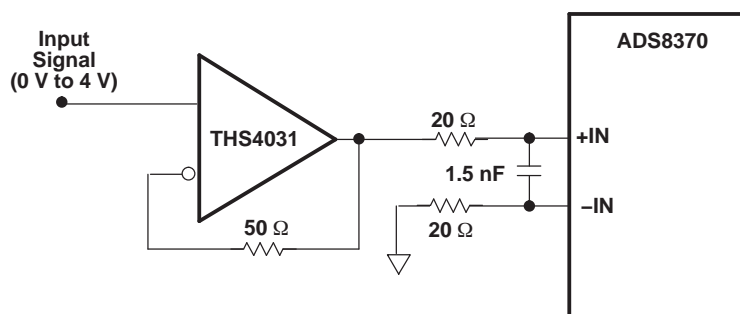

Figure 51. Unipolar Input Drive Configuration

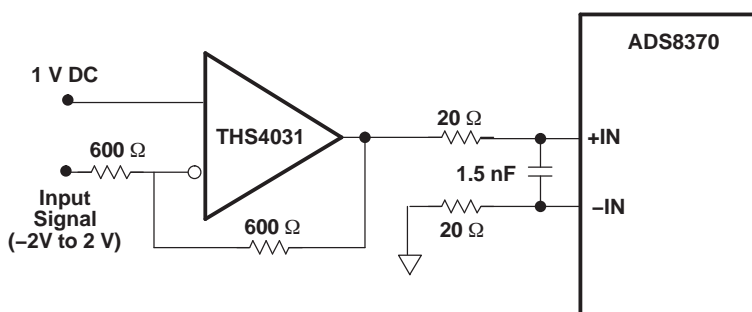

Figure 52. Bipolar Input Drive Configuration

DIGITAL INTERFACE

TIMING AND CONTROL

Conversion and sampling are controlled by the $\overline{\text{CONVST}}$ and $\overline{\text{CS}}$ pins. See the timing diagrams for detailed information on timing signals and their requirements. The ADS8370 uses an internally generated clock to control the conversion rate and in turn the throughput of the converter. SCLK is used for reading converted data only. A clean and low jitter conversion start command is important for the performance of the converter. There is a minimal quiet zone requirement around the conversion start command as mentioned in the timing requirements table.

DIGITAL INTERFACE (continued)

READING DATA

The ADS8370 offers a high speed serial interface that is compatible with the SPI protocol. The device outputs data in either 2's complement format or straight binary format depending on the state of the $\overline{SB}/2C$ pin. Refer to [Table 1](#) for the ideal output codes.

Table 1. Input Voltages and Ideal Output Codes

| DESCRIPTION | ANALOG VALUE +IN – (–IN) | DIGITAL OUTPUT (HEXADECIMAL) | |
|-----------------------------|--------------------------------|------------------------------|----------------------------|
| Full-scale range | $(+V_{REF})$ | $\overline{SB}/2C$ Pin = 0 | $\overline{SB}/2C$ Pin = 1 |
| Least significant bit (LSB) | $(+V_{REF})/2^{16}$ | | |
| Full scale | $V_{REF} - 1 \text{ LSB}$ | FFFF | 7FFF |
| Mid scale | $(+V_{REF})/2$ | 8000 | 0000 |
| Mid scale – 1 LSB | $(+V_{REF})/2 - 1 \text{ LSB}$ | 7FFF | FFFF |
| 0 | 0 | 0000 | 8000 |

To avoid performance degradation due to the toggling of device buffers, read operation must not be performed in the specified quiet zones (t_{quiet1} , t_{quiet2} , and t_{quiet3}). Internal to the device, the previously converted data is updated with the new data near the fall of BUSY. Hence, the fall of \overline{CS} and the fall of FS around the fall of BUSY is constrained. This is specified by t_{su2} , t_{su3} , t_{h2} , and t_{h8} in the timing requirements table.

POWER SAVING

The converter provides two power saving modes, full power down and nap. Refer to [Table 2](#) for information on activation/deactivation and resumption time for both modes.

Table 2. Power Save

| TYPE OF POWER DOWN | SDO | POWER CONSUMPTION | ACTIVATED BY | ACTIVATION TIME (t_{d16}) | RESUME POWER BY |
|---|------------------------------|-------------------|--|-------------------------------|----------------------|
| Normal operation | Not 3 stated | 22 mA | NA | NA | NA |
| Full power down (Int Ref, 1- μ F capacitor on REFOUT pin) | 3 Stated (t_{d10} timing) | 2 μ A | PD = 1 | 10 μ s | PD = 0 |
| Full power down (Ext Ref, 1- μ F capacitor on REFOUT pin) | 3 Stated (t_{d10} timing) | 2 μ A | PD = 1 | 10 μ s | PD = 0 |
| Nap power down | Not 3 stated | 3 mA | At EOC and $\overline{CONVST_QUAL} = 0$ | 200 ns | Sample Start command |

FULL POWER-DOWN MODE

Full power-down mode is activated by turning off the supply or by asserting PD to 1. See [Figure 53](#) and [Figure 54](#). The device can be resumed from full power down by either turning on the power supply or by de-asserting the PD pin. The first two conversions produce inaccurate results because during this period the device loads its trim values to ensure the specified accuracy.

If an internal reference is used (with a 1- μ F capacitor installed between the REFOUT and REFM pins), the total resume time (t_{d18}) is 25 ms. After the first two conversions, t_{d17} (4 ms) is required for the trimmed internal reference voltage to settle to the specified accuracy. Only then the converted results match the specified accuracy.

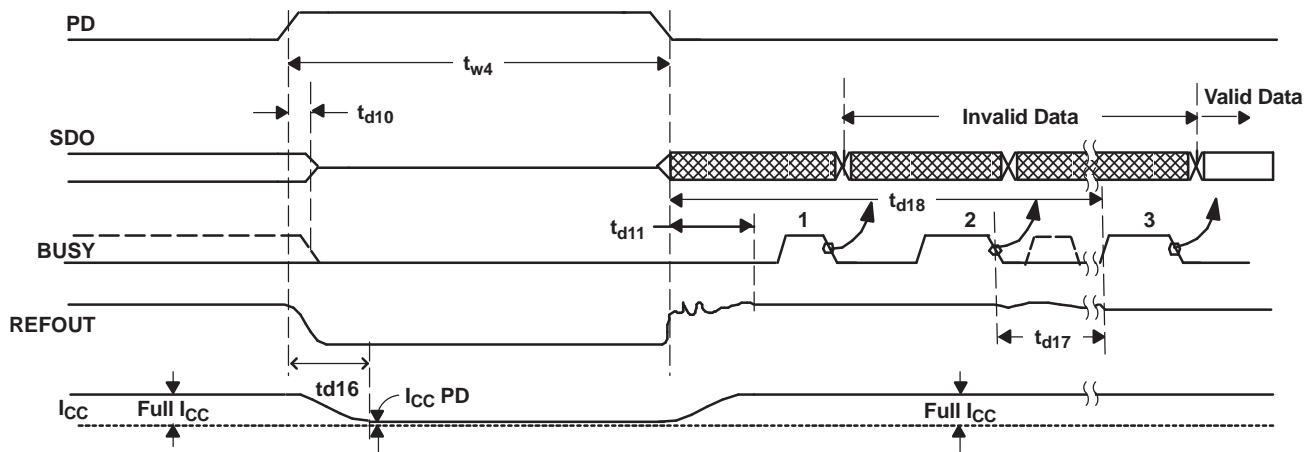

Figure 53. Device Full Power Down/Resume (Internal Reference Used)

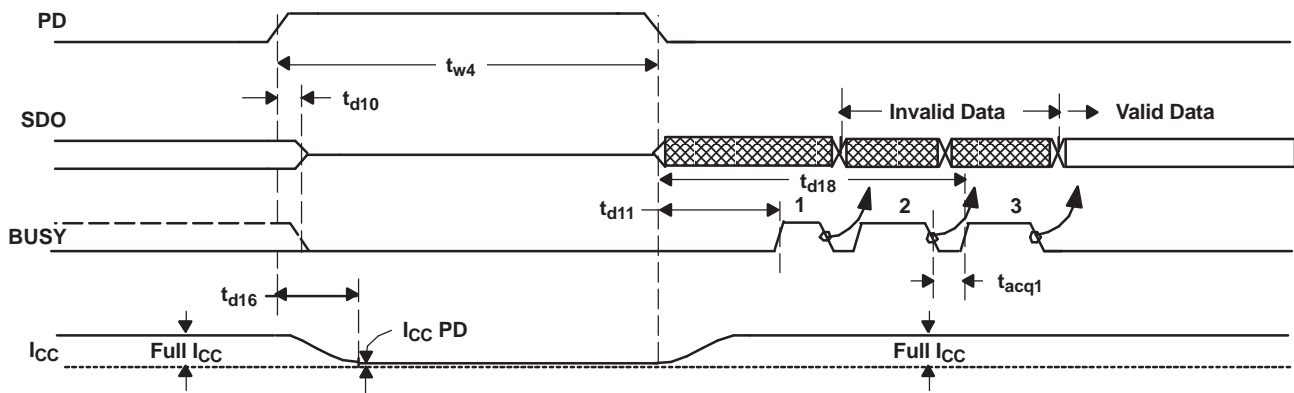

Figure 54. Device Full Power Down/Resume (External Reference Used)

NAP MODE

Nap mode is automatically inserted at the end of a conversion if $\overline{\text{CONVST_QUAL}}$ is held low at EOC. The device can be operated in nap mode at the end of every conversion for saving power at lower throughputs. Another way to use this mode is to convert multiple times and then enter nap mode. The minimum sampling time after a nap state is $t_{\text{acq1}} + t_{\text{d18}} = t_{\text{acq2}}$.

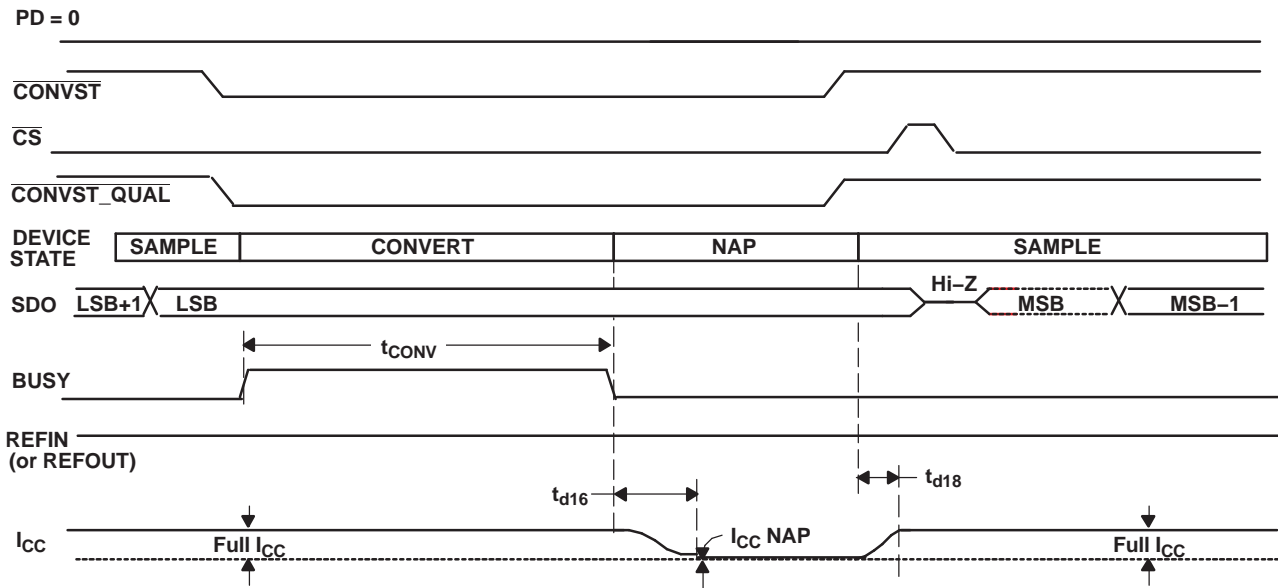

Figure 55. Device Nap Power Down/Resume

LAYOUT

For optimum performance, care should be taken with the physical layout of the ADS8370 circuitry.

Since the ADS8370 offers single-supply operation, it is often used in close proximity with digital logic, microcontrollers, microprocessors, and digital signal processors. The more the digital logic in the design and the higher the switching speed, the greater the need for better layout and isolation of the critical analog signals from these switching digital signals.

The basic SAR architecture is sensitive to glitches or sudden changes on the power supply, reference, ground connections and digital inputs that occur just prior to the end of sampling and just prior to the latching of the analog comparator. Such glitches might originate from switching power supplies, nearby digital logic, or high power devices. Noise during the end of sampling and the latter half of the conversion must be kept to a minimum (the former half of the conversion is not very sensitive since the device uses a proprietary error correction algorithm to correct for the transient errors made here).

The degree of error in the digital output depends on the reference voltage, layout, and the exact timing and degree of the external event.

On average, the ADS8370 draws very little current from an external reference as the reference voltage is internally buffered. If the reference voltage is external, it must be ensured that the reference source can drive the bypass capacitor without oscillation. A 0.1- μ F bypass capacitor is recommended from pin 8 directly to pin 7 (REFM).

The AGND and BDGND pins should be connected to a clean ground point. In all cases, this should be the *analog* ground. Avoid connections that are too close to the grounding point of a microcontroller or digital signal processor. If required, run a ground trace directly from the converter to the power supply entry point. The ideal layout consists of an analog ground plane dedicated to the converter and associated analog circuitry.

As with the AGND connections, +VA should be connected to a +5-V power-supply plane or trace that is separate from the connection for digital logic until they are connected at the power entry point. Power to the ADS8370 should be clean and well bypassed. A 0.1- μ F ceramic bypass capacitor should be placed as close to the device as possible. See Table 3 for the placement of these capacitors. In addition, a 1- μ F capacitor is recommended. In some situations, additional bypassing may be required, such as a 100- μ F electrolytic capacitor or even a *Pi* filter made up of inductors and capacitors—all designed to essentially low-pass filter the +5-V supply, removing the high frequency noise.

Table 3. Power Supply Decoupling Capacitor Placement

| SUPPLY PINS | CONVERTER ANALOG SIDE | CONVERTER DIGITAL SIDE |
|---|--------------------------------|------------------------|
| Pair of pins requiring a shortest path to decoupling capacitors | (2,3); (5,6); (15,16); (17,18) | (20,21) |
| Pins requiring no decoupling | 4, 14, 19 | |

When using the internal reference, ensure a shortest path from REFOUT (pin 9) to REFIN (pin 8) with the bypass capacitor directly between pins 8 and 7.

APPLICATION INFORMATION

EXAMPLE DIGITAL STIMULUS

The use of the ADS8370 is very straightforward. The following timing diagram shows one example of how to achieve a 600-KSPS throughput using a SPI compatible serial interface.

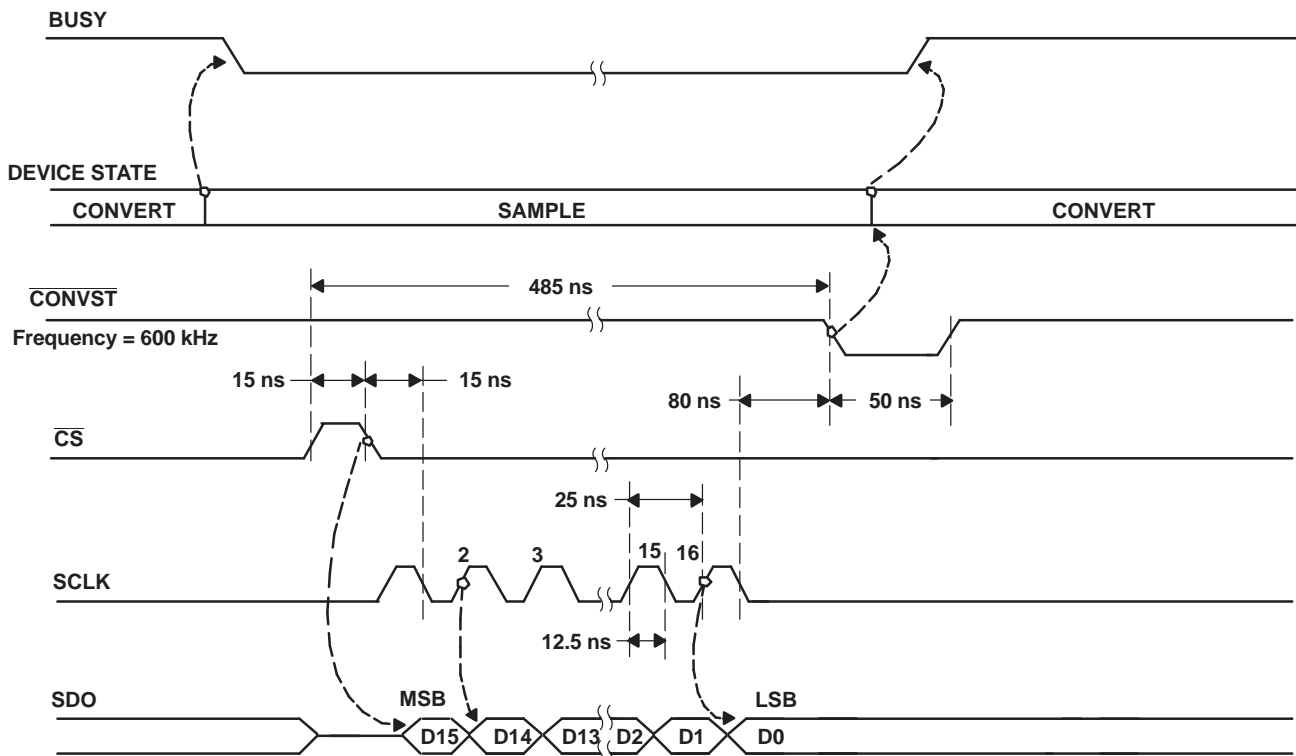

Figure 56. Example Stimulus in SPI Mode (FS =1), Back-To-Back Conversion that Achieves 600 KSPS

APPLICATION INFORMATION (continued)

It is also possible to use the frame sync signal, FS. The following timing diagram shows how to achieve a 600-KSPS throughput using a modified serial interface with FS active.

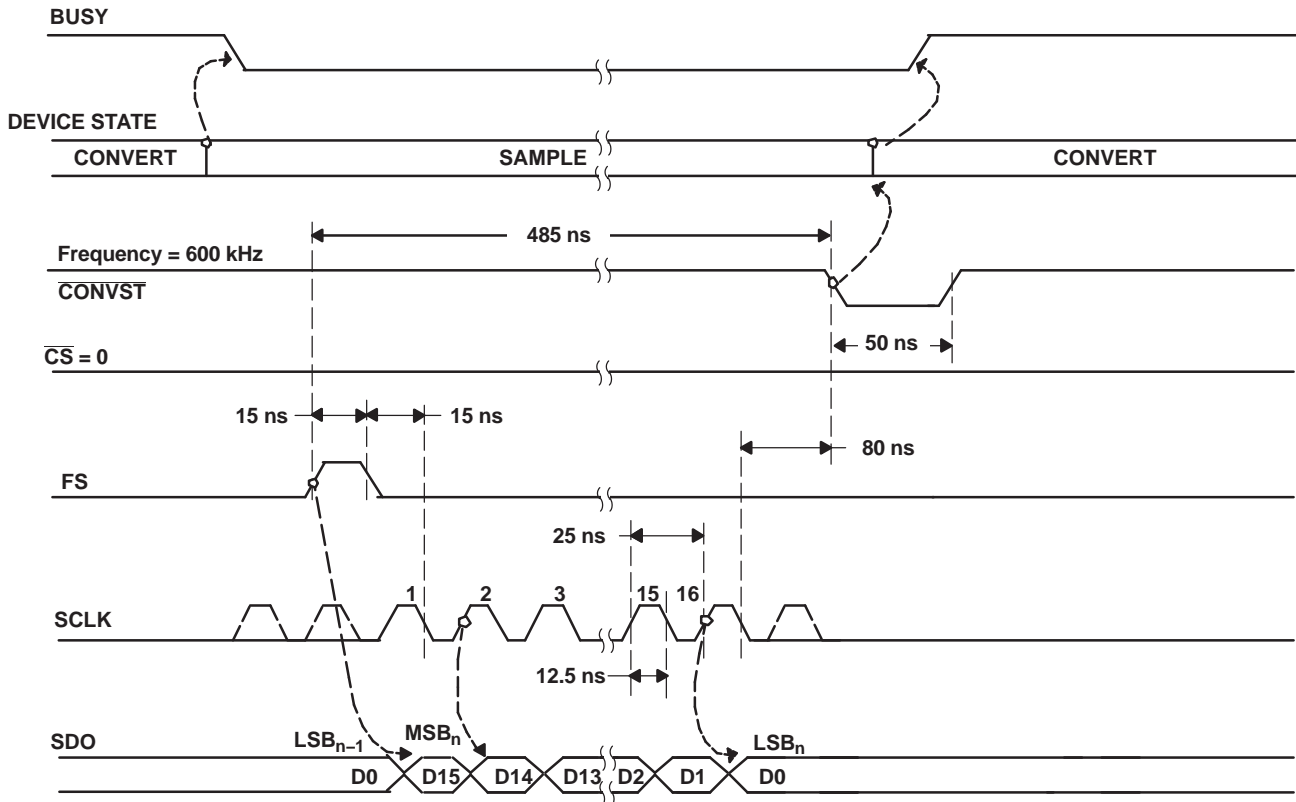

Figure 57. Example Stimulus in Serial Interface With FS Active, Back-To-Back Conversion that Achieves 600 KSPS

PACKAGING INFORMATION

| Orderable Device | Status ⁽¹⁾ | Package Type | Package Drawing | Pins | Package Qty | Eco Plan ⁽²⁾ | Lead/Ball Finish | MSL Peak Temp ⁽³⁾ |
|------------------|-----------------------|--------------|-----------------|------|-------------|-------------------------|------------------|------------------------------|
| ADS8370IBRHPR | ACTIVE | VQFN | RHP | 28 | 2500 | Green (RoHS & no Sb/Br) | CU NIPDAU | Level-2-260C-1 YEAR |
| ADS8370IBRHPRG4 | ACTIVE | VQFN | RHP | 28 | 2500 | Green (RoHS & no Sb/Br) | CU NIPDAU | Level-2-260C-1 YEAR |
| ADS8370IBRHPT | ACTIVE | VQFN | RHP | 28 | 250 | Green (RoHS & no Sb/Br) | CU NIPDAU | Level-2-260C-1 YEAR |
| ADS8370IBRHPTG4 | ACTIVE | VQFN | RHP | 28 | 250 | Green (RoHS & no Sb/Br) | CU NIPDAU | Level-2-260C-1 YEAR |
| ADS8370IRHPR | ACTIVE | VQFN | RHP | 28 | 2500 | Green (RoHS & no Sb/Br) | CU NIPDAU | Level-2-260C-1 YEAR |
| ADS8370IRHPRG4 | ACTIVE | VQFN | RHP | 28 | 2500 | Green (RoHS & no Sb/Br) | CU NIPDAU | Level-2-260C-1 YEAR |
| ADS8370IRHPT | ACTIVE | VQFN | RHP | 28 | 250 | Green (RoHS & no Sb/Br) | CU NIPDAU | Level-2-260C-1 YEAR |
| ADS8370IRHPTG4 | ACTIVE | VQFN | RHP | 28 | 250 | Green (RoHS & no Sb/Br) | CU NIPDAU | Level-2-260C-1 YEAR |

⁽¹⁾ The marketing status values are defined as follows:

ACTIVE: Product device recommended for new designs.

LIFEBUY: TI has announced that the device will be discontinued, and a lifetime-buy period is in effect.

NRND: Not recommended for new designs. Device is in production to support existing customers, but TI does not recommend using this part in a new design.

PREVIEW: Device has been announced but is not in production. Samples may or may not be available.

OBSOLETE: TI has discontinued the production of the device.

⁽²⁾ Eco Plan - The planned eco-friendly classification: Pb-Free (RoHS), Pb-Free (RoHS Exempt), or Green (RoHS & no Sb/Br) - please check <http://www.ti.com/productcontent> for the latest availability information and additional product content details.

TBD: The Pb-Free/Green conversion plan has not been defined.

Pb-Free (RoHS): TI's terms "Lead-Free" or "Pb-Free" mean semiconductor products that are compatible with the current RoHS requirements for all 6 substances, including the requirement that lead not exceed 0.1% by weight in homogeneous materials. Where designed to be soldered at high temperatures, TI Pb-Free products are suitable for use in specified lead-free processes.

Pb-Free (RoHS Exempt): This component has a RoHS exemption for either 1) lead-based flip-chip solder bumps used between the die and package, or 2) lead-based die adhesive used between the die and leadframe. The component is otherwise considered Pb-Free (RoHS compatible) as defined above.

Green (RoHS & no Sb/Br): TI defines "Green" to mean Pb-Free (RoHS compatible), and free of Bromine (Br) and Antimony (Sb) based flame retardants (Br or Sb do not exceed 0.1% by weight in homogeneous material)

⁽³⁾ MSL, Peak Temp. -- The Moisture Sensitivity Level rating according to the JEDEC industry standard classifications, and peak solder temperature.

Important Information and Disclaimer: The information provided on this page represents TI's knowledge and belief as of the date that it is provided. TI bases its knowledge and belief on information provided by third parties, and makes no representation or warranty as to the accuracy of such information. Efforts are underway to better integrate information from third parties. TI has taken and continues to take reasonable steps to provide representative and accurate information but may not have conducted destructive testing or chemical analysis on incoming materials and chemicals. TI and TI suppliers consider certain information to be proprietary, and thus CAS numbers and other limited information may not be available for release.

In no event shall TI's liability arising out of such information exceed the total purchase price of the TI part(s) at issue in this document sold by TI to Customer on an annual basis.

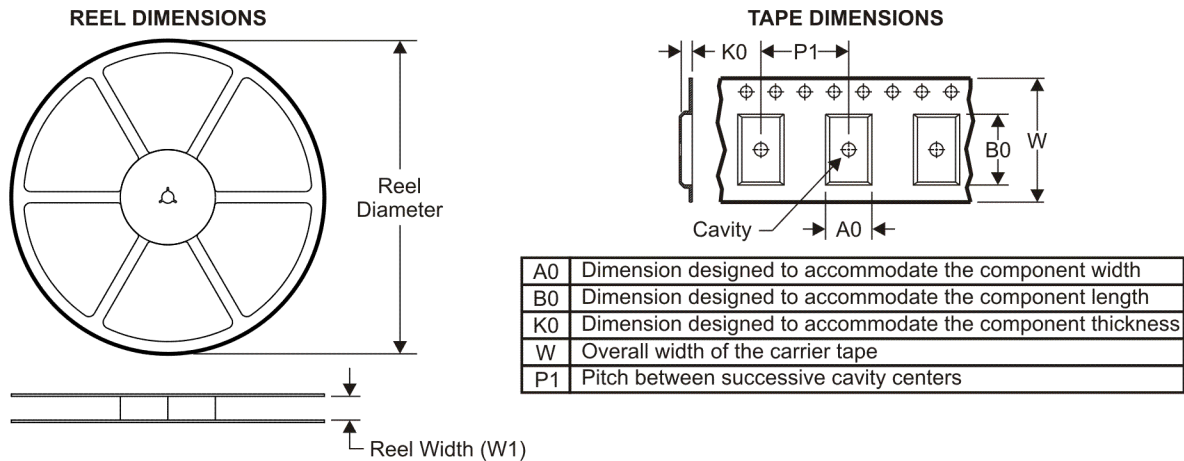
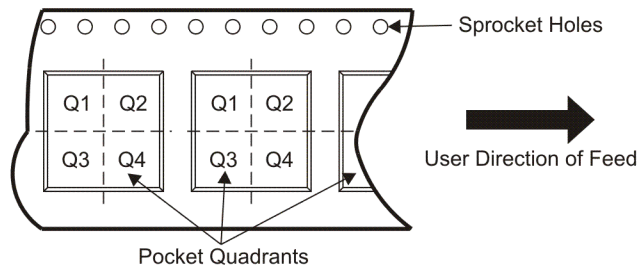
TAPE AND REEL INFORMATION

QUADRANT ASSIGNMENTS FOR PIN 1 ORIENTATION IN TAPE

*All dimensions are nominal

| Device | Package Type | Package Drawing | Pins | SPQ | Reel Diameter (mm) | Reel Width W1 (mm) | A0 (mm) | B0 (mm) | K0 (mm) | P1 (mm) | W (mm) | Pin1 Quadrant |
|---------------|--------------|-----------------|------|------|--------------------|--------------------|---------|---------|---------|---------|--------|---------------|
| ADS8370IBRHPR | VQFN | RHP | 28 | 2500 | 330.0 | 16.4 | 6.3 | 6.3 | 1.5 | 12.0 | 16.0 | Q2 |
| ADS8370IBRHPT | VQFN | RHP | 28 | 250 | 330.0 | 16.4 | 6.3 | 6.3 | 1.5 | 12.0 | 16.0 | Q2 |
| ADS8370IRHPR | VQFN | RHP | 28 | 2500 | 330.0 | 16.4 | 6.3 | 6.3 | 1.5 | 12.0 | 16.0 | Q2 |
| ADS8370IRHPT | VQFN | RHP | 28 | 250 | 330.0 | 16.4 | 6.3 | 6.3 | 1.5 | 12.0 | 16.0 | Q2 |

TAPE AND REEL BOX DIMENSIONS



*All dimensions are nominal

| Device | Package Type | Package Drawing | Pins | SPQ | Length (mm) | Width (mm) | Height (mm) |
|---------------|--------------|-----------------|------|------|-------------|------------|-------------|
| ADS8370IBRHPR | VQFN | RHP | 28 | 2500 | 333.2 | 345.9 | 28.6 |
| ADS8370IBRHPT | VQFN | RHP | 28 | 250 | 333.2 | 345.9 | 28.6 |
| ADS8370IRHPR | VQFN | RHP | 28 | 2500 | 333.2 | 345.9 | 28.6 |
| ADS8370IRHPT | VQFN | RHP | 28 | 250 | 333.2 | 345.9 | 28.6 |

MECHANICAL DATA

RHP (S-PVQFN-N28)

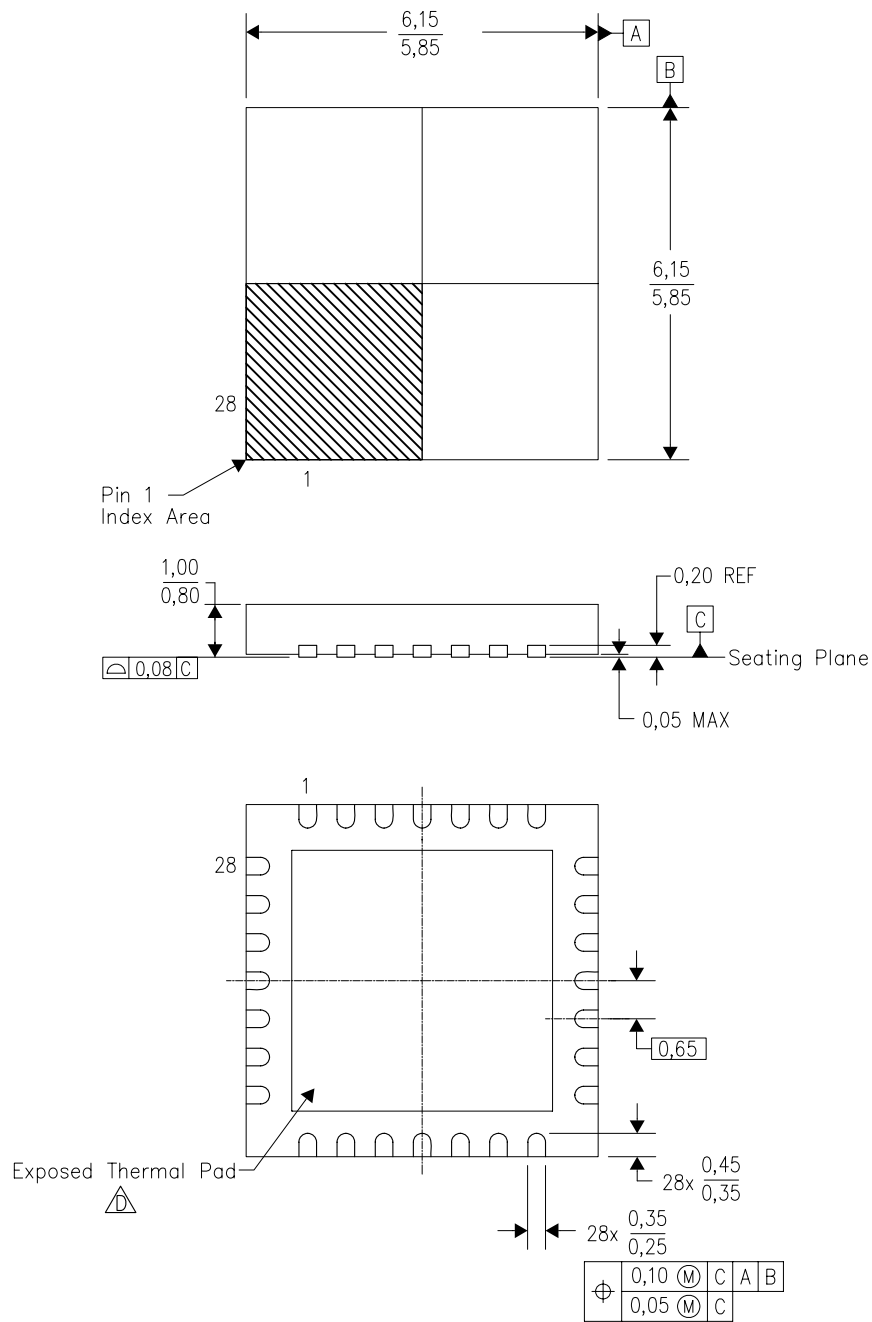
PLASTIC QUAD FLATPACK NO-LEAD



4205387/C 01/11

- NOTES:
- A. All linear dimensions are in millimeters. Dimensioning and tolerancing per ASME Y14.5M-1994.
 - B. This drawing is subject to change without notice.
 - C. QFN (Quad Flatpack No-Lead) Package configuration.
 -  D. The package thermal pad must be soldered to the board for thermal and mechanical performance. See the Product Data Sheet for details regarding the exposed thermal pad dimensions.

THERMAL PAD MECHANICAL DATA

RHP (S-PVQFN-N28)

PLASTIC QUAD FLATPACK NO-LEAD

THERMAL INFORMATION

This package incorporates an exposed thermal pad that is designed to be attached directly to an external heatsink. The thermal pad must be soldered directly to the printed circuit board (PCB). After soldering, the PCB can be used as a heatsink. In addition, through the use of thermal vias, the thermal pad can be attached directly to the appropriate copper plane shown in the electrical schematic for the device, or alternatively, can be attached to a special heatsink structure designed into the PCB. This design optimizes the heat transfer from the integrated circuit (IC).

For information on the Quad Flatpack No-Lead (QFN) package and its advantages, refer to Application Report, QFN/SON PCB Attachment, Texas Instruments Literature No. SLUA271. This document is available at www.ti.com.

The exposed thermal pad dimensions for this package are shown in the following illustration.

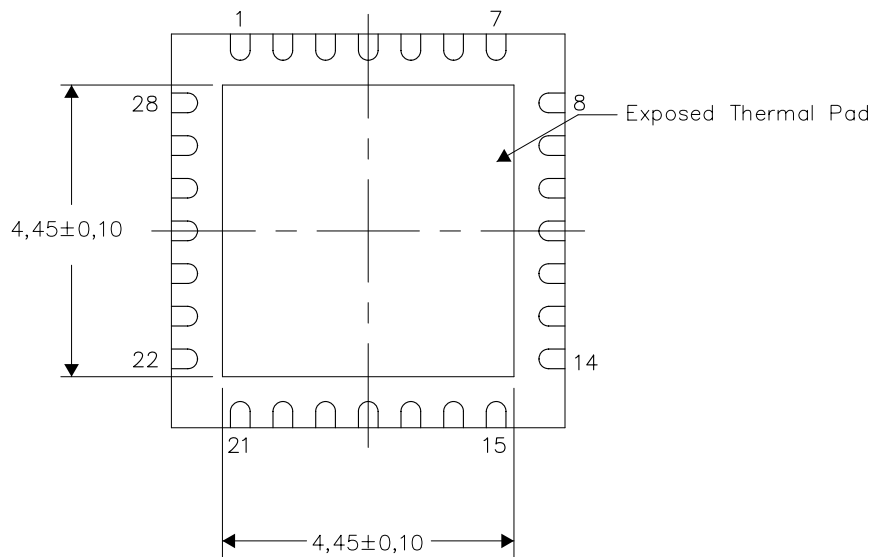

Exposed Thermal Pad Dimensions

4206484/E 01/11

NOTE: All linear dimensions are in millimeters

RHP (S-PVQFN-N28)

PLASTIC QUAD FLATPACK NO-LEAD

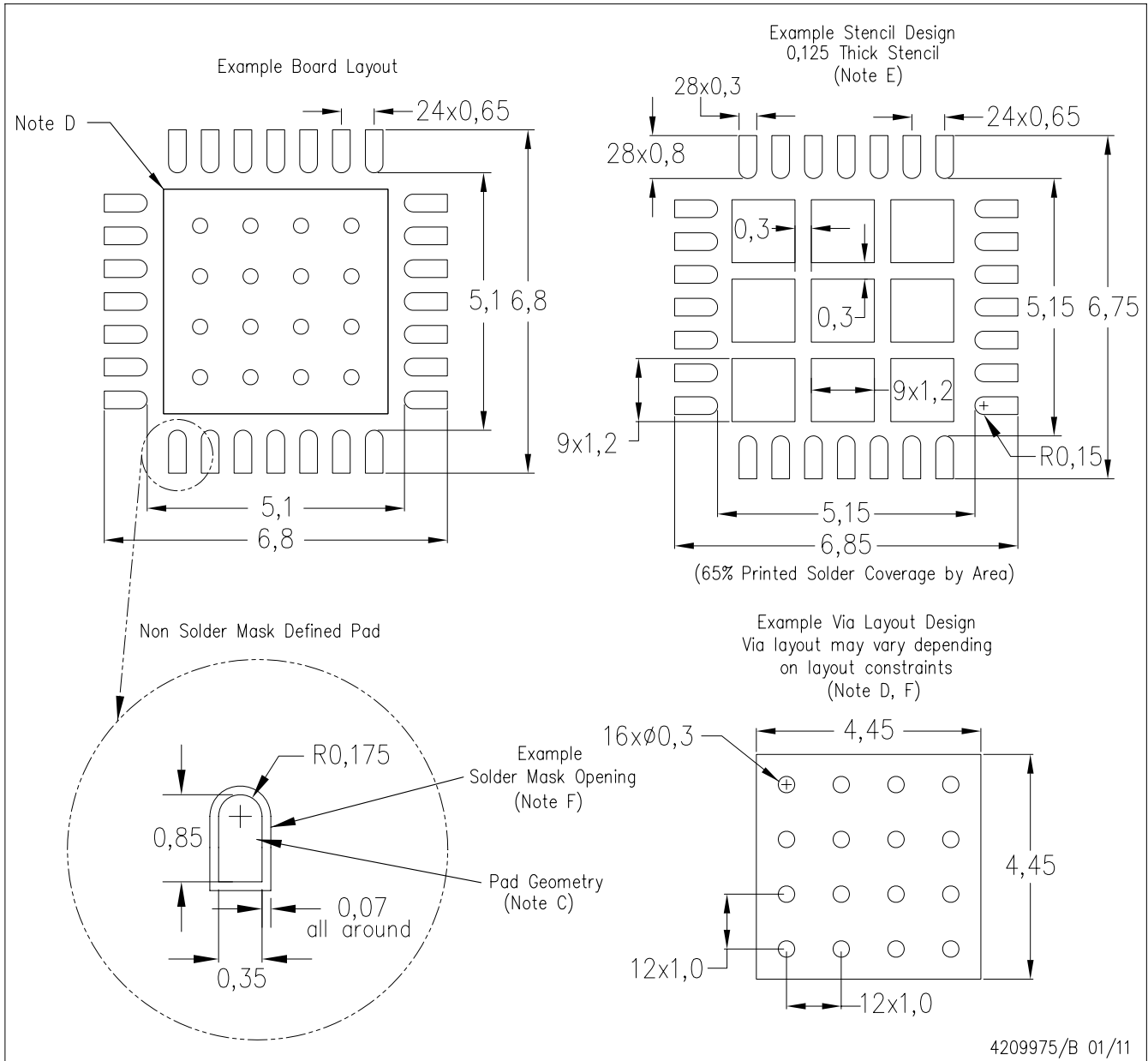

- NOTES:
- A. All linear dimensions are in millimeters.
 - B. This drawing is subject to change without notice.
 - C. Publication IPC-7351 is recommended for alternate designs.
 - D. This package is designed to be soldered to a thermal pad on the board. Refer to Application Note, Quad Flat-Pack Packages, Texas Instruments Literature No. SLUA271, and also the Product Data Sheets for specific thermal information, via requirements, and recommended board layout. These documents are available at www.ti.com <<http://www.ti.com>>.
 - E. Laser cutting apertures with trapezoidal walls and also rounding corners will offer better paste release. Customers should contact their board assembly site for stencil design recommendations. Refer to IPC 7525 for stencil design considerations.
 - F. Customers should contact their board fabrication site for recommended solder mask tolerances and via tenting recommendations for vias placed in the thermal pad.

IMPORTANT NOTICE

Texas Instruments Incorporated and its subsidiaries (TI) reserve the right to make corrections, modifications, enhancements, improvements, and other changes to its products and services at any time and to discontinue any product or service without notice. Customers should obtain the latest relevant information before placing orders and should verify that such information is current and complete. All products are sold subject to TI's terms and conditions of sale supplied at the time of order acknowledgment.

TI warrants performance of its hardware products to the specifications applicable at the time of sale in accordance with TI's standard warranty. Testing and other quality control techniques are used to the extent TI deems necessary to support this warranty. Except where mandated by government requirements, testing of all parameters of each product is not necessarily performed.

TI assumes no liability for applications assistance or customer product design. Customers are responsible for their products and applications using TI components. To minimize the risks associated with customer products and applications, customers should provide adequate design and operating safeguards.

TI does not warrant or represent that any license, either express or implied, is granted under any TI patent right, copyright, mask work right, or other TI intellectual property right relating to any combination, machine, or process in which TI products or services are used. Information published by TI regarding third-party products or services does not constitute a license from TI to use such products or services or a warranty or endorsement thereof. Use of such information may require a license from a third party under the patents or other intellectual property of the third party, or a license from TI under the patents or other intellectual property of TI.

Reproduction of TI information in TI data books or data sheets is permissible only if reproduction is without alteration and is accompanied by all associated warranties, conditions, limitations, and notices. Reproduction of this information with alteration is an unfair and deceptive business practice. TI is not responsible or liable for such altered documentation. Information of third parties may be subject to additional restrictions.

Resale of TI products or services with statements different from or beyond the parameters stated by TI for that product or service voids all express and any implied warranties for the associated TI product or service and is an unfair and deceptive business practice. TI is not responsible or liable for any such statements.

TI products are not authorized for use in safety-critical applications (such as life support) where a failure of the TI product would reasonably be expected to cause severe personal injury or death, unless officers of the parties have executed an agreement specifically governing such use. Buyers represent that they have all necessary expertise in the safety and regulatory ramifications of their applications, and acknowledge and agree that they are solely responsible for all legal, regulatory and safety-related requirements concerning their products and any use of TI products in such safety-critical applications, notwithstanding any applications-related information or support that may be provided by TI. Further, Buyers must fully indemnify TI and its representatives against any damages arising out of the use of TI products in such safety-critical applications.

TI products are neither designed nor intended for use in military/aerospace applications or environments unless the TI products are specifically designated by TI as military-grade or "enhanced plastic." Only products designated by TI as military-grade meet military specifications. Buyers acknowledge and agree that any such use of TI products which TI has not designated as military-grade is solely at the Buyer's risk, and that they are solely responsible for compliance with all legal and regulatory requirements in connection with such use.

TI products are neither designed nor intended for use in automotive applications or environments unless the specific TI products are designated by TI as compliant with ISO/TS 16949 requirements. Buyers acknowledge and agree that, if they use any non-designated products in automotive applications, TI will not be responsible for any failure to meet such requirements.

Following are URLs where you can obtain information on other Texas Instruments products and application solutions:

Products

| | |
|-----------------------------|--|
| Audio | www.ti.com/audio |
| Amplifiers | amplifier.ti.com |
| Data Converters | dataconverter.ti.com |
| DLP® Products | www.dlp.com |
| DSP | dsp.ti.com |
| Clocks and Timers | www.ti.com/clocks |
| Interface | interface.ti.com |
| Logic | logic.ti.com |
| Power Mgmt | power.ti.com |
| Microcontrollers | microcontroller.ti.com |
| RFID | www.ti-rfid.com |
| RF/IF and ZigBee® Solutions | www.ti.com/lprf |

Applications

| | |
|-------------------------------|--|
| Communications and Telecom | www.ti.com/communications |
| Computers and Peripherals | www.ti.com/computers |
| Consumer Electronics | www.ti.com/consumer-apps |
| Energy and Lighting | www.ti.com/energy |
| Industrial | www.ti.com/industrial |
| Medical | www.ti.com/medical |
| Security | www.ti.com/security |
| Space, Avionics and Defense | www.ti.com/space-avionics-defense |
| Transportation and Automotive | www.ti.com/automotive |
| Video and Imaging | www.ti.com/video |
| Wireless | www.ti.com/wireless-apps |

TI E2E Community Home Page

e2e.ti.com

Mailing Address: Texas Instruments, Post Office Box 655303, Dallas, Texas 75265
Copyright © 2011, Texas Instruments Incorporated