

# CY74FCT2257T QUAD 2-INPUT MULTIPLEXER WITH 3-STATE OUTPUTS

SCCS038B – SEPTEMBER 1994 – REVISED OCTOBER 2001

- Function and Pinout Compatible With FCT and F Logic
- 25- $\Omega$  Output Series Resistors to Reduce Transmission-Line Reflection Noise
- TTL Output Level Versions of Equivalent FCT Functions
- Edge-Rate Control Circuitry for Significantly Improved Noise Characteristics
- $I_{off}$  Supports Partial-Power-Down Mode Operation
- Fully Compatible With TTL Input and Output Logic Levels
- ESD Protection Exceeds JESD 22
  - 2000-V Human-Body Model (A114-A)
  - 200-V Machine Model (A115-A)
  - 1000-V Charged-Device Model (C101)
- 12-mA Output Sink Current  
15-mA Output Source Current
- 3-State Outputs

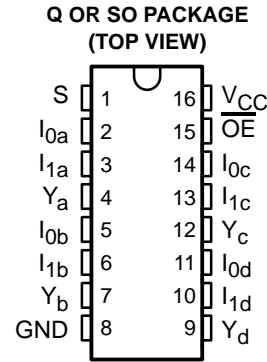

## description

The CY74FCT2257T has four identical two-input multiplexers that select four bits of data from two sources under the control of a common data-select (S) input. The  $I_0$  inputs are selected when S is low, and the  $I_1$  inputs are selected when S is high. Data appears at the output in noninverted form for the CY74FCT2257T. On-chip termination resistors at the outputs reduce system noise caused by reflections. The CY74FCT2257T can replace the FCT257T to reduce noise in an existing design.

The CY74FCT2257T is a logic implementation of a four-pole, two-position switch, in which the position of the switch is determined by the logic levels supplied to S. Outputs are forced to the high-impedance off state when the output-enable ( $\overline{OE}$ ) input is high.

All but one device must be in the high-impedance state to prevent currents from exceeding the maximum ratings if outputs are tied together. Design of the  $\overline{OE}$  signals must ensure that there is no overlap when outputs of 3-state devices are tied together.

This device is fully specified for partial-power-down applications using  $I_{off}$ . The  $I_{off}$  circuitry disables the outputs, preventing damaging current backflow through the device when it is powered down.

### PIN DESCRIPTION

| NAME            | DESCRIPTION                      |
|-----------------|----------------------------------|
| I               | Data inputs                      |
| S               | Common data-select input         |
| $\overline{OE}$ | Output-enable input (active low) |
| Y               | Data outputs                     |



Please be aware that an important notice concerning availability, standard warranty, and use in critical applications of Texas Instruments semiconductor products and disclaimers thereto appears at the end of this data sheet.

PRODUCTION DATA information is current as of publication date. Products conform to specifications per the terms of Texas Instruments standard warranty. Production processing does not necessarily include testing of all parameters.

 **TEXAS  
INSTRUMENTS**

POST OFFICE BOX 655303 • DALLAS, TEXAS 75265

Copyright © 2001, Texas Instruments Incorporated

# CY74FCT2257T QUAD 2-INPUT MULTIPLEXER WITH 3-STATE OUTPUTS

SCCS038B – SEPTEMBER 1994 – REVISED OCTOBER 2001

## ORDERING INFORMATION

| T <sub>A</sub> | PACKAGE†  |               | SPEED (ns) | ORDERABLE PART NUMBER | TOP-SIDE MARKING |
|----------------|-----------|---------------|------------|-----------------------|------------------|
| -40°C to 85°C  | QSOP – Q  | Tape and reel | 4.3        | CY74FCT2257CTQCT      | FR257-3          |
|                | SOIC – SO | Tube          | 4.3        | CY74FCT2257CTSOC      | FCT2257C         |
|                |           | Tape and reel | 4.3        | CY74FCT2257CTSOCT     |                  |
|                | QSOP – Q  | Tape and reel | 5          | CY74FCT2257ATQCT      | FR257-1          |

† Package drawings, standard packing quantities, thermal data, symbolization, and PCB design guidelines are available at [www.ti.com/sc/package](http://www.ti.com/sc/package).

## FUNCTION TABLE

| $\overline{OE}$ | INPUTS |                |                | OUTPUT |
|-----------------|--------|----------------|----------------|--------|
|                 | S      | I <sub>0</sub> | I <sub>1</sub> | Y      |
| H               | X      | X              | X              | Z      |
| L               | H      | X              | L              | L      |
| L               | H      | X              | H              | H      |
| L               | L      | L              | X              | L      |
| L               | L      | H              | X              | H      |

H = High logic level, L = Low logic level, X = Don't care, Z = High-impedance (off) state

## logic diagram (positive logic)



**CY74FCT2257T**  
**QUAD 2-INPUT MULTIPLEXER**  
**WITH 3-STATE OUTPUTS**

SCCS038B – SEPTEMBER 1994 – REVISED OCTOBER 2001

**absolute maximum rating over operating free-air temperature range (unless otherwise noted)†**

|                                                                        |                |
|------------------------------------------------------------------------|----------------|
| Supply voltage range to ground potential .....                         | –0.5 V to 7 V  |
| DC input voltage range .....                                           | –0.5 V to 7 V  |
| DC output voltage range .....                                          | –0.5 V to 7 V  |
| DC output current (maximum sink current/pin) .....                     | 120 mA         |
| Package thermal impedance, $\theta_{JA}$ (see Note 1): Q package ..... | 90°C/W         |
| SO package .....                                                       | 57°C/W         |
| Ambient temperature range with power applied, $T_A$ .....              | –65°C to 135°C |
| Storage temperature range, $T_{Stg}$ .....                             | –65°C to 150°C |

† Stresses beyond those listed under “absolute maximum ratings” may cause permanent damage to the device. These are stress ratings only, and functional operation of the device at these or any other conditions beyond those indicated under “recommended operating conditions” is not implied. Exposure to absolute-maximum-rated conditions for extended periods may affect device reliability.

NOTES: 1. The package thermal impedance is calculated in accordance with JESD 51-7.

**recommended operating conditions (see Note 2)**

|                                      | MIN  | NOM | MAX  | UNIT |
|--------------------------------------|------|-----|------|------|
| $V_{CC}$ Supply voltage              | 4.75 | 5   | 5.25 | V    |
| $V_{IH}$ High-level input voltage    | 2    |     |      | V    |
| $V_{IL}$ Low-level input voltage     |      |     | 0.8  | V    |
| $I_{OH}$ High-level output current   |      |     | –15  | mA   |
| $I_{OL}$ Low-level output current    |      |     | 12   | mA   |
| $T_A$ Operating free-air temperature | –40  |     | 85   | °C   |

NOTE 2: All unused inputs of the device must be held at  $V_{CC}$  or GND to ensure proper device operation.



# CY74FCT2257T

## QUAD 2-INPUT MULTIPLEXER

### WITH 3-STATE OUTPUTS

SCCS038B – SEPTEMBER 1994 – REVISED OCTOBER 2001

electrical characteristics over recommended operating free-air temperature range (unless otherwise noted)

| PARAMETER          | TEST CONDITIONS                                                                                                                                               |                                                                         | MIN                                                                     | TYP† | MAX  | UNIT   |
|--------------------|---------------------------------------------------------------------------------------------------------------------------------------------------------------|-------------------------------------------------------------------------|-------------------------------------------------------------------------|------|------|--------|
| V <sub>IK</sub>    | V <sub>CC</sub> = 4.75 V,                                                                                                                                     | I <sub>IN</sub> = -18 mA                                                |                                                                         | -0.7 | -1.2 | V      |
| V <sub>OH</sub>    | V <sub>CC</sub> = 4.75 V,                                                                                                                                     | I <sub>OH</sub> = -15 mA                                                | 2.4                                                                     | 3.3  |      | V      |
| V <sub>OL</sub>    | V <sub>CC</sub> = 4.75 V,                                                                                                                                     | I <sub>OL</sub> = 12 mA                                                 |                                                                         | 0.3  | 0.55 | V      |
| R <sub>out</sub>   | V <sub>CC</sub> = 4.75 V,                                                                                                                                     | I <sub>OL</sub> = 12 mA                                                 | 20                                                                      | 25   | 40   | Ω      |
| V <sub>hys</sub>   | All inputs                                                                                                                                                    |                                                                         |                                                                         | 0.2  |      | V      |
| I <sub>IH</sub>    | V <sub>CC</sub> = 5.25 V,                                                                                                                                     | V <sub>IN</sub> = 2.7 V                                                 |                                                                         |      | ±1   | μA     |
| I <sub>IL</sub>    | V <sub>CC</sub> = 5.25 V,                                                                                                                                     | V <sub>IN</sub> = 0.5 V                                                 |                                                                         |      | ±1   | μA     |
| I <sub>OZH</sub>   | V <sub>CC</sub> = 5.25 V,                                                                                                                                     | V <sub>OUT</sub> = 2.7 V                                                |                                                                         |      | 10   | μA     |
| I <sub>OZL</sub>   | V <sub>CC</sub> = 5.25 V,                                                                                                                                     | V <sub>OUT</sub> = 0.5 V                                                |                                                                         |      | -10  | μA     |
| I <sub>OS</sub> ‡  | V <sub>CC</sub> = 5.25 V,                                                                                                                                     | V <sub>OUT</sub> = 0 V                                                  | -60                                                                     | -120 | -225 | mA     |
| I <sub>off</sub>   | V <sub>CC</sub> = 0 V,                                                                                                                                        | V <sub>OUT</sub> = 4.5 V                                                |                                                                         |      | ±1   | μA     |
| I <sub>CC</sub>    | V <sub>CC</sub> = 5.25 V,                                                                                                                                     | V <sub>IN</sub> ≤ 0.2 V, V <sub>IN</sub> ≥ V <sub>CC</sub> - 0.2 V      |                                                                         | 0.1  | 0.2  | mA     |
| ΔI <sub>CC</sub>   | V <sub>CC</sub> = 5.25 V, V <sub>IN</sub> = 3.4 V§, f <sub>1</sub> = 0, Outputs open                                                                          |                                                                         |                                                                         | 0.5  | 2    | mA     |
| I <sub>CCD</sub> ¶ | V <sub>CC</sub> = 5.25 V, One input switching at 50% duty cycle, Outputs open, OE = GND, V <sub>IN</sub> ≤ 0.2 V or V <sub>IN</sub> ≥ V <sub>CC</sub> - 0.2 V |                                                                         |                                                                         | 0.06 | 0.12 | mA/MHz |
| I <sub>C</sub> #   | V <sub>CC</sub> = 5.25 V,<br>Outputs open,<br>OE = GND                                                                                                        | One bit switching<br>at f <sub>1</sub> = 10 MHz<br>at 50% duty cycle    | V <sub>IN</sub> ≤ 0.2 V or<br>V <sub>IN</sub> ≥ V <sub>CC</sub> - 0.2 V | 0.7  | 1.4  | mA     |
|                    |                                                                                                                                                               |                                                                         | V <sub>IN</sub> = 3.4 V or GND                                          | 1    | 2.4  |        |
|                    |                                                                                                                                                               | Four bits switching<br>at f <sub>1</sub> = 2.5 MHz<br>at 50% duty cycle | V <sub>IN</sub> ≤ 0.2 V or<br>V <sub>IN</sub> ≥ V <sub>CC</sub> - 0.2 V | 0.7  | 1.4  |        |
|                    |                                                                                                                                                               |                                                                         | V <sub>IN</sub> = 3.4 V or GND                                          | 1.7  | 5.4  |        |
| C <sub>i</sub>     |                                                                                                                                                               |                                                                         |                                                                         | 5    | 10   | pF     |
| C <sub>o</sub>     |                                                                                                                                                               |                                                                         |                                                                         | 9    | 12   | pF     |

† Typical values are at V<sub>CC</sub> = 5 V, T<sub>A</sub> = 25°C.

‡ Not more than one output should be shorted at a time. Duration of short should not exceed one second. The use of high-speed test apparatus and/or sample-and-hold techniques are preferable to minimize internal chip heating and more accurately reflect operational values. Otherwise, prolonged shorting of a high output can raise the chip temperature well above normal and cause invalid readings in other parametric tests. In any sequence of parameter tests, I<sub>OS</sub> tests should be performed last.

§ Per TTL-driven input (V<sub>IN</sub> = 3.4 V); all other inputs at V<sub>CC</sub> or GND

¶ This parameter is derived for use in total power-supply calculations.

# I<sub>C</sub> = I<sub>CC</sub> + ΔI<sub>CC</sub> × D<sub>H</sub> × N<sub>T</sub> + I<sub>CCD</sub> (f<sub>0</sub>/2 + f<sub>1</sub> × N<sub>1</sub>)

Where:

I<sub>C</sub> = Total supply current

I<sub>CC</sub> = Power-supply current with CMOS input levels

ΔI<sub>CC</sub> = Power-supply current for a TTL high input (V<sub>IN</sub> = 3.4 V)

D<sub>H</sub> = Duty cycle for TTL inputs high

N<sub>T</sub> = Number of TTL inputs at D<sub>H</sub>

I<sub>CCD</sub> = Dynamic current caused by an input transition pair (HLH or LHL)

f<sub>0</sub> = Clock frequency for registered devices, otherwise zero

f<sub>1</sub> = Input signal frequency

N<sub>1</sub> = Number of inputs changing at f<sub>1</sub>

All currents are in milliamperes and all frequencies are in megahertz.

|| Values for these conditions are examples of the I<sub>C</sub> formula.



**CY74FCT2257T**  
**QUAD 2-INPUT MULTIPLEXER**  
**WITH 3-STATE OUTPUTS**

SCCS038B – SEPTEMBER 1994 – REVISED OCTOBER 2001

switching characteristics over operating free-air temperature range (see Figure 1)

| PARAMETER        | FROM<br>(INPUT)                  | TO<br>(OUTPUT) | CY74FCT2257AT |     | CY74FCT2257CT |     | UNIT |
|------------------|----------------------------------|----------------|---------------|-----|---------------|-----|------|
|                  |                                  |                | MIN           | MAX | MIN           | MAX |      |
| t <sub>PLH</sub> | I <sub>a</sub> or I <sub>b</sub> | Y              | 1.5           | 5   | 1.5           | 4.7 | ns   |
| t <sub>PHL</sub> |                                  |                | 1.5           | 5   | 1.5           | 4.7 |      |
| t <sub>PLH</sub> | S                                | Y              | 1.5           | 7   | 1.5           | 5.2 | ns   |
| t <sub>PHL</sub> |                                  |                | 1.5           | 7   | 1.5           | 5.2 |      |
| t <sub>PZH</sub> | $\overline{OE}$                  | Y              | 1.5           | 7   | 1.5           | 6   | ns   |
| t <sub>PZL</sub> |                                  |                | 1.5           | 7   | 1.5           | 6   |      |
| t <sub>PHZ</sub> | $\overline{OE}$                  | Y              | 1.5           | 5.5 | 1.5           | 5   | ns   |
| t <sub>PLZ</sub> |                                  |                | 1.5           | 5.5 | 1.5           | 5   |      |

**CY74FCT2257T**  
**QUAD 2-INPUT MULTIPLEXER**  
**WITH 3-STATE OUTPUTS**

SCCS038B – SEPTEMBER 1994 – REVISED OCTOBER 2001

**PARAMETER MEASUREMENT INFORMATION**

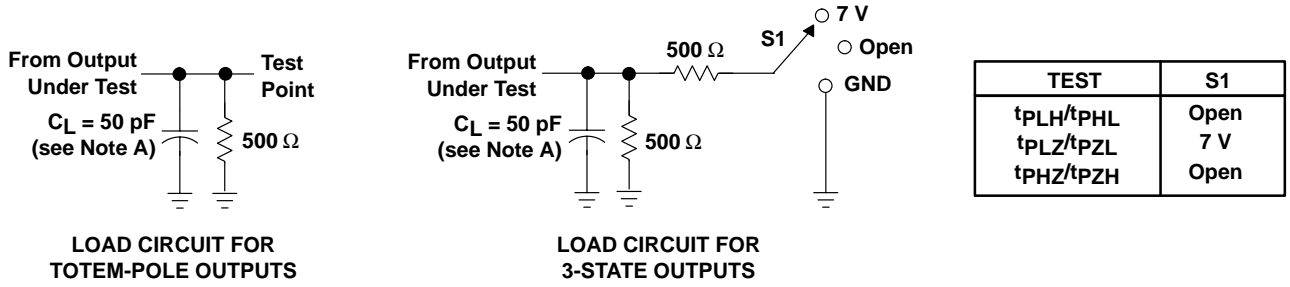

**LOAD CIRCUIT FOR TOTEM-POLE OUTPUTS**

**LOAD CIRCUIT FOR 3-STATE OUTPUTS**

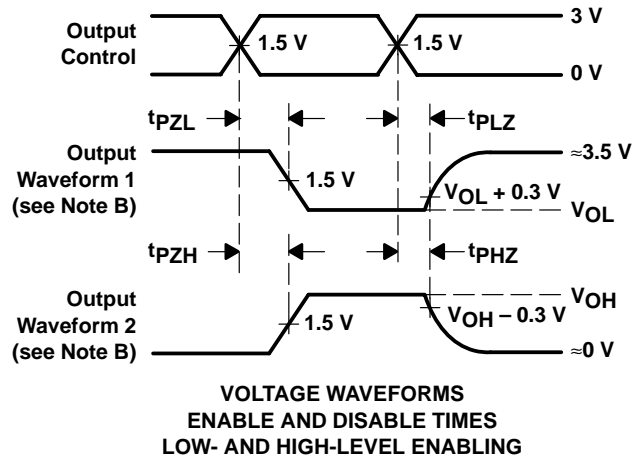
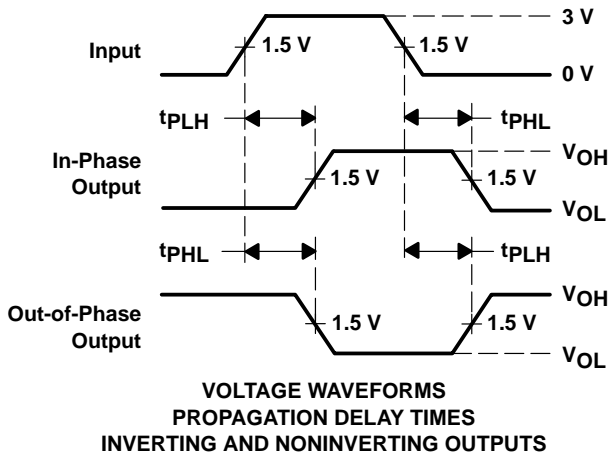
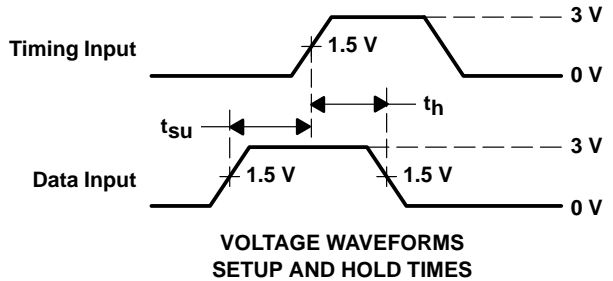
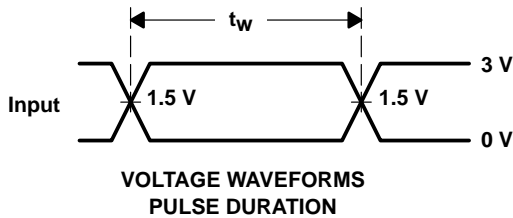

- NOTES: A.  $C_L$  includes probe and jig capacitance.  
 B. Waveform 1 is for an output with internal conditions such that the output is low except when disabled by the output control. Waveform 2 is for an output with internal conditions such that the output is high except when disabled by the output control.  
 C. The outputs are measured one at a time with one input transition per measurement.

**Figure 1. Load Circuit and Voltage Waveforms**

**PACKAGING INFORMATION**

| Orderable Device   | Status <sup>(1)</sup> | Package Type  | Package Drawing | Pins | Package Qty | Eco Plan <sup>(2)</sup> | Lead/Ball Finish | MSL Peak Temp <sup>(3)</sup> |
|--------------------|-----------------------|---------------|-----------------|------|-------------|-------------------------|------------------|------------------------------|
| 74FCT2257CTSOCTE4  | ACTIVE                | SOIC          | DW              | 16   | 2000        | Green (RoHS & no Sb/Br) | CU NIPDAU        | Level-1-260C-UNLIM           |
| 74FCT2257CTSOCTG4  | ACTIVE                | SOIC          | DW              | 16   | 2000        | Green (RoHS & no Sb/Br) | CU NIPDAU        | Level-1-260C-UNLIM           |
| CY74FCT2257ATQCT   | ACTIVE                | SSOP/<br>QSOP | DBQ             | 16   | 2500        | Green (RoHS & no Sb/Br) | CU NIPDAU        | Level-2-260C-1 YEAR          |
| CY74FCT2257ATQCTE4 | ACTIVE                | SSOP/<br>QSOP | DBQ             | 16   | 2500        | Green (RoHS & no Sb/Br) | CU NIPDAU        | Level-2-260C-1 YEAR          |
| CY74FCT2257ATQCTG4 | ACTIVE                | SSOP/<br>QSOP | DBQ             | 16   | 2500        | Green (RoHS & no Sb/Br) | CU NIPDAU        | Level-2-260C-1 YEAR          |
| CY74FCT2257CTQCT   | ACTIVE                | SSOP/<br>QSOP | DBQ             | 16   | 2500        | Green (RoHS & no Sb/Br) | CU NIPDAU        | Level-2-260C-1 YEAR          |
| CY74FCT2257CTQCTE4 | ACTIVE                | SSOP/<br>QSOP | DBQ             | 16   | 2500        | Green (RoHS & no Sb/Br) | CU NIPDAU        | Level-2-260C-1 YEAR          |
| CY74FCT2257CTQCTG4 | ACTIVE                | SSOP/<br>QSOP | DBQ             | 16   | 2500        | Green (RoHS & no Sb/Br) | CU NIPDAU        | Level-2-260C-1 YEAR          |
| CY74FCT2257CTSOC   | ACTIVE                | SOIC          | DW              | 16   | 40          | Green (RoHS & no Sb/Br) | CU NIPDAU        | Level-1-260C-UNLIM           |
| CY74FCT2257CTSOCE4 | ACTIVE                | SOIC          | DW              | 16   | 40          | Green (RoHS & no Sb/Br) | CU NIPDAU        | Level-1-260C-UNLIM           |
| CY74FCT2257CTSOCG4 | ACTIVE                | SOIC          | DW              | 16   | 40          | Green (RoHS & no Sb/Br) | CU NIPDAU        | Level-1-260C-UNLIM           |
| CY74FCT2257CTSOCT  | ACTIVE                | SOIC          | DW              | 16   | 2000        | Green (RoHS & no Sb/Br) | CU NIPDAU        | Level-1-260C-UNLIM           |

<sup>(1)</sup> The marketing status values are defined as follows:

**ACTIVE:** Product device recommended for new designs.

**LIFEBUY:** TI has announced that the device will be discontinued, and a lifetime-buy period is in effect.

**NRND:** Not recommended for new designs. Device is in production to support existing customers, but TI does not recommend using this part in a new design.

**PREVIEW:** Device has been announced but is not in production. Samples may or may not be available.

**OBSOLETE:** TI has discontinued the production of the device.

<sup>(2)</sup> Eco Plan - The planned eco-friendly classification: Pb-Free (RoHS), Pb-Free (RoHS Exempt), or Green (RoHS & no Sb/Br) - please check <http://www.ti.com/productcontent> for the latest availability information and additional product content details.

**TBD:** The Pb-Free/Green conversion plan has not been defined.

**Pb-Free (RoHS):** TI's terms "Lead-Free" or "Pb-Free" mean semiconductor products that are compatible with the current RoHS requirements for all 6 substances, including the requirement that lead not exceed 0.1% by weight in homogeneous materials. Where designed to be soldered at high temperatures, TI Pb-Free products are suitable for use in specified lead-free processes.

**Pb-Free (RoHS Exempt):** This component has a RoHS exemption for either 1) lead-based flip-chip solder bumps used between the die and package, or 2) lead-based die adhesive used between the die and leadframe. The component is otherwise considered Pb-Free (RoHS compatible) as defined above.

**Green (RoHS & no Sb/Br):** TI defines "Green" to mean Pb-Free (RoHS compatible), and free of Bromine (Br) and Antimony (Sb) based flame retardants (Br or Sb do not exceed 0.1% by weight in homogeneous material)

<sup>(3)</sup> MSL, Peak Temp. -- The Moisture Sensitivity Level rating according to the JEDEC industry standard classifications, and peak solder temperature.

**Important Information and Disclaimer:** The information provided on this page represents TI's knowledge and belief as of the date that it is provided. TI bases its knowledge and belief on information provided by third parties, and makes no representation or warranty as to the accuracy of such information. Efforts are underway to better integrate information from third parties. TI has taken and continues to take reasonable steps to provide representative and accurate information but may not have conducted destructive testing or chemical analysis on incoming materials and chemicals. TI and TI suppliers consider certain information to be proprietary, and thus CAS numbers and other limited information may not be available for release.

In no event shall TI's liability arising out of such information exceed the total purchase price of the TI part(s) at issue in this document sold by TI to Customer on an annual basis.

**TAPE AND REEL BOX INFORMATION**

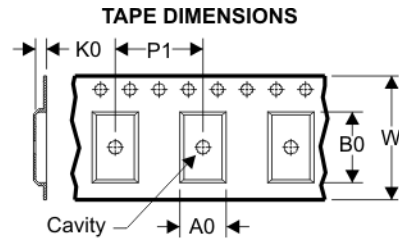
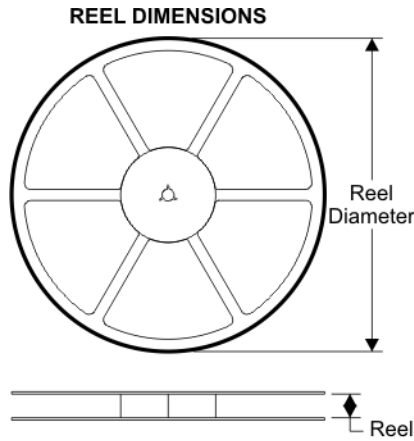

|    |                                                           |
|----|-----------------------------------------------------------|
| A0 | Dimension designed to accommodate the component width     |
| B0 | Dimension designed to accommodate the component length    |
| K0 | Dimension designed to accommodate the component thickness |
| W  | Overall width of the carrier tape                         |
| P1 | Pitch between successive cavity centers                   |

**QUADRANT ASSIGNMENTS FOR PIN 1 ORIENTATION IN TAPE**

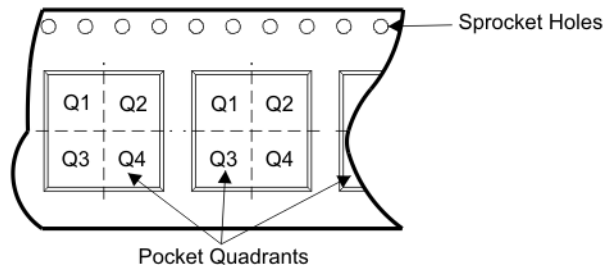

| Device            | Package | Pins | Site    | Reel Diameter (mm) | Reel Width (mm) | A0 (mm) | B0 (mm) | K0 (mm) | P1 (mm) | W (mm) | Pin1 Quadrant |
|-------------------|---------|------|---------|--------------------|-----------------|---------|---------|---------|---------|--------|---------------|
| CY74FCT2257ATQCT  | DBQ     | 16   | SITE 27 | 330                | 0               | 6.4     | 5.2     | 2.1     | 8       | 12     | Q1            |
| CY74FCT2257CTQCT  | DBQ     | 16   | SITE 27 | 330                | 0               | 6.4     | 5.2     | 2.1     | 8       | 12     | Q1            |
| CY74FCT2257CTSOCT | DW      | 16   | SITE 60 | 330                | 16              | 10.75   | 10.7    | 2.7     | 12      | 16     | Q1            |

**TAPE AND REEL BOX DIMENSIONS**



| Device            | Package | Pins | Site    | Length (mm) | Width (mm) | Height (mm) |
|-------------------|---------|------|---------|-------------|------------|-------------|
| CY74FCT2257ATQCT  | DBQ     | 16   | SITE 27 | 342.9       | 336.6      | 20.64       |
| CY74FCT2257CTQCT  | DBQ     | 16   | SITE 27 | 342.9       | 336.6      | 20.64       |
| CY74FCT2257CTSOCT | DW      | 16   | SITE 60 | 346.0       | 346.0      | 33.0        |

DW (R-PDSO-G16)

PLASTIC SMALL-OUTLINE PACKAGE

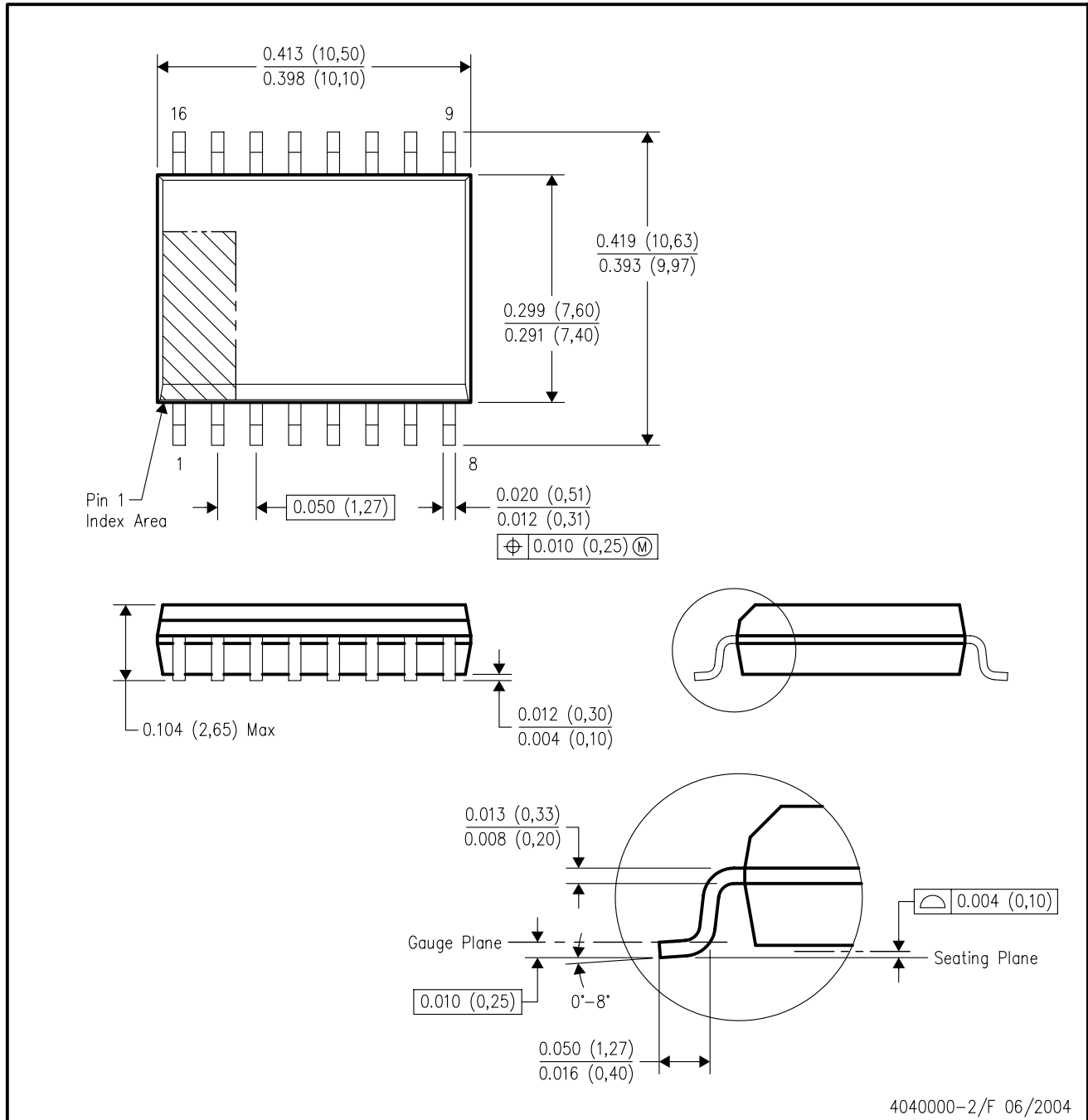

- NOTES:
- A. All linear dimensions are in inches (millimeters).
  - B. This drawing is subject to change without notice.
  - C. Body dimensions do not include mold flash or protrusion not to exceed 0.006 (0,15).
  - D. Falls within JEDEC MS-013 variation AA.



## IMPORTANT NOTICE

Texas Instruments Incorporated and its subsidiaries (TI) reserve the right to make corrections, modifications, enhancements, improvements, and other changes to its products and services at any time and to discontinue any product or service without notice. Customers should obtain the latest relevant information before placing orders and should verify that such information is current and complete. All products are sold subject to TI's terms and conditions of sale supplied at the time of order acknowledgment.

TI warrants performance of its hardware products to the specifications applicable at the time of sale in accordance with TI's standard warranty. Testing and other quality control techniques are used to the extent TI deems necessary to support this warranty. Except where mandated by government requirements, testing of all parameters of each product is not necessarily performed.

TI assumes no liability for applications assistance or customer product design. Customers are responsible for their products and applications using TI components. To minimize the risks associated with customer products and applications, customers should provide adequate design and operating safeguards.

TI does not warrant or represent that any license, either express or implied, is granted under any TI patent right, copyright, mask work right, or other TI intellectual property right relating to any combination, machine, or process in which TI products or services are used. Information published by TI regarding third-party products or services does not constitute a license from TI to use such products or services or a warranty or endorsement thereof. Use of such information may require a license from a third party under the patents or other intellectual property of the third party, or a license from TI under the patents or other intellectual property of TI.

Reproduction of TI information in TI data books or data sheets is permissible only if reproduction is without alteration and is accompanied by all associated warranties, conditions, limitations, and notices. Reproduction of this information with alteration is an unfair and deceptive business practice. TI is not responsible or liable for such altered documentation. Information of third parties may be subject to additional restrictions.

Resale of TI products or services with statements different from or beyond the parameters stated by TI for that product or service voids all express and any implied warranties for the associated TI product or service and is an unfair and deceptive business practice. TI is not responsible or liable for any such statements.

TI products are not authorized for use in safety-critical applications (such as life support) where a failure of the TI product would reasonably be expected to cause severe personal injury or death, unless officers of the parties have executed an agreement specifically governing such use. Buyers represent that they have all necessary expertise in the safety and regulatory ramifications of their applications, and acknowledge and agree that they are solely responsible for all legal, regulatory and safety-related requirements concerning their products and any use of TI products in such safety-critical applications, notwithstanding any applications-related information or support that may be provided by TI. Further, Buyers must fully indemnify TI and its representatives against any damages arising out of the use of TI products in such safety-critical applications.

TI products are neither designed nor intended for use in military/aerospace applications or environments unless the TI products are specifically designated by TI as military-grade or "enhanced plastic." Only products designated by TI as military-grade meet military specifications. Buyers acknowledge and agree that any such use of TI products which TI has not designated as military-grade is solely at the Buyer's risk, and that they are solely responsible for compliance with all legal and regulatory requirements in connection with such use.

TI products are neither designed nor intended for use in automotive applications or environments unless the specific TI products are designated by TI as compliant with ISO/TS 16949 requirements. Buyers acknowledge and agree that, if they use any non-designated products in automotive applications, TI will not be responsible for any failure to meet such requirements.

Following are URLs where you can obtain information on other Texas Instruments products and application solutions:

| <b>Products</b>       |                                                                    | <b>Applications</b> |                                                                          |
|-----------------------|--------------------------------------------------------------------|---------------------|--------------------------------------------------------------------------|
| Amplifiers            | <a href="http://amplifier.ti.com">amplifier.ti.com</a>             | Audio               | <a href="http://www.ti.com/audio">www.ti.com/audio</a>                   |
| Data Converters       | <a href="http://dataconverter.ti.com">dataconverter.ti.com</a>     | Automotive          | <a href="http://www.ti.com/automotive">www.ti.com/automotive</a>         |
| DSP                   | <a href="http://dsp.ti.com">dsp.ti.com</a>                         | Broadband           | <a href="http://www.ti.com/broadband">www.ti.com/broadband</a>           |
| Interface             | <a href="http://interface.ti.com">interface.ti.com</a>             | Digital Control     | <a href="http://www.ti.com/digitalcontrol">www.ti.com/digitalcontrol</a> |
| Logic                 | <a href="http://logic.ti.com">logic.ti.com</a>                     | Military            | <a href="http://www.ti.com/military">www.ti.com/military</a>             |
| Power Mgmt            | <a href="http://power.ti.com">power.ti.com</a>                     | Optical Networking  | <a href="http://www.ti.com/opticalnetwork">www.ti.com/opticalnetwork</a> |
| Microcontrollers      | <a href="http://microcontroller.ti.com">microcontroller.ti.com</a> | Security            | <a href="http://www.ti.com/security">www.ti.com/security</a>             |
| RFID                  | <a href="http://www.ti-rfid.com">www.ti-rfid.com</a>               | Telephony           | <a href="http://www.ti.com/telephony">www.ti.com/telephony</a>           |
| Low Power<br>Wireless | <a href="http://www.ti.com/lpw">www.ti.com/lpw</a>                 | Video & Imaging     | <a href="http://www.ti.com/video">www.ti.com/video</a>                   |
|                       |                                                                    | Wireless            | <a href="http://www.ti.com/wireless">www.ti.com/wireless</a>             |

Mailing Address: Texas Instruments, Post Office Box 655303, Dallas, Texas 75265  
Copyright © 2007, Texas Instruments Incorporated