

CY74FCT2646T

8-BIT REGISTERED TRANSCEIVER WITH 3-STATE OUTPUTS

SCCS043C – SEPTEMBER 1994 – REVISED NOVEMBER 2001

- Function and Pinout Compatible With FCT and F Logic
- Reduced V_{OH} (Typically = 3.3 V) Versions of Equivalent FCT Functions
- 25- Ω Output Series Resistors to Reduce Transmission-Line Reflection Noise
- Edge-Rate Control Circuitry for Significantly Improved Noise Characteristics
- I_{off} Supports Partial-Power-Down Mode Operation
- Matched Rise and Fall Times
- ESD Protection Exceeds JESD 22
 - 2000-V Human-Body Model (A114-A)
 - 200-V Machine Model (A115-A)
 - 1000-V Charged-Device Model (C101)
- Fully Compatible With TTL Input and Output Logic Levels
- 12-mA Output Sink Current
15-mA Output Source Current
- Independent Register for A and B Buses
- 3-State Outputs

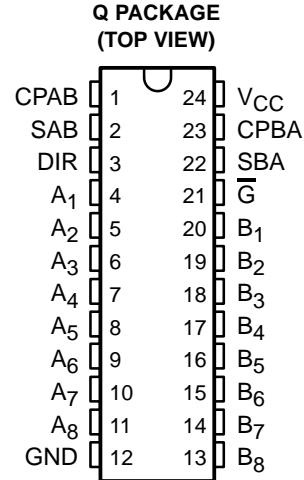

description

The CY74FCT2646T consists of a bus transceiver circuit with 3-state, D-type flip-flops, and control circuitry arranged for multiplexed transmission of data directly from the input bus or from the internal registers. Data on the A or B bus is clocked into the registers as the appropriate clock pin goes to a high logic level. Output-enable (\overline{G}) and direction-control (DIR) inputs determine the transceiver function. On-chip termination resistors at the outputs reduce system noise caused by reflections, so that the CY74FCT2646T can replace the CY74FCT646T in an existing design.

In the transceiver mode, data present at the high-impedance port can be stored in either the A or B register, or in both. Select controls (SAB, SBA) can multiplex stored and real-time (transparent mode) data. DIR determines which bus receives data when \overline{G} is active low. In the isolation mode (\overline{G} is high), A data can be stored in the B register and/or B data can be stored in the A register.

This device is fully specified for partial-power-down applications using I_{off} . The I_{off} circuitry disables the outputs, preventing damaging current backflow through the device when it is powered down.

PIN DESCRIPTION

| NAME | DESCRIPTION |
|---------------------|---|
| A | Data register A inputs, data register B outputs |
| B | Data register B inputs, data register A outputs |
| CPAB, CPBA | Clock pulse inputs |
| SAB, SBA | Output data source select inputs |
| DIR, \overline{G} | Output-enable inputs |



Please be aware that an important notice concerning availability, standard warranty, and use in critical applications of Texas Instruments semiconductor products and disclaimers thereto appears at the end of this data sheet.

PRODUCTION DATA information is current as of publication date. Products conform to specifications per the terms of Texas Instruments standard warranty. Production processing does not necessarily include testing of all parameters.

**TEXAS
INSTRUMENTS**

POST OFFICE BOX 655303 • DALLAS, TEXAS 75265

Copyright © 2001, Texas Instruments Incorporated

CY74FCT2646T
8-BIT REGISTERED TRANSCEIVER
WITH 3-STATE OUTPUTS

SCCS043C – SEPTEMBER 1994 – REVISED NOVEMBER 2001

ORDERING INFORMATION

| TA | PACKAGE† | | SPEED (ns) | ORDERABLE PART NUMBER | TOP-SIDE MARKING |
|---------------|----------|---------------|------------|-----------------------|------------------|
| -40°C to 85°C | QSOP – Q | Tape and reel | 5.4 | CY74FCT2646CTQCT | FCT2646C |
| | QSOP – Q | Tape and reel | 6.3 | CY74FCT2646ATQCT | FCT2646A |

† Package drawings, standard packing quantities, thermal data, symbolization, and PCB design guidelines are available at www.ti.com/sc/package.

FUNCTION TABLE

| INPUTS | | | | | | DATA I/O‡ | | OPERATION OR FUNCTION |
|----------------|-----|--------|--------|-----|-----|--------------------------------|--------------------------------|---------------------------|
| \overline{G} | DIR | CPAB | CPBA | SAB | SBA | A ₁ –A ₈ | B ₁ –B ₈ | |
| H | X | H or L | H or L | X | X | Input | Input | Isolation |
| H | X | ↑ | ↑ | X | X | Input | Input | Store A and B data |
| L | L | X | X | X | L | Output | Input | Real-time B data to A bus |
| L | L | X | H or L | X | H | Output | Input | Stored B data to A bus |
| L | H | X | X | L | X | Input | Output | Real-time A data to B bus |
| L | H | H or L | X | H | X | Input | Output | Stored A data to B bus |

H = High logic level, L = Low logic level, X = Don't care, ↑ = Low-to-high clock transition

‡ The data output functions can be enabled or disabled by various signals at the \overline{G} or DIR inputs. Data input functions always are enabled, i.e., data at the bus pins is stored on every low-to-high transition of the clock inputs.



CY74FCT2646T
8-BIT REGISTERED TRANSCEIVER
WITH 3-STATE OUTPUTS

SCCS043C – SEPTEMBER 1994 – REVISED NOVEMBER 2001

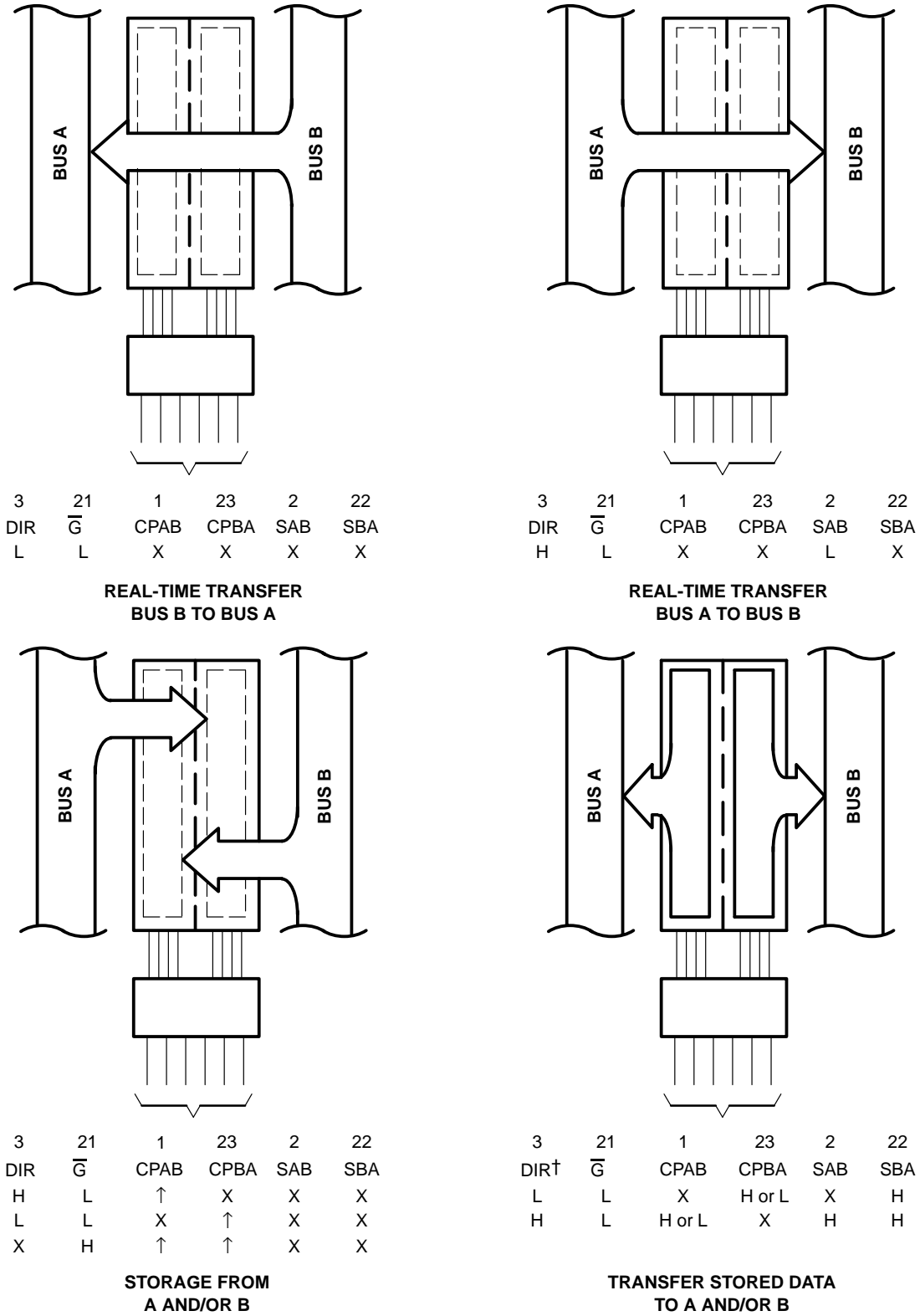

† Cannot transfer data to A bus and B bus simultaneously.

Figure 1. Bus-Management Functions

CY74FCT2646T
8-BIT REGISTERED TRANSCEIVER
WITH 3-STATE OUTPUTS

SCCS043C – SEPTEMBER 1994 – REVISED NOVEMBER 2001

logic diagram

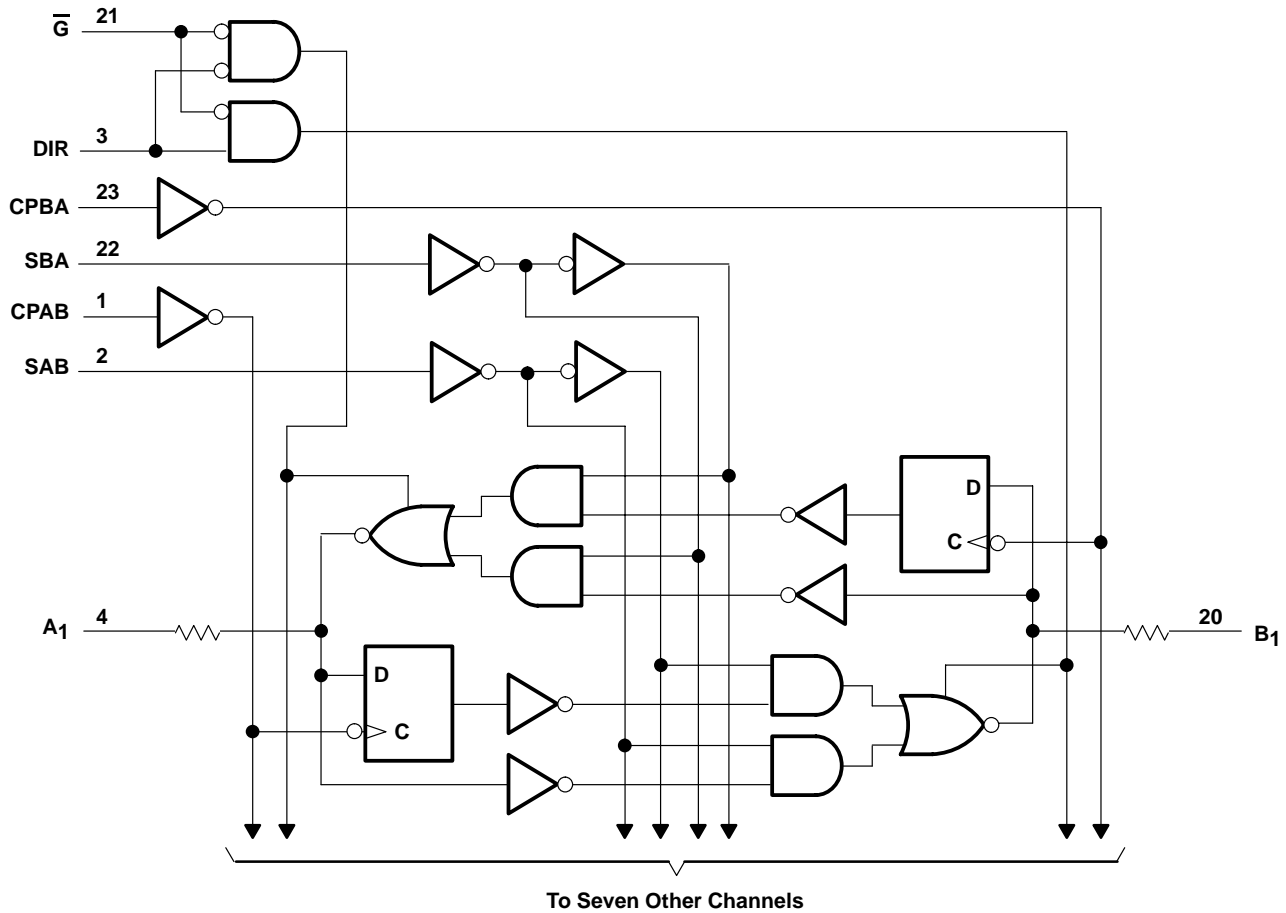

absolute maximum ratings over operating free-air temperature range (unless otherwise noted)†

| | |
|---|----------------|
| Supply voltage range to ground potential | -0.5 V to 7 V |
| DC input voltage range | -0.5 V to 7 V |
| DC output voltage range | -0.5 V to 7 V |
| DC output current (maximum sink current/pin) | 120 mA |
| Package thermal impedance, θ_{JA} (see Note 1) | 61°C/W |
| Ambient temperature range with power applied, T_A | -65°C to 135°C |
| Storage temperature range, T_{stg} | -65°C to 150°C |

† Stresses beyond those listed under “absolute maximum ratings” may cause permanent damage to the device. These are stress ratings only, and functional operation of the device at these or any other conditions beyond those indicated under “recommended operating conditions” is not implied.

Exposure to absolute-maximum-rated conditions for extended periods may affect device reliability.
 NOTE 1: The package thermal impedance is calculated in accordance with JESD 51-7.



CY74FCT2646T
8-BIT REGISTERED TRANSCEIVER
WITH 3-STATE OUTPUTS

SCCS043C – SEPTEMBER 1994 – REVISED NOVEMBER 2001

recommended operating conditions (see Note 2)

| | MIN | NOM | MAX | UNIT |
|---|------|-----|------|------|
| V _{CC} Supply voltage | 4.75 | 5 | 5.25 | V |
| V _{IH} High-level input voltage | 2 | | | V |
| V _{IL} Low-level input voltage | | | 0.8 | V |
| I _{OH} High-level output current | | | -15 | mA |
| I _{OL} Low-level output current | | | 12 | mA |
| T _A Operating free-air temperature | -40 | | 85 | °C |

NOTE 2: All unused inputs of the device must be held at V_{CC} or GND to ensure proper device operation.



CY74FCT2646T
8-BIT REGISTERED TRANSCEIVER
WITH 3-STATE OUTPUTS

SCCS043C – SEPTEMBER 1994 – REVISED NOVEMBER 2001

electrical characteristics over recommended operating free-air temperature range (unless otherwise noted)

| PARAMETER | TEST CONDITIONS | | MIN | TYP† | MAX | UNIT |
|--------------------|---|--|--|------|------|--------|
| V _{IK} | V _{CC} = 4.75, | I _{IN} = -18 mA | | -0.7 | -1.2 | V |
| V _{OH} | V _{CC} = 4.75, | I _{OH} = -15 mA | 2.4 | 3.3 | | V |
| V _{OL} | V _{CC} = 4.75, | I _{OL} = 12 mA | | 0.3 | 0.55 | V |
| R _{out} | V _{CC} = 4.75, | I _{OL} = 12 mA | 20 | 25 | 40 | Ω |
| V _{hys} | All inputs | | | 0.2 | | V |
| I _{IH} | V _{CC} = 5.25 V | V _{IN} = V _{CC} | | | 5 | μA |
| | | V _{IN} = 2.7 V | | | ±1 | |
| I _{IL} | V _{CC} = 5.25 V, | V _{IN} = 0.5 V | | | ±1 | μA |
| I _{OZH} | V _{CC} = 5.25 V, | V _{OUT} = 2.7 V | | | 10 | μA |
| I _{OZL} | V _{CC} = 5.25 V, | V _{OUT} = 0.5 V | | | -10 | μA |
| I _{OS} ‡ | V _{CC} = 5.25 V, | V _{OUT} = 0 V | -60 | -120 | -225 | mA |
| I _{off} | V _{CC} = 0 V, | V _{OUT} = 4.5 V | | | ±1 | μA |
| I _{CC} | V _{CC} = 5.25 V, | V _{IN} ≤ 0.2 V, V _{IN} ≥ V _{CC} - 0.2 V | | 0.1 | 0.2 | mA |
| ΔI _{CC} | V _{CC} = 5.25 V, V _{IN} = 3.4 V§, f ₁ = 0, Outputs open | | | 0.5 | 2 | mA |
| I _{CCD} ¶ | V _{CC} = 5.25 V, One input switching at 50% duty cycle, Outputs open, G = DIR = GND, GAB = GBA = GND, V _{IN} ≤ 0.2 V or V _{IN} ≥ V _{CC} - 0.2 V | | | 0.06 | 0.12 | mA/MHz |
| I _C # | V _{CC} = 5.25 V, Outputs open, G = DIR = GND, GAB = GBA = GND | One input switching at f ₁ = 5 MHz at 50% duty cycle | V _{IN} ≤ 0.2 V or V _{IN} ≥ V _{CC} - 0.2 V | 0.7 | 1.4 | mA |
| | | | V _{IN} = 3.4 V or GND | 1.2 | 3.4 | |
| | | Eight bits switching at f ₁ = 5 MHz at 50% duty cycle | V _{IN} ≤ 0.2 V or V _{IN} ≥ V _{CC} - 0.2 V | 2.8 | 5.6 | |
| | | | V _{IN} = 3.4 V or GND | 5.1 | 14.6 | |
| C _i | | | | 6 | 10 | pF |
| C _o | | | | 8 | 12 | pF |

† Typical values are at V_{CC} = 5 V, T_A = 25°C.

‡ Not more than one output should be shorted at a time. Duration of short should not exceed one second. The use of high-speed test apparatus and/or sample-and-hold techniques are preferable to minimize internal chip heating and more accurately reflect operational values. Otherwise, prolonged shorting of a high output can raise the chip temperature well above normal and cause invalid readings in other parametric tests. In any sequence of parameter tests, I_{OS} tests should be performed last.

§ Per TTL-driven input (V_{IN} = 3.4 V); all other inputs at V_{CC} or GND

¶ This parameter is derived for use in total power-supply calculations.

$$\# I_C = I_{CC} + \Delta I_{CC} \times D_H \times N_T + I_{CCD} (f_0/2 + f_1 \times N_1)$$

Where:

- I_C = Total supply current
- I_{CC} = Power-supply current with CMOS input levels
- ΔI_{CC} = Power-supply current for a TTL high input (V_{IN} = 3.4 V)
- D_H = Duty cycle for TTL inputs high
- N_T = Number of TTL inputs at D_H
- I_{CCD} = Dynamic current caused by an input transition pair (HLH or LHL)
- f₀ = Clock frequency for registered devices, otherwise zero
- f₁ = Input signal frequency
- N₁ = Number of inputs changing at f₁

All currents are in milliamperes and all frequencies are in megahertz.

|| Values for these conditions are examples of the I_{CC} formula.



CY74FCT2646T
8-BIT REGISTERED TRANSCEIVER
WITH 3-STATE OUTPUTS

SCCS043C – SEPTEMBER 1994 – REVISED NOVEMBER 2001

timing requirements over recommended operating free-air temperature range (unless otherwise noted) (see Figure 2)

| | | CY74FCT2646AT | | CY74FCT2646CT | | UNIT |
|----------|-----------------------------|--|-----|---------------|-----|------|
| | | MIN | MAX | MIN | MAX | |
| t_w | Pulse duration, high or low | 5 | | 5 | | ns |
| t_{su} | Setup time, high or low | Data before CPBA \uparrow or CPAB \uparrow | | 2 | | ns |
| t_h | Hold time, high or low | Data after CPBA \uparrow or CPAB \uparrow | | 1.5 | | ns |

switching characteristics over operating free-air temperature range (see Figure 2)

| PARAMETER | FROM (INPUT) | TO (OUTPUT) | CY74FCT2646AT | | CY74FCT2646CT | | UNIT |
|-----------|--------------|-------------|---------------|-----|---------------|-----|------|
| | | | MIN | MAX | MIN | MAX | |
| t_{PLH} | A or B | B or A | 1.5 | 6.3 | 1.5 | 5.4 | ns |
| t_{PHL} | | | 1.5 | 6.3 | 1.5 | 5.4 | |
| t_{PZH} | \bar{G} | A or B | 1.5 | 9.8 | 1.5 | 7.8 | ns |
| t_{PZL} | | | 1.5 | 9.8 | 1.5 | 7.8 | |
| t_{PZH} | DIR | A or B | 1.5 | 9.8 | 1.5 | 7.8 | ns |
| t_{PZL} | | | 1.5 | 9.8 | 1.5 | 7.8 | |
| t_{PHZ} | \bar{G} | A or B | 1.5 | 6.3 | 1.5 | 6.3 | ns |
| t_{PLZ} | | | 1.5 | 6.3 | 1.5 | 6.3 | |
| t_{PHZ} | DIR | A or B | 1.5 | 6.3 | 1.5 | 6.3 | ns |
| t_{PLZ} | | | 1.5 | 6.3 | 1.5 | 6.3 | |
| t_{PLH} | CPAB or CPBA | B or A | 1.5 | 6.3 | 1.5 | 5.7 | ns |
| t_{PHL} | | | 1.5 | 6.3 | 1.5 | 5.7 | |
| t_{PLH} | SAB or SBA | B or A | 1.5 | 7.7 | 1.5 | 6.2 | ns |
| t_{PHL} | | | 1.5 | 7.7 | 1.5 | 6.2 | |

CY74FCT2646T
8-BIT REGISTERED TRANSCEIVER
WITH 3-STATE OUTPUTS

SCCS043C – SEPTEMBER 1994 – REVISED NOVEMBER 2001

PARAMETER MEASUREMENT INFORMATION

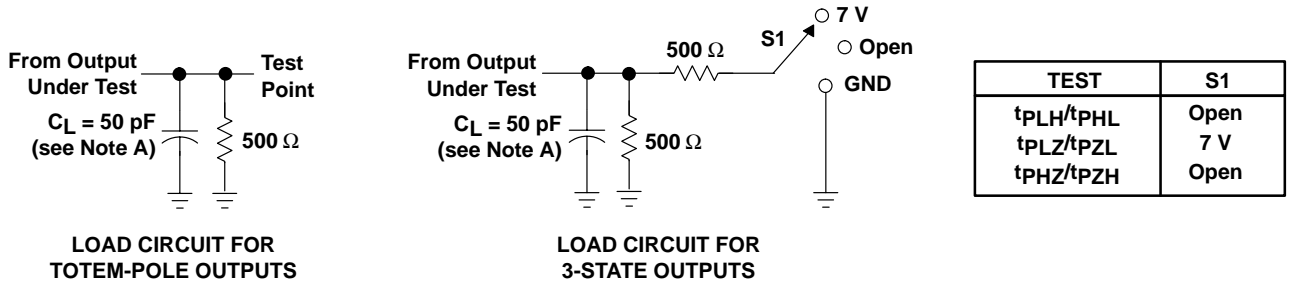

LOAD CIRCUIT FOR TOTEM-POLE OUTPUTS

LOAD CIRCUIT FOR 3-STATE OUTPUTS

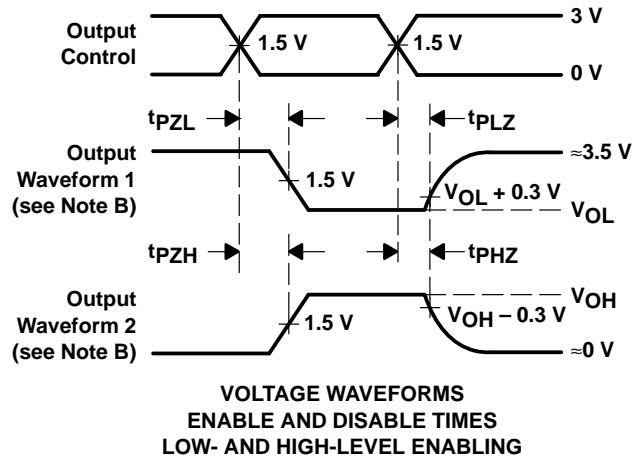
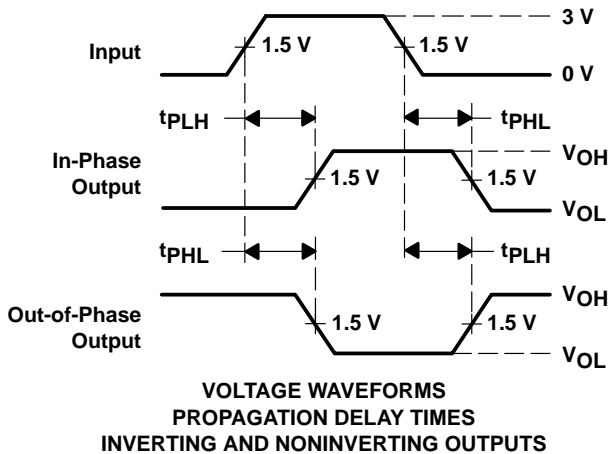
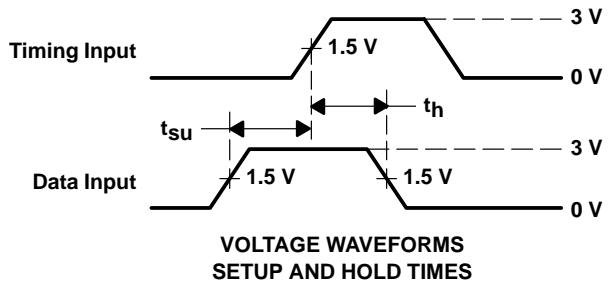
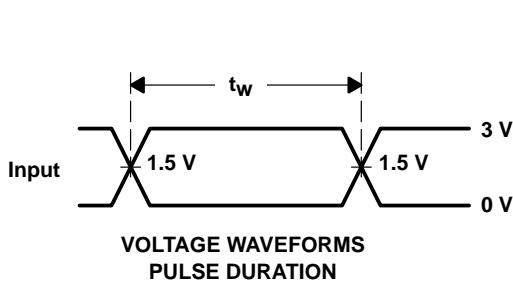

- NOTES: A. C_L includes probe and jig capacitance.
 B. Waveform 1 is for an output with internal conditions such that the output is low except when disabled by the output control. Waveform 2 is for an output with internal conditions such that the output is high except when disabled by the output control.
 C. The outputs are measured one at a time with one input transition per measurement.

Figure 2. Load Circuit and Voltage Waveforms

PACKAGING INFORMATION

| Orderable Device | Status ⁽¹⁾ | Package Type | Package Drawing | Pins | Package Qty | Eco Plan ⁽²⁾ | Lead/Ball Finish | MSL Peak Temp ⁽³⁾ |
|--------------------|-----------------------|--------------|-----------------|------|-------------|-------------------------|------------------|------------------------------|
| 74FCT2646ATQCTE4 | ACTIVE | SSOP/QSOP | DBQ | 24 | 2500 | Green (RoHS & no Sb/Br) | CU NIPDAU | Level-2-260C-1 YEAR |
| CY74FCT2646ATQCT | ACTIVE | SSOP/QSOP | DBQ | 24 | 2500 | Green (RoHS & no Sb/Br) | CU NIPDAU | Level-2-260C-1 YEAR |
| CY74FCT2646CTQCT | ACTIVE | SSOP/QSOP | DBQ | 24 | 2500 | Green (RoHS & no Sb/Br) | CU NIPDAU | Level-2-260C-1 YEAR |
| CY74FCT2646CTQCTE4 | ACTIVE | SSOP/QSOP | DBQ | 24 | 2500 | Green (RoHS & no Sb/Br) | CU NIPDAU | Level-2-260C-1 YEAR |
| CY74FCT2646CTQCTG4 | ACTIVE | SSOP/QSOP | DBQ | 24 | 2500 | Green (RoHS & no Sb/Br) | CU NIPDAU | Level-2-260C-1 YEAR |
| SN74FCT2646ATQCTG4 | ACTIVE | SSOP/QSOP | DBQ | 24 | 2500 | Green (RoHS & no Sb/Br) | CU NIPDAU | Level-2-260C-1 YEAR |

⁽¹⁾ The marketing status values are defined as follows:

ACTIVE: Product device recommended for new designs.

LIFEBUY: TI has announced that the device will be discontinued, and a lifetime-buy period is in effect.

NRND: Not recommended for new designs. Device is in production to support existing customers, but TI does not recommend using this part in a new design.

PREVIEW: Device has been announced but is not in production. Samples may or may not be available.

OBSOLETE: TI has discontinued the production of the device.

⁽²⁾ Eco Plan - The planned eco-friendly classification: Pb-Free (RoHS), Pb-Free (RoHS Exempt), or Green (RoHS & no Sb/Br) - please check <http://www.ti.com/productcontent> for the latest availability information and additional product content details.

TBD: The Pb-Free/Green conversion plan has not been defined.

Pb-Free (RoHS): TI's terms "Lead-Free" or "Pb-Free" mean semiconductor products that are compatible with the current RoHS requirements for all 6 substances, including the requirement that lead not exceed 0.1% by weight in homogeneous materials. Where designed to be soldered at high temperatures, TI Pb-Free products are suitable for use in specified lead-free processes.

Pb-Free (RoHS Exempt): This component has a RoHS exemption for either 1) lead-based flip-chip solder bumps used between the die and package, or 2) lead-based die adhesive used between the die and leadframe. The component is otherwise considered Pb-Free (RoHS compatible) as defined above.

Green (RoHS & no Sb/Br): TI defines "Green" to mean Pb-Free (RoHS compatible), and free of Bromine (Br) and Antimony (Sb) based flame retardants (Br or Sb do not exceed 0.1% by weight in homogeneous material)

⁽³⁾ MSL, Peak Temp. -- The Moisture Sensitivity Level rating according to the JEDEC industry standard classifications, and peak solder temperature.

Important Information and Disclaimer:The information provided on this page represents TI's knowledge and belief as of the date that it is provided. TI bases its knowledge and belief on information provided by third parties, and makes no representation or warranty as to the accuracy of such information. Efforts are underway to better integrate information from third parties. TI has taken and continues to take reasonable steps to provide representative and accurate information but may not have conducted destructive testing or chemical analysis on incoming materials and chemicals. TI and TI suppliers consider certain information to be proprietary, and thus CAS numbers and other limited information may not be available for release.

In no event shall TI's liability arising out of such information exceed the total purchase price of the TI part(s) at issue in this document sold by TI to Customer on an annual basis.

TAPE AND REEL BOX INFORMATION

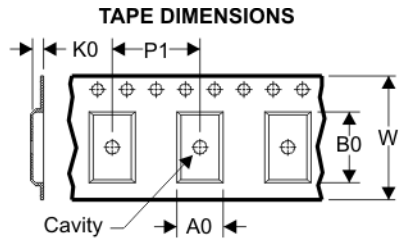

| | |
|----|---|
| A0 | Dimension designed to accommodate the component width |
| B0 | Dimension designed to accommodate the component length |
| K0 | Dimension designed to accommodate the component thickness |
| W | Overall width of the carrier tape |
| P1 | Pitch between successive cavity centers |

QUADRANT ASSIGNMENTS FOR PIN 1 ORIENTATION IN TAPE

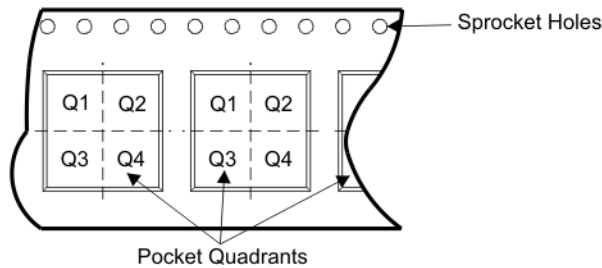

| Device | Package | Pins | Site | Reel Diameter (mm) | Reel Width (mm) | A0 (mm) | B0 (mm) | K0 (mm) | P1 (mm) | W (mm) | Pin1 Quadrant |
|------------------|---------|------|---------|--------------------|-----------------|---------|---------|---------|---------|--------|---------------|
| CY74FCT2646ATQCT | DBQ | 24 | SITE 41 | 330 | 16 | 6.5 | 9.0 | 2.1 | 8 | 16 | Q1 |
| CY74FCT2646CTQCT | DBQ | 24 | SITE 41 | 330 | 16 | 6.5 | 9.0 | 2.1 | 8 | 16 | Q1 |

TAPE AND REEL BOX DIMENSIONS



| Device | Package | Pins | Site | Length (mm) | Width (mm) | Height (mm) |
|------------------|---------|------|---------|-------------|------------|-------------|
| CY74FCT2646ATQCT | DBQ | 24 | SITE 41 | 346.0 | 346.0 | 33.0 |
| CY74FCT2646CTQCT | DBQ | 24 | SITE 41 | 346.0 | 346.0 | 33.0 |

DBQ (R-PDSO-G24)

PLASTIC SMALL-OUTLINE PACKAGE

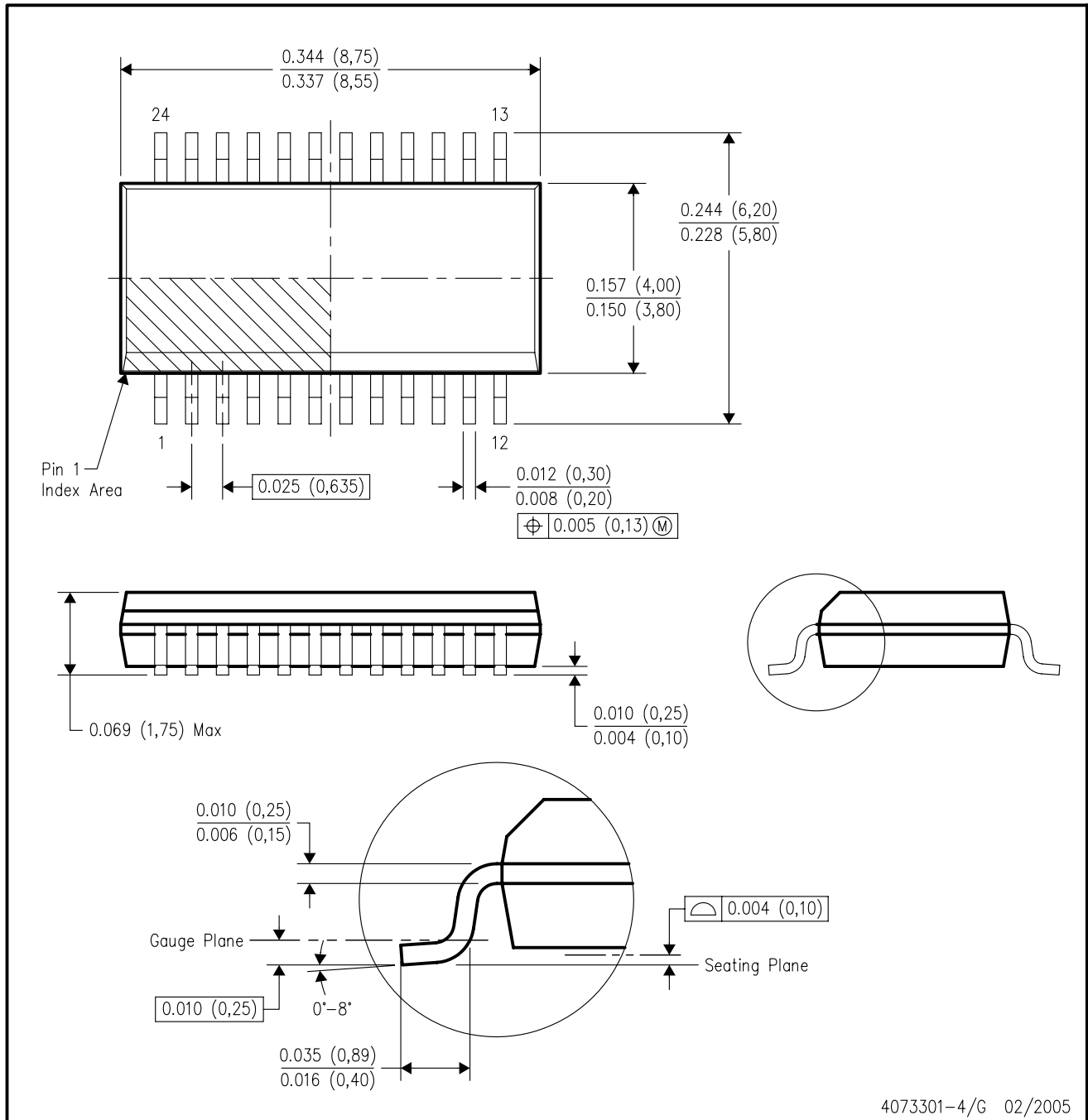

- NOTES:
- A. All linear dimensions are in inches (millimeters).
 - B. This drawing is subject to change without notice.
 - C. Body dimensions do not include mold flash or protrusion not to exceed 0.006 (0,15) per side.
 - D. Falls within JEDEC MO-137 variation AE.

IMPORTANT NOTICE

Texas Instruments Incorporated and its subsidiaries (TI) reserve the right to make corrections, modifications, enhancements, improvements, and other changes to its products and services at any time and to discontinue any product or service without notice. Customers should obtain the latest relevant information before placing orders and should verify that such information is current and complete. All products are sold subject to TI's terms and conditions of sale supplied at the time of order acknowledgment.

TI warrants performance of its hardware products to the specifications applicable at the time of sale in accordance with TI's standard warranty. Testing and other quality control techniques are used to the extent TI deems necessary to support this warranty. Except where mandated by government requirements, testing of all parameters of each product is not necessarily performed.

TI assumes no liability for applications assistance or customer product design. Customers are responsible for their products and applications using TI components. To minimize the risks associated with customer products and applications, customers should provide adequate design and operating safeguards.

TI does not warrant or represent that any license, either express or implied, is granted under any TI patent right, copyright, mask work right, or other TI intellectual property right relating to any combination, machine, or process in which TI products or services are used. Information published by TI regarding third-party products or services does not constitute a license from TI to use such products or services or a warranty or endorsement thereof. Use of such information may require a license from a third party under the patents or other intellectual property of the third party, or a license from TI under the patents or other intellectual property of TI.

Reproduction of TI information in TI data books or data sheets is permissible only if reproduction is without alteration and is accompanied by all associated warranties, conditions, limitations, and notices. Reproduction of this information with alteration is an unfair and deceptive business practice. TI is not responsible or liable for such altered documentation. Information of third parties may be subject to additional restrictions.

Resale of TI products or services with statements different from or beyond the parameters stated by TI for that product or service voids all express and any implied warranties for the associated TI product or service and is an unfair and deceptive business practice. TI is not responsible or liable for any such statements.

TI products are not authorized for use in safety-critical applications (such as life support) where a failure of the TI product would reasonably be expected to cause severe personal injury or death, unless officers of the parties have executed an agreement specifically governing such use. Buyers represent that they have all necessary expertise in the safety and regulatory ramifications of their applications, and acknowledge and agree that they are solely responsible for all legal, regulatory and safety-related requirements concerning their products and any use of TI products in such safety-critical applications, notwithstanding any applications-related information or support that may be provided by TI. Further, Buyers must fully indemnify TI and its representatives against any damages arising out of the use of TI products in such safety-critical applications.

TI products are neither designed nor intended for use in military/aerospace applications or environments unless the TI products are specifically designated by TI as military-grade or "enhanced plastic." Only products designated by TI as military-grade meet military specifications. Buyers acknowledge and agree that any such use of TI products which TI has not designated as military-grade is solely at the Buyer's risk, and that they are solely responsible for compliance with all legal and regulatory requirements in connection with such use.

TI products are neither designed nor intended for use in automotive applications or environments unless the specific TI products are designated by TI as compliant with ISO/TS 16949 requirements. Buyers acknowledge and agree that, if they use any non-designated products in automotive applications, TI will not be responsible for any failure to meet such requirements.

Following are URLs where you can obtain information on other Texas Instruments products and application solutions:

Products

| | |
|-----------------------|--|
| Amplifiers | amplifier.ti.com |
| Data Converters | dataconverter.ti.com |
| DSP | dsp.ti.com |
| Interface | interface.ti.com |
| Logic | logic.ti.com |
| Power Mgmt | power.ti.com |
| Microcontrollers | microcontroller.ti.com |
| RFID | www.ti-rfid.com |
| Low Power Wireless | www.ti.com/lpw |

Applications

| | |
|--------------------|--|
| Audio | www.ti.com/audio |
| Automotive | www.ti.com/automotive |
| Broadband | www.ti.com/broadband |
| Digital Control | www.ti.com/digitalcontrol |
| Military | www.ti.com/military |
| Optical Networking | www.ti.com/opticalnetwork |
| Security | www.ti.com/security |
| Telephony | www.ti.com/telephony |
| Video & Imaging | www.ti.com/video |
| Wireless | www.ti.com/wireless |

Mailing Address: Texas Instruments, Post Office Box 655303, Dallas, Texas 75265
Copyright © 2007, Texas Instruments Incorporated