

CY54FCT646T, CY74FCT646T 8-BIT REGISTERED TRANSCEIVERS WITH 3-STATE OUTPUTS

SCCS031A – JULY 1994 – REVISED OCTOBER 2001

- Function, Pinout, and Drive Compatible With FCT and F Logic
- Reduced V_{OH} (Typically = 3.3 V) Versions of Equivalent FCT Functions
- Edge-Rate Control Circuitry for Significantly Improved Noise Characteristics
- I_{off} Supports Partial-Power-Down Mode Operation
- Matched Rise and Fall Times
- Fully Compatible With TTL Input and Output Logic Levels
- ESD Protection Exceeds JESD 22
 - 2000-V Human-Body Model (A114-A)
 - 200-V Machine Model (A115-A)
 - 1000-V Charged-Device Model (C101)
- Independent Register for A and B Buses
- CY54FCT646T
 - 48-mA Output Sink Current
 - 12-mA Output Source Current
- CY74FCT646T
 - 64-mA Output Sink Current
 - 32-mA Output Source Current
- 3-State Outputs

description

The 'FCT646T devices consist of a bus transceiver circuit with 3-state, D-type flip-flops, and control circuitry arranged for multiplexed transmission of data directly from the input bus or from the internal registers. Data on the A or B bus is clocked into the registers as the appropriate clock pin goes to a high logic level. Output-enable (\overline{G}) and direction (DIR) inputs control the transceiver function. In the transceiver mode, data present at the high-impedance port can be stored in either the A or B register, or in both. Select controls (SAB, SBA) can multiplex stored and real-time (transparent mode) data. DIR determines which bus receives data when \overline{G} is low. In the isolation mode (\overline{G} is high), A data can be stored in the B register and/or B data can be stored in the A register.

These devices are fully specified for partial-power-down applications using I_{off} . The I_{off} circuitry disables the outputs, preventing damaging current backflow through the device when it is powered down.

CY54FCT646T . . . D PACKAGE
CY74FCT646T . . . Q OR SO PACKAGE
(TOP VIEW)

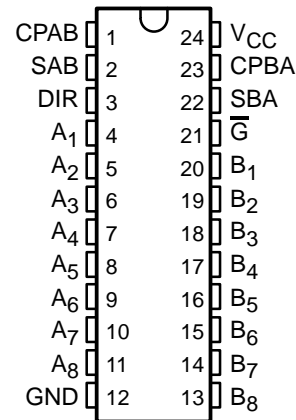

CY54FCT646T . . . L PACKAGE
(TOP VIEW)

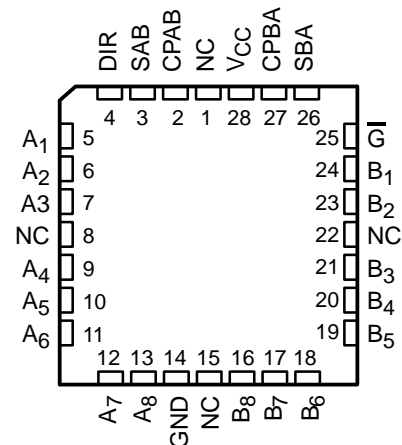

NC – No internal connection



Please be aware that an important notice concerning availability, standard warranty, and use in critical applications of Texas Instruments semiconductor products and disclaimers thereto appears at the end of this data sheet.

PRODUCTION DATA information is current as of publication date. Products conform to specifications per the terms of Texas Instruments standard warranty. Production processing does not necessarily include testing of all parameters.

 **TEXAS
INSTRUMENTS**

POST OFFICE BOX 655303 • DALLAS, TEXAS 75265

Copyright © 2001, Texas Instruments Incorporated
On products compliant to MIL-PRF-38535, all parameters are tested unless otherwise noted. On all other products, production processing does not necessarily include testing of all parameters.

CY54FCT646T, CY74FCT646T
8-BIT REGISTERED TRANSCEIVERS
WITH 3-STATE OUTPUTS

SCCS031A – JULY 1994 – REVISED OCTOBER 2001

PIN DESCRIPTION

NAME	DESCRIPTION
A	Data register A inputs, data register B outputs
B	Data register B inputs, data register A outputs
CPAB, CPBA	Clock-pulse inputs
SAB, SBA	Output data-source-select inputs
DIR, \overline{G}	Output-enable inputs

ORDERING INFORMATION

T _A	PACKAGE†		SPEED (ns)	ORDERABLE PART NUMBER	TOP-SIDE MARKING	
-40°C to 85°C	QSOP – Q	Tape and reel	5.4	CY74FCT646CTQCT	FCT646C	
	SOIC – SO	Tube	5.4	CY74FCT646CTSOC	FCT646C	
		Tape and reel	5.4	CY74FCT646CTSOCT		
	QSOP – Q	Tape and reel	6.3	CY74FCT646ATQCT	FCT646A	
		SOIC – SO	Tube	6.3	CY74FCT646ATSOC	FCT646A
	Tape and reel		6.3	CY74FCT646ATSOCT		
	-55°C to 125°C	QSOP – Q	Tape and reel	9	CY74FCT646TQCT	FCT646
		SOIC – SO	Tube	9	CY74FCT646TSOC	FCT646
Tape and reel			9	CY74FCT646TSOCT		
LCC – L		Tube	6	CY54FCT646CTLMB		
-55°C to 125°C	CDIP – D	Tube	7.7	CY54FCT646ATDMB		
	LCC – L	Tube	7.7	CY54FCT646ATLMB		
		Tube	11	CY54FCT646TLMB		

† Package drawings, standard packing quantities, thermal data, symbolization, and PCB design guidelines are available at www.ti.com/sc/package.

FUNCTION TABLE

INPUTS						DATA I/O‡		OPERATION OR FUNCTION
\overline{G}	DIR	CPAB	CPBA	SAB	SBA	A ₁ –A ₈	B ₁ –B ₈	
H	X	H or L	H or L	X	X	Input	Input	Isolation
H	X	↑	↑	X	X	Input	Input	Store A and B data
L	L	X	X	X	L	Output	Input	Real-time B data to A bus
L	L	X	H or L	X	H	Output	Input	Stored B data to A bus
L	H	X	X	L	X	Input	Output	Real-time A data to B bus
L	H	H or L	X	H	X	Input	Output	Stored A data to B bus

H = High logic level, L = Low logic level, ↑ = Low-to-high transition, X = Don't care

‡ The data output functions can be enabled or disabled by various signals at the \overline{G} or DIR inputs. Data input functions always are enabled, i.e., data at the bus pins is stored on every low-to-high transition of the clock inputs.



CY54FCT646T, CY74FCT646T
8-BIT REGISTERED TRANSCEIVERS
WITH 3-STATE OUTPUTS

SCCS031A – JULY 1994 – REVISED OCTOBER 2001

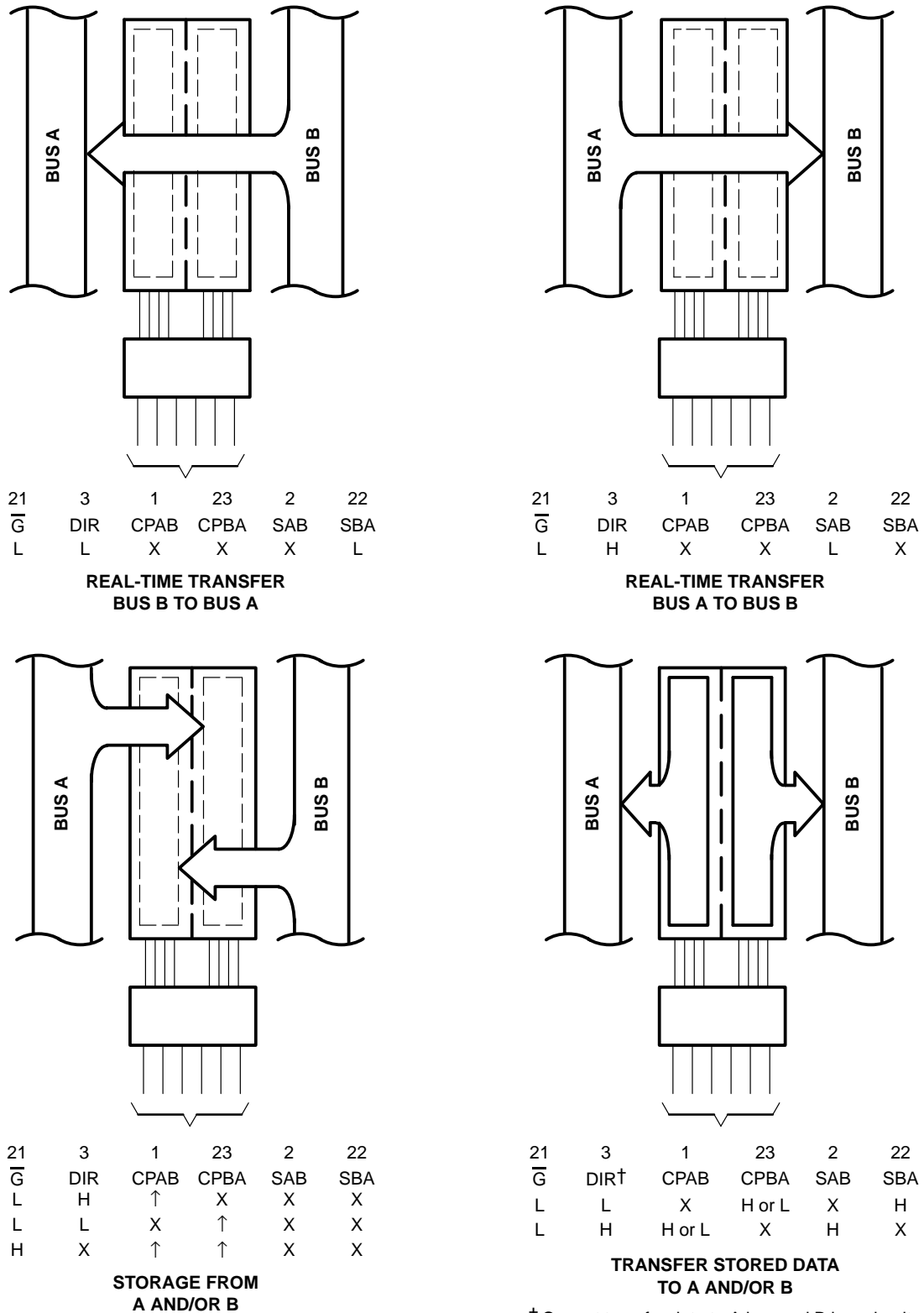

† Cannot transfer data to A bus and B bus simultaneously.

Figure 1. Bus-Management Functions

CY54FCT646T, CY74FCT646T 8-BIT REGISTERED TRANSCEIVERS WITH 3-STATE OUTPUTS

SCCS031A – JULY 1994 – REVISED OCTOBER 2001

logic diagram (positive logic)

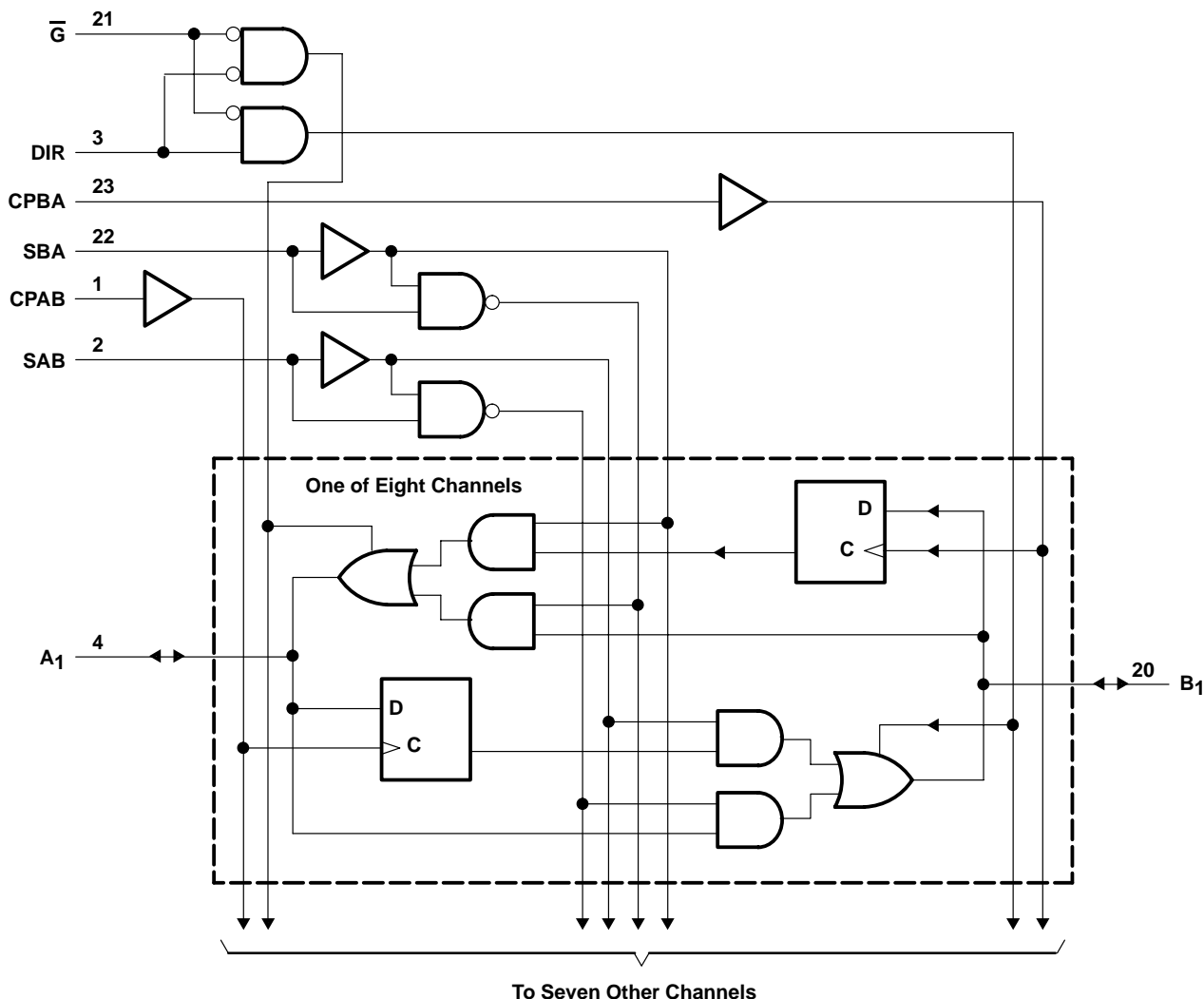

Pin numbers shown are for the Q and SO packages.

absolute maximum ratings over operating free-air temperature range (unless otherwise noted)[†]

Supply voltage range to ground potential	-0.5 V to 7 V
DC input voltage range	-0.5 V to 7 V
DC output voltage range	-0.5 V to 7 V
DC output current (maximum sink current/pin)	120 mA
Package thermal impedance, θ_{JA} (see Note 1): Q package	61°C/W
SO package	46°C/W
Ambient temperature range with power applied, T_A	-65°C to 135°C
Storage temperature range, T_{stg}	-65°C to 150°C

[†] Stresses beyond those listed under "absolute maximum ratings" may cause permanent damage to the device. These are stress ratings only, and functional operation of the device at these or any other conditions beyond those indicated under "recommended operating conditions" is not implied.

Exposure to absolute-maximum-rated conditions for extended periods may affect device reliability.

NOTE 1: The package thermal impedance is calculated in accordance with JESD 51-7.



POST OFFICE BOX 655303 • DALLAS, TEXAS 75265

CY54FCT646T, CY74FCT646T
8-BIT REGISTERED TRANSCEIVERS
WITH 3-STATE OUTPUTS

SCCS031A – JULY 1994 – REVISED OCTOBER 2001

recommended operating conditions (see Note 2)

	CY54FCT646T			CY74FCT646T			UNIT
	MIN	NOM	MAX	MIN	NOM	MAX	
V _{CC} Supply voltage	4.5	5	5.5	4.75	5	5.25	V
V _{IH} High-level input voltage	2			2			V
V _{IL} Low-level input voltage			0.8			0.8	V
I _{OH} High-level output current			-12			-32	mA
I _{OL} Low-level output current			48			64	mA
T _A Operating free-air temperature	-55		125	-40		85	°C

NOTE 2: All unused inputs of the device must be held at V_{CC} or GND to ensure proper device operation.



CY54FCT646T, CY74FCT646T
8-BIT REGISTERED TRANSCEIVERS
WITH 3-STATE OUTPUTS

SCCS031A – JULY 1994 – REVISED OCTOBER 2001

electrical characteristics over recommended operating free-air temperature range (unless otherwise noted)

PARAMETER	TEST CONDITIONS	CY54FCT646T			CY74FCT646T			UNIT
		MIN	TYP†	MAX	MIN	TYP†	MAX	
V _{IK}	V _{CC} = 4.5 V, I _{IN} = -18 mA	-0.7	-1.2					V
	V _{CC} = 4.75 V, I _{IN} = -18 mA				-0.7	-1.2		
V _{OH}	V _{CC} = 4.5 V, I _{OH} = -12 mA	2.4	3.3					V
	V _{CC} = 4.75 V	I _{OH} = -32 mA			2			
		I _{OH} = -15 mA			2.4	3.3		
V _{OL}	V _{CC} = 4.5 V, I _{OL} = 48 mA	0.3	0.55					V
	V _{CC} = 4.75 V, I _{OL} = 64 mA				0.3	0.55		
V _{hys}	All inputs	0.2			0.2			V
I _I	V _{CC} = 5.5 V, V _{IN} = V _{CC}			5				μA
	V _{CC} = 5.25 V, V _{IN} = V _{CC}					5		
I _{IH}	V _{CC} = 5.5 V, V _{IN} = 2.7 V			±1				μA
	V _{CC} = 5.25 V, V _{IN} = 2.7 V					±1		
I _{IL}	V _{CC} = 5.5 V, V _{IN} = 0.5 V			±1				μA
	V _{CC} = 5.25 V, V _{IN} = 0.5 V					±1		
I _{OZH}	V _{CC} = 5.5 V, V _{OUT} = 2.7 V			10				μA
	V _{CC} = 5.25 V, V _{OUT} = 2.7 V					10		
I _{OZL}	V _{CC} = 5.5 V, V _{OUT} = 0.5 V			-10				μA
	V _{CC} = 5.25 V, V _{OUT} = 0.5 V					-10		
I _{OS} ‡	V _{CC} = 5.5 V, V _{OUT} = 0 V	-60	-120	-225				mA
	V _{CC} = 5.25 V, V _{OUT} = 0 V				-60	-120	-225	
I _{off}	V _{CC} = 0 V, V _{OUT} = 4.5 V			±1			±1	μA
I _{CC}	V _{CC} = 5.5 V, V _{IN} ≤ 0.2 V, V _{IN} ≥ V _{CC} - 0.2 V	0.1	0.2					mA
	V _{CC} = 5.25 V, V _{IN} ≤ 0.2 V, V _{IN} ≥ V _{CC} - 0.2 V				0.1	0.2		
ΔI _{CC}	V _{CC} = 5.5 V, V _{IN} = 3.4 V§, f ₁ = 0, Outputs open	0.5	2					mA
	V _{CC} = 5.25 V, V _{IN} = 3.4 V§, f ₁ = 0, Outputs open				0.5	2		
I _{CCD} ¶	V _{CC} = 5.5 V, One input switching at 50% duty cycle, Outputs open, \overline{G} = DIR = GND, SAB = \overline{SBA} = GND, V _{IN} ≤ 0.2 V or V _{IN} ≥ V _{CC} - 0.2 V	0.06	0.12					mA/ MHz
	V _{CC} = 5.25 V, One input switching at 50% duty cycle, Outputs open, \overline{G} = DIR = GND, SAB = \overline{SBA} = GND, V _{IN} ≤ 0.2 V or V _{IN} ≥ V _{CC} - 0.2 V				0.06	0.12		

† Typical values are at V_{CC} = 5 V, T_A = 25°C.

‡ Not more than one output should be shorted at a time. Duration of short should not exceed one second. The use of high-speed test apparatus and/or sample-and-hold techniques are preferable to minimize internal chip heating and more accurately reflect operational values. Otherwise, prolonged shorting of a high output can raise the chip temperature well above normal and cause invalid readings in other parametric tests. In any sequence of parameter tests, I_{OS} tests should be performed last.

§ Per TTL-driven input (V_{IN} = 3.4 V); all other inputs at V_{CC} or GND

¶ This parameter is derived for use in total power-supply calculations.



CY54FCT646T, CY74FCT646T
8-BIT REGISTERED TRANSCEIVERS
WITH 3-STATE OUTPUTS

SCCS031A – JULY 1994 – REVISED OCTOBER 2001

electrical characteristics over recommended operating free-air temperature range (unless otherwise noted) (continued)

PARAMETER	TEST CONDITIONS			CY54FCT646T		CY74FCT646T		UNIT
				MIN	TYP†	MAX	MIN	
I _C [#]	V _{CC} = 5.5 V, f ₀ = 10 MHz, Outputs open, $\overline{G} = \overline{DIR} = \overline{GND}$, SAB = $\overline{SBA} = \overline{GND}$	One bit switching at f ₁ = 5 MHz at 50% duty cycle	V _{IN} ≤ 0.2 V or V _{IN} ≥ V _{CC} – 0.2 V	0.7	1.4			mA
			V _{IN} = 3.4 V or GND	1.2	3.4			
		Eight bits switching at f ₁ = 5 MHz at 50% duty cycle	V _{IN} ≤ 0.2 V or V _{IN} ≥ V _{CC} – 0.2 V	2.8	5.6			
			V _{IN} = 3.4 V or GND	5.1	14.6			
	V _{CC} = 5.25 V, f ₀ = 10 MHz, Outputs open, $\overline{G} = \overline{DIR} = \overline{GND}$, SAB = $\overline{SBA} = \overline{GND}$	One bit switching at f ₁ = 5 MHz at 50% duty cycle	V _{IN} ≤ 0.2 V or V _{IN} ≥ V _{CC} – 0.2 V			0.7	1.4	mA
			V _{IN} = 3.4 V or GND			1.2	3.4	
		Eight bits switching at f ₁ = 5 MHz at 50% duty cycle	V _{IN} ≤ 0.2 V or V _{IN} ≥ V _{CC} – 0.2 V			2.8	5.6	
			V _{IN} = 3.4 V or GND			5.1	14.6	
C _i				6	10	6	10	pF
C _o				8	12	8	12	pF

[#] I_C = I_{CC} + ΔI_{CC} × D_H × N_T + I_{CCD}(f₀/2 + f₁ × N₁)

Where:

I_C = Total supply current

I_{CC} = Power-supply current with CMOS input levels

ΔI_{CC} = Power-supply current for a TTL high input (V_{IN} = 3.4 V)

D_H = Duty cycle for TTL inputs high

N_T = Number of TTL inputs at D_H

I_{CCD} = Dynamic current caused by an input transition pair (HLH or LHL)

f₀ = Clock frequency for registered devices, otherwise zero

f₁ = Input signal frequency

N₁ = Number of inputs changing at f₁

All currents are in milliamperes and all frequencies are in megahertz.

|| Values for these conditions are examples of the I_{CC} formula.

CY54FCT646T, CY74FCT646T
8-BIT REGISTERED TRANSCEIVERS
WITH 3-STATE OUTPUTS

SCCS031A – JULY 1994 – REVISED OCTOBER 2001

timing requirements over recommended operating free-air temperature range (unless otherwise noted) (see Figure 2)

		CY54FCT646T		CY54FCT646AT		CY54FCT646CT		UNIT
		MIN	MAX	MIN	MAX	MIN	MAX	
t_w	Pulse duration	6		5		5		ns
t_{su}	Setup time, data before CPAB \uparrow or CPBA \uparrow	4.5		2		2		ns
t_h	Hold time, data after CPAB \uparrow or CPBA \uparrow	2		1.5		1.5		ns

timing requirements over recommended operating free-air temperature range (unless otherwise noted) (see Figure 2)

		CY74FCT646T		CY74FCT646AT		CY74FCT646CT		UNIT
		MIN	MAX	MIN	MAX	MIN	MAX	
t_w	Pulse duration	6		5		5		ns
t_{su}	Setup time, data before CPAB \uparrow or CPBA \uparrow	4		2		2		ns
t_h	Hold time, data after CPAB \uparrow or CPBA \uparrow	2		1.5		1.5		ns

switching characteristics over operating free-air temperature range (see Figure 2)

PARAMETER	FROM (INPUT)	TO (OUTPUT)	CY54FCT646T		CY54FCT646AT		CY54FCT646CT		UNIT
			MIN	MAX	MIN	MAX	MIN	MAX	
t_{PLH}	A or B	B or A	2	11	2	7.7	1.5	6	ns
t_{PHL}			2	11	2	7.7	1.5	6	
t_{PZH}	DIR	A or B	2	15	2	10.5	1.5	8.9	ns
t_{PZL}			2	15	2	10.5	1.5	8.9	
t_{PHZ}	\bar{G} and DIR	A or B	2	11	2	7.7	1.5	7.7	ns
t_{PLZ}			2	11	2	7.7	1.5	7.7	
t_{PLH}	CPAB or CPBA	A or B	2	10	2	7	1.5	6.3	ns
t_{PHL}			2	10	2	7	1.5	6.3	
t_{PLH}	SBA or SAB	A or B	2	12	2	8.4	1.5	7	ns
t_{PHL}			2	12	2	8.4	1.5	7	

switching characteristics over operating free-air temperature range (see Figure 2)

PARAMETER	FROM (INPUT)	TO (OUTPUT)	CY74FCT646T		CY74FCT646AT		CY74FCT646CT		UNIT
			MIN	MAX	MIN	MAX	MIN	MAX	
t_{PLH}	A or B	B or A	1.5	9	1.5	6.3	1.5	5.4	ns
t_{PHL}			1.5	9	1.5	6.3	1.5	5.4	
t_{PZH}	DIR	A or B	1.5	14	1.5	9.8	1.5	7.8	ns
t_{PZL}			1.5	14	1.5	9.8	1.5	7.8	
t_{PHZ}	\bar{G} and DIR	A or B	1.5	9	1.5	6.3	1.5	6.3	ns
t_{PLZ}			1.5	9	1.5	6.3	1.5	6.3	
t_{PLH}	CPAB or CPBA	A or B	1.5	9	1.5	6.3	1.5	5.7	ns
t_{PHL}			1.5	9	1.5	6.3	1.5	5.7	
t_{PLH}	SBA or SAB	A or B	1.5	11	1.5	7.7	1.5	6.2	ns
t_{PHL}			1.5	11	1.5	7.7	1.5	6.2	



PARAMETER MEASUREMENT INFORMATION

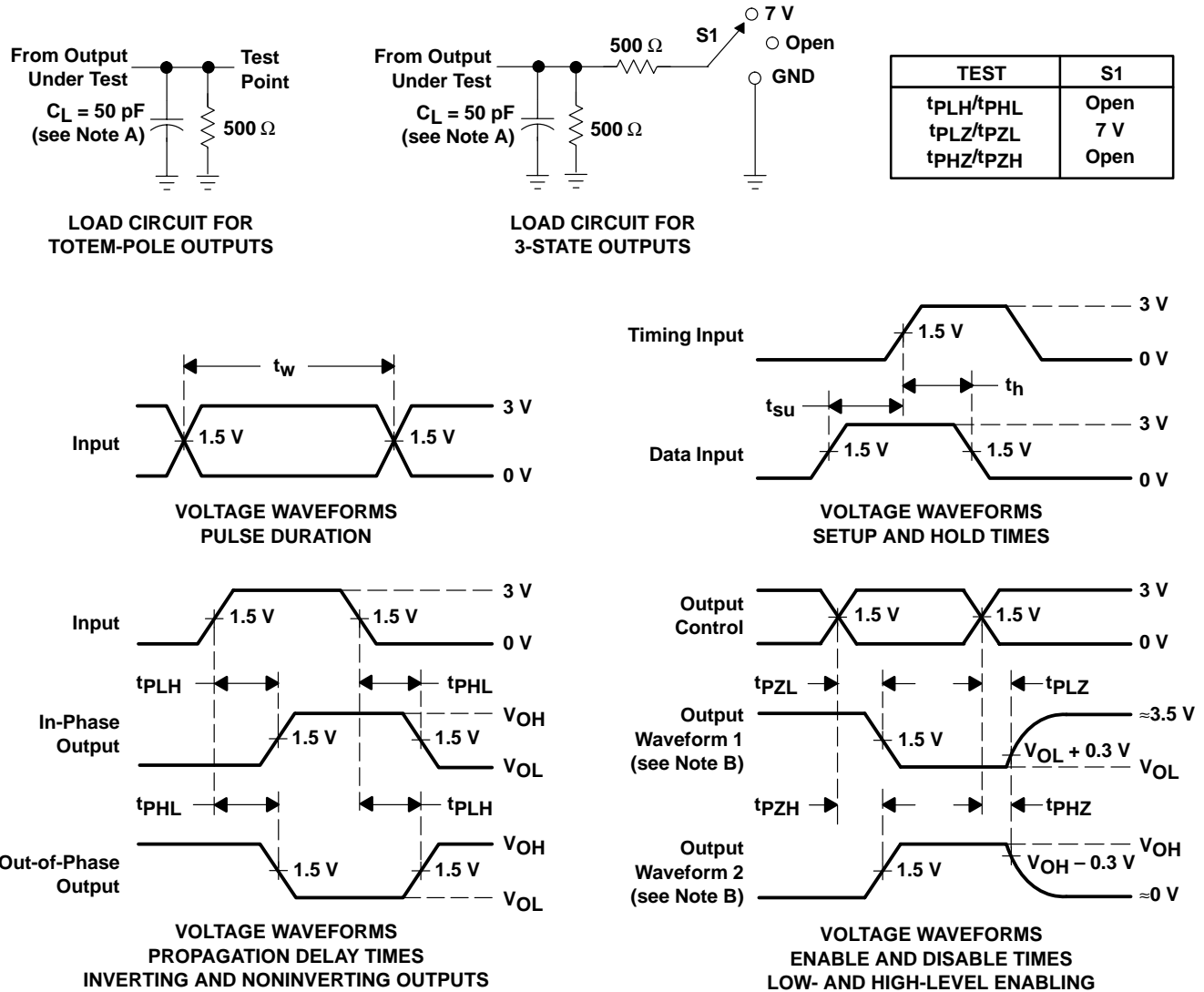

- NOTES: A. C_L includes probe and jig capacitance.
 B. Waveform 1 is for an output with internal conditions such that the output is low except when disabled by the output control. Waveform 2 is for an output with internal conditions such that the output is high except when disabled by the output control.
 C. The outputs are measured one at a time with one input transition per measurement.

Figure 2. Load Circuit and Voltage Waveforms

PACKAGING INFORMATION

Orderable Device	Status ⁽¹⁾	Package Type	Package Drawing	Pins	Package Qty	Eco Plan ⁽²⁾	Lead/ Ball Finish	MSL Peak Temp ⁽³⁾	Samples (Requires Login)
5962-9222301M3A	ACTIVE	LCCC	FK	28	1	TBD	POST-PLATE	N / A for Pkg Type	
5962-9222303M3A	ACTIVE	LCCC	FK	28	1	TBD	Call TI	Call TI	
5962-9222303MLA	ACTIVE	CDIP	JT	24	1	TBD	Call TI	Call TI	
5962-9222305M3A	ACTIVE	LCCC	FK	28	1	TBD	Call TI	Call TI	
CY54FCT646ATDMB	ACTIVE	CDIP	JT	24	1	TBD	A42	N / A for Pkg Type	
CY54FCT646ATLMB	ACTIVE	LCCC	FK	28	1	TBD	POST-PLATE	N / A for Pkg Type	
CY54FCT646CTLMB	ACTIVE	LCCC	FK	28	1	TBD	POST-PLATE	N / A for Pkg Type	
CY74FCT646ATQCT	ACTIVE	SSOP	DBQ	24	2500	Green (RoHS & no Sb/Br)	CU NIPDAU	Level-2-260C-1 YEAR	
CY74FCT646ATQCTE4	ACTIVE	SSOP	DBQ	24	2500	Green (RoHS & no Sb/Br)	CU NIPDAU	Level-2-260C-1 YEAR	
CY74FCT646ATQCTG4	ACTIVE	SSOP	DBQ	24	2500	Green (RoHS & no Sb/Br)	CU NIPDAU	Level-2-260C-1 YEAR	
CY74FCT646ATSOC	ACTIVE	SOIC	DW	24	25	Green (RoHS & no Sb/Br)	CU NIPDAU	Level-1-260C-UNLIM	
CY74FCT646ATSOCE4	ACTIVE	SOIC	DW	24	25	Green (RoHS & no Sb/Br)	CU NIPDAU	Level-1-260C-UNLIM	
CY74FCT646ATSOCG4	ACTIVE	SOIC	DW	24	25	Green (RoHS & no Sb/Br)	CU NIPDAU	Level-1-260C-UNLIM	
CY74FCT646ATSOCT	ACTIVE	SOIC	DW	24	2000	Green (RoHS & no Sb/Br)	CU NIPDAU	Level-1-260C-UNLIM	
CY74FCT646ATSOCTE4	ACTIVE	SOIC	DW	24	2000	Green (RoHS & no Sb/Br)	CU NIPDAU	Level-1-260C-UNLIM	
CY74FCT646ATSOCTG4	ACTIVE	SOIC	DW	24	2000	Green (RoHS & no Sb/Br)	CU NIPDAU	Level-1-260C-UNLIM	
CY74FCT646CTQCT	ACTIVE	SSOP	DBQ	24	2500	Green (RoHS & no Sb/Br)	CU NIPDAU	Level-2-260C-1 YEAR	
CY74FCT646CTQCTE4	ACTIVE	SSOP	DBQ	24	2500	Green (RoHS & no Sb/Br)	CU NIPDAU	Level-2-260C-1 YEAR	
CY74FCT646CTQCTG4	ACTIVE	SSOP	DBQ	24	2500	Green (RoHS & no Sb/Br)	CU NIPDAU	Level-2-260C-1 YEAR	
CY74FCT646CTSOC	ACTIVE	SOIC	DW	24	25	Green (RoHS & no Sb/Br)	CU NIPDAU	Level-1-260C-UNLIM	

Orderable Device	Status ⁽¹⁾	Package Type	Package Drawing	Pins	Package Qty	Eco Plan ⁽²⁾	Lead/ Ball Finish	MSL Peak Temp ⁽³⁾	Samples (Requires Login)
CY74FCT646CTSOCE4	ACTIVE	SOIC	DW	24	25	Green (RoHS & no Sb/Br)	CU NIPDAU	Level-1-260C-UNLIM	
CY74FCT646CTSOCG4	ACTIVE	SOIC	DW	24	25	Green (RoHS & no Sb/Br)	CU NIPDAU	Level-1-260C-UNLIM	
CY74FCT646CTSOCT	ACTIVE	SOIC	DW	24	2000	Green (RoHS & no Sb/Br)	CU NIPDAU	Level-1-260C-UNLIM	
CY74FCT646CTSOCTE4	ACTIVE	SOIC	DW	24	2000	Green (RoHS & no Sb/Br)	CU NIPDAU	Level-1-260C-UNLIM	
CY74FCT646CTSOCTG4	ACTIVE	SOIC	DW	24	2000	Green (RoHS & no Sb/Br)	CU NIPDAU	Level-1-260C-UNLIM	
CY74FCT646TSOC	ACTIVE	SOIC	DW	24	25	Green (RoHS & no Sb/Br)	CU NIPDAU	Level-1-260C-UNLIM	
CY74FCT646TSOCE4	ACTIVE	SOIC	DW	24	25	Green (RoHS & no Sb/Br)	CU NIPDAU	Level-1-260C-UNLIM	
CY74FCT646TSOCG4	ACTIVE	SOIC	DW	24	25	Green (RoHS & no Sb/Br)	CU NIPDAU	Level-1-260C-UNLIM	
CY74FCT646TSOCT	ACTIVE	SOIC	DW	24	2000	Green (RoHS & no Sb/Br)	CU NIPDAU	Level-1-260C-UNLIM	
CY74FCT646TSOCTE4	ACTIVE	SOIC	DW	24	2000	Green (RoHS & no Sb/Br)	CU NIPDAU	Level-1-260C-UNLIM	
CY74FCT646TSOCTG4	ACTIVE	SOIC	DW	24	2000	Green (RoHS & no Sb/Br)	CU NIPDAU	Level-1-260C-UNLIM	

⁽¹⁾ The marketing status values are defined as follows:

ACTIVE: Product device recommended for new designs.

LIFEBUY: TI has announced that the device will be discontinued, and a lifetime-buy period is in effect.

NRND: Not recommended for new designs. Device is in production to support existing customers, but TI does not recommend using this part in a new design.

PREVIEW: Device has been announced but is not in production. Samples may or may not be available.

OBSELETE: TI has discontinued the production of the device.

⁽²⁾ Eco Plan - The planned eco-friendly classification: Pb-Free (RoHS), Pb-Free (RoHS Exempt), or Green (RoHS & no Sb/Br) - please check <http://www.ti.com/productcontent> for the latest availability information and additional product content details.

TBD: The Pb-Free/Green conversion plan has not been defined.

Pb-Free (RoHS): TI's terms "Lead-Free" or "Pb-Free" mean semiconductor products that are compatible with the current RoHS requirements for all 6 substances, including the requirement that lead not exceed 0.1% by weight in homogeneous materials. Where designed to be soldered at high temperatures, TI Pb-Free products are suitable for use in specified lead-free processes.

Pb-Free (RoHS Exempt): This component has a RoHS exemption for either 1) lead-based flip-chip solder bumps used between the die and package, or 2) lead-based die adhesive used between the die and leadframe. The component is otherwise considered Pb-Free (RoHS compatible) as defined above.

Green (RoHS & no Sb/Br): TI defines "Green" to mean Pb-Free (RoHS compatible), and free of Bromine (Br) and Antimony (Sb) based flame retardants (Br or Sb do not exceed 0.1% by weight in homogeneous material)

⁽³⁾ MSL, Peak Temp. -- The Moisture Sensitivity Level rating according to the JEDEC industry standard classifications, and peak solder temperature.

Important Information and Disclaimer: The information provided on this page represents TI's knowledge and belief as of the date that it is provided. TI bases its knowledge and belief on information provided by third parties, and makes no representation or warranty as to the accuracy of such information. Efforts are underway to better integrate information from third parties. TI has taken and continues to take reasonable steps to provide representative and accurate information but may not have conducted destructive testing or chemical analysis on incoming materials and chemicals. TI and TI suppliers consider certain information to be proprietary, and thus CAS numbers and other limited information may not be available for release.

In no event shall TI's liability arising out of such information exceed the total purchase price of the TI part(s) at issue in this document sold by TI to Customer on an annual basis.

TAPE AND REEL INFORMATION
REEL DIMENSIONS

TAPE DIMENSIONS

A0	Dimension designed to accommodate the component width
B0	Dimension designed to accommodate the component length
K0	Dimension designed to accommodate the component thickness
W	Overall width of the carrier tape
P1	Pitch between successive cavity centers

TAPE AND REEL INFORMATION

*All dimensions are nominal

Device	Package Type	Package Drawing	Pins	SPQ	Reel Diameter (mm)	Reel Width W1 (mm)	A0 (mm)	B0 (mm)	K0 (mm)	P1 (mm)	W (mm)	Pin1 Quadrant
CY74FCT646ATQCT	SSOP	DBQ	24	2500	330.0	16.4	6.5	9.0	2.1	8.0	16.0	Q1
CY74FCT646ATSOCT	SOIC	DW	24	2000	330.0	24.4	10.75	15.7	2.7	12.0	24.0	Q1
CY74FCT646CTQCT	SSOP	DBQ	24	2500	330.0	16.4	6.5	9.0	2.1	8.0	16.0	Q1
CY74FCT646CTSOCT	SOIC	DW	24	2000	330.0	24.4	10.75	15.7	2.7	12.0	24.0	Q1
CY74FCT646TSOCT	SOIC	DW	24	2000	330.0	24.4	10.75	15.7	2.7	12.0	24.0	Q1

TAPE AND REEL BOX DIMENSIONS

*All dimensions are nominal

Device	Package Type	Package Drawing	Pins	SPQ	Length (mm)	Width (mm)	Height (mm)
CY74FCT646ATQCT	SSOP	DBQ	24	2500	367.0	367.0	38.0
CY74FCT646ATSOCT	SOIC	DW	24	2000	367.0	367.0	45.0
CY74FCT646CTQCT	SSOP	DBQ	24	2500	367.0	367.0	38.0
CY74FCT646CTSOCT	SOIC	DW	24	2000	367.0	367.0	45.0
CY74FCT646TSOCT	SOIC	DW	24	2000	367.0	367.0	45.0

IMPORTANT NOTICE

Texas Instruments Incorporated and its subsidiaries (TI) reserve the right to make corrections, enhancements, improvements and other changes to its semiconductor products and services per JESD46C and to discontinue any product or service per JESD48B. Buyers should obtain the latest relevant information before placing orders and should verify that such information is current and complete. All semiconductor products (also referred to herein as "components") are sold subject to TI's terms and conditions of sale supplied at the time of order acknowledgment.

TI warrants performance of its components to the specifications applicable at the time of sale, in accordance with the warranty in TI's terms and conditions of sale of semiconductor products. Testing and other quality control techniques are used to the extent TI deems necessary to support this warranty. Except where mandated by applicable law, testing of all parameters of each component is not necessarily performed.

TI assumes no liability for applications assistance or the design of Buyers' products. Buyers are responsible for their products and applications using TI components. To minimize the risks associated with Buyers' products and applications, Buyers should provide adequate design and operating safeguards.

TI does not warrant or represent that any license, either express or implied, is granted under any patent right, copyright, mask work right, or other intellectual property right relating to any combination, machine, or process in which TI components or services are used. Information published by TI regarding third-party products or services does not constitute a license to use such products or services or a warranty or endorsement thereof. Use of such information may require a license from a third party under the patents or other intellectual property of the third party, or a license from TI under the patents or other intellectual property of TI.

Reproduction of significant portions of TI information in TI data books or data sheets is permissible only if reproduction is without alteration and is accompanied by all associated warranties, conditions, limitations, and notices. TI is not responsible or liable for such altered documentation. Information of third parties may be subject to additional restrictions.

Resale of TI components or services with statements different from or beyond the parameters stated by TI for that component or service voids all express and any implied warranties for the associated TI component or service and is an unfair and deceptive business practice. TI is not responsible or liable for any such statements.

Buyer acknowledges and agrees that it is solely responsible for compliance with all legal, regulatory and safety-related requirements concerning its products, and any use of TI components in its applications, notwithstanding any applications-related information or support that may be provided by TI. Buyer represents and agrees that it has all the necessary expertise to create and implement safeguards which anticipate dangerous consequences of failures, monitor failures and their consequences, lessen the likelihood of failures that might cause harm and take appropriate remedial actions. Buyer will fully indemnify TI and its representatives against any damages arising out of the use of any TI components in safety-critical applications.

In some cases, TI components may be promoted specifically to facilitate safety-related applications. With such components, TI's goal is to help enable customers to design and create their own end-product solutions that meet applicable functional safety standards and requirements. Nonetheless, such components are subject to these terms.

No TI components are authorized for use in FDA Class III (or similar life-critical medical equipment) unless authorized officers of the parties have executed a special agreement specifically governing such use.

Only those TI components which TI has specifically designated as military grade or "enhanced plastic" are designed and intended for use in military/aerospace applications or environments. Buyer acknowledges and agrees that any military or aerospace use of TI components which have **not** been so designated is solely at the Buyer's risk, and that Buyer is solely responsible for compliance with all legal and regulatory requirements in connection with such use.

TI has specifically designated certain components which meet ISO/TS16949 requirements, mainly for automotive use. Components which have not been so designated are neither designed nor intended for automotive use; and TI will not be responsible for any failure of such components to meet such requirements.

Products

Audio	www.ti.com/audio
Amplifiers	amplifier.ti.com
Data Converters	dataconverter.ti.com
DLP® Products	www.dlp.com
DSP	dsp.ti.com
Clocks and Timers	www.ti.com/clocks
Interface	interface.ti.com
Logic	logic.ti.com
Power Mgmt	power.ti.com
Microcontrollers	microcontroller.ti.com
RFID	www.ti-rfid.com
OMAP Mobile Processors	www.ti.com/omap
Wireless Connectivity	www.ti.com/wirelessconnectivity

Applications

Automotive and Transportation	www.ti.com/automotive
Communications and Telecom	www.ti.com/communications
Computers and Peripherals	www.ti.com/computers
Consumer Electronics	www.ti.com/consumer-apps
Energy and Lighting	www.ti.com/energy
Industrial	www.ti.com/industrial
Medical	www.ti.com/medical
Security	www.ti.com/security
Space, Avionics and Defense	www.ti.com/space-avionics-defense
Video and Imaging	www.ti.com/video

TI E2E Community e2e.ti.com