



INA145

For most current data sheet and other product information, visit [www.burr-brown.com](http://www.burr-brown.com)

# Programmable Gain DIFFERENCE AMPLIFIER

## FEATURES

- DIFFERENTIAL GAIN = 1V/V TO 1000V/V:  
Set with External Resistors
- LOW QUIESCENT CURRENT: 570µA
- WIDE SUPPLY RANGE:  
Single Supply: 4.5V to 36V  
Dual Supplies: ±2.25V to ±18V
- HIGH COMMON-MODE VOLTAGE:  
+8V at  $V_S = +5V$   
±28V at  $V_S = ±15V$
- LOW GAIN ERROR: 0.01%
- HIGH CMR: 86dB
- SO-8 PACKAGE

## DESCRIPTION

The INA145 is a precision, unity-gain difference amplifier consisting of a precision op amp and on-chip precision resistor network. Two external resistors set the gain from 1V/V to 1000V/V. The input common-mode voltage range extends beyond the positive and negative rails.

On-chip precision resistors are laser-trimmed to achieve accurate gain and high common-mode rejection. Excellent TCR tracking of these resistors assures continued high precision over temperature.

The INA145 is available in the SO-8 surface-mount package specified for the extended industrial temperature range, -40°C to +85°C.

## APPLICATIONS

- CURRENT SHUNT MEASUREMENTS
- SENSOR AMPLIFIER
- DIFFERENTIAL LINE RECEIVER
- BATTERY POWERED SYSTEMS

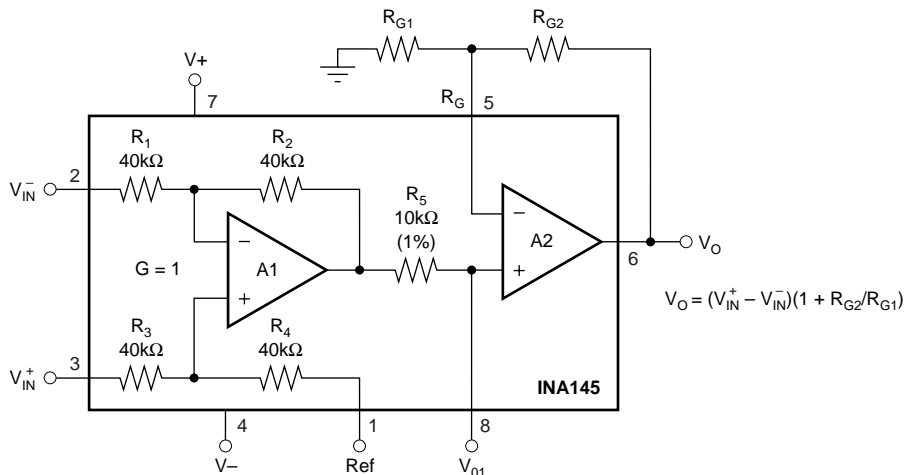

International Airport Industrial Park • Mailing Address: PO Box 11400, Tucson, AZ 85734 • Street Address: 6730 S. Tucson Blvd., Tucson, AZ 85706 • Tel: (520) 746-1111  
Twx: 910-952-1111 • Internet: <http://www.burr-brown.com/> • Cable: BBRCORP • Telex: 066-6491 • FAX: (520) 889-1510 • Immediate Product Info: (800) 548-6132

# SPECIFICATIONS: $V_S = \pm 2.25V$ to $\pm 18V$

**Boldface** limits apply over the specified temperature range,  $T_A = -40^\circ C$  to  $+85^\circ C$

At  $T_A = +25^\circ C$ ,  $G = 1$ ,  $R_L = 10k\Omega$  connected to ground and ref pin connected to ground unless otherwise noted.

PARAMETER	CONDITION	INA145UA			UNITS
		MIN	TYP	MAX	
<b>OFFSET VOLTAGE, <math>V_O</math></b> Input Offset Voltage <b>vs Temperature</b> vs Power Supply vs Time Offset Voltage, $V_{O1}$	RTI <sup>(1, 2)</sup> $V_{CM} = V_O = 0V$		$\pm 0.2$	$\pm 1$	mV
		<b>See Typical Curve</b>			
	RTI <sup>(1, 2)</sup>		$\pm 20$	$\pm 60$	$\mu V/V$
			$\pm 0.3$		$\mu V/mo$
			$\pm 0.4$	mV	
<b>INPUT VOLTAGE RANGE</b> Common-Mode Voltage Range Common-Mode Rejection <b>Over Temperature</b>	$(V_{IN+}) - (V_{IN-}) = 0V$ , $V_O = 0V$ $V_{CM} = 2(V-) \text{ to } 2(V+) - 2V$ , $R_S = 0\Omega$ $V_S = \pm 15V$	2(V-)		2(V+) - 2	V
		76	86		dB
		<b>70</b>	<b>80</b>		dB
<b>INPUT BIAS CURRENT<sup>(2)</sup></b> Bias Current Offset Current	$V_{CM} = V_S/2$		$\pm 50$		nA
			$\pm 5$		nA
<b>INPUT IMPEDANCE</b> Differential (non-inverting input) Differential (inverting input) Common-Mode			80		k $\Omega$
			27		k $\Omega$
			40		k $\Omega$
<b>NOISE</b> Voltage Noise, $f = 0.1Hz$ to $10Hz$ Voltage Noise Density, $f = 1kHz$	RTI <sup>(1, 3)</sup>		2		$\mu Vp-p$
				90	nV/ $\sqrt{Hz}$
<b>GAIN</b> Gain Equation Initial <sup>(1)</sup> Gain Error <b>vs Temperature</b>  <b>vs Temperature</b> Nonlinearity	$R_L = 100k\Omega$ , $V_O = (V-)+0.15$ to $(V+)-1$ , $G = 1$ <b><math>R_L = 100k\Omega</math>, <math>V_O = (V-)+0.25</math> to <math>(V+)-1</math>, <math>G = 1</math></b> $R_L = 10k\Omega$ , $V_O = (V-)+0.3$ to $(V+)-1.25$ , $G = 1$ <b><math>R_L = 10k\Omega</math>, <math>V_O = (V-)+0.5</math> to <math>(V+)-1.25</math>, <math>G = 1</math></b> $R_L = 10k\Omega$ , $V_O = (V-)+0.3$ to $(V+)-1.25$ , $G = 1$		$G = 1$ to $1000$ $G = 1 + R_{G2}/R_{G1}$		V/V
			1		V/V
			$\pm 0.01$	$\pm 0.1$	%
			$\pm 2$	$\pm 10$	ppm/ $^\circ C$
			$\pm 0.01$	$\pm 0.1$	%
		$\pm 2$	$\pm 10$	ppm/ $^\circ C$	
		$\pm 0.0002$	$\pm 0.005$	% of FS	
<b>FREQUENCY RESPONSE</b> Small Signal Bandwidth  Slew Rate Settling Time, 0.1% 0.01% Overload Recovery	$G = 1$ $G = 10$  $G = 1$ , 10V Step $G = 1$ , 10V Step 50% Input Overload		500		kHz
			50		kHz
			0.45		V/ $\mu s$
			40		$\mu s$
			90		$\mu s$
			40		$\mu s$
<b>OUTPUT, <math>V_O</math></b> Voltage Output <b>Over Temperature</b>  <b>Over Temperature</b> Short-Circuit Current Capacitive Load	$R_L = 100k\Omega$ , $G = 1$ <b><math>R_L = 100k\Omega</math>, <math>G = 1</math></b> $R_L = 10k\Omega$ , $G = 1$ <b><math>R_L = 10k\Omega</math>, <math>G = 1</math></b> Continuous to Common Stable Operation	(V-) + 0.15		(V+) - 1	V
		<b>(V-) + 0.25</b>		<b>(V+) - 1</b>	V
		(V-) + 0.3		(V+) - 1.25	V
		<b>(V-) + 0.5</b>		<b>(V+) - 1.25</b>	V
			$\pm 15$		mA
	1000		pF		
<b>POWER SUPPLY</b> Specified Voltage Range, Dual Supplies Operating Voltage Range Quiescent Current <b>Over Temperature</b>	$V_{IN} = 0$ , $I_O = 0$	$\pm 2.25$		$\pm 18$	V
		$\pm 1.35$		$\pm 18$	V
			$\pm 570$	$\pm 700$	$\mu A$
				<b><math>\pm 800</math></b>	$\mu A$
<b>TEMPERATURE RANGE</b> Specified Range Operating Range Storage Range Thermal Resistance	$\theta_{JA}$	-40		+85	$^\circ C$
		-55		+125	$^\circ C$
		-55		+125	$^\circ C$
			150		$^\circ C/W$

NOTES: (1) Referred to input pins ( $V_{IN+}$  and  $V_{IN-}$ ), Gain = 1V/V. Specified with 10k $\Omega$  in feedback of A2. (2) Input offset voltage specification includes effects of amplifier's input bias and offset currents. (3) Includes effects of input bias current noise and thermal noise contribution of resistor network.

The information provided herein is believed to be reliable; however, BURR-BROWN assumes no responsibility for inaccuracies or omissions. BURR-BROWN assumes no responsibility for the use of this information, and all use of such information shall be entirely at the user's own risk. Prices and specifications are subject to change without notice. No patent rights or licenses to any of the circuits described herein are implied or granted to any third party. BURR-BROWN does not authorize or warrant any BURR-BROWN product for use in life support devices and/or systems.

# SPECIFICATIONS: $V_S = +5V$ Single Supply

**Boldface** limits apply over the specified temperature range,  $T_A = -40^\circ\text{C}$  to  $+85^\circ\text{C}$

At  $T_A = +25^\circ\text{C}$ ,  $G = 1$ ,  $R_L = 10\text{k}\Omega$  connected to ground and ref pin connected to 2.5V unless otherwise noted.

PARAMETER	CONDITION	INA145UA			UNITS	
		MIN	TYP	MAX		
<b>OFFSET VOLTAGE, <math>V_O</math></b> Input Offset Voltage $V_{OS}$ <b>vs Temperature</b> $\Delta V_{OS}/\Delta T$ vs Power Supply Rejection Ratio PSRR vs Time Offset Voltage, $V_{O1}$	RTI <sup>(1, 2)</sup> $V_{CM} = V_O = 2.5V$		$\pm 0.35$	$\pm 1$	mV	
	$V_S = \pm 1.35V$ to $\pm 18V$		<b>See Typical Curve</b>			
			$\pm 20$	$\pm 60$	$\mu\text{V}/^\circ\text{C}$	
		RTI <sup>(1, 2)</sup>		$\pm 0.3$		$\mu\text{V}/\text{mo}$
			$\pm 0.55$		mV	
<b>INPUT VOLTAGE RANGE</b> Common-Mode Voltage Range <sup>(3)</sup> $V_{CM}$ Common-Mode Rejection Ratio CMRR <b>Over Temperature</b>	$V_{IN+} - V_{IN-} = 0V$ , $V_O = 2.5V$ $V_{CM} = -2.5V$ to $+5.5V$ , $R_S = 0\Omega$	-2.5		5.5	V	
		76	86 <b>80</b>		dB dB	
<b>INPUT BIAS CURRENT<sup>(2)</sup></b> Bias Current $I_B$ Offset Current $I_{OS}$			$\pm 50$		nA	
			$\pm 5$		nA	
<b>INPUT IMPEDANCE</b> Differential (non-inverting input) Differential (inverting input) Common-Mode			80		k $\Omega$	
			27		k $\Omega$	
			40		k $\Omega$	
<b>NOISE</b> Voltage Noise, $f = 0.1\text{Hz}$ to $10\text{Hz}$ Voltage Noise Density, $f = 1\text{kHz}$ $e_n$	RTI <sup>(1, 4)</sup>		2		$\mu\text{Vp-p}$	
			90		$\text{nV}/\sqrt{\text{Hz}}$	
<b>GAIN</b> Gain Equation Initial <sup>(1)</sup> Gain Error <b>vs Temperature</b>  <b>vs Temperature</b> Nonlinearity	$R_L = 100\text{k}\Omega$ , $V_O = 0.15V$ to $4V$ , $G = 1$ <b><math>R_L = 100\text{k}\Omega</math>, <math>V_O = 0.25V</math> to <math>4V</math>, <math>G = 1</math></b> $R_L = 10\text{k}\Omega$ , $V_O = 0.3V$ to $3.75V$ , $G = 1$ <b><math>R_L = 10\text{k}\Omega</math>, <math>V_O = 0.5V</math> to <math>3.75V</math>, <math>G = 1</math></b> $R_L = 10\text{k}\Omega$ , $V_O = +0.3$ to $+3.75$ , $G = 1$		$G = 1$ to $1000$ $G = 1 + R_{G2}/R_{G1}$		V/V	
			1		V/V	
			$\pm 0.01$	$\pm 0.1$	%	
			<b><math>\pm 2</math></b>	<b><math>\pm 10</math></b>	ppm/ $^\circ\text{C}$	
			$\pm 0.01$	$\pm 0.1$	%	
			<b><math>\pm 2</math></b>	<b><math>\pm 10</math></b>	ppm/ $^\circ\text{C}$	
		$\pm 0.001$	$\pm 0.005$	% of FS		
<b>FREQUENCY RESPONSE</b> Small Signal Bandwidth  Slew Rate Settling Time, 0.1% 0.01% Overload Recovery	$G = 0.1$		500		kHz	
	$G = 1$		50		kHz	
	$G = 1$ , 10V Step		0.45		V/ $\mu\text{s}$	
	$G = 1$ , 10V Step		40		$\mu\text{s}$	
	50% Input Overload			90		$\mu\text{s}$
				40		$\mu\text{s}$
<b>OUTPUT, <math>V_O</math></b> Voltage Output <b>Over Temperature</b>  <b>Over Temperature</b> Short-Circuit Current Capacitive Load	$R_L = 100\text{k}\Omega$ , $G = 1$ <b><math>R_L = 100\text{k}\Omega</math>, <math>G = 1</math></b> $R_L = 10\text{k}\Omega$ , $G = 1$ <b><math>R_L = 10\text{k}\Omega</math>, <math>G = 1</math></b> Continuous to Common Stable Operation	0.15		4	V	
		<b>0.25</b>		<b>4</b>	V	
		0.3		3.75	V	
		<b>0.5</b>		<b>3.75</b>	V	
				$\pm 15$		mA
				1000		pF
<b>POWER SUPPLY</b> Specified Voltage Range, Single Supply Operating Voltage Range Quiescent Current <b>Over Temperature</b>	$V_{IN} = 0$ , $I_O = 0$	+4.5		+36	V	
		+2.7		+36	V	
			550	700	$\mu\text{A}$	
				<b>800</b>	$\mu\text{A}$	
<b>TEMPERATURE RANGE</b> Specified Range Operating Range Storage Range Thermal Resistance $\theta_{JA}$		-40		+85	$^\circ\text{C}$	
		-55		+125	$^\circ\text{C}$	
		-55		+125	$^\circ\text{C}$	
			150		$^\circ\text{C}/W$	

NOTES: (1) Referred to input pins ( $V_{IN+}$  and  $V_{IN-}$ ), Gain = 1V/V. Specified with 10k $\Omega$  in feedback of A2. (2) Input offset voltage specification includes effects of amplifier's input bias and offset currents. (3) Common-mode voltage range with single supply is  $2(V+) - 2V - V_{REF}$  to  $-V_{REF}$ . (4) Includes effects of input current noise and thermal noise contribution of resistor network.

# AMPLIFIER A1, A2 PERFORMANCE

**Boldface** limits apply over the specified temperature range,  $T_A = -40^{\circ}\text{C}$  to  $+85^{\circ}\text{C}$

At  $T_A = +25^{\circ}\text{C}$ ,  $G = 1$ ,  $R_L = 10\text{k}\Omega$  connected to ground and ref pin connected to ground unless otherwise noted.

PARAMETER	CONDITION	INA145UA			UNITS
		MIN	TYP	MAX	
<b>OFFSET VOLTAGE, <math>V_O</math></b> Input Offset Voltage <b>vs Temperature</b>	$RTI^{(1,2)}$ $V_S = \pm 15\text{V}$ , $V_{CM} = V_O = 0\text{V}$		$\pm 0.5$ $\pm 1$		mV $\mu\text{V}/^{\circ}\text{C}$
<b>INPUT VOLTAGE RANGE</b> Common-Mode Voltage Range Common-Mode Rejection Ratio	$V_{IN+} - V_{IN-} = 0\text{V}$ , $V_O = 0\text{V}$ $V_{CM} = (V-) \text{ to } (V+) - 1$		$(V-) \text{ to } (V+) - 1$ 90		V dB
<b>OPEN-LOOP GAIN</b> Open Loop Gain			110		dB
<b>INPUT BIAS CURRENT<sup>(2)</sup></b> Bias Current Offset Current			$\pm 50$ $\pm 5$		nA nA
<b>RESISTOR AT A1 OUTPUT, <math>V_{O1}</math></b> Initial Error Temperature Drift Coefficient			10 $\pm 0.2$ $\pm 50$		k $\Omega$ % ppm/ $^{\circ}\text{C}$

## PIN CONFIGURATION

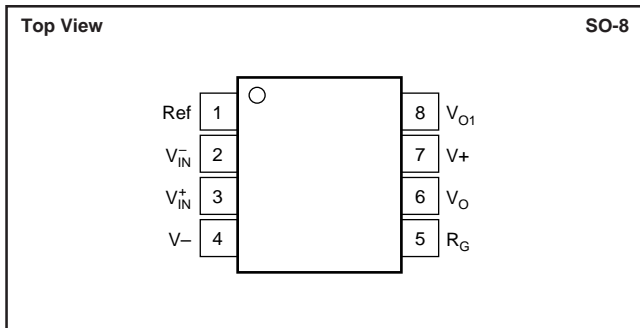

## ELECTROSTATIC DISCHARGE SENSITIVITY

This integrated circuit can be damaged by ESD. Burr-Brown recommends that all integrated circuits be handled with appropriate precautions. Failure to observe proper handling and installation procedures can cause damage.

ESD damage can range from subtle performance degradation to complete device failure. Precision integrated circuits may be more susceptible to damage because very small parametric changes could cause the device not to meet its published specifications.

## ABSOLUTE MAXIMUM RATINGS<sup>(1)</sup>

Supply Voltage, $V+$ to $V-$	36V
Signal Input Terminals, Voltage	$\pm 80\text{V}$
Current	$\pm 1\text{mA}$
Output Short Circuit (to ground)	Continuous
Operating Temperature	$-55^{\circ}\text{C}$ to $+125^{\circ}\text{C}$
Storage Temperature	$-55^{\circ}\text{C}$ to $+150^{\circ}\text{C}$
Junction Temperature	$+150^{\circ}\text{C}$
Lead Temperature (soldering, 10s)	$+240^{\circ}\text{C}$

NOTE: (1) Stresses above these ratings may cause permanent damage. Exposure to absolute maximum conditions for extended periods may degrade device reliability.

## PACKAGE/ORDERING INFORMATION

PRODUCT	PACKAGE	PACKAGE DRAWING NUMBER	SPECIFIED TEMPERATURE RANGE	PACKAGE MARKING	ORDERING NUMBER <sup>(1)</sup>	TRANSPORT MEDIA
INA145UA "	SO-8 "	182 "	$-40^{\circ}\text{C}$ to $+85^{\circ}\text{C}$ "	INA145UA "	INA145UA INA145UA/2K5	Rails Tape and Reel

NOTE: (1) Models with a slash (/) are available only in Tape and Reel in the quantities indicated (e.g., /2K5 indicates 2500 devices per reel). Ordering 2500 pieces of "INA145UA/2K5" will get a single 2500-piece Tape and Reel.

# TYPICAL PERFORMANCE CURVES

At  $T_A = +25^\circ\text{C}$ ,  $V_S = \pm 15\text{V}$ ,  $G = 1$ ,  $R_L = 10\text{k}\Omega$  connected to ground and Ref pin connected to ground, unless otherwise noted.

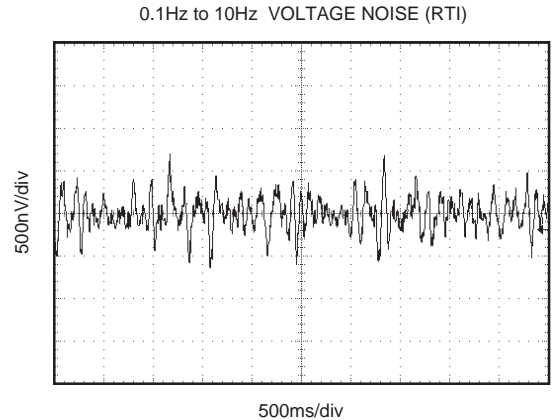
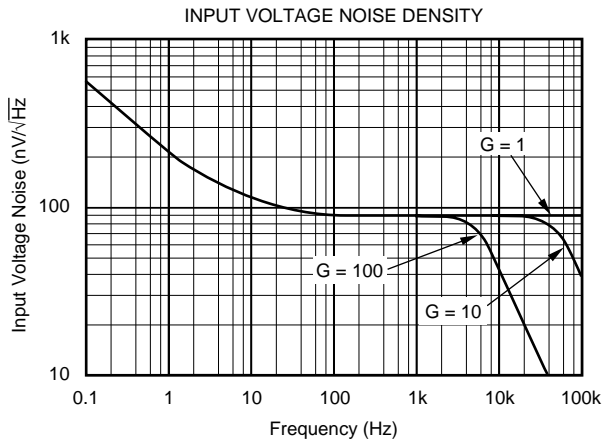
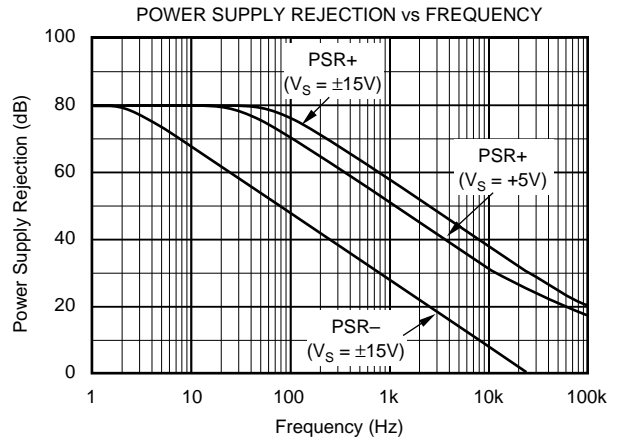
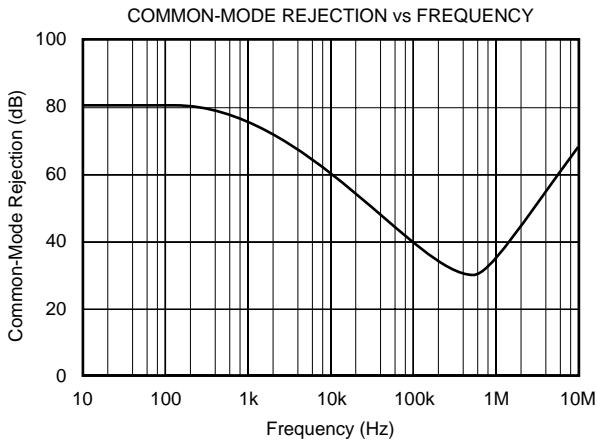
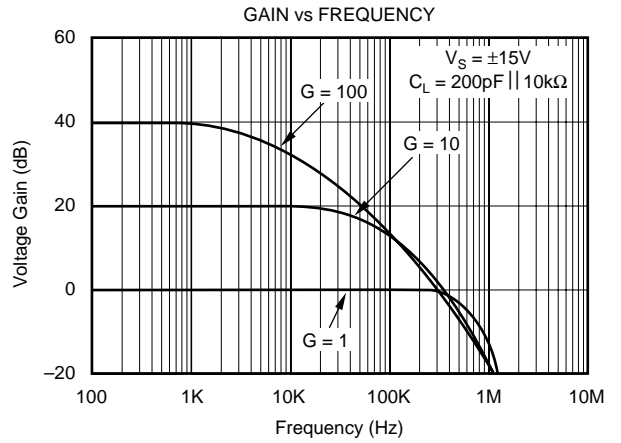
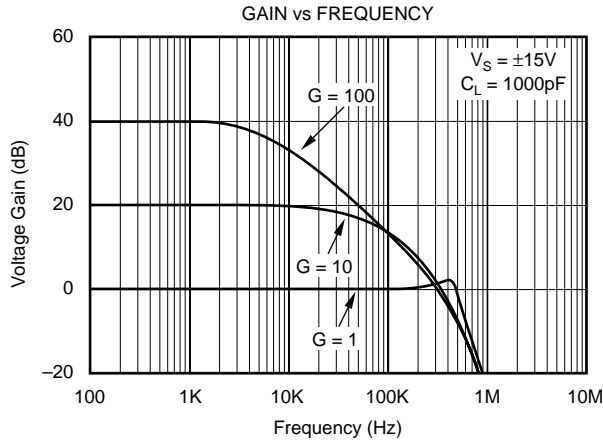

# TYPICAL PERFORMANCE CURVES (Cont.)

At  $T_A = +25^\circ\text{C}$ ,  $V_S = \pm 15\text{V}$ ,  $G = 1$ ,  $R_L = 10\text{k}\Omega$  connected to ground and Ref pin connected to ground, unless otherwise noted.

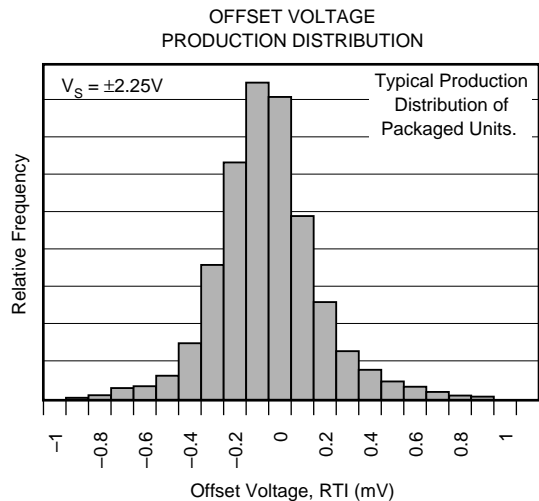
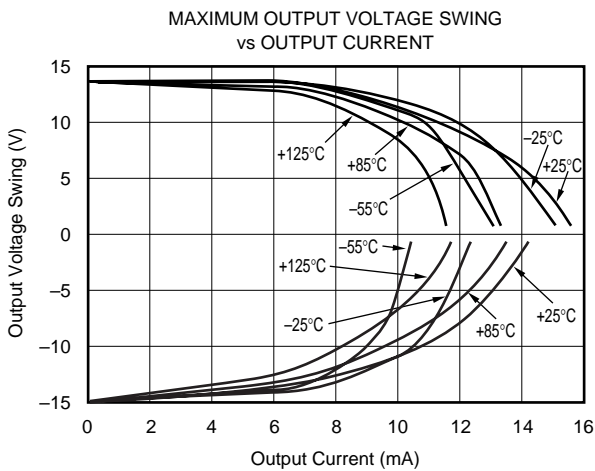
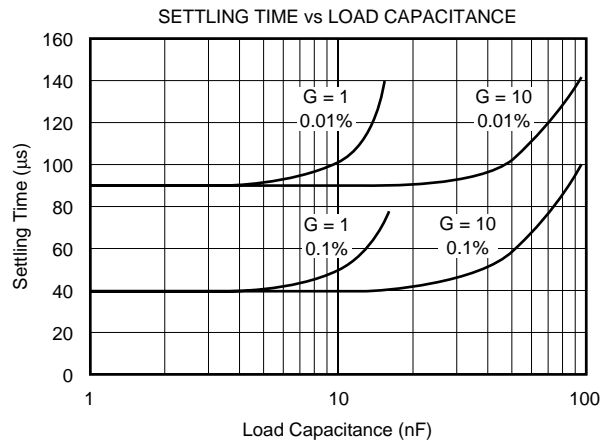
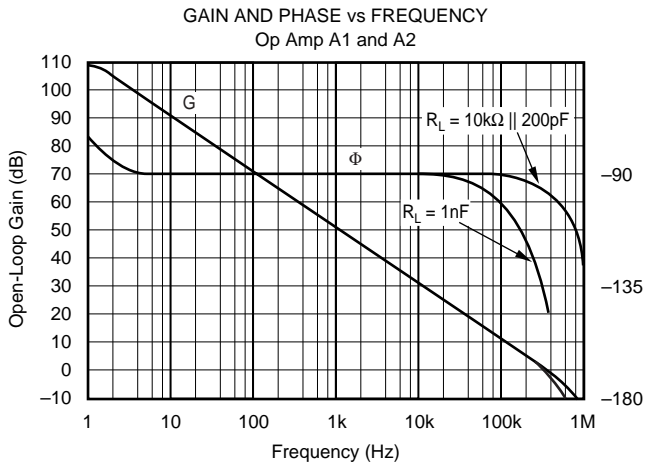
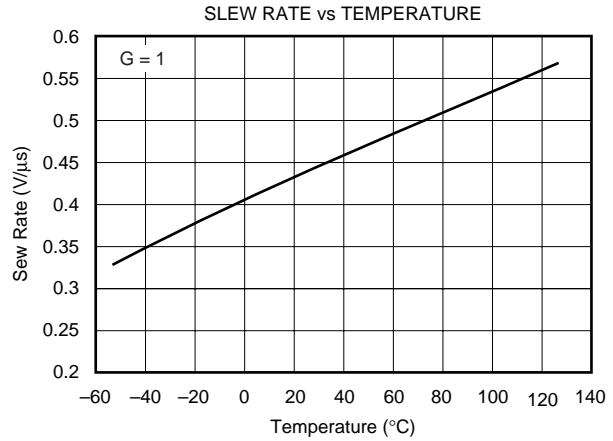
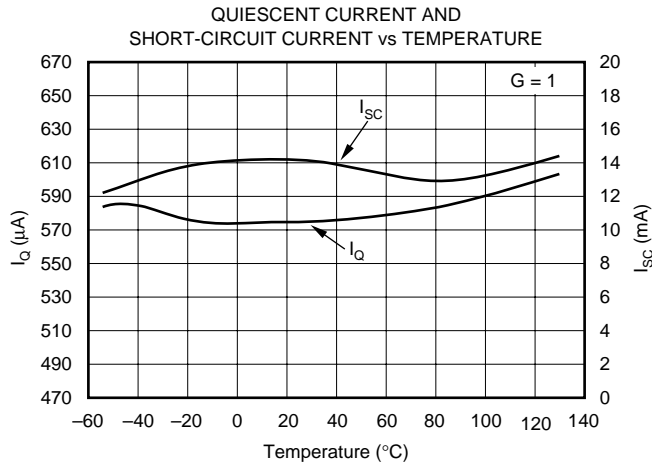

# TYPICAL PERFORMANCE CURVES (Cont.)

At  $T_A = +25^\circ\text{C}$ ,  $V_S = \pm 15\text{V}$ ,  $G = 1$ ,  $R_L = 10\text{k}\Omega$  connected to ground and Ref pin connected to ground, unless otherwise noted.

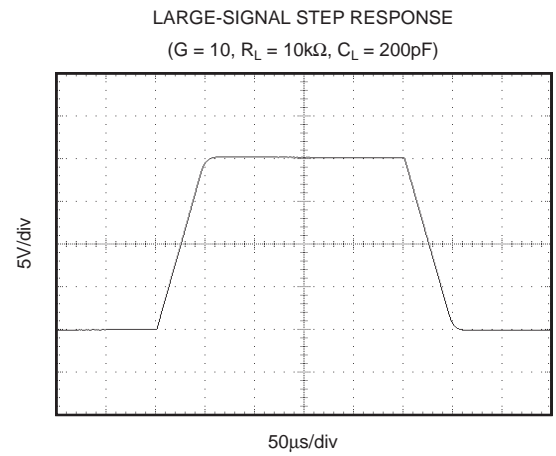
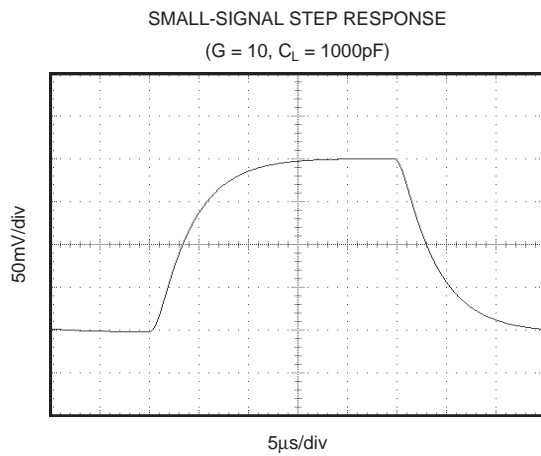
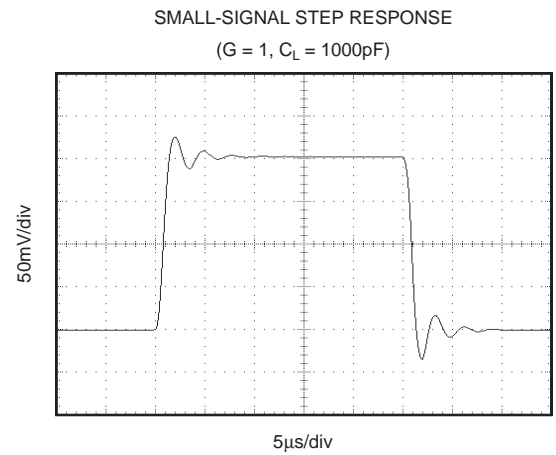
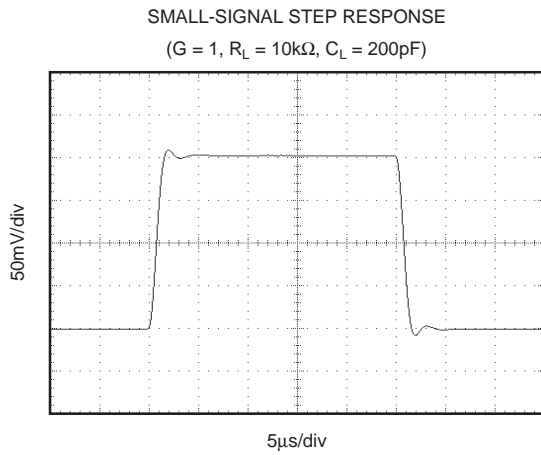
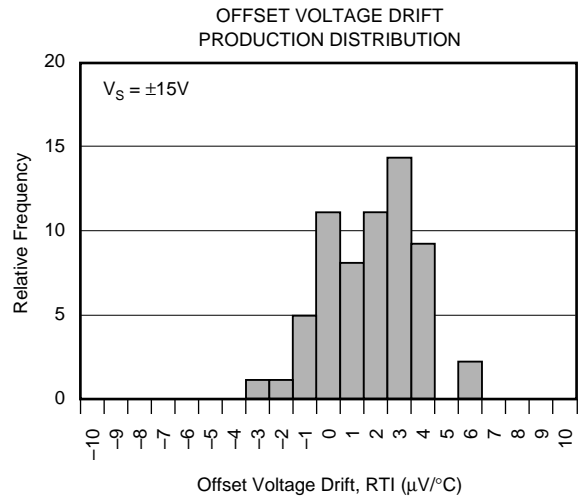
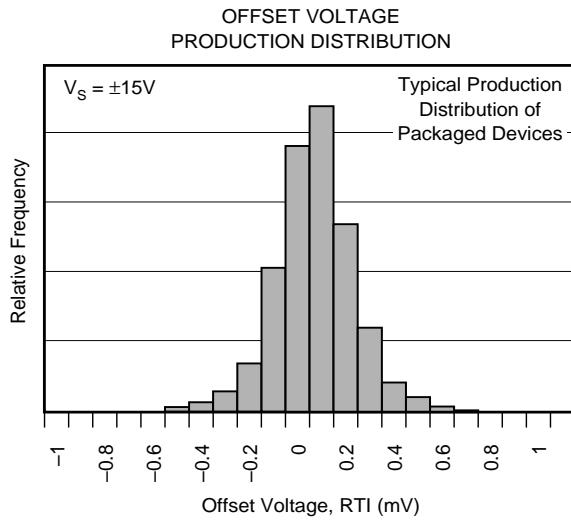

# APPLICATION INFORMATION

The INA145 is a programmable gain difference amplifier consisting of a gain of 1 difference amplifier and a programmable-gain output buffer stage. Basic circuit connections are shown in Figure 1. Power supply bypass capacitors should be connected close to pins 4 and 7, as shown. The amplifier is programmable in the range of  $G = 1$  to  $G = 1000$  with two external resistors.

The output of A1 is connected to the noninverting input of A2 through a  $10\text{k}\Omega$  resistor which is trimmed to  $\pm 1\%$  absolute accuracy. The A2 input is available for applications such as a filter or a precision current source. See application figures for examples.

## OPERATING VOLTAGE

The INA145 is fully specified for supply voltages from  $\pm 2.25\text{V}$  to  $\pm 18\text{V}$ , with key parameters guaranteed over the temperature range  $-40^\circ\text{C}$  to  $+85^\circ\text{C}$ . The INA145 can be operated with single or dual supplies, with excellent performance. Parameters that vary significantly with operating voltage, load conditions, or temperature are shown in the typical performance curves.

## SETTING THE GAIN

The gain of the INA145 is set by using two external resistors,  $R_{G1}$  and  $R_{G2}$ , according to the equation:

$$G = 1 + R_{G2}/R_{G1}$$

For a total gain of 1, A2 is connected as a buffer amplifier with no  $R_{G1}$ . A feedback resistor,  $R_{G2} = 10\text{k}\Omega$ , should be used in the buffer connection. This provides bias current cancellation (in combination with internal  $R_5$ ) to assure specified offset voltage performance. Commonly used values are shown in the table of Figure 1. Resistor values for other gains should be chosen to provide a  $10\text{k}\Omega$  parallel resistance.

## COMMON-MODE RANGE

The input resistors of the INA145 provides an input common-mode range that extends well beyond the power supply rails. Exact range depends on the power supply voltage and the voltage applied to the Ref terminal (pin 1). To assure proper operation, the voltage at the non-inverting input of A1 (an internal node) must be within its linear operating range. Its voltage is determined by the simple 1:1 voltage divider between pin 3 and pin 1. This voltage must be between  $V_-$  and  $(V_+) - 1\text{V}$ .

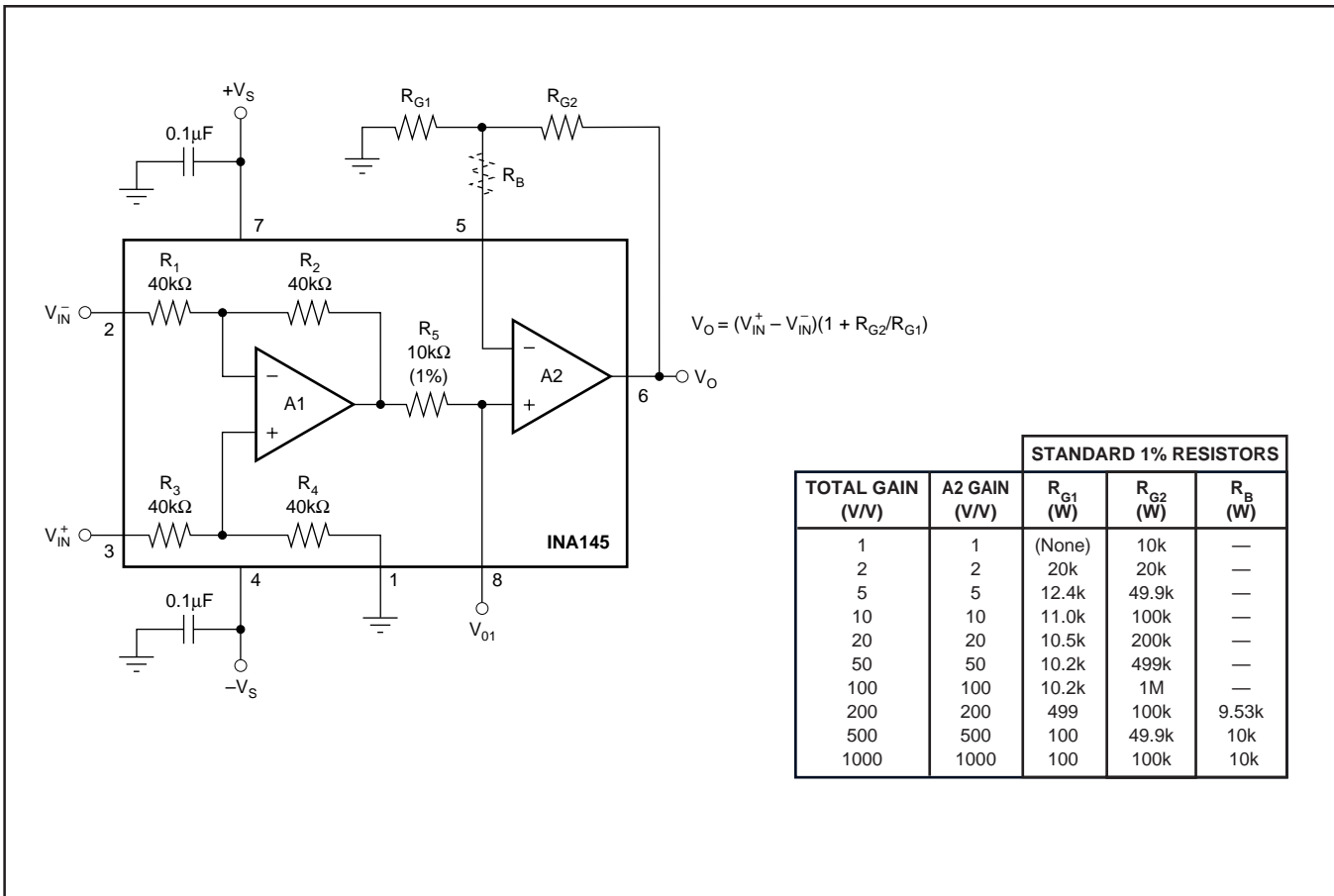

FIGURE 1. Basic Circuit Connections.

## OFFSET TRIM

The INA145 is laser-trimmed for low offset voltage and drift. Most applications require no external offset adjustment. Figure 2 shows an optional circuit for trimming the offset voltage. A voltage applied to the Ref terminal will be summed with the output signal. This can be used to null offset voltage. To maintain good common-mode rejection, the source impedance of a signal applied to the Ref terminal should be less than  $10\Omega$  and a resistor added to the positive input terminal should be 10 times that, or  $100\Omega$ . Alternatively, the trim voltage can be buffered with an op amp such as the OPA277.

## INPUT IMPEDANCE

The input impedance of the INA145 is determined by the input resistor network and is approximately  $40k\Omega$ . The source impedance at the two input terminals must be nearly equal to maintain good common-mode rejection. A  $5\Omega$  mismatch in impedance between the two inputs will cause the typical common-mode rejection to be degraded to approximately  $72\text{dB}$ . Figure 7 shows a common application measuring power supply current through a shunt resistor. The source impedance of the shunt resistor,  $R_S$ , is balanced by an equal compensation resistor,  $R_C$ .

Source impedances greater than  $300\Omega$  are not recommended, even if they are perfectly matched. Internal resistors are laser trimmed for accurate ratios, not to absolute values. Adding equal resistors greater than  $300\Omega$  can cause a mismatch in the total resistor ratios, degrading CMR.

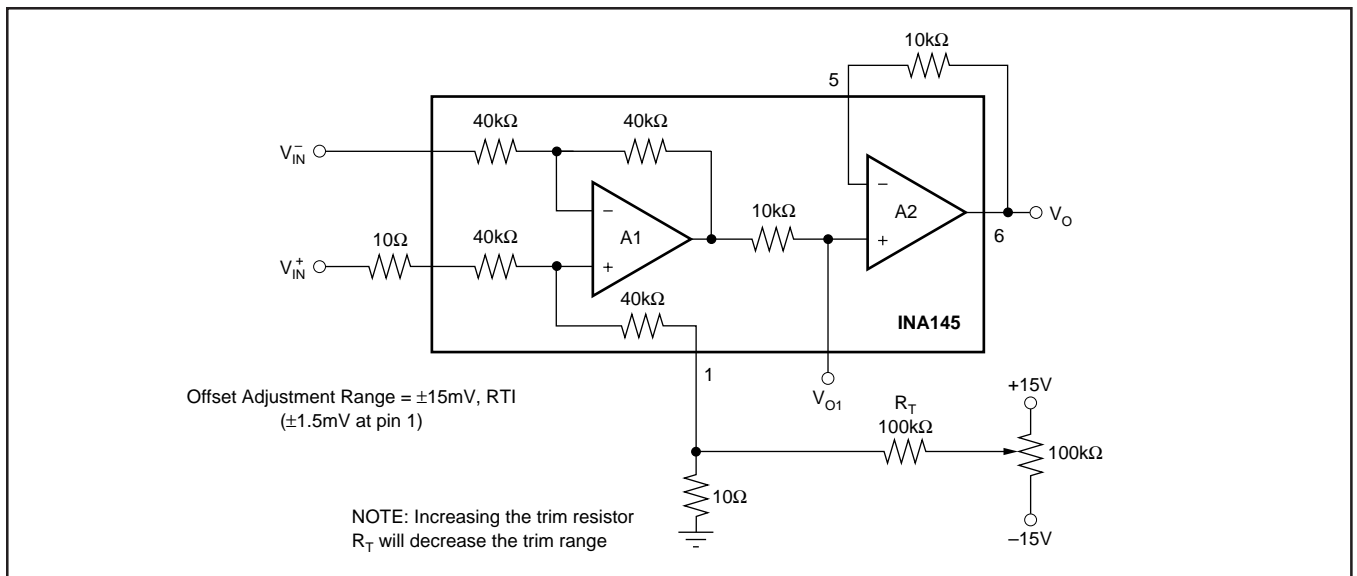

FIGURE 2. Optional Offset Trim Circuit.

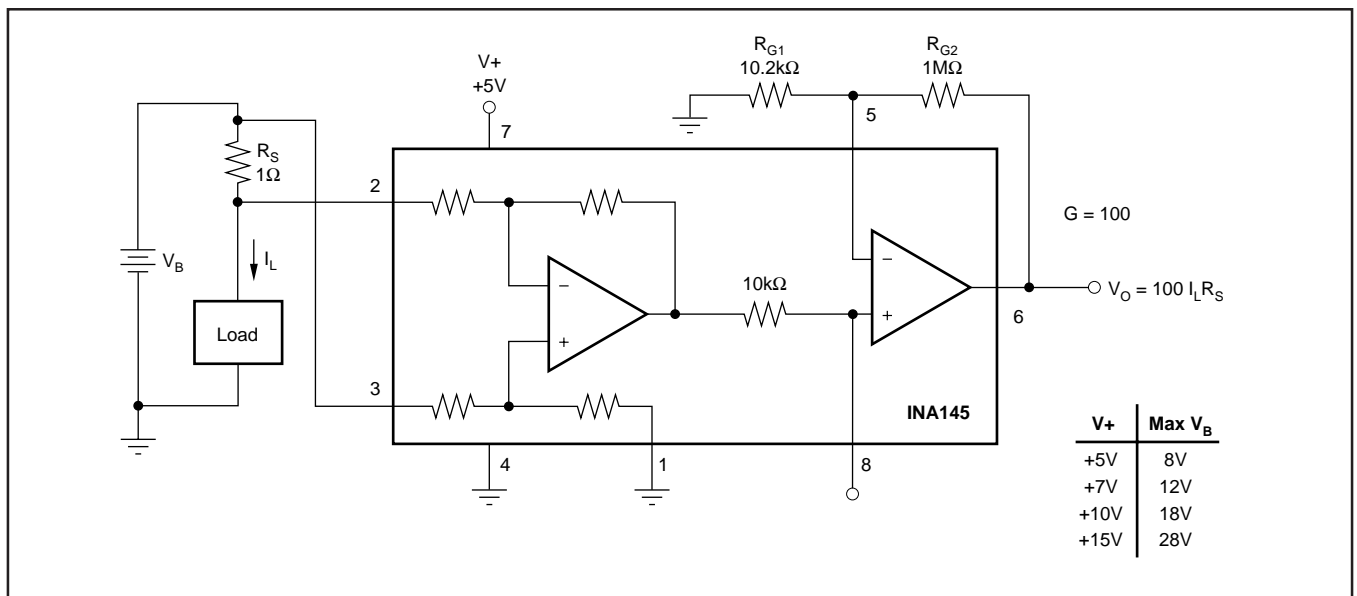

FIGURE 3. Measuring Current with Shunt Resistor.

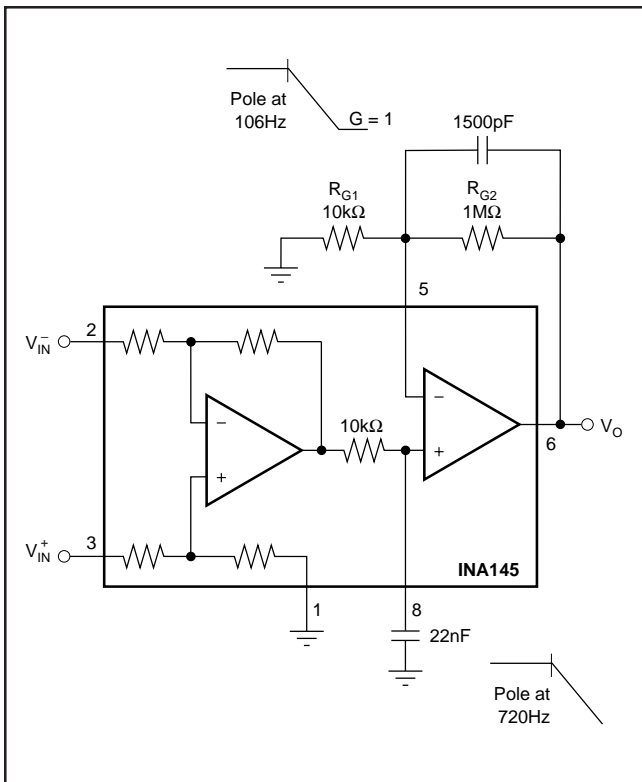

FIGURE 4. Noise Filtering.

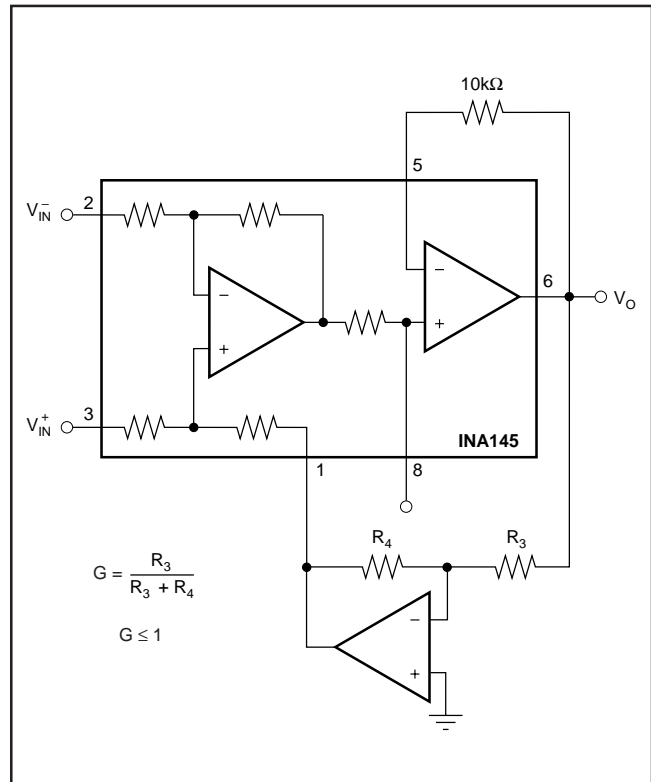

FIGURE 5. Creating Gains Less Than Unity.

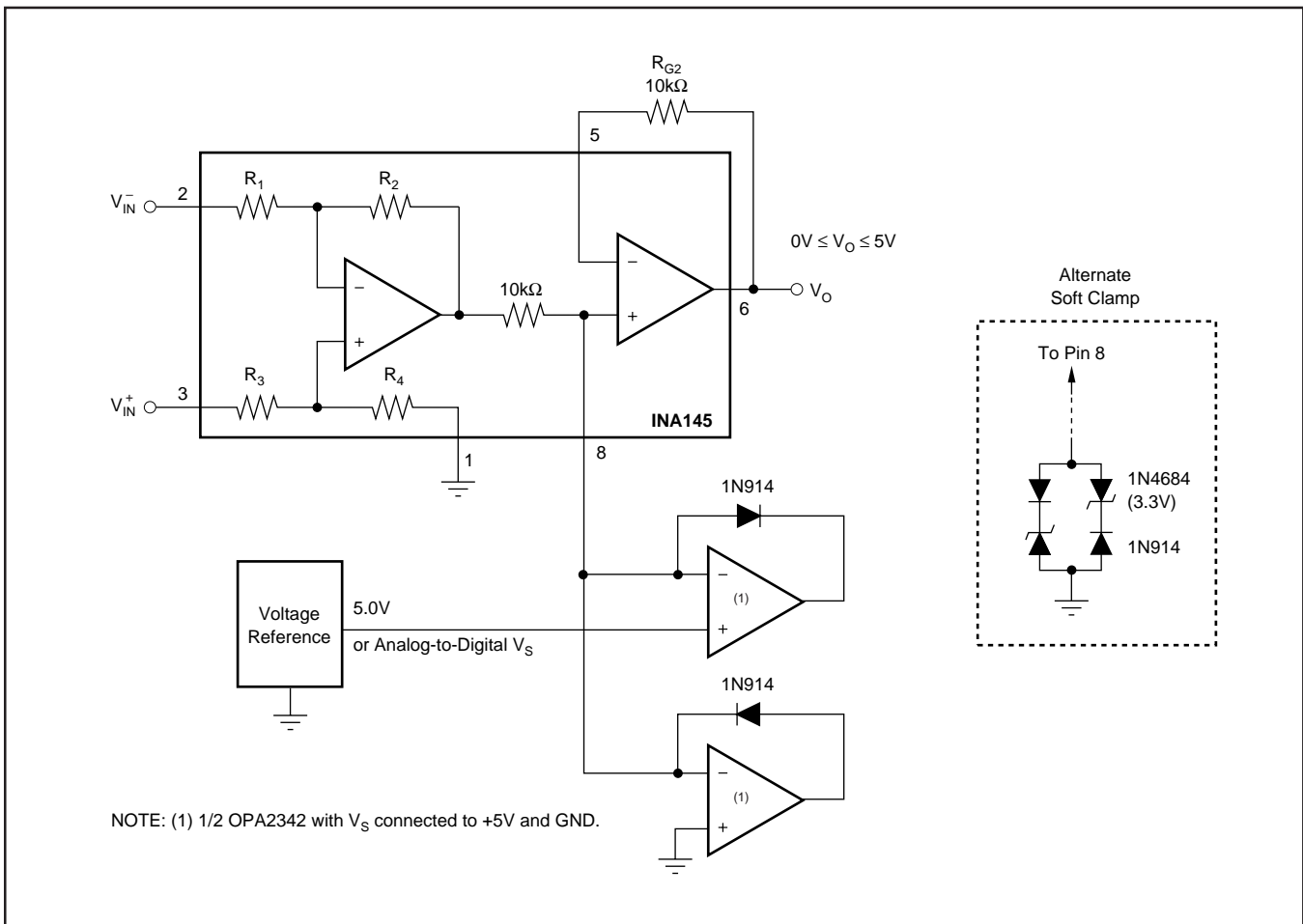

FIGURE 6. Clamp Circuits.

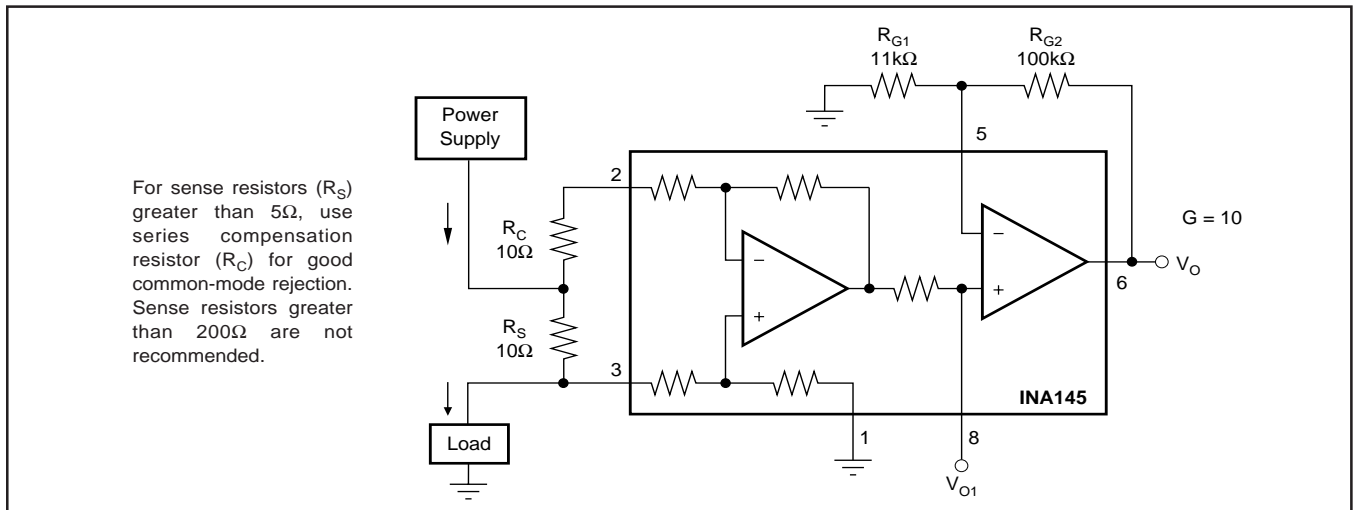

FIGURE 7. Current Monitor,  $G = 1$ .

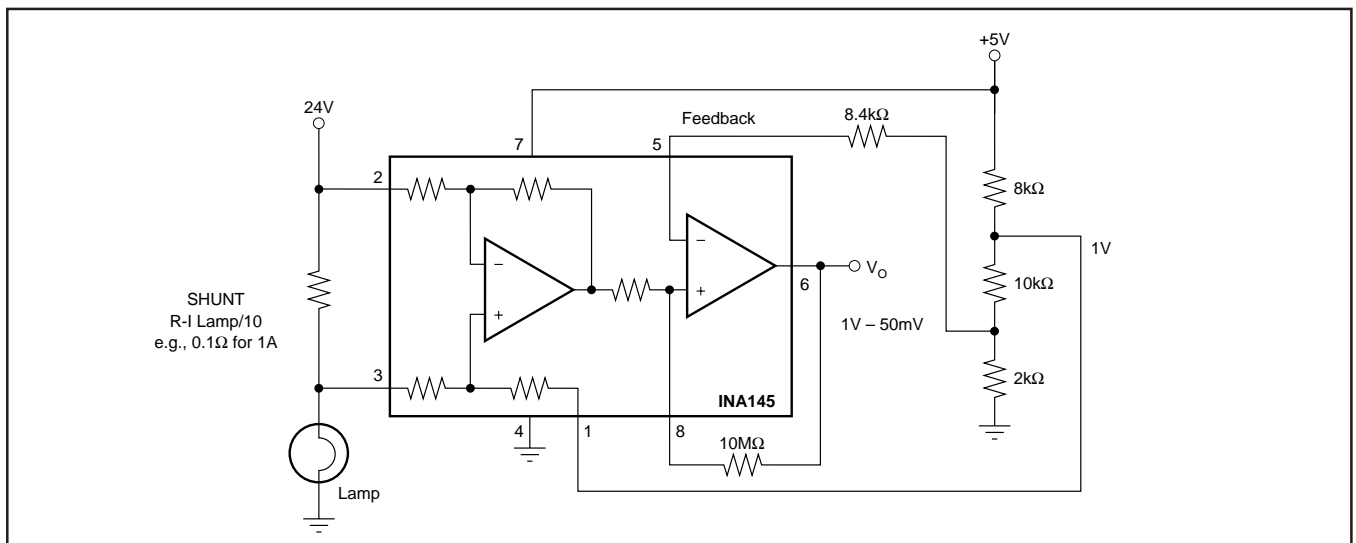

FIGURE 8. Comparator Output with Optional Hysteresis Application to Sense Lamp Burn-Out.

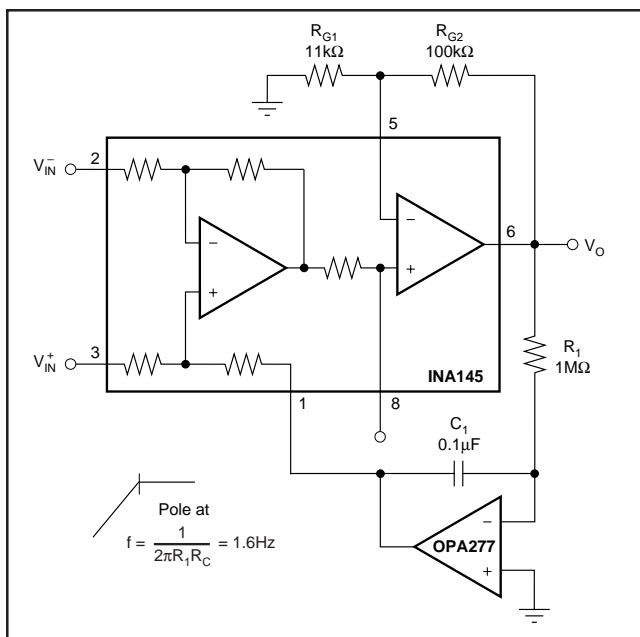

FIGURE 9. AC Coupling (DC Restoration).

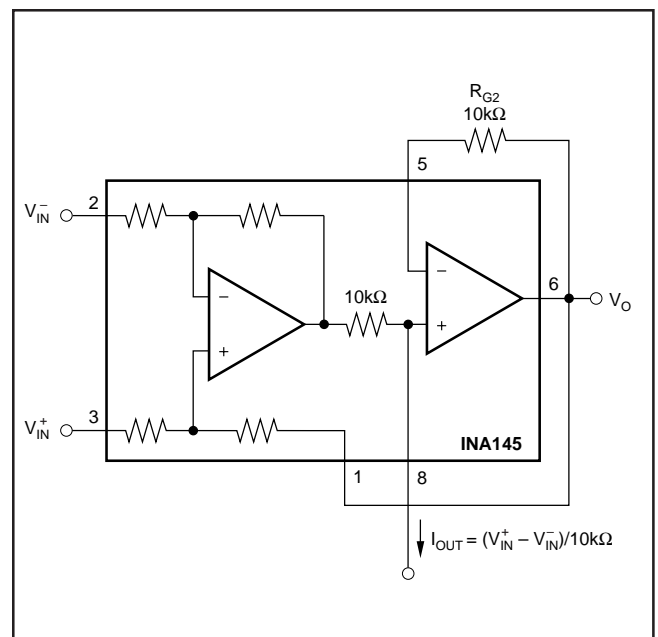

FIGURE 10. Precision Current Source.

**PACKAGING INFORMATION**

Orderable Device	Status <sup>(1)</sup>	Package Type	Package Drawing	Pins	Package Qty	Eco Plan <sup>(2)</sup>	Lead/Ball Finish	MSL Peak Temp <sup>(3)</sup>
INA145UA	ACTIVE	SOIC	D	8	75	Green (RoHS & no Sb/Br)	CU NIPDAU	Level-3-260C-168 HR
INA145UA/2K5	ACTIVE	SOIC	D	8	2500	Green (RoHS & no Sb/Br)	CU NIPDAU	Level-3-260C-168 HR
INA145UA/2K5E4	ACTIVE	SOIC	D	8	2500	Green (RoHS & no Sb/Br)	CU NIPDAU	Level-3-260C-168 HR
INA145UAE4	ACTIVE	SOIC	D	8	75	Green (RoHS & no Sb/Br)	CU NIPDAU	Level-3-260C-168 HR

<sup>(1)</sup> The marketing status values are defined as follows:

**ACTIVE:** Product device recommended for new designs.

**LIFEBUY:** TI has announced that the device will be discontinued, and a lifetime-buy period is in effect.

**NRND:** Not recommended for new designs. Device is in production to support existing customers, but TI does not recommend using this part in a new design.

**PREVIEW:** Device has been announced but is not in production. Samples may or may not be available.

**OBSOLETE:** TI has discontinued the production of the device.

<sup>(2)</sup> Eco Plan - The planned eco-friendly classification: Pb-Free (RoHS), Pb-Free (RoHS Exempt), or Green (RoHS & no Sb/Br) - please check <http://www.ti.com/productcontent> for the latest availability information and additional product content details.

**TBD:** The Pb-Free/Green conversion plan has not been defined.

**Pb-Free (RoHS):** TI's terms "Lead-Free" or "Pb-Free" mean semiconductor products that are compatible with the current RoHS requirements for all 6 substances, including the requirement that lead not exceed 0.1% by weight in homogeneous materials. Where designed to be soldered at high temperatures, TI Pb-Free products are suitable for use in specified lead-free processes.

**Pb-Free (RoHS Exempt):** This component has a RoHS exemption for either 1) lead-based flip-chip solder bumps used between the die and package, or 2) lead-based die adhesive used between the die and leadframe. The component is otherwise considered Pb-Free (RoHS compatible) as defined above.

**Green (RoHS & no Sb/Br):** TI defines "Green" to mean Pb-Free (RoHS compatible), and free of Bromine (Br) and Antimony (Sb) based flame retardants (Br or Sb do not exceed 0.1% by weight in homogeneous material)

<sup>(3)</sup> MSL, Peak Temp. -- The Moisture Sensitivity Level rating according to the JEDEC industry standard classifications, and peak solder temperature.

**Important Information and Disclaimer:**The information provided on this page represents TI's knowledge and belief as of the date that it is provided. TI bases its knowledge and belief on information provided by third parties, and makes no representation or warranty as to the accuracy of such information. Efforts are underway to better integrate information from third parties. TI has taken and continues to take reasonable steps to provide representative and accurate information but may not have conducted destructive testing or chemical analysis on incoming materials and chemicals. TI and TI suppliers consider certain information to be proprietary, and thus CAS numbers and other limited information may not be available for release.

In no event shall TI's liability arising out of such information exceed the total purchase price of the TI part(s) at issue in this document sold by TI to Customer on an annual basis.

**TAPE AND REEL INFORMATION**



**QUADRANT ASSIGNMENTS FOR PIN 1 ORIENTATION IN TAPE**



\*All dimensions are nominal

Device	Package Type	Package Drawing	Pins	SPQ	Reel Diameter (mm)	Reel Width W1 (mm)	A0 (mm)	B0 (mm)	K0 (mm)	P1 (mm)	W (mm)	Pin1 Quadrant
INA145UA/2K5	SOIC	D	8	2500	330.0	12.4	6.4	5.2	2.1	8.0	12.0	Q1

**TAPE AND REEL BOX DIMENSIONS**



\*All dimensions are nominal

Device	Package Type	Package Drawing	Pins	SPQ	Length (mm)	Width (mm)	Height (mm)
INA145UA/2K5	SOIC	D	8	2500	346.0	346.0	29.0

## IMPORTANT NOTICE

Texas Instruments Incorporated and its subsidiaries (TI) reserve the right to make corrections, modifications, enhancements, improvements, and other changes to its products and services at any time and to discontinue any product or service without notice. Customers should obtain the latest relevant information before placing orders and should verify that such information is current and complete. All products are sold subject to TI's terms and conditions of sale supplied at the time of order acknowledgment.

TI warrants performance of its hardware products to the specifications applicable at the time of sale in accordance with TI's standard warranty. Testing and other quality control techniques are used to the extent TI deems necessary to support this warranty. Except where mandated by government requirements, testing of all parameters of each product is not necessarily performed.

TI assumes no liability for applications assistance or customer product design. Customers are responsible for their products and applications using TI components. To minimize the risks associated with customer products and applications, customers should provide adequate design and operating safeguards.

TI does not warrant or represent that any license, either express or implied, is granted under any TI patent right, copyright, mask work right, or other TI intellectual property right relating to any combination, machine, or process in which TI products or services are used. Information published by TI regarding third-party products or services does not constitute a license from TI to use such products or services or a warranty or endorsement thereof. Use of such information may require a license from a third party under the patents or other intellectual property of the third party, or a license from TI under the patents or other intellectual property of TI.

Reproduction of TI information in TI data books or data sheets is permissible only if reproduction is without alteration and is accompanied by all associated warranties, conditions, limitations, and notices. Reproduction of this information with alteration is an unfair and deceptive business practice. TI is not responsible or liable for such altered documentation. Information of third parties may be subject to additional restrictions.

Resale of TI products or services with statements different from or beyond the parameters stated by TI for that product or service voids all express and any implied warranties for the associated TI product or service and is an unfair and deceptive business practice. TI is not responsible or liable for any such statements.

TI products are not authorized for use in safety-critical applications (such as life support) where a failure of the TI product would reasonably be expected to cause severe personal injury or death, unless officers of the parties have executed an agreement specifically governing such use. Buyers represent that they have all necessary expertise in the safety and regulatory ramifications of their applications, and acknowledge and agree that they are solely responsible for all legal, regulatory and safety-related requirements concerning their products and any use of TI products in such safety-critical applications, notwithstanding any applications-related information or support that may be provided by TI. Further, Buyers must fully indemnify TI and its representatives against any damages arising out of the use of TI products in such safety-critical applications.

TI products are neither designed nor intended for use in military/aerospace applications or environments unless the TI products are specifically designated by TI as military-grade or "enhanced plastic." Only products designated by TI as military-grade meet military specifications. Buyers acknowledge and agree that any such use of TI products which TI has not designated as military-grade is solely at the Buyer's risk, and that they are solely responsible for compliance with all legal and regulatory requirements in connection with such use.

TI products are neither designed nor intended for use in automotive applications or environments unless the specific TI products are designated by TI as compliant with ISO/TS 16949 requirements. Buyers acknowledge and agree that, if they use any non-designated products in automotive applications, TI will not be responsible for any failure to meet such requirements.

Following are URLs where you can obtain information on other Texas Instruments products and application solutions:

### Products

Amplifiers	<a href="http://amplifier.ti.com">amplifier.ti.com</a>
Data Converters	<a href="http://dataconverter.ti.com">dataconverter.ti.com</a>
DLP® Products	<a href="http://www.dlp.com">www.dlp.com</a>
DSP	<a href="http://dsp.ti.com">dsp.ti.com</a>
Clocks and Timers	<a href="http://www.ti.com/clocks">www.ti.com/clocks</a>
Interface	<a href="http://interface.ti.com">interface.ti.com</a>
Logic	<a href="http://logic.ti.com">logic.ti.com</a>
Power Mgmt	<a href="http://power.ti.com">power.ti.com</a>
Microcontrollers	<a href="http://microcontroller.ti.com">microcontroller.ti.com</a>
RFID	<a href="http://www.ti-rfid.com">www.ti-rfid.com</a>
RF/IF and ZigBee® Solutions	<a href="http://www.ti.com/lprf">www.ti.com/lprf</a>

### Applications

Audio	<a href="http://www.ti.com/audio">www.ti.com/audio</a>
Automotive	<a href="http://www.ti.com/automotive">www.ti.com/automotive</a>
Broadband	<a href="http://www.ti.com/broadband">www.ti.com/broadband</a>
Digital Control	<a href="http://www.ti.com/digitalcontrol">www.ti.com/digitalcontrol</a>
Medical	<a href="http://www.ti.com/medical">www.ti.com/medical</a>
Military	<a href="http://www.ti.com/military">www.ti.com/military</a>
Optical Networking	<a href="http://www.ti.com/opticalnetwork">www.ti.com/opticalnetwork</a>
Security	<a href="http://www.ti.com/security">www.ti.com/security</a>
Telephony	<a href="http://www.ti.com/telephony">www.ti.com/telephony</a>
Video & Imaging	<a href="http://www.ti.com/video">www.ti.com/video</a>
Wireless	<a href="http://www.ti.com/wireless">www.ti.com/wireless</a>

Mailing Address: Texas Instruments, Post Office Box 655303, Dallas, Texas 75265  
Copyright © 2009, Texas Instruments Incorporated