

LM26LV

1.6 V, LLP-6 Factory Preset Temperature Switch and Temperature Sensor

General Description

The LM26LV is a low-voltage, precision, dual-output, low-power temperature switch and temperature sensor. The temperature trip point (T_{TRIP}) can be preset at the factory to any temperature in the range of 0°C to 150°C in 1°C increments. Built-in temperature hysteresis (T_{HYST}) keeps the output stable in an environment of temperature instability.

In normal operation the LM26LV temperature switch outputs assert when the die temperature exceeds T_{TRIP} . The temperature switch outputs will reset when the temperature falls below a temperature equal to $(T_{TRIP} - T_{HYST})$. The $\overline{OVERTEMP}$ digital output, is active-high with a push-pull structure, while the $\overline{OVERTEMP}$ digital output, is active-low with an open-drain structure.

The analog output, V_{TEMP} , delivers an analog output voltage with Negative Temperature Coefficient — NTC.

Driving the TRIP TEST input high: (1) causes the digital outputs to be asserted for in-situ verification and, (2) causes the threshold voltage to appear at the V_{TEMP} output pin, which could be used to verify the temperature trip point.

The LM26LV's low minimum supply voltage makes it ideal for 1.8 Volt system designs. Its wide operating range, low supply current, and excellent accuracy provide a temperature switch solution for a wide range of commercial and industrial applications.

Applications

- Cell phones
- Wireless Transceivers
- Digital Cameras
- Personal Digital Assistants (PDA's)
- Battery Management
- Automotive

- Disk Drives
- Games
- Appliances

Features

- Low 1.6V operation
- Low quiescent current
- Latching function: device can latch the Over Temperature condition
- Push-pull and open-drain temperature switch outputs
- Wide trip point range of 0°C to 150°C
- Very linear analog V_{TEMP} temperature sensor output
- V_{TEMP} output short-circuit protected
- Accurate over -50°C to 150°C temperature range
- 2.2 mm by 2.5 mm (typ) LLP-6 package
- Excellent power supply noise rejection

Key Specifications

| | |
|------------------------------------|--------------------------|
| ■ Supply Voltage | 1.6V to 5.5V |
| ■ Supply Current | 8 μ A (typ) |
| ■ Accuracy, Trip Point Temperature | 0°C to 150°C \pm 2.2°C |
| ■ Accuracy, V_{TEMP} | 0°C to 150°C \pm 2.3°C |
| | 0°C to 120°C \pm 2.2°C |
| | -50°C to 0°C \pm 1.7°C |
| ■ V_{TEMP} Output Drive | \pm 100 μ A |
| ■ Operating Temperature | -50°C to 150°C |
| ■ Hysteresis Temperature | 4.5°C to 5.5°C |

Connection Diagram

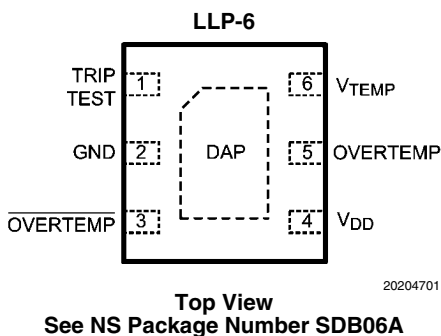

Typical Transfer Characteristic

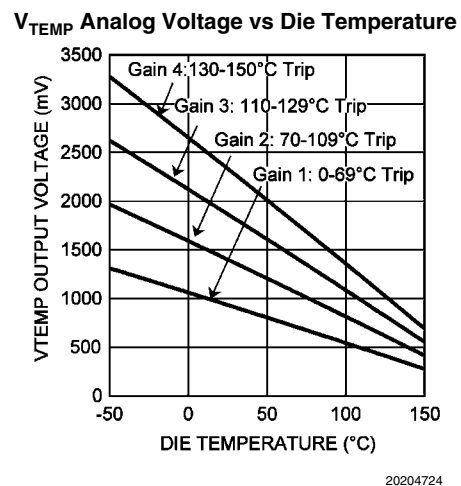

Block Diagram

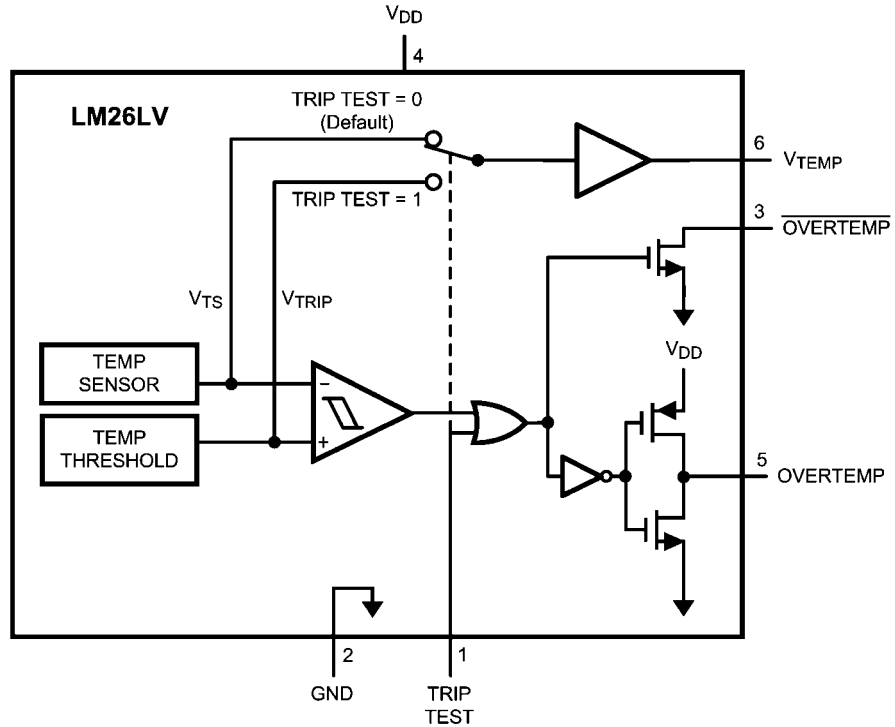

20204703

Pin Descriptions

| Pin No. | Name | Type | Equivalent Circuit | Description |
|---------|------------------------------|----------------|--------------------|---|
| 1 | TRIP TEST | Digital Input | | TRIP TEST pin. Active High input. If TRIP TEST = 0 (Default) then: $V_{TEMP} = V_{TS}$, Temperature Sensor Output Voltage If TRIP TEST = 1 then: $\overline{\text{OVERTEMP}}$ and $\overline{\text{OVERTEMP}}$ outputs are asserted and $V_{TEMP} = V_{TRIP}$, Temperature Trip Voltage. This pin may be left open if not used. |
| 5 | OVERTEMP | Digital Output | | Over Temperature Switch output Active High, Push-Pull Asserted when the measured temperature exceeds the Trip Point Temperature or if TRIP TEST = 1 This pin may be left open if not used. |
| 3 | $\overline{\text{OVERTEMP}}$ | Digital Output | | Over Temperature Switch output Active Low, Open-drain (See Section 2.1 regarding required pull-up resistor.) Asserted when the measured temperature exceeds the Trip Point Temperature or if TRIP TEST = 1 This pin may be left open if not used. |

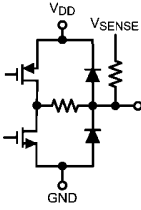
| Pin No. | Name | Type | Equivalent Circuit | Description |
|---------|----------------|---------------|---|---|
| 6 | V_{TEMP} | Analog Output |  | V_{TEMP} Analog Voltage Output If TRIP TEST = 0 then $V_{TEMP} = V_{TS}$, Temperature Sensor Output Voltage If TRIP TEST = 1 then $V_{TEMP} = V_{TRIP}$, Temperature Trip Voltage This pin may be left open if not used. |
| 4 | V_{DD} | Power | | Positive Supply Voltage |
| 2 | GND | Ground | | Power Supply Ground |
| DAP | Die Attach Pad | | | The best thermal conductivity between the device and the PCB is achieved by soldering the DAP of the package to the thermal pad on the PCB. The thermal pad can be a floating node. However, for improved noise immunity the thermal pad should be connected to the circuit GND node, preferably directly to pin 2 (GND) of the device. |

Typical Application

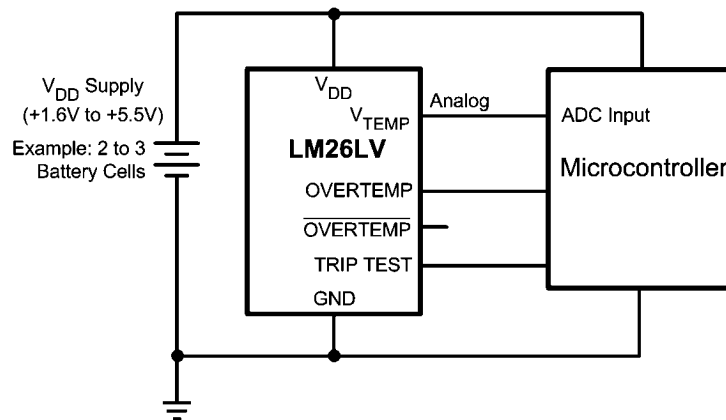

20204702

Ordering Information

| Order Number | Temperature Trip Point, °C | NS Package Number | Top Mark | Transport Media |
|-----------------|----------------------------|-------------------|----------|-----------------------------|
| LM26LVCISD-150 | 150°C | SDB06A | 150 | 1000 Units on Tape and Reel |
| LM26LVCISDX-150 | 150°C | SDB06A | 150 | 4500 Units on Tape and Reel |
| LM26LVCISD-145 | 145°C | SDB06A | 145 | 1000 Units on Tape and Reel |
| LM26LVCISDX-145 | 145°C | SDB06A | 145 | 4500 Units on Tape and Reel |
| LM26LVCISD-140 | 140°C | SDB06A | 140 | 1000 Units on Tape and Reel |
| LM26LVCISDX-140 | 140°C | SDB06A | 140 | 4500 Units on Tape and Reel |
| LM26LVCISD-135 | 135°C | SDB06A | 135 | 1000 Units on Tape and Reel |
| LM26LVCISDX-135 | 135°C | SDB06A | 135 | 4500 Units on Tape and Reel |
| LM26LVCISD-130 | 130°C | SDB06A | 130 | 1000 Units on Tape and Reel |
| LM26LVCISDX-130 | 130°C | SDB06A | 130 | 4500 Units on Tape and Reel |
| LM26LVCISD-125 | 125°C | SDB06A | 125 | 1000 Units on Tape and Reel |
| LM26LVCISDX-125 | 125°C | SDB06A | 125 | 4500 Units on Tape and Reel |
| LM26LVCISD-120 | 120°C | SDB06A | 120 | 1000 Units on Tape and Reel |
| LM26LVCISDX-120 | 120°C | SDB06A | 120 | 4500 Units on Tape and Reel |
| LM26LVCISD-115 | 115°C | SDB06A | 115 | 1000 Units on Tape and Reel |
| LM26LVCISDX-115 | 115°C | SDB06A | 115 | 4500 Units on Tape and Reel |
| LM26LVCISD-110 | 110°C | SDB06A | 110 | 1000 Units on Tape and Reel |
| LM26LVCISDX-110 | 110°C | SDB06A | 110 | 4500 Units on Tape and Reel |
| LM26LVCISD-105 | 105°C | SDB06A | 105 | 1000 Units on Tape and Reel |
| LM26LVCISDX-105 | 105°C | SDB06A | 105 | 4500 Units on Tape and Reel |
| LM26LVCISD-100 | 100°C | SDB06A | 100 | 1000 Units on Tape and Reel |
| LM26LVCISDX-100 | 100°C | SDB06A | 100 | 4500 Units on Tape and Reel |
| LM26LVCISD-095 | 95°C | SDB06A | 095 | 1000 Units on Tape and Reel |
| LM26LVCISDX-095 | 95°C | SDB06A | 095 | 4500 Units on Tape and Reel |
| LM26LVCISD-090 | 90°C | SDB06A | 090 | 1000 Units on Tape and Reel |
| LM26LVCISDX-090 | 90°C | SDB06A | 090 | 4500 Units on Tape and Reel |
| LM26LVCISD-085 | 85°C | SDB06A | 085 | 1000 Units on Tape and Reel |
| LM26LVCISDX-085 | 85°C | SDB06A | 085 | 4500 Units on Tape and Reel |
| LM26LVCISD-080 | 80°C | SDB06A | 080 | 1000 Units on Tape and Reel |
| LM26LVCISDX-080 | 80°C | SDB06A | 080 | 4500 Units on Tape and Reel |
| LM26LVCISD-075 | 75°C | SDB06A | 075 | 1000 Units on Tape and Reel |
| LM26LVCISDX-075 | 75°C | SDB06A | 075 | 4500 Units on Tape and Reel |
| LM26LVCISD-070 | 70°C | SDB06A | 070 | 1000 Units on Tape and Reel |
| LM26LVCISDX-070 | 70°C | SDB06A | 070 | 4500 Units on Tape and Reel |
| LM26LVCISD-065 | 65°C | SDB06A | 065 | 1000 Units on Tape and Reel |
| LM26LVCISDX-065 | 65°C | SDB06A | 065 | 4500 Units on Tape and Reel |
| LM26LVCISD-060 | 60°C | SDB06A | 060 | 1000 Units on Tape and Reel |
| LM26LVCISDX-060 | 60°C | SDB06A | 060 | 4500 Units on Tape and Reel |
| LM26LVCISD-050 | 50°C | SDB06A | 050 | 1000 Units on Tape and Reel |
| LM26LVCISDX-050 | 50°C | SDB06A | 050 | 4500 Units on Tape and Reel |

Absolute Maximum Ratings *(Note 1)*

| | |
|--|--|
| Supply Voltage | -0.3V to +6.0V |
| Voltage at $\overline{\text{OVERTEMP}}$ pin | -0.3V to +6.0V |
| Voltage at $\overline{\text{OVERTEMP}}$ and V_{TEMP} pins | -0.3V to ($V_{\text{DD}} + 0.5\text{V}$) |
| TRIP TEST Input Voltage | -0.3V to ($V_{\text{DD}} + 0.5\text{V}$) |
| Output Current, any output pin | ± 7 mA |
| Input Current at any pin <i>(Note 2)</i> | 5 mA |
| Storage Temperature | -65°C to +150°C |
| Maximum Junction Temperature $T_{\text{J(MAX)}}$ | +155°C |
| ESD Susceptibility <i>(Note 3)</i> : | |
| Human Body Model | 4500V |
| Machine Model | 300V |
| Charged Device Model | 1000V |

For soldering specifications: see product folder at www.national.com and www.national.com/ms/MS/MS-SOLDERING.pdf

Accuracy Characteristics

Trip Point Accuracy

| Parameter | Conditions | | Limits <i>(Note 6)</i> | Units (Limit) |
|-------------------------------------|------------|-------------------------|---------------------------|-------------------------|
| Trip Point Accuracy <i>(Note 7)</i> | 0 – 150°C | $V_{\text{DD}} = 5.0$ V | ± 2.2 | °C (max) |

Operating Ratings *(Note 1)*

| | |
|---|--|
| Specified Temperature Range: | $T_{\text{MIN}} \leq T_{\text{A}} \leq T_{\text{MAX}}$ |
| LM26LV | -50°C $\leq T_{\text{A}} \leq$ +150°C |
| Supply Voltage Range (V_{DD}) | +1.6 V to +5.5 V |
| Thermal Resistance (θ_{JA}) <i>(Note 4)</i> | |
| LLP-6 (Package SDB06A) | 152 °C/W |

V_{TEMP} Analog Temperature Sensor Output Accuracy

There are four gains corresponding to each of the four Temperature Trip Point Ranges. Gain 1 is the sensor gain used for Temperature Trip Point 0 - 69°C. Likewise Gain 2 is for Trip Points 70 - 109 °C; Gain 3 for 110 - 129 °C; and Gain 4 for 130 - 150 °C. These limits do not include DC load regulation. These stated accuracy limits are with reference to the values in the LM26LV Conversion Table.

| Parameter | Conditions | | Limits (Note 6) | Units (Limit) | |
|--|--|--------------------------------|--------------------------------|------------------|----------|
| V _{TEMP} Temperature Accuracy (Note 7) | Gain 1: for Trip Point Range 0 - 69°C | T _A = 20°C to 40°C | V _{DD} = 1.6 to 5.5 V | ±1.8 | °C (max) |
| | | T _A = 0°C to 70°C | V _{DD} = 1.6 to 5.5 V | ±2.0 | |
| | | T _A = 0°C to 90°C | V _{DD} = 1.6 to 5.5 V | ±2.1 | |
| | | T _A = 0°C to 120°C | V _{DD} = 1.6 to 5.5 V | ±2.2 | |
| | | T _A = 0°C to 150°C | V _{DD} = 1.6 to 5.5 V | ±2.3 | |
| | | T _A = -50°C to 0°C | V _{DD} = 1.7 to 5.5 V | ±1.7 | |
| | Gain 2: for Trip Point Range 70 - 109°C | T _A = 20°C to 40°C | V _{DD} = 1.8 to 5.5 V | ±1.8 | °C (max) |
| | | T _A = 0°C to 70°C | V _{DD} = 1.9 to 5.5 V | ±2.0 | |
| | | T _A = 0°C to 90°C | V _{DD} = 1.9 to 5.5 V | ±2.1 | |
| | | T _A = 0°C to 120°C | V _{DD} = 1.9 to 5.5 V | ±2.2 | |
| | | T _A = 0°C to 150°C | V _{DD} = 1.9 to 5.5 V | ±2.3 | |
| | | T _A = -50°C to 0°C | V _{DD} = 2.3 to 5.5 V | ±1.7 | |
| | Gain 3: for Trip Point Range 110 - 129°C | T _A = 20°C to 40°C | V _{DD} = 2.3 to 5.5 V | ±1.8 | °C (max) |
| | | T _A = 0°C to 70°C | V _{DD} = 2.5 to 5.5 V | ±2.0 | |
| | | T _A = 0°C to 90°C | V _{DD} = 2.5 to 5.5 V | ±2.1 | |
| | | T _A = 0°C to 120°C | V _{DD} = 2.5 to 5.5 V | ±2.2 | |
| | | T _A = 0°C to 150°C | V _{DD} = 2.5 to 5.5 V | ±2.3 | |
| | | T _A = -50°C to 0°C | V _{DD} = 3.0 to 5.5 V | ±1.7 | |
| | Gain 4: for Trip Point Range 130 - 150°C | T _A = 20°C to 40°C | V _{DD} = 2.7 to 5.5 V | ±1.8 | °C (max) |
| | | T _A = 0°C to 70°C | V _{DD} = 3.0 to 5.5 V | ±2.0 | |
| T _A = 0°C to 90°C | | V _{DD} = 3.0 to 5.5 V | ±2.1 | | |
| T _A = 0°C to 120°C | | V _{DD} = 3.0 to 5.5 V | ±2.2 | | |
| T _A = 0°C to 150°C | | V _{DD} = 3.0 to 5.5 V | ±2.3 | | |
| T _A = -50°C to 0°C | | V _{DD} = 3.6 to 5.5 V | ±1.7 | | |

Electrical Characteristics

Unless otherwise noted, these specifications apply for $V_{DD} = +1.6V$ to $+5.5V$. **Boldface limits apply for $T_A = T_J = T_{MIN}$ to T_{MAX}** ; all other limits $T_A = T_J = 25^\circ C$.

| Symbol | Parameter | Conditions | Typical (Note 5) | Limits (Note 6) | Units (Limit) | | |
|---|--|--|--|------------------------------|------------------------------------|---------------|-----|
| GENERAL SPECIFICATIONS | | | | | | | |
| I_S | Quiescent Power Supply Current | | 8 | 16 | μA (max) | | |
| | Hysteresis | | 5 | 5.5 | $^\circ C$ (max) | | |
| | | | | 4.5 | $^\circ C$ (Min) | | |
| OVERTEMP DIGITAL OUTPUT | | ACTIVE HIGH, PUSH-PULL | | | | | |
| V_{OH} | Logic "1" Output Voltage | $V_{DD} \geq 1.6V$ | Source $\leq 340 \mu A$ | | $V_{DD} - 0.2V$ | V (min) | |
| | | $V_{DD} \geq 2.0V$ | Source $\leq 498 \mu A$ | | | | |
| | | $V_{DD} \geq 3.3V$ | Source $\leq 780 \mu A$ | | | | |
| | | $V_{DD} \geq 1.6V$ | Source $\leq 600 \mu A$ | | $V_{DD} - 0.45V$ | V (min) | |
| | | $V_{DD} \geq 2.0V$ | Source $\leq 980 \mu A$ | | | | |
| | | $V_{DD} \geq 3.3V$ | Source $\leq 1.6 mA$ | | | | |
| BOTH OVERTEMP and $\overline{OVERTEMP}$ DIGITAL OUTPUTS | | | | | | | |
| V_{OL} | Logic "0" Output Voltage | $V_{DD} \geq 1.6V$ | Sink $\leq 385 \mu A$ | | 0.2 | V (max) | |
| | | $V_{DD} \geq 2.0V$ | Sink $\leq 500 \mu A$ | | | | |
| | | $V_{DD} \geq 3.3V$ | Sink $\leq 730 \mu A$ | | | | |
| | | $V_{DD} \geq 1.6V$ | Sink $\leq 690 \mu A$ | | 0.45 | | |
| | | $V_{DD} \geq 2.0V$ | Sink $\leq 1.05 mA$ | | | | |
| | | $V_{DD} \geq 3.3V$ | Sink $\leq 1.62 mA$ | | | | |
| OVERTEMP DIGITAL OUTPUT | | ACTIVE LOW, OPEN DRAIN | | | | | |
| I_{OH} | Logic "1" Output Leakage Current (Note 10) | $T_A = 30^\circ C$ | 0.001 | 1 | μA (max) | | |
| | | $T_A = 150^\circ C$ | 0.025 | | | | |
| V_{TEMP} ANALOG TEMPERATURE SENSOR OUTPUT | | | | | | | |
| | V_{TEMP} Sensor Gain | Gain 1: If Trip Point = 0 - 69 $^\circ C$ | | -5.1 | | $mV/^\circ C$ | |
| | | Gain 2: If Trip Point = 70 - 109 $^\circ C$ | | -7.7 | | $mV/^\circ C$ | |
| | | Gain 3: If Trip Point = 110 - 129 $^\circ C$ | | -10.3 | | $mV/^\circ C$ | |
| | | Gain 4: If Trip Point = 130 - 150 $^\circ C$ | | -12.8 | | $mV/^\circ C$ | |
| | V_{TEMP} Load Regulation (Note 9) | $1.6V \leq V_{DD} < 1.8V$ | Source $\leq 90 \mu A$ ($V_{DD} - V_{TEMP} \geq 200 mV$) | -0.1 | -1 | mV (max) | |
| | | | Sink $\leq 100 \mu A$ $V_{TEMP} \geq 260 mV$ | 0.1 | 1 | mV (max) | |
| | | $V_{DD} \geq 1.8V$ | Source $\leq 120 \mu A$ ($V_{DD} - V_{TEMP} \geq 200 mV$) | -0.1 | -1 | mV (max) | |
| | | | Sink $\leq 200 \mu A$ $V_{TEMP} \geq 260 mV$ | 0.1 | 1 | mV (max) | |
| | | | | Source or Sink = 100 μA | 1 | | Ohm |
| | | | V_{DD} Supply- to- V_{TEMP} DC Line Regulation (Note 11) | $V_{DD} = +1.6V$ to $+5.5V$ | | 0.29 | |
| 74 | | | | | | $\mu V/V$ | |
| -82 | | | | | | dB | |
| C_L | V_{TEMP} Output Load Capacitance | Without series resistor. See Section 4.2 | 1100 | | pF (max) | | |

Electrical Characteristics

Unless otherwise noted, these specifications apply for $+V_{DD} = +1.6V$ to $+5.5V$. **Boldface limits apply for $T_A = T_J = T_{MIN}$ to T_{MAX}** ; all other limits $T_A = T_J = 25^\circ C$.

| Symbol | Parameter | Conditions | Typical (Note 5) | Limits (Note 6) | Units (Limit) |
|--------------------------------|---|---|---------------------|--------------------|------------------|
| TRIP TEST DIGITAL INPUT | | | | | |
| V_{IH} | Logic "1" Threshold Voltage | | | $V_{DD} - 0.5$ | V (min) |
| V_{IL} | Logic "0" Threshold Voltage | | | 0.5 | V (max) |
| I_{IH} | Logic "1" Input Current | | 1.5 | 2.5 | μA (max) |
| I_{IL} | Logic "0" Input Current (Note 10) | | 0.001 | 1 | μA (max) |
| TIMING | | | | | |
| t_{EN} | Time from Power On to Digital Output Enabled. See definition below. | | 1.1 | 2.3 | ms (max) |
| $t_{V_{TEMP}}$ | Time from Power On to Analog Temperature Valid. See definition below. | $V_{TEMP} C_L = 0 \text{ pF to } 1100 \text{ pF}$ | 1.0 | 2.9 | ms (max) |

Definitions of t_{EN} and $t_{V_{TEMP}}$

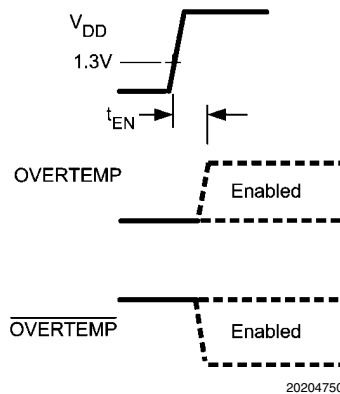

20204751

20204750

Note 1: Absolute Maximum Ratings indicate limits beyond which damage to the device may occur. Operating Ratings indicate conditions for which the device is functional, but do not guarantee specific performance limits. For guaranteed specifications and test conditions, see the Electrical Characteristics. The guaranteed specifications apply only for the test conditions listed. Some performance characteristics may degrade when the device is not operated under the listed test conditions.

Note 2: When the input voltage (V_i) at any pin exceeds power supplies ($V_i < GND$ or $V_i > V_{DD}$), the current at that pin should be limited to 5 mA.

Note 3: The Human Body Model (HBM) is a 100 pF capacitor charged to the specified voltage then discharged through a 1.5 k Ω resistor into each pin. The Machine Model (MM) is a 200 pF capacitor charged to the specified voltage then discharged directly into each pin. The Charged Device Model (CDM) is a specified circuit characterizing an ESD event that occurs when a device acquires charge through some triboelectric (frictional) or electrostatic induction processes and then abruptly touches a grounded object or surface.

Note 4: The junction to ambient temperature resistance (θ_{JA}) is specified without a heat sink in still air.

Note 5: Typicals are at $T_J = T_A = 25^\circ C$ and represent most likely parametric norm.

Note 6: Limits are guaranteed to National's AOQL (Average Outgoing Quality Level).

Note 7: Accuracy is defined as the error between the measured and reference output voltages, tabulated in the Conversion Table at the specified conditions of supply gain setting, voltage, and temperature (expressed in $^\circ C$). Accuracy limits include line regulation within the specified conditions. Accuracy limits do not include load regulation; they assume no DC load.

Note 8: Changes in output due to self heating can be computed by multiplying the internal dissipation by the temperature resistance.

Note 9: Source currents are flowing out of the LM26LV. Sink currents are flowing into the LM26LV.

Note 10: The 1 μA limit is based on a testing limitation and does not reflect the actual performance of the part. Expect to see a doubling of the current for every 15 $^\circ C$ increase in temperature. For example, the 1 nA typical current at 25 $^\circ C$ would increase to 16 nA at 85 $^\circ C$.

Note 11: Line regulation (DC) is calculated by subtracting the output voltage at the highest supply voltage from the output voltage at the lowest supply voltage. The typical DC line regulation specification does not include the output voltage shift discussed in Section 4.3.

Note 12: The curves shown represent typical performance under worst-case conditions. Performance improves with larger overhead ($V_{DD} - V_{TEMP}$), larger V_{DD} , and lower temperatures.

Note 13: The curves shown represent typical performance under worst-case conditions. Performance improves with larger V_{TEMP} , larger V_{DD} and lower temperatures.

Typical Performance Characteristics

V_{TEMP} Output Temperature Error vs. Temperature

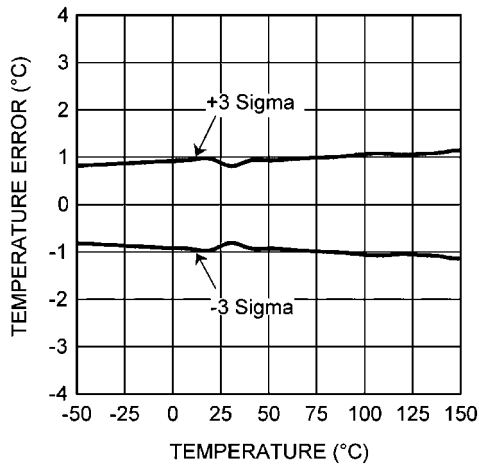

20204707

Minimum Operating Temperature vs. Supply Voltage

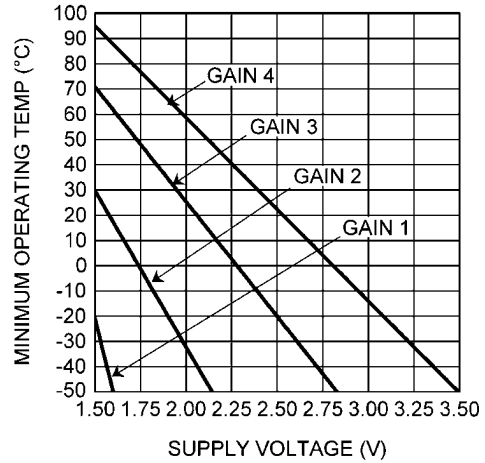

20204706

Supply Current vs. Temperature

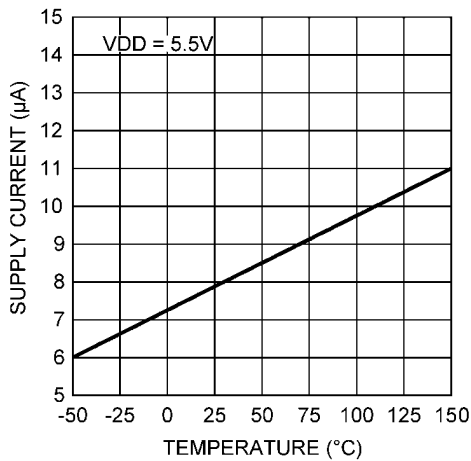

20204704

Supply Current vs. Supply Voltage

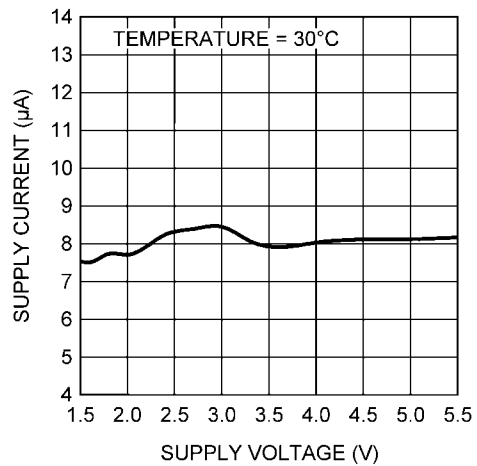

20204705

**Load Regulation, 100 mV Overhead
T = 80°C Sourcing Current (Note 12)**

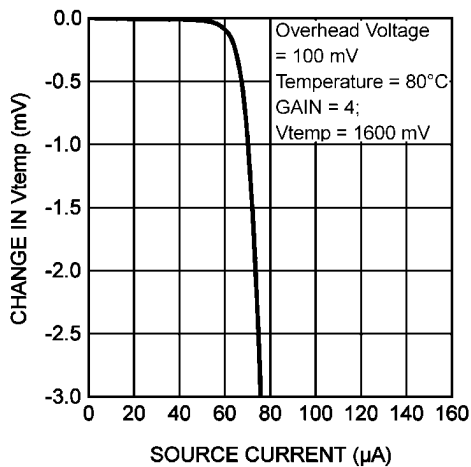

20204740

**Load Regulation, 200 mV Overhead
T = 80°C Sourcing Current (Note 12)**

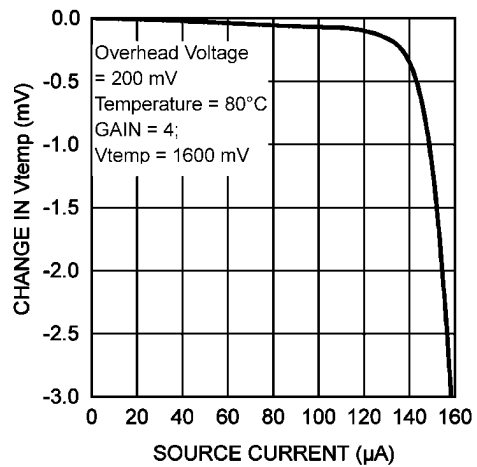

20204746

Load Regulation, 400 mV Overhead
T = 80°C Sourcing Current (Note 12)

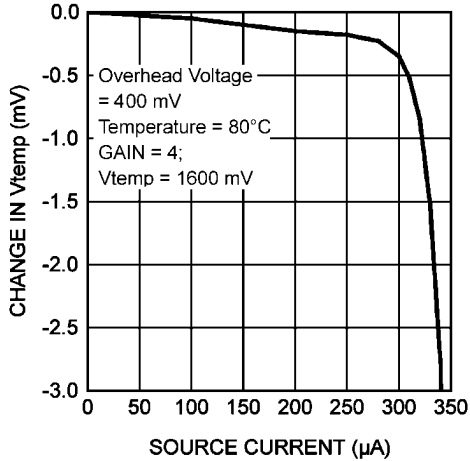

20204747

Load Regulation, 1.72V Overhead
T = 150°C, V_{DD} = 2.4V
Sourcing Current (Note 12)

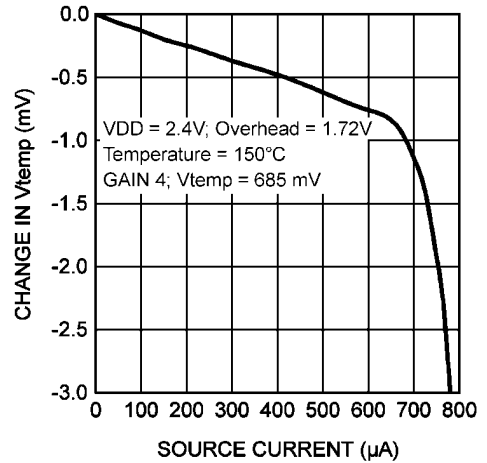

20204748

Load Regulation, V_{DD} = 1.6V
Sinking Current (Note 13)

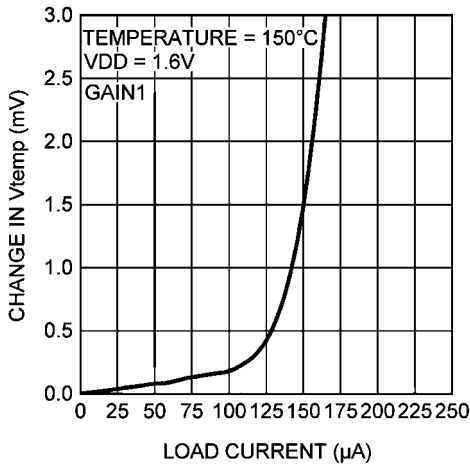

20204741

Load Regulation, V_{DD} = 1.8V
Sinking Current (Note 13)

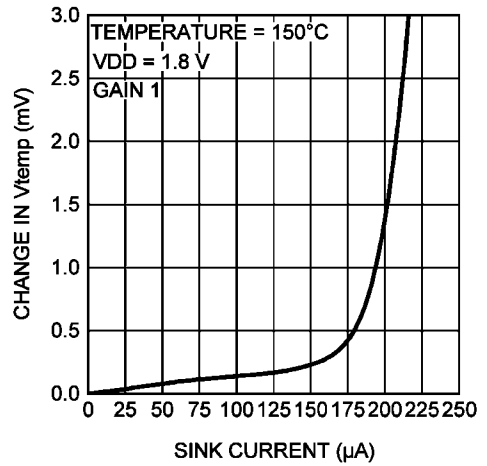

20204744

Load Regulation, V_{DD} = 2.4V
Sinking Current (Note 13)

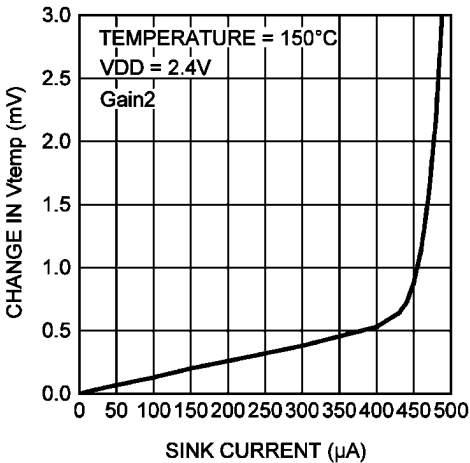

20204745

Change in V_{TEMP} vs. Overhead Voltage

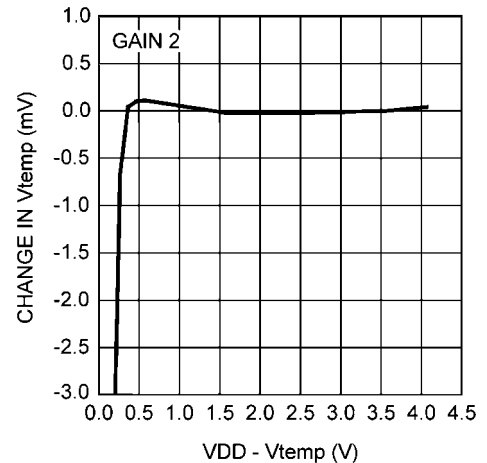

20204742

V_{TEMP} Supply-Noise Rejection vs. Frequency

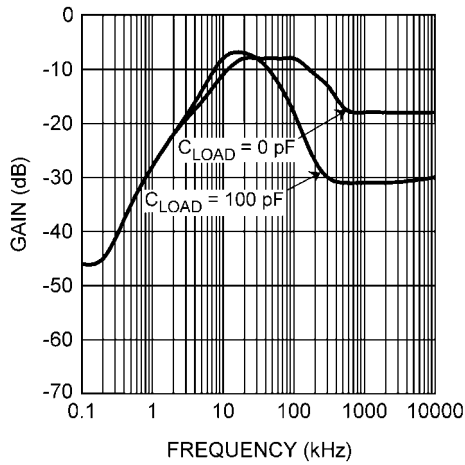

20204743

**Line Regulation
V_{TEMP} vs. Supply Voltage
Gain 1: For Trip Points
0 - 69°C**

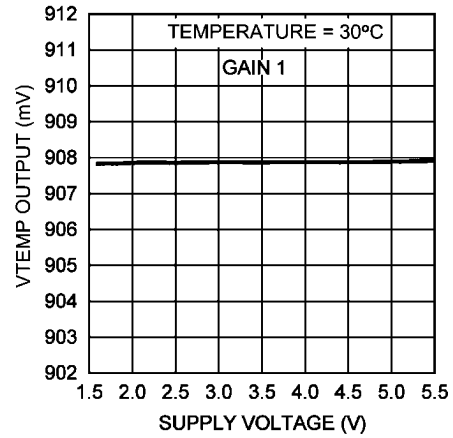

20204734

**Line Regulation
V_{TEMP} vs. Supply Voltage
Gain 2: For Trip Points
70 - 109°C**

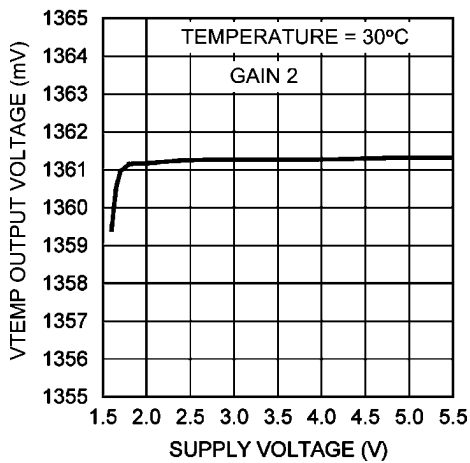

20204735

**Line Regulation
V_{TEMP} vs. Supply Voltage
Gain 3: For Trip Points
110 - 129°C**

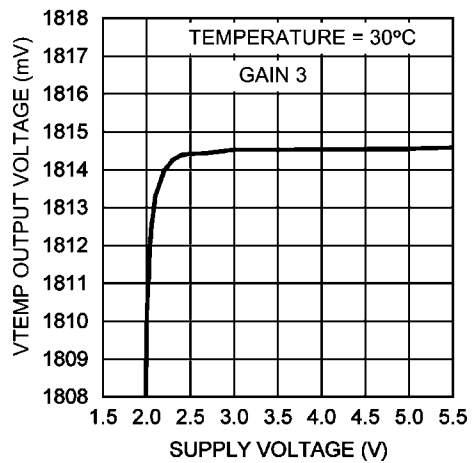

20204736

**Line Regulation
V_{TEMP} vs. Supply Voltage
Gain 4: For Trip Points
130 - 150°C**

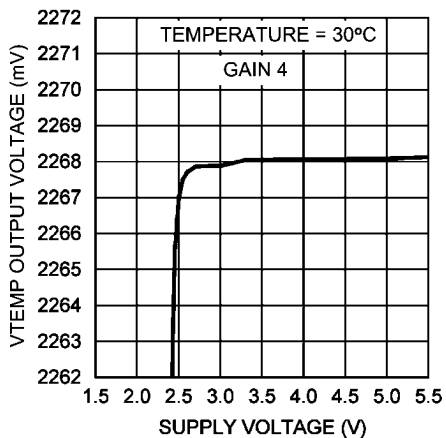

20204737

1.0 LM26LV V_{TEMP} vs Die Temperature Conversion Table

The LM26LV has one out of four possible factory-set gains, Gain 1 through Gain 4, depending on the range of the Temperature Trip Point. The V_{TEMP} temperature sensor voltage, in millivolts, at each discrete die temperature over the complete operating temperature range, and for each of the four Temperature Trip Point ranges, is shown in the Conversion Table below. This table is the reference from which the LM26LV accuracy specifications (listed in the Electrical Characteristics section) are determined. This table can be used, for example, in a host processor look-up table. See Section 1.1.1 for the parabolic equation used in the Conversion Table.

V_{TEMP} Temperature Sensor Output Voltage vs Die Temperature Conversion Table

The V_{TEMP} temperature sensor output voltage, in mV, vs Die Temperature, in °C, for each of the four gains corresponding to each of the four Temperature Trip Point Ranges. Gain 1 is the sensor gain used for Temperature Trip Point 0 - 69°C. Likewise Gain 2 is for Trip Points 70 - 109 °C; Gain 3 for 110 - 129 °C; and Gain 4 for 130 - 150 °C. $V_{DD} = 5.0V$. The values in **bold font** are for the Trip Point range.

| Die Temp., °C | V_{TEMP} , Analog Output Voltage, mV | | | |
|---------------|---|---|--|--|
| | Gain 1: for $T_{TRIP} =$ 0-69°C | Gain 2: for $T_{TRIP} =$ 70-109°C | Gain 3: for $T_{TRIP} =$ 110-129°C | Gain 4: for $T_{TRIP} =$ 130-150°C |
| -50 | 1312 | 1967 | 2623 | 3278 |
| -49 | 1307 | 1960 | 2613 | 3266 |
| -48 | 1302 | 1952 | 2603 | 3253 |
| -47 | 1297 | 1945 | 2593 | 3241 |
| -46 | 1292 | 1937 | 2583 | 3229 |
| -45 | 1287 | 1930 | 2573 | 3216 |
| -44 | 1282 | 1922 | 2563 | 3204 |
| -43 | 1277 | 1915 | 2553 | 3191 |
| -42 | 1272 | 1908 | 2543 | 3179 |
| -41 | 1267 | 1900 | 2533 | 3166 |
| -40 | 1262 | 1893 | 2523 | 3154 |
| -39 | 1257 | 1885 | 2513 | 3141 |
| -38 | 1252 | 1878 | 2503 | 3129 |
| -37 | 1247 | 1870 | 2493 | 3116 |
| -36 | 1242 | 1863 | 2483 | 3104 |
| -35 | 1237 | 1855 | 2473 | 3091 |
| -34 | 1232 | 1848 | 2463 | 3079 |
| -33 | 1227 | 1840 | 2453 | 3066 |
| -32 | 1222 | 1833 | 2443 | 3054 |
| -31 | 1217 | 1825 | 2433 | 3041 |
| -30 | 1212 | 1818 | 2423 | 3029 |
| -29 | 1207 | 1810 | 2413 | 3016 |
| -28 | 1202 | 1803 | 2403 | 3004 |
| -27 | 1197 | 1795 | 2393 | 2991 |
| -26 | 1192 | 1788 | 2383 | 2979 |
| -25 | 1187 | 1780 | 2373 | 2966 |
| -24 | 1182 | 1773 | 2363 | 2954 |
| -23 | 1177 | 1765 | 2353 | 2941 |

| Die Temp., °C | V_{TEMP} , Analog Output Voltage, mV | | | |
|---------------|---|---|--|--|
| | Gain 1: for $T_{TRIP} =$ 0-69°C | Gain 2: for $T_{TRIP} =$ 70-109°C | Gain 3: for $T_{TRIP} =$ 110-129°C | Gain 4: for $T_{TRIP} =$ 130-150°C |
| -22 | 1172 | 1757 | 2343 | 2929 |
| -21 | 1167 | 1750 | 2333 | 2916 |
| -20 | 1162 | 1742 | 2323 | 2903 |
| -19 | 1157 | 1735 | 2313 | 2891 |
| -18 | 1152 | 1727 | 2303 | 2878 |
| -17 | 1147 | 1720 | 2293 | 2866 |
| -16 | 1142 | 1712 | 2283 | 2853 |
| -15 | 1137 | 1705 | 2272 | 2841 |
| -14 | 1132 | 1697 | 2262 | 2828 |
| -13 | 1127 | 1690 | 2252 | 2815 |
| -12 | 1122 | 1682 | 2242 | 2803 |
| -11 | 1116 | 1674 | 2232 | 2790 |
| -10 | 1111 | 1667 | 2222 | 2777 |
| -9 | 1106 | 1659 | 2212 | 2765 |
| -8 | 1101 | 1652 | 2202 | 2752 |
| -7 | 1096 | 1644 | 2192 | 2740 |
| -6 | 1091 | 1637 | 2182 | 2727 |
| -5 | 1086 | 1629 | 2171 | 2714 |
| -4 | 1081 | 1621 | 2161 | 2702 |
| -3 | 1076 | 1614 | 2151 | 2689 |
| -2 | 1071 | 1606 | 2141 | 2676 |
| -1 | 1066 | 1599 | 2131 | 2664 |
| 0 | 1061 | 1591 | 2121 | 2651 |
| 1 | 1056 | 1583 | 2111 | 2638 |
| 2 | 1051 | 1576 | 2101 | 2626 |
| 3 | 1046 | 1568 | 2090 | 2613 |
| 4 | 1041 | 1561 | 2080 | 2600 |
| 5 | 1035 | 1553 | 2070 | 2587 |
| 6 | 1030 | 1545 | 2060 | 2575 |
| 7 | 1025 | 1538 | 2050 | 2562 |
| 8 | 1020 | 1530 | 2040 | 2549 |
| 9 | 1015 | 1522 | 2029 | 2537 |
| 10 | 1010 | 1515 | 2019 | 2524 |
| 11 | 1005 | 1507 | 2009 | 2511 |
| 12 | 1000 | 1499 | 1999 | 2498 |
| 13 | 995 | 1492 | 1989 | 2486 |
| 14 | 990 | 1484 | 1978 | 2473 |
| 15 | 985 | 1477 | 1968 | 2460 |
| 16 | 980 | 1469 | 1958 | 2447 |
| 17 | 974 | 1461 | 1948 | 2435 |
| 18 | 969 | 1454 | 1938 | 2422 |
| 19 | 964 | 1446 | 1927 | 2409 |
| 20 | 959 | 1438 | 1917 | 2396 |
| 21 | 954 | 1431 | 1907 | 2383 |
| 22 | 949 | 1423 | 1897 | 2371 |
| 23 | 944 | 1415 | 1886 | 2358 |

| Die Temp., °C | V _{TEMP} , Analog Output Voltage, mV | | | |
|---------------|---|--|---|---|
| | Gain 1: for T _{TRIP} = 0-69°C | Gain 2: for T _{TRIP} = 70-109°C | Gain 3: for T _{TRIP} = 110-129°C | Gain 4: for T _{TRIP} = 130-150°C |
| 24 | 939 | 1407 | 1876 | 2345 |
| 25 | 934 | 1400 | 1866 | 2332 |
| 26 | 928 | 1392 | 1856 | 2319 |
| 27 | 923 | 1384 | 1845 | 2307 |
| 28 | 918 | 1377 | 1835 | 2294 |
| 29 | 913 | 1369 | 1825 | 2281 |
| 30 | 908 | 1361 | 1815 | 2268 |
| 31 | 903 | 1354 | 1804 | 2255 |
| 32 | 898 | 1346 | 1794 | 2242 |
| 33 | 892 | 1338 | 1784 | 2230 |
| 34 | 887 | 1331 | 1774 | 2217 |
| 35 | 882 | 1323 | 1763 | 2204 |
| 36 | 877 | 1315 | 1753 | 2191 |
| 37 | 872 | 1307 | 1743 | 2178 |
| 38 | 867 | 1300 | 1732 | 2165 |
| 39 | 862 | 1292 | 1722 | 2152 |
| 40 | 856 | 1284 | 1712 | 2139 |
| 41 | 851 | 1276 | 1701 | 2127 |
| 42 | 846 | 1269 | 1691 | 2114 |
| 43 | 841 | 1261 | 1681 | 2101 |
| 44 | 836 | 1253 | 1670 | 2088 |
| 45 | 831 | 1245 | 1660 | 2075 |
| 46 | 825 | 1238 | 1650 | 2062 |
| 47 | 820 | 1230 | 1639 | 2049 |
| 48 | 815 | 1222 | 1629 | 2036 |
| 49 | 810 | 1214 | 1619 | 2023 |
| 50 | 805 | 1207 | 1608 | 2010 |
| 51 | 800 | 1199 | 1598 | 1997 |
| 52 | 794 | 1191 | 1588 | 1984 |
| 53 | 789 | 1183 | 1577 | 1971 |
| 54 | 784 | 1176 | 1567 | 1958 |
| 55 | 779 | 1168 | 1557 | 1946 |
| 56 | 774 | 1160 | 1546 | 1933 |
| 57 | 769 | 1152 | 1536 | 1920 |
| 58 | 763 | 1144 | 1525 | 1907 |
| 59 | 758 | 1137 | 1515 | 1894 |
| 60 | 753 | 1129 | 1505 | 1881 |
| 61 | 748 | 1121 | 1494 | 1868 |
| 62 | 743 | 1113 | 1484 | 1855 |
| 63 | 737 | 1105 | 1473 | 1842 |
| 64 | 732 | 1098 | 1463 | 1829 |
| 65 | 727 | 1090 | 1453 | 1816 |
| 66 | 722 | 1082 | 1442 | 1803 |
| 67 | 717 | 1074 | 1432 | 1790 |
| 68 | 711 | 1066 | 1421 | 1776 |
| 69 | 706 | 1059 | 1411 | 1763 |

| Die Temp., °C | V _{TEMP} , Analog Output Voltage, mV | | | |
|---------------|---|--|---|---|
| | Gain 1: for T _{TRIP} = 0-69°C | Gain 2: for T _{TRIP} = 70-109°C | Gain 3: for T _{TRIP} = 110-129°C | Gain 4: for T _{TRIP} = 130-150°C |
| 70 | 701 | 1051 | 1400 | 1750 |
| 71 | 696 | 1043 | 1390 | 1737 |
| 72 | 690 | 1035 | 1380 | 1724 |
| 73 | 685 | 1027 | 1369 | 1711 |
| 74 | 680 | 1019 | 1359 | 1698 |
| 75 | 675 | 1012 | 1348 | 1685 |
| 76 | 670 | 1004 | 1338 | 1672 |
| 77 | 664 | 996 | 1327 | 1659 |
| 78 | 659 | 988 | 1317 | 1646 |
| 79 | 654 | 980 | 1306 | 1633 |
| 80 | 649 | 972 | 1296 | 1620 |
| 81 | 643 | 964 | 1285 | 1607 |
| 82 | 638 | 957 | 1275 | 1593 |
| 83 | 633 | 949 | 1264 | 1580 |
| 84 | 628 | 941 | 1254 | 1567 |
| 85 | 622 | 933 | 1243 | 1554 |
| 86 | 617 | 925 | 1233 | 1541 |
| 87 | 612 | 917 | 1222 | 1528 |
| 88 | 607 | 909 | 1212 | 1515 |
| 89 | 601 | 901 | 1201 | 1501 |
| 90 | 596 | 894 | 1191 | 1488 |
| 91 | 591 | 886 | 1180 | 1475 |
| 92 | 586 | 878 | 1170 | 1462 |
| 93 | 580 | 870 | 1159 | 1449 |
| 94 | 575 | 862 | 1149 | 1436 |
| 95 | 570 | 854 | 1138 | 1422 |
| 96 | 564 | 846 | 1128 | 1409 |
| 97 | 559 | 838 | 1117 | 1396 |
| 98 | 554 | 830 | 1106 | 1383 |
| 99 | 549 | 822 | 1096 | 1370 |
| 100 | 543 | 814 | 1085 | 1357 |
| 101 | 538 | 807 | 1075 | 1343 |
| 102 | 533 | 799 | 1064 | 1330 |
| 103 | 527 | 791 | 1054 | 1317 |
| 104 | 522 | 783 | 1043 | 1304 |
| 105 | 517 | 775 | 1032 | 1290 |
| 106 | 512 | 767 | 1022 | 1277 |
| 107 | 506 | 759 | 1011 | 1264 |
| 108 | 501 | 751 | 1001 | 1251 |
| 109 | 496 | 743 | 990 | 1237 |
| 110 | 490 | 735 | 979 | 1224 |
| 111 | 485 | 727 | 969 | 1211 |
| 112 | 480 | 719 | 958 | 1198 |
| 113 | 474 | 711 | 948 | 1184 |
| 114 | 469 | 703 | 937 | 1171 |
| 115 | 464 | 695 | 926 | 1158 |

| Die Temp., °C | V _{TEMP} , Analog Output Voltage, mV | | | |
|---------------|---|---|--|--|
| | Gain 1: for T _{TRIP} = 0-69°C | Gain 2: for T _{TRIP} = 70-109°C | Gain 3: for T _{TRIP} = 110-129°C | Gain 4: for T _{TRIP} = 130-150°C |
| 116 | 459 | 687 | 916 | 1145 |
| 117 | 453 | 679 | 905 | 1131 |
| 118 | 448 | 671 | 894 | 1118 |
| 119 | 443 | 663 | 884 | 1105 |
| 120 | 437 | 655 | 873 | 1091 |
| 121 | 432 | 647 | 862 | 1078 |
| 122 | 427 | 639 | 852 | 1065 |
| 123 | 421 | 631 | 841 | 1051 |
| 124 | 416 | 623 | 831 | 1038 |
| 125 | 411 | 615 | 820 | 1025 |
| 126 | 405 | 607 | 809 | 1011 |
| 127 | 400 | 599 | 798 | 998 |
| 128 | 395 | 591 | 788 | 985 |
| 129 | 389 | 583 | 777 | 971 |
| 130 | 384 | 575 | 766 | 958 |
| 131 | 379 | 567 | 756 | 945 |
| 132 | 373 | 559 | 745 | 931 |
| 133 | 368 | 551 | 734 | 918 |
| 134 | 362 | 543 | 724 | 904 |
| 135 | 357 | 535 | 713 | 891 |
| 136 | 352 | 527 | 702 | 878 |
| 137 | 346 | 519 | 691 | 864 |
| 138 | 341 | 511 | 681 | 851 |
| 139 | 336 | 503 | 670 | 837 |
| 140 | 330 | 495 | 659 | 824 |
| 141 | 325 | 487 | 649 | 811 |
| 142 | 320 | 479 | 638 | 797 |
| 143 | 314 | 471 | 627 | 784 |
| 144 | 309 | 463 | 616 | 770 |
| 145 | 303 | 455 | 606 | 757 |
| 146 | 298 | 447 | 595 | 743 |
| 147 | 293 | 438 | 584 | 730 |
| 148 | 287 | 430 | 573 | 716 |
| 149 | 282 | 422 | 562 | 703 |
| 150 | 277 | 414 | 552 | 690 |

1.1 V_{TEMP} vs DIE TEMPERATURE APPROXIMATIONS

The LM26LV's V_{TEMP} analog temperature output is very linear. The Conversion Table above and the equation in Section 1.1.1 represent the most accurate typical performance of the V_{TEMP} voltage output vs Temperature.

1.1.1 The Second-Order Equation (Parabolic)

The data from the Conversion Table, or the equation below, when plotted, has an umbrella-shaped parabolic curve. V_{TEMP} is in mV.

$$\begin{aligned} \text{GAIN1: } V_{\text{TEMP}} &= 907.9 - 5.132 \times (T_{\text{DIE}} - 30^\circ\text{C}) - 1.08\text{e-}3 \times (T_{\text{DIE}} - 30^\circ\text{C})^2 \\ \text{GAIN2: } V_{\text{TEMP}} &= 1361.4 - 7.701 \times (T_{\text{DIE}} - 30^\circ\text{C}) - 1.60\text{e-}3 \times (T_{\text{DIE}} - 30^\circ\text{C})^2 \\ \text{GAIN3: } V_{\text{TEMP}} &= 1814.6 - 10.270 \times (T_{\text{DIE}} - 30^\circ\text{C}) - 2.12\text{e-}3 \times (T_{\text{DIE}} - 30^\circ\text{C})^2 \\ \text{GAIN4: } V_{\text{TEMP}} &= 2268.1 - 12.838 \times (T_{\text{DIE}} - 30^\circ\text{C}) - 2.64\text{e-}3 \times (T_{\text{DIE}} - 30^\circ\text{C})^2 \end{aligned}$$

1.1.2 The First-Order Approximation (Linear)

For a quicker approximation, although less accurate than the second-order, over the full operating temperature range the linear formula below can be used. Using this formula, with the constant and slope in the following set of equations, the best-fit V_{TEMP} vs Die Temperature performance can be calculated with an approximation error less than 18 mV. V_{TEMP} is in mV.

$$\text{GAIN1: } V_{\text{TEMP}} = 1060 - 5.18 \times T_{\text{DIE}}$$

$$\text{GAIN2: } V_{\text{TEMP}} = 1590 - 7.77 \times T_{\text{DIE}}$$

$$\text{GAIN3: } V_{\text{TEMP}} = 2119 - 10.36 \times T_{\text{DIE}}$$

$$\text{GAIN4: } V_{\text{TEMP}} = 2649 - 12.94 \times T_{\text{DIE}}$$

1.1.3 First-Order Approximation (Linear) over Small Temperature Range

For a linear approximation, a line can easily be calculated over the desired temperature range from the Conversion Table using the two-point equation:

$$V - V_1 = \left(\frac{V_2 - V_1}{T_2 - T_1} \right) \times (T - T_1)$$

Where V is in mV, T is in °C, T₁ and V₁ are the coordinates of the lowest temperature, T₂ and V₂ are the coordinates of the highest temperature.

For example, if we want to determine the equation of a line with Gain 4, over a temperature range of 20°C to 50°C, we would proceed as follows:

$$V - 2396 \text{ mV} = \left(\frac{2010 \text{ mV} - 2396 \text{ mV}}{50^\circ\text{C} - 20^\circ\text{C}} \right) \times (T - 20^\circ\text{C})$$

$$V - 2396 \text{ mV} = (-12.8 \text{ mV}/^\circ\text{C}) \times (T - 20^\circ\text{C})$$

$$V = (-12.8 \text{ mV}/^\circ\text{C}) \times (T - 20^\circ\text{C}) + 2396 \text{ mV}$$

Using this method of linear approximation, the transfer function can be approximated for one or more temperature ranges of interest.

2.0 OVERTEMP and $\overline{\text{OVERTEMP}}$ Digital Outputs

The $\overline{\text{OVERTEMP}}$ Active High, Push-Pull Output and the OVERTEMP Active Low, Open-Drain Output both assert at the same time whenever the Die Temperature reaches the factory preset Temperature Trip Point. They also assert simultaneously whenever the TRIP TEST pin is set high. Both outputs de-assert when the die temperature goes below the Temperature Trip Point - Hysteresis. These two types of digital outputs enable the user the flexibility to choose the type of output that is most suitable for his design.

Either the $\overline{\text{OVERTEMP}}$ or the OVERTEMP Digital Output pins can be left open if not used.

2.1 $\overline{\text{OVERTEMP}}$ OPEN-DRAIN DIGITAL OUTPUT

The $\overline{\text{OVERTEMP}}$ Active Low, Open-Drain Digital Output, if used, requires a pull-up resistor between this pin and V_{DD} . The following section shows how to determine the pull-up resistor value.

Determining the Pull-up Resistor Value

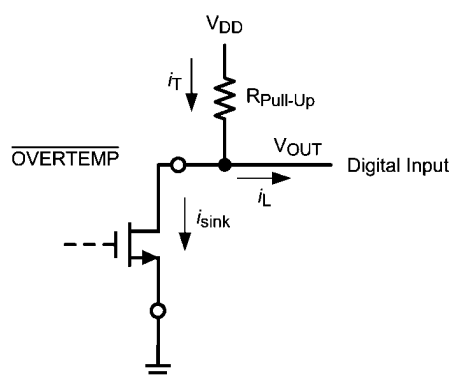

20204752

The Pull-up resistor value is calculated at the condition of maximum total current, i_T , through the resistor. The total current is:

$$i_T = i_L + i_{\text{sink}}$$

where,

i_T i_T is the maximum total current through the Pull-up Resistor at V_{OL} .

i_L i_L is the load current, which is very low for typical digital inputs.

V_{OUT} V_{OUT} is the Voltage at the $\overline{\text{OVERTEMP}}$ pin. Use V_{OL} for calculating the Pull-up resistor.

$V_{DD(\text{Max})}$ $V_{DD(\text{Max})}$ is the maximum power supply voltage to be used in the customer's system.

The pull-up resistor maximum value can be found by using the following formula:

$$R_{\text{pull-up}} = \frac{V_{DD(\text{Max})} - V_{OL}}{i_T}$$

EXAMPLE CALCULATION

Suppose we have, for our example, a V_{DD} of $3.3 \text{ V} \pm 0.3\text{V}$, a CMOS digital input as a load, a V_{OL} of 0.2 V .

(1) We see that for V_{OL} of 0.2 V the electrical specification for $\overline{\text{OVERTEMP}}$ shows a maximum i_{sink} of $385 \mu\text{A}$.

(2) Let $i_L = 1 \mu\text{A}$, then i_T is about $386 \mu\text{A}$ max. If we select $35 \mu\text{A}$ as the current limit then i_T for the calculation becomes $35 \mu\text{A}$

(3) We notice that $V_{DD(\text{Max})}$ is $3.3\text{V} + 0.3\text{V} = 3.6\text{V}$ and then calculate the pull-up resistor as

$$R_{\text{pull-up}} = (3.6 - 0.2)/35 \mu\text{A} = 97\text{k}$$

(4) Based on this calculated value, we select the closest resistor value in the tolerance family we are using.

In our example, if we are using 5% resistor values, then the next closest value is $100 \text{ k}\Omega$.

2.2 NOISE IMMUNITY

The LM26LV is virtually immune from false triggers on the OVERTEMP and $\overline{\text{OVERTEMP}}$ digital outputs due to noise on the power supply. Test have been conducted showing that, with the die temperature within 0.5°C of the temperature trip point, and the severe test of a 3 Vpp square wave "noise" signal injected on the V_{DD} line, over the V_{DD} range of 2V to 5V , there were no false triggers.

3.0 TRIP TEST Digital Input

The TRIP TEST pin simply provides a means to test the OVERTEMP and $\overline{\text{OVERTEMP}}$ digital outputs electronically by causing them to assert, at any operating temperature, as a result of forcing the TRIP TEST pin high.

When the TRIP TEST pin is pulled high the V_{TEMP} pin will be at the V_{TRIP} voltage.

If not used, the TRIP TEST pin may either be left open or grounded.

4.0 V_{TEMP} Analog Temperature Sensor Output

The V_{TEMP} push-pull output provides the ability to sink and source significant current. This is beneficial when, for example, driving dynamic loads like an input stage on an analog-to-digital converter (ADC). In these applications the source current is required to quickly charge the input capacitor of the ADC. See the Applications Circuits section for more discussion of this topic. The LM26LV is ideal for this and other applications which require strong source or sink current.

4.1 NOISE CONSIDERATIONS

The LM26LV's supply-noise rejection (the ratio of the AC signal on V_{TEMP} to the AC signal on V_{DD}) was measured during bench tests. It's typical attenuation is shown in the Typical Performance Characteristics section. A load capacitor on the output can help to filter noise.

For operation in very noisy environments, some bypass capacitance should be present on the supply within approximately 2 inches of the LM26LV.

4.2 CAPACITIVE LOADS

The V_{TEMP} Output handles capacitive loading well. In an extremely noisy environment, or when driving a switched sampling input on an ADC, it may be necessary to add some filtering to minimize noise coupling. Without any precautions, the V_{TEMP} can drive a capacitive load less than or equal to 1100 pF as shown in [Figure 1](#). For capacitive loads greater than 1100 pF , a series resistor is required on the output, as shown in [Figure 2](#), to maintain stable conditions.

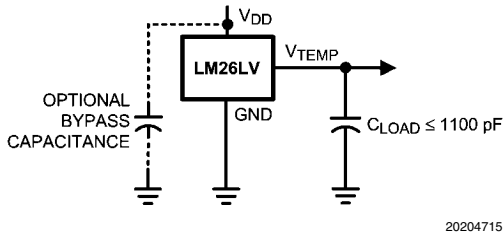
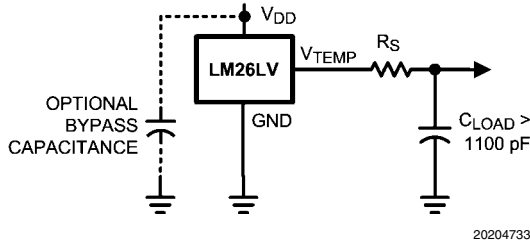

FIGURE 1. LM26LV No Decoupling Required for Capacitive Loads Less than 1100 pF.



| C _{LOAD} | Minimum R _S |
|-------------------|------------------------|
| 1.1 nF to 99 nF | 3 kΩ |
| 100 nF to 999 nF | 1.5 kΩ |
| 1 μF | 800 Ω |

FIGURE 2. LM26LV with series resistor for capacitive loading greater than 1100 pF.

4.3 VOLTAGE SHIFT

The LM26LV is very linear over temperature and supply voltage range. Due to the intrinsic behavior of an NMOS/PMOS rail-to-rail buffer, a slight shift in the output can occur when the supply voltage is ramped over the operating range of the device. The location of the shift is determined by the relative levels of V_{DD} and V_{TEMP}. The shift typically occurs when V_{DD} - V_{TEMP} = 1.0V.

This slight shift (a few millivolts) takes place over a wide change (approximately 200 mV) in V_{DD} or V_{TEMP}. Since the shift takes place over a wide temperature change of 5°C to 20°C, V_{TEMP} is always monotonic. The accuracy specifications in the Electrical Characteristics table already includes this possible shift.

5.0 Mounting and Temperature Conductivity

The LM26LV can be applied easily in the same way as other integrated-circuit temperature sensors. It can be glued or cemented to a surface.

The best thermal conductivity between the device and the PCB is achieved by soldering the DAP of the package to the thermal pad on the PCB. The temperatures of the lands and traces to the other leads of the LM26LV will also affect the temperature reading.

Alternatively, the LM26LV can be mounted inside a sealed-end metal tube, and can then be dipped into a bath or screwed into a threaded hole in a tank. As with any IC, the LM26LV and accompanying wiring and circuits must be kept insulated and dry, to avoid leakage and corrosion. This is especially true if the circuit may operate at cold temperatures where condensation can occur. If moisture creates a short circuit from the V_{TEMP} output to ground or V_{DD}, the V_{TEMP} output from the LM26LV will not be correct. Printed-circuit coatings are often used to ensure that moisture cannot corrode the leads or circuit traces.

The thermal resistance junction-to-ambient (θ_{JA}) is the parameter used to calculate the rise of a device junction temperature due to its power dissipation. The equation used to calculate the rise in the LM26LV's die temperature is

$$T_J = T_A + \theta_{JA} [(V_{DD}I_Q) + (V_{DD} - V_{TEMP}) I_L]$$

where T_A is the ambient temperature, I_Q is the quiescent current, I_L is the load current on the output, and V_O is the output voltage. For example, in an application where T_A = 30 °C, V_{DD} = 5 V, I_{DD} = 9 μA, Gain 4, V_{TEMP} = 2231 mV, and I_L = 2 μA, the junction temperature would be 30.021 °C, showing a self-heating error of only 0.021°C. Since the LM26LV's junction temperature is the actual temperature being measured, care should be taken to minimize the load current that the V_{TEMP} output is required to drive. If the OVERTEMP output is asserted (low), then for this example the additional contribution is [(152° C/W)x(5V)²/100k] = 0.038°C for a total self-heating error of 0.059°C. Figure 3 shows the thermal resistance of the LM26LV.

| Device Number | NS Package Number | Thermal Resistance (θ _{JA}) |
|---------------|-------------------|---------------------------------------|
| LM26LVCISD | SDB06A | 152° C/W |

FIGURE 3. LM26LV Thermal Resistance

6.0 Applications Circuits

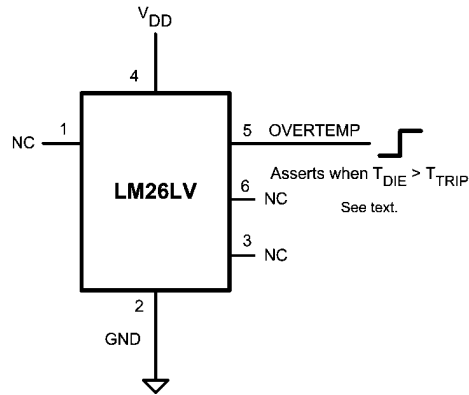

20204761

FIGURE 4. Temperature Switch Using Push-Pull Output

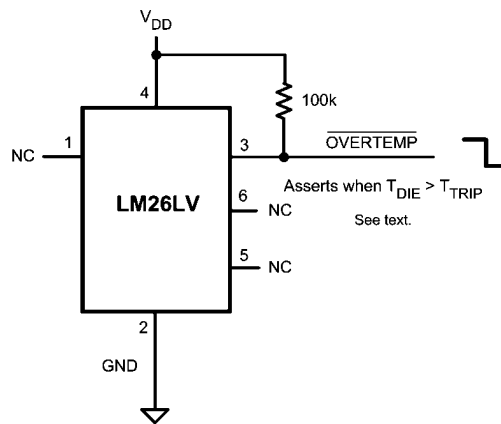

20204762

FIGURE 5. Temperature Switch Using Open-Drain Output

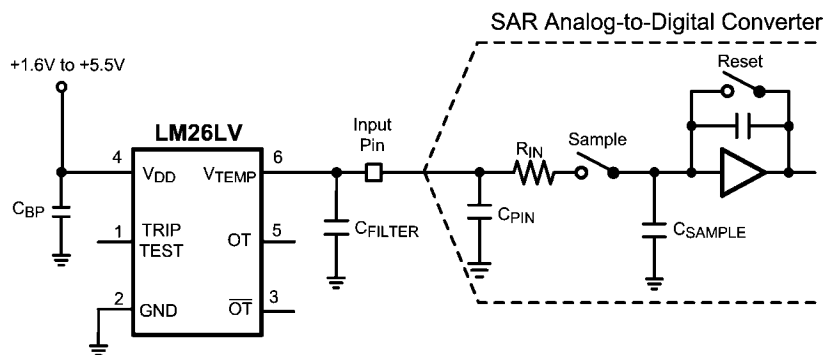

20204728

Most CMOS ADCs found in microcontrollers and ASICs have a sampled data comparator input structure. When the ADC charges the sampling cap, it requires instantaneous charge from the output of the analog source such as the LM26LV temperature sensor and many op amps. This requirement is easily accommodated by the addition of a capacitor (C_{FILTER}). The size of C_{FILTER} depends on the size of the sampling capacitor and the sampling frequency. Since not all ADCs have identical input stages, the charge requirements will vary. This general ADC application is shown as an example only.

FIGURE 6. Suggested Connection to a Sampling Analog-to-Digital Converter Input Stage

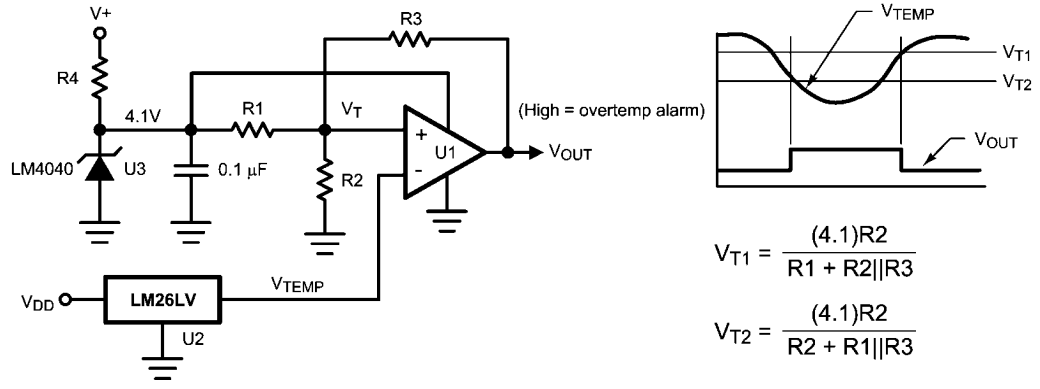

$$V_{T1} = \frac{(4.1)R2}{R1 + R2 || R3}$$

$$V_{T2} = \frac{(4.1)R2}{R2 + R1 || R3}$$

20204718

FIGURE 7. Celsius Temperature Switch

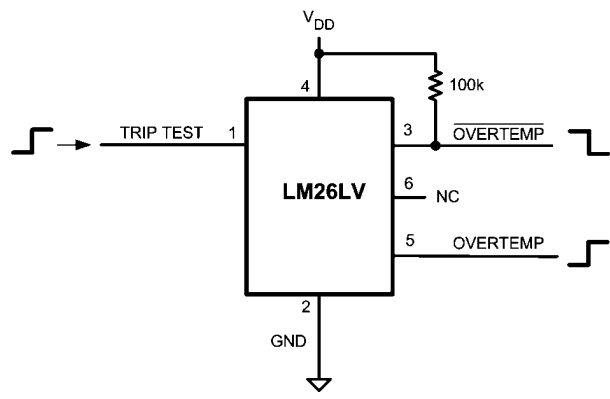

20204760

FIGURE 8. TRIP TEST Digital Output Test Circuit

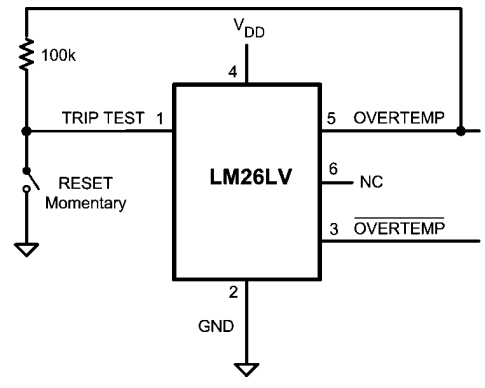

20204765

The TRIP TEST pin, normally used to check the operation of the OVERTEMP and $\overline{\text{OVERTEMP}}$ pins, may be used to latch the outputs whenever the temperature exceeds the programmed limit and causes the digital outputs to assert. As shown in the figure, when OVERTEMP goes high the TRIP TEST input is also pulled high and causes OVERTEMP output to latch high and the $\overline{\text{OVERTEMP}}$ output to latch low. The latch can be released by either momentarily pulling the TRIP TEST pin low (GND), or by toggling the power supply to the device. The resistor limits the current out of the OVERTEMP output pin.

FIGURE 9. Latch Circuit using OVERTEMP Output

Notes

For more National Semiconductor product information and proven design tools, visit the following Web sites at:
www.national.com

| Products | | Design Support | |
|--------------------------------|--|------------------------------|--|
| Amplifiers | www.national.com/amplifiers | WEBENCH® Tools | www.national.com/webench |
| Audio | www.national.com/audio | App Notes | www.national.com/appnotes |
| Clock and Timing | www.national.com/timing | Reference Designs | www.national.com/refdesigns |
| Data Converters | www.national.com/adc | Samples | www.national.com/samples |
| Interface | www.national.com/interface | Eval Boards | www.national.com/evalboards |
| LVDS | www.national.com/lvds | Packaging | www.national.com/packaging |
| Power Management | www.national.com/power | Green Compliance | www.national.com/quality/green |
| Switching Regulators | www.national.com/switchers | Distributors | www.national.com/contacts |
| LDOs | www.national.com/ldo | Quality and Reliability | www.national.com/quality |
| LED Lighting | www.national.com/led | Feedback/Support | www.national.com/feedback |
| Voltage References | www.national.com/vref | Design Made Easy | www.national.com/easy |
| PowerWise® Solutions | www.national.com/powerwise | Applications & Markets | www.national.com/solutions |
| Serial Digital Interface (SDI) | www.national.com/sdi | Mil/Aero | www.national.com/milaero |
| Temperature Sensors | www.national.com/tempsensors | SolarMagic™ | www.national.com/solarmagic |
| PLL/VCO | www.national.com/wireless | PowerWise® Design University | www.national.com/training |

THE CONTENTS OF THIS DOCUMENT ARE PROVIDED IN CONNECTION WITH NATIONAL SEMICONDUCTOR CORPORATION ("NATIONAL") PRODUCTS. NATIONAL MAKES NO REPRESENTATIONS OR WARRANTIES WITH RESPECT TO THE ACCURACY OR COMPLETENESS OF THE CONTENTS OF THIS PUBLICATION AND RESERVES THE RIGHT TO MAKE CHANGES TO SPECIFICATIONS AND PRODUCT DESCRIPTIONS AT ANY TIME WITHOUT NOTICE. NO LICENSE, WHETHER EXPRESS, IMPLIED, ARISING BY ESTOPPEL OR OTHERWISE, TO ANY INTELLECTUAL PROPERTY RIGHTS IS GRANTED BY THIS DOCUMENT.

TESTING AND OTHER QUALITY CONTROLS ARE USED TO THE EXTENT NATIONAL DEEMS NECESSARY TO SUPPORT NATIONAL'S PRODUCT WARRANTY. EXCEPT WHERE MANDATED BY GOVERNMENT REQUIREMENTS, TESTING OF ALL PARAMETERS OF EACH PRODUCT IS NOT NECESSARILY PERFORMED. NATIONAL ASSUMES NO LIABILITY FOR APPLICATIONS ASSISTANCE OR BUYER PRODUCT DESIGN. BUYERS ARE RESPONSIBLE FOR THEIR PRODUCTS AND APPLICATIONS USING NATIONAL COMPONENTS. PRIOR TO USING OR DISTRIBUTING ANY PRODUCTS THAT INCLUDE NATIONAL COMPONENTS, BUYERS SHOULD PROVIDE ADEQUATE DESIGN, TESTING AND OPERATING SAFEGUARDS.

EXCEPT AS PROVIDED IN NATIONAL'S TERMS AND CONDITIONS OF SALE FOR SUCH PRODUCTS, NATIONAL ASSUMES NO LIABILITY WHATSOEVER, AND NATIONAL DISCLAIMS ANY EXPRESS OR IMPLIED WARRANTY RELATING TO THE SALE AND/OR USE OF NATIONAL PRODUCTS INCLUDING LIABILITY OR WARRANTIES RELATING TO FITNESS FOR A PARTICULAR PURPOSE, MERCHANTABILITY, OR INFRINGEMENT OF ANY PATENT, COPYRIGHT OR OTHER INTELLECTUAL PROPERTY RIGHT.

LIFE SUPPORT POLICY

NATIONAL'S PRODUCTS ARE NOT AUTHORIZED FOR USE AS CRITICAL COMPONENTS IN LIFE SUPPORT DEVICES OR SYSTEMS WITHOUT THE EXPRESS PRIOR WRITTEN APPROVAL OF THE CHIEF EXECUTIVE OFFICER AND GENERAL COUNSEL OF NATIONAL SEMICONDUCTOR CORPORATION. As used herein:

Life support devices or systems are devices which (a) are intended for surgical implant into the body, or (b) support or sustain life and whose failure to perform when properly used in accordance with instructions for use provided in the labeling can be reasonably expected to result in a significant injury to the user. A critical component is any component in a life support device or system whose failure to perform can be reasonably expected to cause the failure of the life support device or system or to affect its safety or effectiveness.

National Semiconductor and the National Semiconductor logo are registered trademarks of National Semiconductor Corporation. All other brand or product names may be trademarks or registered trademarks of their respective holders.

Copyright© 2010 National Semiconductor Corporation

For the most current product information visit us at www.national.com



National Semiconductor Americas Technical Support Center
 Email: support@nsc.com
 Tel: 1-800-272-9959

National Semiconductor Europe Technical Support Center
 Email: europe.support@nsc.com

National Semiconductor Asia Pacific Technical Support Center
 Email: ap.support@nsc.com

National Semiconductor Japan Technical Support Center
 Email: jpn.feedback@nsc.com