

# LM2780

*LM2780 Ultra-Low Ripple Switched Capacitor Voltage Inverter*



Literature Number: SNVS200B

# Ultra-Low Ripple Switched Capacitor Voltage Inverter

## General Description

The LM2780 is a charge pump that inverts an input voltage in the range of 1.8V to 5.5V to the corresponding output voltage of -1.8V to -5.5V. With use of three or four low-cost external ceramic capacitors, the LM2780 can provide up to 50mA of output current.

The LM2780 operates at a 12kHz typical switching frequency to minimize supply current (60µA typ.). Two charge pumps operate 180° out of phase to significantly reduce the output voltage ripple compared to that of traditional single-phase charge pump circuits. If larger output ripple can be tolerated, optional capacitor C2 may be omitted to reduce the cost and size of the solution. The LM2780 is available in an 8-pin Micro SMD chip-scale package.

See also: LM2781, a fast clock (210kHz typ) version of this topology with even lower output voltage ripple.

## Features

- Inverts Input Voltage
- Ultra-Low Voltage Ripple and 8Ω Typical Output Resistance with Two Flying Capacitors
- Output Resistance of 18Ω Using One Flying Capacitor
- 12kHz (typ.) Switching Frequency
- 8-pin micro SMD Package (1.4mm × 1.4mm × 0.5mm)

## Applications

- Cellular Phones
- Pagers
- PDAs
- Op-Amp Power Supplies
- Interface Power Supplies
- Handheld Instruments

## Typical Application Circuit

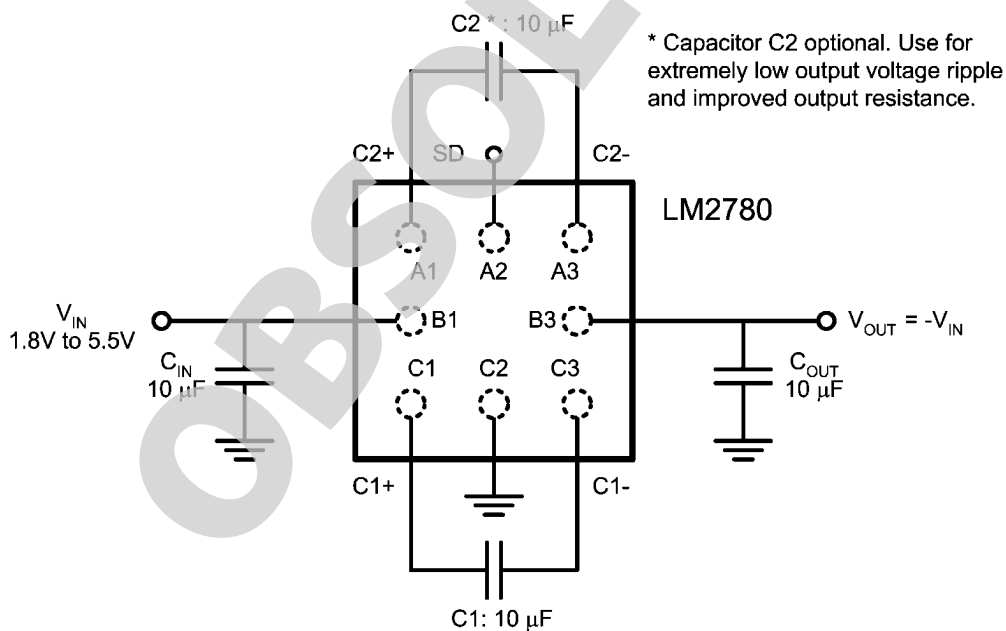

20044601

## Connection Diagram

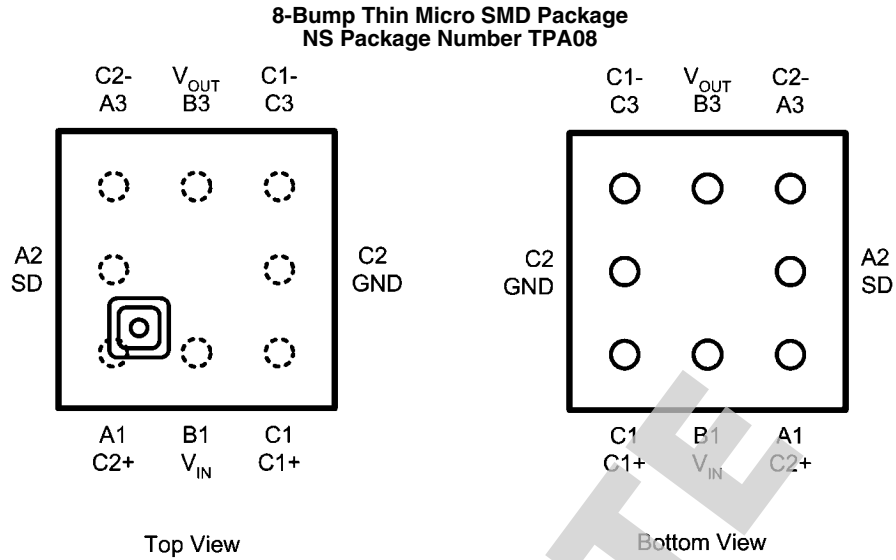

20044602

## Pin Descriptions

Pin	Name	Description
A1	C2+	Secondary flying-capacitor connection
B1	$V_{IN}$	Input voltage. Input range: 1.8V to 5.5V
C1	C1+	Primary flying-capacitor connection
A2	SD	Shutdown pin logic input. Low = on, High = shutdown
C2	GND	Ground
A3	C2-	Secondary flying-capacitor connection
B3	$V_{OUT}$	Output voltage. $V_{OUT} = -V_{IN}$
C3	C1-	Primary flying capacitor connection

## Ordering Information

Order Number	Package Description	Package Marking	Supplied as
LM2780TP	TPA08: Thin Micro SMD	11	Tape and reel, 250 pcs.
LM2780TPX	TPA08: Thin Micro SMD	11	Tape and reel, 3000 pcs.

## Absolute Maximum Ratings (Note 1, Note 2)

If Military/Aerospace specified devices are required, please contact the National Semiconductor Sales Office/ Distributors for availability and specifications.

$V_{IN}$ pin: Voltage to GND	-0.3V to 5.8V
SD pin: Voltage to GND	-0.3V to $(V_{IN} + 0.3V)$ , with 5.8V max
Output Short-to-GND Duration <small>(Note 3)</small>	1 sec.
Maximum Junction Temperature $(T_{J-MAX})$	150°C
Storage Temperature Range	-65°C to +150°C

Pad Temperature <small>(Soldering, 10 sec.)</small>	265°C
ESD Rating <small>(Note 4)</small>	
Human-body model	2kV
Machine model	200V

## Operating Ratings (Note 1, Note 2)

Input Voltage Range	1.8V to 5.5V
Junction Temperature $(T_J)$ Range	-40°C to +90°C
Ambient Temperature $(T_A)$ Range <small>(Note 5)</small>	-40°C to +85°C

## Thermal Properties

Junction-to-Ambient Thermal Resistance $(\theta_{JA})$ , TPA08 Package <small>(Note 6)</small>	220°C/W
--	---------

## Electrical Characteristics (Note 2, Note 7)

Limits in standard typface are for  $T_J = 25^\circ\text{C}$ , and limits in **boldface** type apply over the full operating junction temperature range  $(-40^\circ\text{C} \leq T_J \leq +90^\circ\text{C})$ . Unless otherwise noted: specifications apply to the LM2780 Typical Application Circuit (pg. 1) with  $V_{IN} = 5.0\text{V}$ ,  $V(\text{SD}) = 0\text{V}$ , and  $C_{IN} = C_{OUT} = C1 = C2 = 10\mu\text{F}$ . (Note 8)

Symbol	Parameter	Conditions	Min	Typ	Max	Units
$R_{OUT}$	Output Resistance <small>(Note 9)</small>	$I_{OUT} = 10\text{mA}$ , $C2 = 10\mu\text{F}$		8	<b>30</b>	$\Omega$
		$I_{OUT} = 10\text{mA}$ , C2 removed		18	<b>40</b>	$\Omega$
$I_Q$	Supply Current	No load		60	<b>120</b>	$\mu\text{A}$
$I_{SD}$	Shutdown Supply Current	$V(\text{SD}) = 5.0\text{V}$		0.1	<b>0.5</b>	$\mu\text{A}$
$F_{SW}$	Switching Frequency		<b>6</b>	12	<b>28</b>	kHz
$V_{SD}$	Shutdown Pin Logic Levels	Normal Operation $1.8\text{V} \leq V_{IN} \leq 5.5\text{V}$	<b>0</b>		<b>0.5</b>	V
		Shutdown Mode $1.8\text{V} \leq V_{IN} \leq 5.5\text{V}$	<b><math>0.5 \times V_{IN}</math></b>		<b><math>V_{IN}</math></b>	
$V_{OUTP-P}$	Output Voltage Ripple	$V_{IN} = 5.0\text{V}$ , $I_{OUT} = 10\text{mA}$		40		mV
$P_{EFF}$	Power Efficiency	$V_{IN} = 5.0\text{V}$ , $I_{OUT} = 10\text{mA}$		98		%

**Note 1:** Absolute Maximum Ratings indicate limits beyond which damage to the component may occur. Operating Ratings are conditions under which operation of the device is guaranteed. Operating Ratings do not imply guaranteed performance limits. For guaranteed performance limits and associated test conditions, see the Electrical Characteristics table.

**Note 2:** All voltages are with respect to the potential at the GND pin.

**Note 3:**  $V_{OUT}$  may be shorted to GND for one second without damage when the ambient temperature is at or below 85°C. Prolonged or repeated shorts of  $V_{OUT}$  to GND may damage the device, and should be avoided.

**Note 4:** The human-body model is a 100pF capacitor discharged through a 1.5k $\Omega$  resistor into each pin. The machine model is a 200pF capacitor discharged directly into each pin.

**Note 5:** Maximum ambient temperature  $(T_{A-MAX})$  is dependent on the maximum operating junction temperature  $(T_{J-MAX-OP} = 90^\circ\text{C})$ , the maximum power dissipation of the device in the application  $(P_{D-MAX})$ , and the junction-to-ambient thermal resistance of the part in the application  $(\theta_{JA})$ , as given by the following equation:  
 $T_{A-MAX} = T_{J-MAX-OP} - (\theta_{JA} \times P_{D-MAX})$ .

**Note 6:** Junction-to-ambient thermal resistance of the micro SMD package is highly application and board-layout dependent.

**Note 7:** Max and Min limits are guaranteed by design, test, or statistical analysis. Typical numbers are not guaranteed, but do represent the most likely norm.

**Note 8:**  $C_{IN}$ ,  $C_{OUT}$ , C1, and C2: Low-ESR Surface-Mount Ceramic Capacitors (MLCCs) used in setting electrical characteristics.

**Note 9:** Output resistance is a model for the voltage drop at the output, resulting from internal switch resistance, capacitor ESR, and charge pump charge transfer characteristics. Output voltage can be predicted with the following equation:  $V_{OUT} = -[V_{IN} - (I_{OUT} \times R_{OUT})]$

## Typical Performance Characteristics

Unless otherwise specified,  $T_A = 25^\circ\text{C}$ ,  $C_{IN} = C_{OUT} = C1 = C2 = 10\mu\text{F}$ .

### Output Voltage vs. Load Current

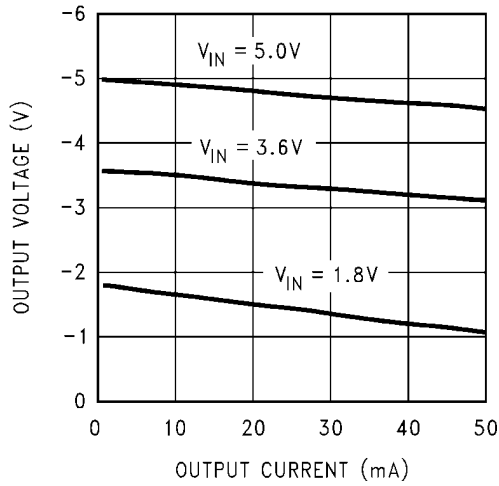

### Power Efficiency vs. Load Current

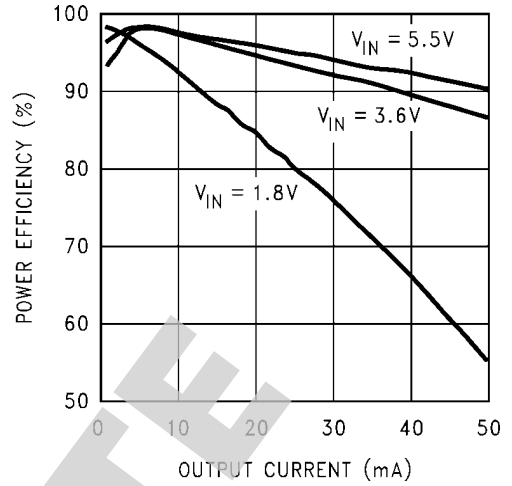

### Output Resistance vs. Temperature ( $I_{OUT} = 10\text{mA}$ )

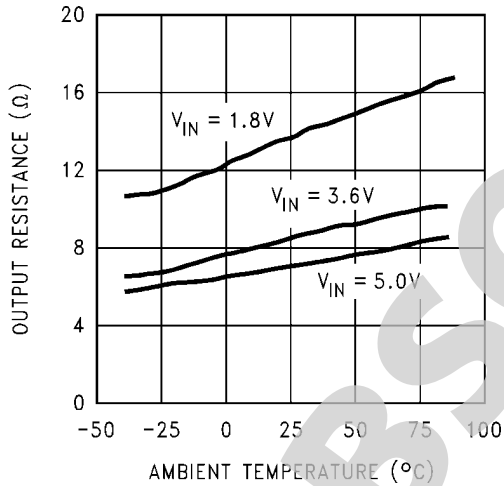

### Supply Current vs. Temperature ( $I_{OUT} = 0$ )

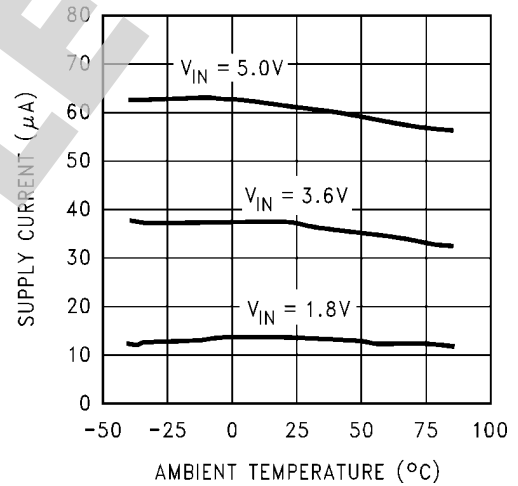

### Switching Frequency vs. Temperature

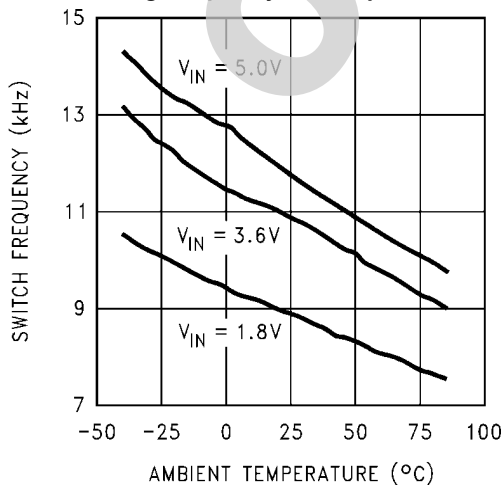

### Output Voltage Ripple vs. Output Current

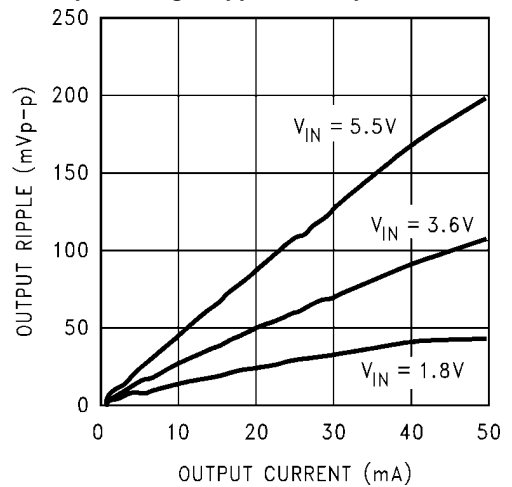

## Block Diagram

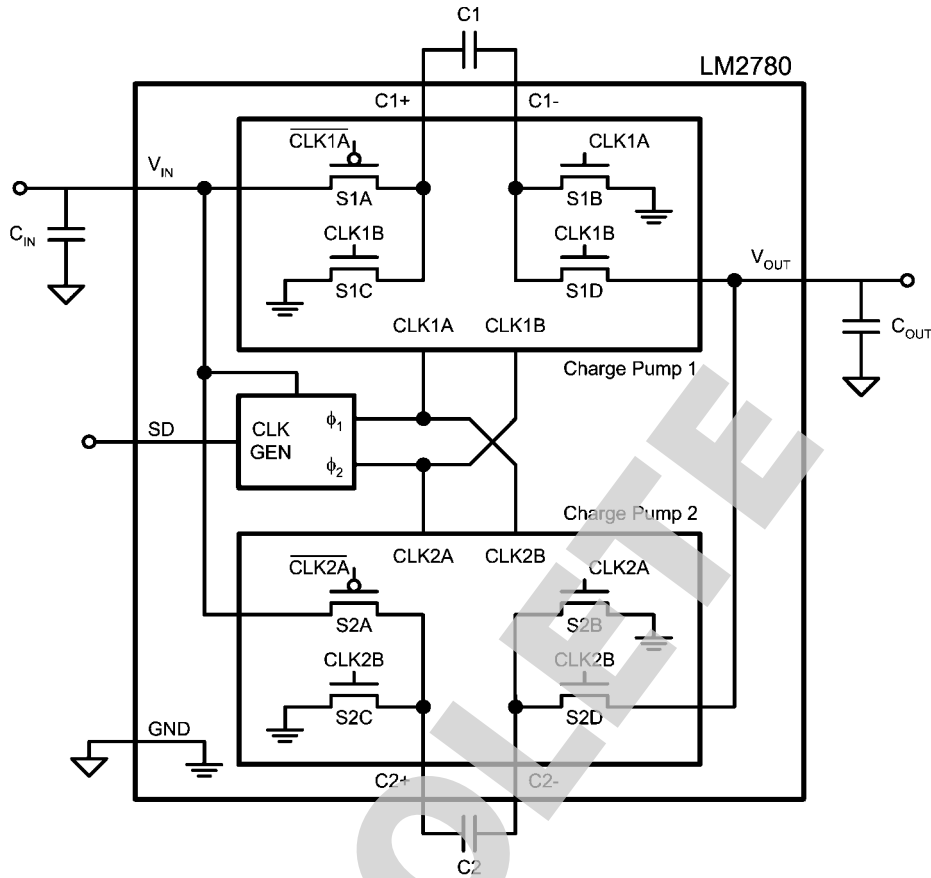

20044610

## Operation Description

The LM2780 is a switched capacitor voltage inverter that produces a negative output voltage from a positive input voltage. To minimize output voltage ripple, the LM2780 contains two charge pump inverters that operate 180° out of phase. These two charge pumps can be seen in the block diagram above.

A basic switched capacitor inverter is a two-phase charge pump circuit that transfers charge from the input to the output using a flying capacitor. Charge Pump 1 in the block diagram will be used to illustrate the operation of a single charge pump. Disregard Charge Pump 2 in the diagram for now. In phase 1 ( $\phi_1$ ), the CLK1A signal of Charge Pump 1 is high, and MOSFET switches S1A and S1B are ON. For Charge Pump 1, this is the charge phase, as the flying capacitor C1 is charged to the input voltage. In the second phase ( $\phi_2$ ), the positive-charged plate of C1 is connected to GND through switch S1C, and the negative-charged plate is connected to the output through switch S1D. This results in the output voltage being approximately equal in magnitude to the input voltage, but opposite in sign ( $V_{OUT} \approx -V_{IN}$ ). In this pump phase, charge stored on the flying capacitor supplies the current to the load and transfers charge to the output capacitor.

This basic inverter has ripple in the output voltage. During the charge phase, the load current is supplied by the charge on the output capacitor. As charge is pulled off  $C_{OUT}$ , the voltage across the capacitor drops, and the magnitude of the output voltage ( $|V_{OUT}|$ ) falls. During the pump phase, the flying ca-

pacitor transfers charge to the  $C_{OUT}$ , elevating both the voltage across the  $C_{OUT}$  and the magnitude of the output voltage.

The LM2780 contains two charge pump inverters running 180° out of phase. Notice in the block diagram that the clock connections on Charge Pump 2 are opposite of the clock connections on Charge Pump 1. Thus, when Charge Pump 1 is in the charge phase, Charge Pump 2 is in the pump phase, and vice-versa. With this double-pump technology, there is always a flying capacitor connected to the output. This results in significantly lower output voltage ripple than that of a single-pump inverter.

### OUTPUT VOLTAGE RIPPLE

Several factors influence the magnitude of voltage ripple on the output of the LM2780. Primary influences are output capacitance, flying capacitance, load current, input voltage, and output capacitor ESR.

The magnitude of the output voltage ripple is difficult to predict with equations when the LM2780 is double pumping. Refer to the Typical Performance Characteristic curves for this information. In general, ripple decreases with increased output capacitance, decreased load current, a lower input voltage, a smaller flying capacitance and/or a smaller output capacitor ESR.

When only one charge pump is active (C2 removed), the output ripple is more predictable, and can be estimated with the following equation:

$$V_{RIPPLE} = [(0.5 \times I_{OUT}) / (f_{SW} \times C_{OUT})] + (2 \times I_{OUT} \times ESR_{C_{OUT}})$$

## OUTPUT RESISTANCE

Output resistance ( $R_{OUT}$ ) models the internal non-idealities of a charge pump that result in droop in the output voltage. The effect of output resistance on output voltage is expressed in the following equation:

$$V_{OUT} = - [V_{IN} - (|I_{OUT}| \times R_{OUT})]$$

Output resistance is a function of the internal switch resistance ( $R_{SW}$ ), flying capacitance (C1), flying capacitor equivalent series resistance ( $ESR_{C1}$ ), output capacitor ESR ( $ESR_{Cout}$ ), and internal switching frequency ( $f_{SW}$ ). When the LM2780 operates as a single charge pump (C2 removed), the output resistance can be approximated by the following equation:

$$1 \text{ Fly Cap: } R_{OUT1} \approx 2R_{SW1} + [1/(f_{SW} \times C1)] + 4ESR_{C1} + ESR_{Cout}$$

$R_{SW1}$  is the sum of the ON resistance of the four internal MOSFET switches of Charge Pump 1.

With both C1 and C2 in place, the double pumping topology of the LM2780 cuts the output resistance in half:

$$2 \text{ Fly Caps: } R_{OUT2} \approx 0.5 \times R_{OUT1}$$

Recommendations for minimizing output resistance include increasing flying capacitance and minimizing output and flying capacitor ESR.

## CAPACITOR SELECTION

Surface-mount multi-layer ceramic capacitors are recommended for use with the LM2780. These capacitors are small,

inexpensive and have very low equivalent series resistance (ESR, < 15mΩ typ.). Tantalum capacitors, OS-CON capacitors, and aluminum electrolytic capacitors generally are not recommended for use with the LM2780 due to their high ESR, as compared to ceramic capacitors.

For most applications, ceramic capacitors with X7R or X5R temperature characteristic are preferred for use with the LM2780. These capacitors have tight capacitance tolerance (as good as ±10%), hold their value over temperature (X7R: ±15% over -55°C to 125°C; X5R: ±15% over -55°C to 85°C), and typically have little voltage coefficient.

Capacitors with Y5V and/or Z5U temperature characteristic are generally not recommended for use with the LM2780. These types of capacitors typically have wide capacitance tolerance (+80%, -20%), vary significantly over temperature (Y5V: +22%, -82% over -30°C to +85°C range; Z5U: +22%, -56% over +10°C to +85°C range), and have poor voltage coefficients. Under some conditions, a nominal 1μF Y5V or Z5U capacitor could have a capacitance of only 0.1μF. Such deviation would severely affect performance of the LM2780 circuit.

OBSOLETE

**Physical Dimensions** inches (millimeters) unless otherwise noted

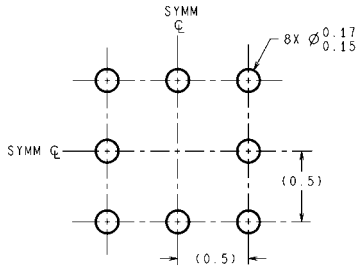

DIMENSIONS ARE IN MILLIMETERS  
DIMENSIONS IN ( ) FOR REFERENCE ONLY

**LAND PATTERN RECOMMENDATION**

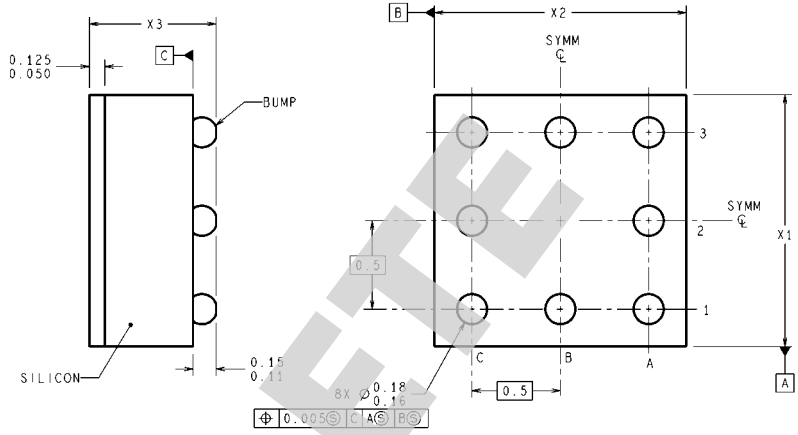
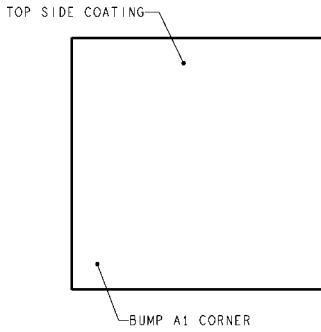

TPA08XXX (Rev B)

**TPA08: 8-Bump Thin Micro SMD**  
**X1 = X2 = 1.361mm ± 0.030mm**  
**X3 = 0.500mm ± 0.075mm**

OBSOLETE

## Notes

For more National Semiconductor product information and proven design tools, visit the following Web sites at:  
[www.national.com](http://www.national.com)

Products		Design Support	
Amplifiers	<a href="http://www.national.com/amplifiers">www.national.com/amplifiers</a>	WEBENCH® Tools	<a href="http://www.national.com/webench">www.national.com/webench</a>
Audio	<a href="http://www.national.com/audio">www.national.com/audio</a>	App Notes	<a href="http://www.national.com/appnotes">www.national.com/appnotes</a>
Clock and Timing	<a href="http://www.national.com/timing">www.national.com/timing</a>	Reference Designs	<a href="http://www.national.com/refdesigns">www.national.com/refdesigns</a>
Data Converters	<a href="http://www.national.com/adc">www.national.com/adc</a>	Samples	<a href="http://www.national.com/samples">www.national.com/samples</a>
Interface	<a href="http://www.national.com/interface">www.national.com/interface</a>	Eval Boards	<a href="http://www.national.com/evalboards">www.national.com/evalboards</a>
LVDS	<a href="http://www.national.com/lvds">www.national.com/lvds</a>	Packaging	<a href="http://www.national.com/packaging">www.national.com/packaging</a>
Power Management	<a href="http://www.national.com/power">www.national.com/power</a>	Green Compliance	<a href="http://www.national.com/quality/green">www.national.com/quality/green</a>
Switching Regulators	<a href="http://www.national.com/switchers">www.national.com/switchers</a>	Distributors	<a href="http://www.national.com/contacts">www.national.com/contacts</a>
LDOs	<a href="http://www.national.com/ldo">www.national.com/ldo</a>	Quality and Reliability	<a href="http://www.national.com/quality">www.national.com/quality</a>
LED Lighting	<a href="http://www.national.com/led">www.national.com/led</a>	Feedback/Support	<a href="http://www.national.com/feedback">www.national.com/feedback</a>
Voltage References	<a href="http://www.national.com/vref">www.national.com/vref</a>	Design Made Easy	<a href="http://www.national.com/easy">www.national.com/easy</a>
PowerWise® Solutions	<a href="http://www.national.com/powerwise">www.national.com/powerwise</a>	Applications & Markets	<a href="http://www.national.com/solutions">www.national.com/solutions</a>
Serial Digital Interface (SDI)	<a href="http://www.national.com/sdi">www.national.com/sdi</a>	Mil/Aero	<a href="http://www.national.com/milaero">www.national.com/milaero</a>
Temperature Sensors	<a href="http://www.national.com/tempensors">www.national.com/tempensors</a>	SolarMagic™	<a href="http://www.national.com/solarmagic">www.national.com/solarmagic</a>
PLL/VCO	<a href="http://www.national.com/wireless">www.national.com/wireless</a>	PowerWise® Design University	<a href="http://www.national.com/training">www.national.com/training</a>

THE CONTENTS OF THIS DOCUMENT ARE PROVIDED IN CONNECTION WITH NATIONAL SEMICONDUCTOR CORPORATION ("NATIONAL") PRODUCTS. NATIONAL MAKES NO REPRESENTATIONS OR WARRANTIES WITH RESPECT TO THE ACCURACY OR COMPLETENESS OF THE CONTENTS OF THIS PUBLICATION AND RESERVES THE RIGHT TO MAKE CHANGES TO SPECIFICATIONS AND PRODUCT DESCRIPTIONS AT ANY TIME WITHOUT NOTICE. NO LICENSE, WHETHER EXPRESS, IMPLIED, ARISING BY ESTOPPEL OR OTHERWISE, TO ANY INTELLECTUAL PROPERTY RIGHTS IS GRANTED BY THIS DOCUMENT.

TESTING AND OTHER QUALITY CONTROLS ARE USED TO THE EXTENT NATIONAL DEEMS NECESSARY TO SUPPORT NATIONAL'S PRODUCT WARRANTY. EXCEPT WHERE MANDATED BY GOVERNMENT REQUIREMENTS, TESTING OF ALL PARAMETERS OF EACH PRODUCT IS NOT NECESSARILY PERFORMED. NATIONAL ASSUMES NO LIABILITY FOR APPLICATIONS ASSISTANCE OR BUYER PRODUCT DESIGN. BUYERS ARE RESPONSIBLE FOR THEIR PRODUCTS AND APPLICATIONS USING NATIONAL COMPONENTS. PRIOR TO USING OR DISTRIBUTING ANY PRODUCTS THAT INCLUDE NATIONAL COMPONENTS, BUYERS SHOULD PROVIDE ADEQUATE DESIGN, TESTING AND OPERATING SAFEGUARDS.

EXCEPT AS PROVIDED IN NATIONAL'S TERMS AND CONDITIONS OF SALE FOR SUCH PRODUCTS, NATIONAL ASSUMES NO LIABILITY WHATSOEVER, AND NATIONAL DISCLAIMS ANY EXPRESS OR IMPLIED WARRANTY RELATING TO THE SALE AND/OR USE OF NATIONAL PRODUCTS INCLUDING LIABILITY OR WARRANTIES RELATING TO FITNESS FOR A PARTICULAR PURPOSE, MERCHANTABILITY, OR INFRINGEMENT OF ANY PATENT, COPYRIGHT OR OTHER INTELLECTUAL PROPERTY RIGHT.

#### LIFE SUPPORT POLICY

**NATIONAL'S PRODUCTS ARE NOT AUTHORIZED FOR USE AS CRITICAL COMPONENTS IN LIFE SUPPORT DEVICES OR SYSTEMS WITHOUT THE EXPRESS PRIOR WRITTEN APPROVAL OF THE CHIEF EXECUTIVE OFFICER AND GENERAL COUNSEL OF NATIONAL SEMICONDUCTOR CORPORATION.** As used herein:

Life support devices or systems are devices which (a) are intended for surgical implant into the body, or (b) support or sustain life and whose failure to perform when properly used in accordance with instructions for use provided in the labeling can be reasonably expected to result in a significant injury to the user. A critical component is any component in a life support device or system whose failure to perform can be reasonably expected to cause the failure of the life support device or system or to affect its safety or effectiveness.

National Semiconductor and the National Semiconductor logo are registered trademarks of National Semiconductor Corporation. All other brand or product names may be trademarks or registered trademarks of their respective holders.

Copyright© 2011 National Semiconductor Corporation

For the most current product information visit us at [www.national.com](http://www.national.com)



[www.national.com](http://www.national.com)

**National Semiconductor  
Americas Technical  
Support Center**  
Email: [support@nsc.com](mailto:support@nsc.com)  
Tel: 1-800-272-9959

**National Semiconductor Europe  
Technical Support Center**  
Email: [europe.support@nsc.com](mailto:europe.support@nsc.com)

**National Semiconductor Asia  
Pacific Technical Support Center**  
Email: [ap.support@nsc.com](mailto:ap.support@nsc.com)

**National Semiconductor Japan  
Technical Support Center**  
Email: [jpn.feedback@nsc.com](mailto:jpn.feedback@nsc.com)

## IMPORTANT NOTICE

Texas Instruments Incorporated and its subsidiaries (TI) reserve the right to make corrections, modifications, enhancements, improvements, and other changes to its products and services at any time and to discontinue any product or service without notice. Customers should obtain the latest relevant information before placing orders and should verify that such information is current and complete. All products are sold subject to TI's terms and conditions of sale supplied at the time of order acknowledgment.

TI warrants performance of its hardware products to the specifications applicable at the time of sale in accordance with TI's standard warranty. Testing and other quality control techniques are used to the extent TI deems necessary to support this warranty. Except where mandated by government requirements, testing of all parameters of each product is not necessarily performed.

TI assumes no liability for applications assistance or customer product design. Customers are responsible for their products and applications using TI components. To minimize the risks associated with customer products and applications, customers should provide adequate design and operating safeguards.

TI does not warrant or represent that any license, either express or implied, is granted under any TI patent right, copyright, mask work right, or other TI intellectual property right relating to any combination, machine, or process in which TI products or services are used. Information published by TI regarding third-party products or services does not constitute a license from TI to use such products or services or a warranty or endorsement thereof. Use of such information may require a license from a third party under the patents or other intellectual property of the third party, or a license from TI under the patents or other intellectual property of TI.

Reproduction of TI information in TI data books or data sheets is permissible only if reproduction is without alteration and is accompanied by all associated warranties, conditions, limitations, and notices. Reproduction of this information with alteration is an unfair and deceptive business practice. TI is not responsible or liable for such altered documentation. Information of third parties may be subject to additional restrictions.

Resale of TI products or services with statements different from or beyond the parameters stated by TI for that product or service voids all express and any implied warranties for the associated TI product or service and is an unfair and deceptive business practice. TI is not responsible or liable for any such statements.

TI products are not authorized for use in safety-critical applications (such as life support) where a failure of the TI product would reasonably be expected to cause severe personal injury or death, unless officers of the parties have executed an agreement specifically governing such use. Buyers represent that they have all necessary expertise in the safety and regulatory ramifications of their applications, and acknowledge and agree that they are solely responsible for all legal, regulatory and safety-related requirements concerning their products and any use of TI products in such safety-critical applications, notwithstanding any applications-related information or support that may be provided by TI. Further, Buyers must fully indemnify TI and its representatives against any damages arising out of the use of TI products in such safety-critical applications.

TI products are neither designed nor intended for use in military/aerospace applications or environments unless the TI products are specifically designated by TI as military-grade or "enhanced plastic." Only products designated by TI as military-grade meet military specifications. Buyers acknowledge and agree that any such use of TI products which TI has not designated as military-grade is solely at the Buyer's risk, and that they are solely responsible for compliance with all legal and regulatory requirements in connection with such use.

TI products are neither designed nor intended for use in automotive applications or environments unless the specific TI products are designated by TI as compliant with ISO/TS 16949 requirements. Buyers acknowledge and agree that, if they use any non-designated products in automotive applications, TI will not be responsible for any failure to meet such requirements.

Following are URLs where you can obtain information on other Texas Instruments products and application solutions:

### Products

Audio	<a href="http://www.ti.com/audio">www.ti.com/audio</a>
Amplifiers	<a href="http://amplifier.ti.com">amplifier.ti.com</a>
Data Converters	<a href="http://dataconverter.ti.com">dataconverter.ti.com</a>
DLP® Products	<a href="http://www.dlp.com">www.dlp.com</a>
DSP	<a href="http://dsp.ti.com">dsp.ti.com</a>
Clocks and Timers	<a href="http://www.ti.com/clocks">www.ti.com/clocks</a>
Interface	<a href="http://interface.ti.com">interface.ti.com</a>
Logic	<a href="http://logic.ti.com">logic.ti.com</a>
Power Mgmt	<a href="http://power.ti.com">power.ti.com</a>
Microcontrollers	<a href="http://microcontroller.ti.com">microcontroller.ti.com</a>
RFID	<a href="http://www.ti-rfid.com">www.ti-rfid.com</a>
OMAP Mobile Processors	<a href="http://www.ti.com/omap">www.ti.com/omap</a>
Wireless Connectivity	<a href="http://www.ti.com/wirelessconnectivity">www.ti.com/wirelessconnectivity</a>

### Applications

Communications and Telecom	<a href="http://www.ti.com/communications">www.ti.com/communications</a>
Computers and Peripherals	<a href="http://www.ti.com/computers">www.ti.com/computers</a>
Consumer Electronics	<a href="http://www.ti.com/consumer-apps">www.ti.com/consumer-apps</a>
Energy and Lighting	<a href="http://www.ti.com/energy">www.ti.com/energy</a>
Industrial	<a href="http://www.ti.com/industrial">www.ti.com/industrial</a>
Medical	<a href="http://www.ti.com/medical">www.ti.com/medical</a>
Security	<a href="http://www.ti.com/security">www.ti.com/security</a>
Space, Avionics and Defense	<a href="http://www.ti.com/space-avionics-defense">www.ti.com/space-avionics-defense</a>
Transportation and Automotive	<a href="http://www.ti.com/automotive">www.ti.com/automotive</a>
Video and Imaging	<a href="http://www.ti.com/video">www.ti.com/video</a>

TI E2E Community Home Page

[e2e.ti.com](http://e2e.ti.com)

Mailing Address: Texas Instruments, Post Office Box 655303, Dallas, Texas 75265  
Copyright © 2011, Texas Instruments Incorporated