

LM9044 Lambda Sensor Interface Amplifier

 Check for Samples: [LM9044](#)

FEATURES

- Normal Circuit Operation Specified with Inputs up to 3V Below Ground on a Single Supply.
- Gain Factory Trimmed and Specified over Temperature ($\pm 3\%$ of Full-scale from -40°C to $+125^{\circ}\text{C}$)
- Low Power Consumption (Typically 1 mA)
- Fully Protected Inputs
- Input Open Circuit Detection
- Operation Specified over the Entire Automotive Temperature Range (-40°C to $+125^{\circ}\text{C}$)

DESCRIPTION

The LM9044 is a precision differential amplifier specifically designed for operation in the automotive environment. Gain accuracy is specified over the entire automotive temperature range (-40°C to $+125^{\circ}\text{C}$) and is factory trimmed after package assembly. The input circuitry has been specifically designed to reject common-mode signals as much as 3V below ground without the need for a negative voltage supply. This facilitates the use of sensors which are grounded at the engine block while the LM9044 itself is grounded at chassis potential. An external capacitor on the R_F pin sets the maximum operating frequency of the amplifier, thereby filtering high frequency transients. Both inputs are protected against accidental shorting to the battery and against load dump transients. The input impedance is typically 1.2 M Ω .

The output op amp is capable of driving capacitive loads and is fully protected. Also, internal circuitry has been provided to detect open circuit conditions on either or both inputs and force the output to a "home" position (a ratio of the external reference voltage).

Typical Application

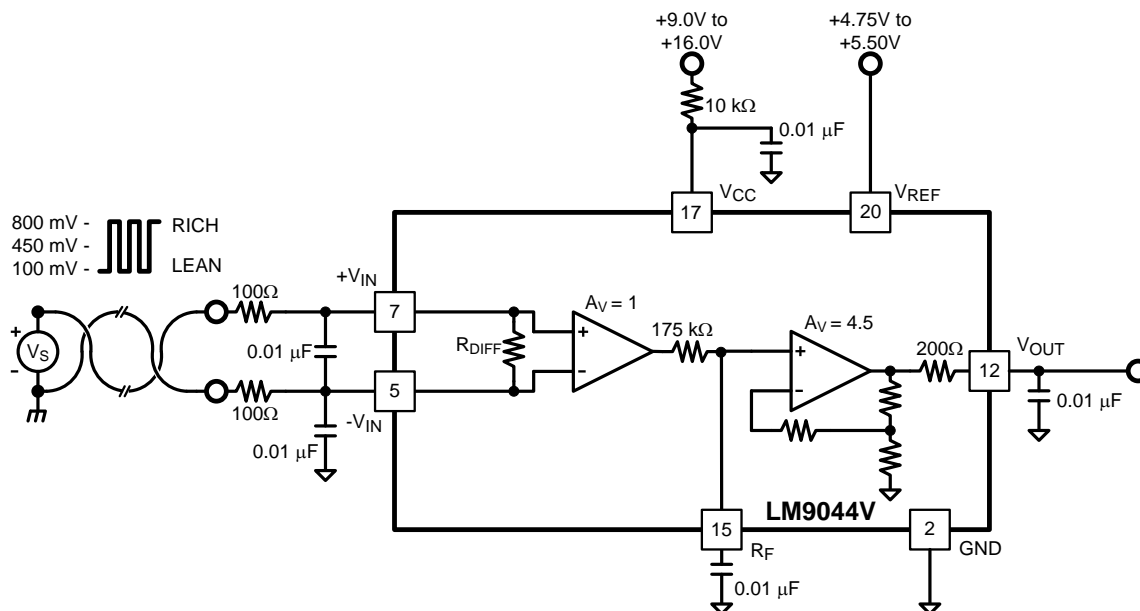

Please be aware that an important notice concerning availability, standard warranty, and use in critical applications of Texas Instruments semiconductor products and disclaimers thereto appears at the end of this data sheet.

All trademarks are the property of their respective owners.

Connection Diagram

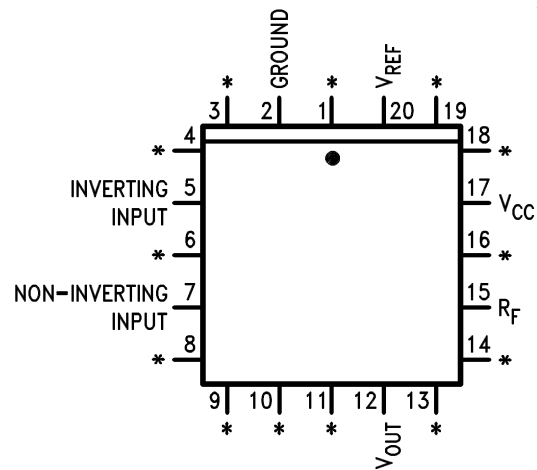

*Pins 1, 3, 4, 6, 8, 9, 10, 11, 13, 14, 16, 18, 19 are trim pins and should be left floating.

**Figure 1. Top View
PLCC Package
See Package Number FN0020A**



These devices have limited built-in ESD protection. The leads should be shorted together or the device placed in conductive foam during storage or handling to prevent electrostatic damage to the MOS gates.

ABSOLUTE MAXIMUM RATINGS⁽¹⁾⁽²⁾

V _{CC} Supply Voltage (R _{VCC} = 15 kΩ)	±60V
V _{REF} Supply Voltage	-0.3V to +6V
DC Input Voltage (Either input) ⁽³⁾	-3V to +16V
Input Transients ⁽⁴⁾	±60V
Power Dissipation see ⁽⁵⁾	1350 mW
Output Short Circuit Duration	Indefinite
Operating Temperature Range	-40°C to +125°C
Storage Temperature Range	-65°C to +150°C
Soldering Information	
PLCC Package	
Vapor Phase (60 seconds)	215°C
Infrared (15 seconds)	220°C

See <http://www.ti.com> for other methods of soldering surface mount devices.

- (1) Absolute Maximum Ratings indicate limits beyond which damage to the device may occur.
- (2) If Military/Aerospace specified devices are required, please contact the Texas Instruments Sales Office/Distributors for availability and specifications.
- (3) With a 100Ω series resistor on each input pin.
- (4) This test is performed with a 1000Ω source impedance.
- (5) For operation in ambient temperatures above 25°C the device must be derated based on a maximum junction temperature of 150°C and a thermal resistance of 93°C/W junction to ambient.

ELECTRICAL CHARACTERISTICS

V_{CC} = 12V, V_{REF} = 5V, -40°C ≤ T_A ≤ 125°C unless otherwise noted

Parameter	Conditions	(1)			(2)			Units
		Min	Typ	Max	Min	Typ	Max	
Differential Voltage Gain	V _{DIFF} = 0.5, -1V ≤ V _{CM} ≤ +1V	4.41	4.50	4.59	-	-	-	V/V
	V _{DIFF} = 0.5, -3V ≤ V _{CM} ≤ +1V	-	-	-	4.36	4.50	4.64	V/V
Gain Error ⁽³⁾	0 ≤ V _{DIFF} ≤ 1V, -1V ≤ V _{CM} ≤ +1V	-2	0	2	-	-	-	%/FS
	0 ≤ V _{DIFF} ≤ 1V, -3 ≤ V _{CM} ≤ +1V	-	-	-	-3	0	3	%/FS
Differential Input Resistance	0 ≤ V _{DIFF} ≤ 1V, -1V ≤ V _{CM} ≤ +1V	0.95	1.20	3.00	-	-	-	MΩ
	0 ≤ V _{DIFF} ≤ 1V, -3 ≤ V _{CM} ≤ +1V	-	-	-	0.70	1.20	4.00	MΩ
Non-Inverting Input Bias Current	0 ≤ V _{DIFF} ≤ 1V, -1 ≤ V _{CM} ≤ +1V	-	±0.38	±0.65	-	-	-	μA
	0 ≤ V _{DIFF} ≤ 1V, -3 ≤ V _{CM} ≤ +1V	-	-	-	-	±0.38	±1.5	μA
Inverting Input Bias Current	0 ≤ V _{DIFF} ≤ 1V, -1 ≤ V _{CM} ≤ +1V	-25	-65	-100	-	-	-	μA
	0 ≤ V _{DIFF} ≤ 1V, -3 ≤ V _{CM} ≤ +1V	-	-	-	-	-45	-150	μA
V _{CC} Supply Current	V _{CC} = 12V, R _{VCC} = 15k	-	300	500	-	-	-	μA
V _{REF} Supply Current	4.75V ≤ V _{REF} ≤ 5.5V	-	0.5	1.0	-	-	-	mA
Common-Mode Voltage Range ⁽⁴⁾		-1	-	1	-3	-	1	V
DC Common-Mode Rejection Ratio	Input Referred							
	-1V ≤ V _{CM} ≤ +1V, V _{DIFF} = 0.5V	50	60	-	-	-	-	dB
Open Circuit Output Voltage	One or Both Inputs Open							
	-1V ≤ V _{CM} ≤ +1V	0.371	0.397	0.423	-	-	-	xV _{REF}
	-3V ≤ V _{CM} ≤ +1V	-	-	-	0.365	0.397	0.439	xV _{REF}
Short Circuit Output Current	Output Grounded	1.0	2.7	5.0	-	-	-	mA

- (1) These parameters are specified and 100% production tested.
- (2) These parameters will be specified but not 100% production tested.
- (3) Gain error is given as a percent of full-scale. Full-scale is defined as 1V at the input and 4.5V at the output.
- (4) The LM9044 has been designed to common-mode to -3V, but production testing is only performed at ±1V.

ELECTRICAL CHARACTERISTICS (continued)
 $V_{CC} = 12V$, $V_{REF} = 5V$, $-40^{\circ}C \leq T_A \leq 125^{\circ}C$ unless otherwise noted

Parameter	Conditions	(1)			(2)			Units
		Min	Typ	Max	Min	Typ	Max	
V_{CC} Power Supply Rejection Ratio	$V_{CC} = 12V$, $R_{V_{CC}} = 15k$ $V_{DIFF} = 0.5V$	50	65	-	-	-	-	dB
V_{REF} Power Supply Rejection Ratio	$V_{REF} = 5 V_{DC}$ $V_{DIFF} = 0.5V$	60	74	-	-	-	-	dB

TYPICAL PERFORMANCE CHARACTERISTICS

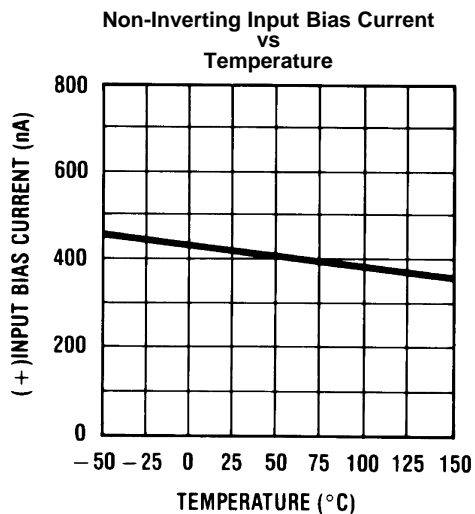

Figure 2.

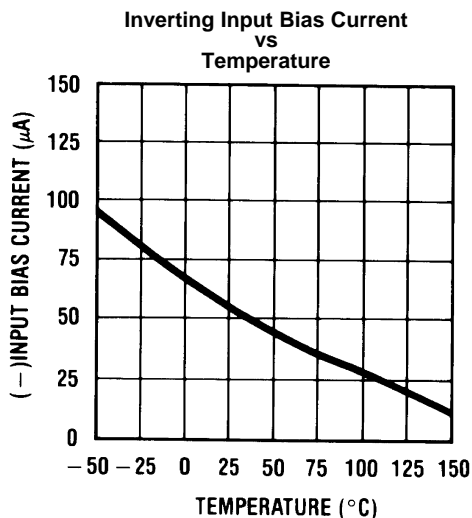

Figure 3.

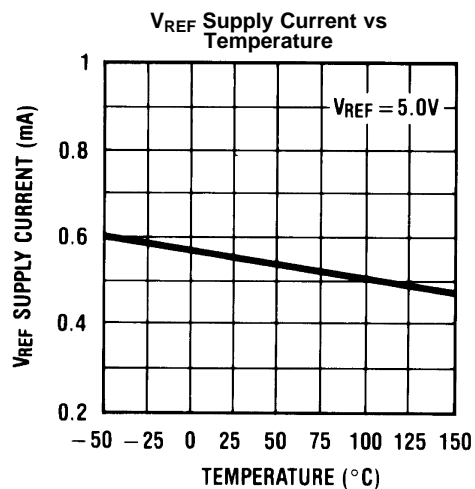

Figure 4.

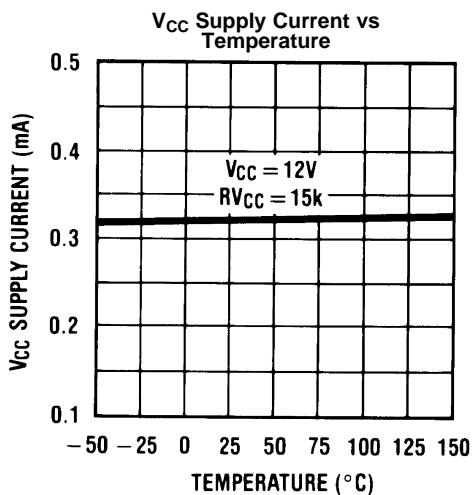

Figure 5.

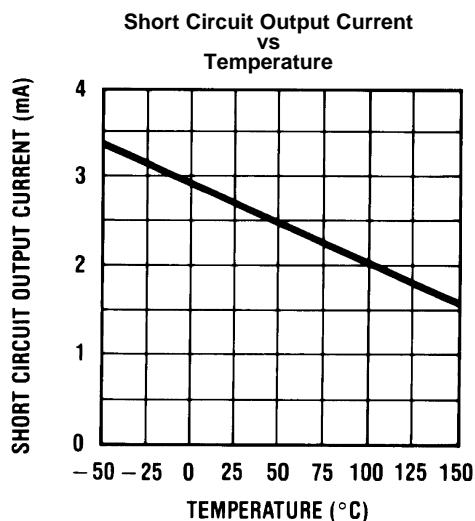

Figure 6.

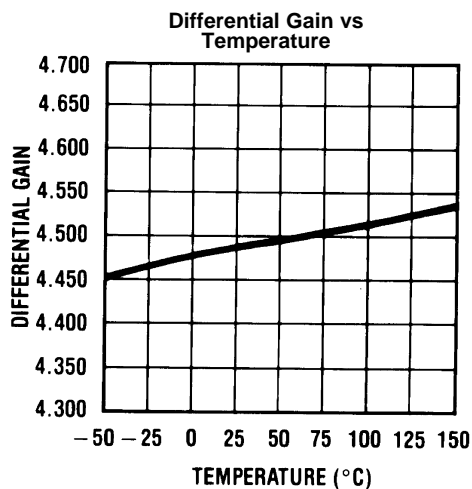

Figure 7.

TYPICAL PERFORMANCE CHARACTERISTICS (continued)

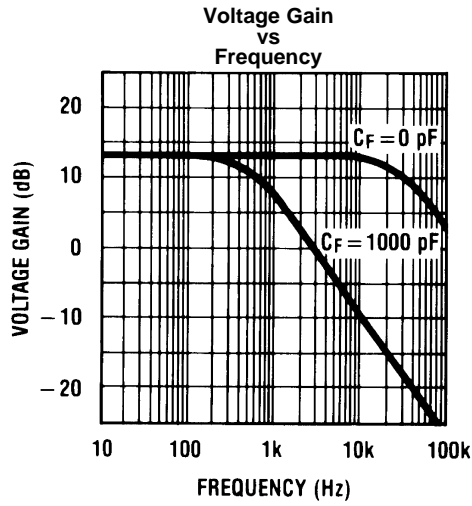

Figure 8.

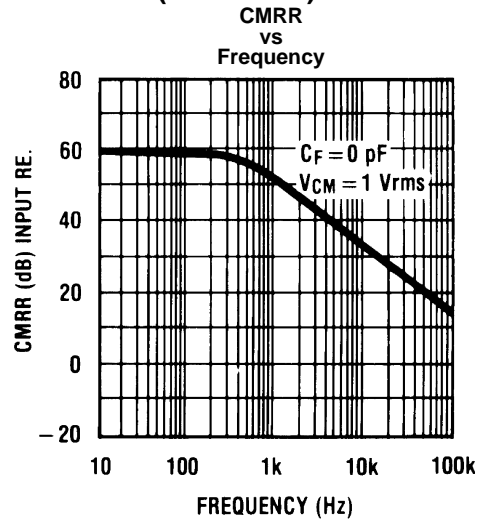

Figure 9.

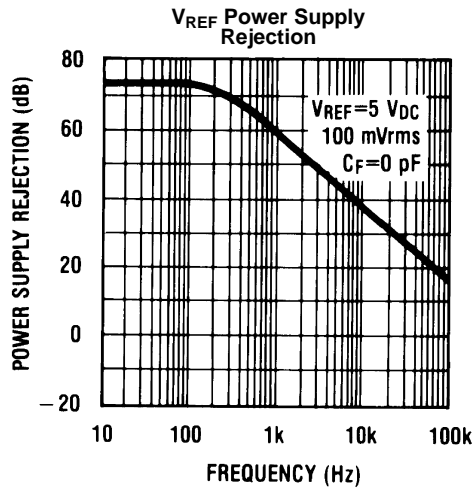

Figure 10.

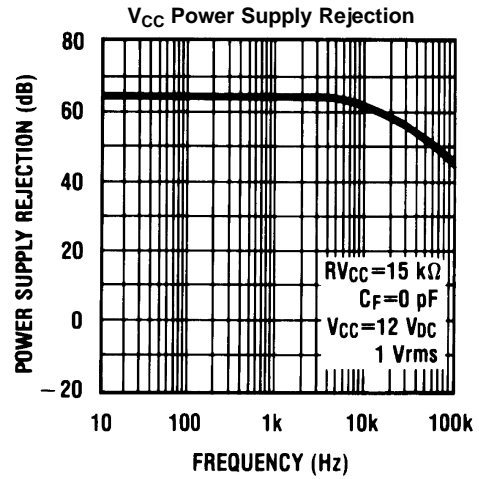
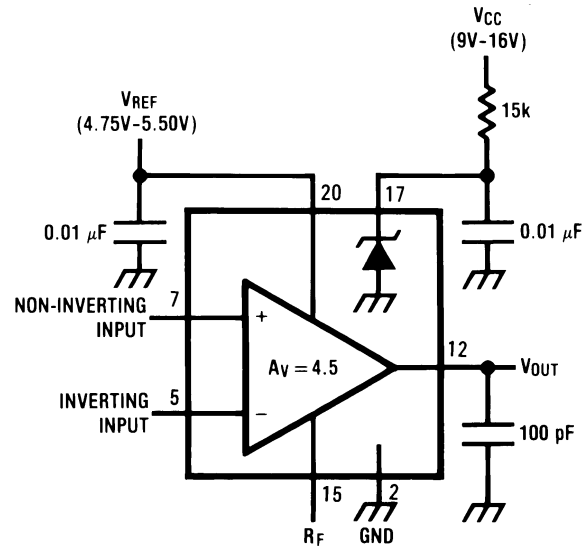
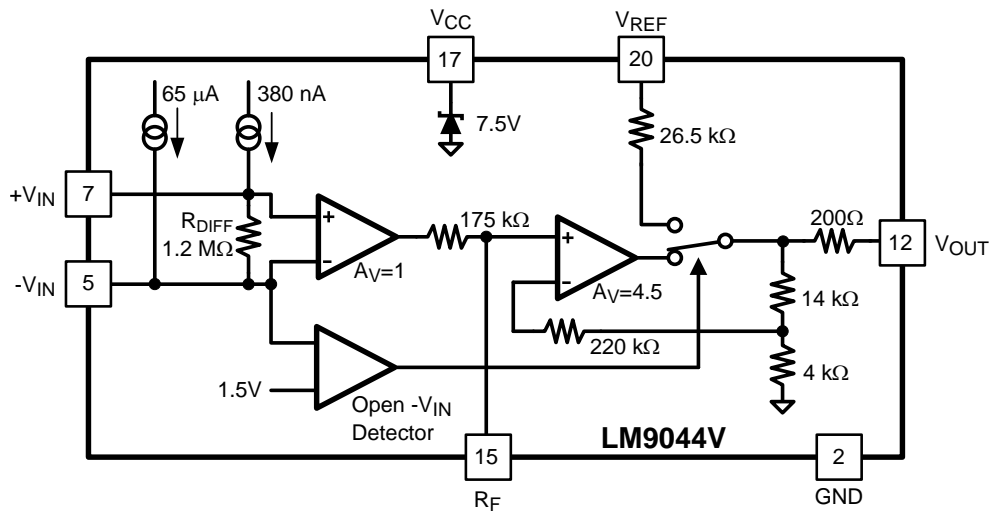

Figure 11.

TEST CIRCUIT



Block Diagram



APPLICATION INFORMATION

CIRCUIT DESCRIPTION

The LM9044 is a single channel device intended to act as a linear interface between a zirconium dioxide oxygen sensor and an A-to-D convertor. The LM9044 is fabricated in Bipolar technology and requires two supplies: a nominal 12V automotive supply (i.e. $V_{BATTERY}$), and a well regulated 5V supply.

The IC consists of a single channel differential input amplifier with a nominal DC gain of 4.5 V/V. The differential inputs have a specified common mode voltage operating range of 1V above and below ground. The circuitry also contains provisions for default output voltage in the cases of cold sensor and open sensor wiring. Additional support circuitry includes one pin for an optional user programmed low pass filter.

COLD SENSOR

Typically, a Lambda sensor will have an impedance of less than 10 k Ω when operating at temperatures between 300°C, and 500°C. When a Lambda sensor is not at operating temperature, its impedance can be more than 10 Meg Ω . Any voltage signal that may be developed is seriously attenuated. During this high impedance condition the LM9044 will provide a default output voltage.

While the Lambda sensor is high impedance the internal non-inverting input bias current (380 nA typical) will flow through the differential input resistance (1.2 M Ω typical) and out the inverting input pin to ground. This will cause a voltage to be developed across the differential inputs:

$$V_{IN(DIFF)} = 380 \text{ nA} \times 1.2 \text{ M}\Omega$$

$$V_{IN(DIFF)} = 456 \text{ mV}$$

The 456 mV across differential input resistance will be the dominant input signal, and the typical V_{OUT} will be:

$$V_{OUT} = V_{IN(DIFF)} \times 4.50$$

$$V_{OUT} = 456 \text{ mV} \times 4.50$$

$$V_{OUT} = 2.0\text{V}$$

As the Lambda sensor is heated, and the sensor impedance begins to drop, the voltage signal from the sensor will become the dominate signal.

The non-inverting input bias current is scaled to the V_{REF} voltage. As the V_{REF} voltage increases, or decreases, this bias current will change proportionally.

OPEN INPUT PINS DEFAULTS

In any remote sensor application it is desirable to be able to deal with the possibility of open connections between the sensor and the control module. The LM9044 is capable of providing a default output voltage should either, or both, of the wires to the Lambda sensor open. The two inputs handle the open circuit condition differently.

For the case of an open connection at the non-inverting input, the device would react exactly the same as for the Cold Sensor condition. The internal non-inverting input bias current (380 nA typical) flowing through the differential input resistance (1.2 M Ω typical) would cause the typical output voltage to be at a value defined by:

$$V_{OUT} = ((380 \text{ nA} \times 1.2\text{M}\Omega) \times 4.50)$$

$$V_{OUT} = 2.0\text{V}$$

The inverting input would still be connected to the Lambda sensor ground, so common mode signals would still need to be considered in this condition.

For the case of an open connection of the inverting input, the device output stage switches from the amplifier output to a resistive voltage divider. The LM9044 has a comparator to monitor the voltage on the inverting input pin, and a 65 μA (typical) current source that will force the pin high if the pin is open. When the voltage on the inverting pin goes above typically 1.5V, the comparator will switch the output pin from the amplifier output to the resistive voltage divider stage. In this case, the default V_{OUT} is not dependent on the gain stage, and any signal on the non-inverting input will be ignored.

In this condition V_{OUT} is:

$$V_{OUT} = V_{REF} \times ((14k + 4k) / (26.5k + 14k + 4k))$$

$$V_{OUT} = V_{REF} \times 0.4045$$

When V_{REF} is at 5.0V, V_{OUT} is defined as:

$$V_{OUT} = 5.0V \times 0.4045$$

$$V_{OUT} = 2.0V$$

In the cases where both the inverting and non-inverting pins are open, the open inverting pin condition (i.e.: a voltage divider across the output) will be the dominant condition.

Any common mode voltage transient on the inverting input pin which goes above the comparator threshold will immediately cause the output to switch to the resistive voltage divider mode. The output will return to normal operation when the voltage on the inverting input falls below the 1.5V threshold.

OUTPUT RESISTANCE

Under normal operating conditions the output pin resistance is typically 200Ω.

If the LM9044 is operating in a default output mode due an open connection on the inverting input, the output resistance will typically appear to be close to 11 kΩ.

An external output filter capacitor value of no more than 0.01 μF is generally recommended. Since the output pin voltage drive is basically a simple NPN emitter follower, the output pin pull-down is done by the internal feedback resistor string. With larger value capacitors on the output pin the effect will be somewhat similar to a voltage peak detector where the output capacitor is charged through the 200Ω resistor, and discharged back through the 200Ω resistor and the 18 kΩ feedback resistor string to ground.

The output resistance provides current limiting for the output stage should it become shorted to Ground. Any DC loading of the output will cause an error in the output voltage.

SUPPLY BYPASSING

For best performance the LM9044 requires a V_{REF} supply which is stable and noise free. The same 5V reference supply used for the A/D converter is the recommended LM9044 V_{REF} supply.

The LM9044 V_{CC} pin has an internal zener shunt voltage regulator, typically 7.5V, and requires a series resistor to limit the current. The V_{CC} pin should be bypassed with a minimum 0.01 μF capacitor to the Ground pin, and should be located as close to the device as possible. Some applications may require an additional bypass capacitance if the system voltage is unusually noisy.

SETTING THE BANDWIDTH

The LM9044 bandwidth is limited by an external capacitor (C_F) on the R_F pin.

This pin has an internal 175 kΩ resistor. The external capacitor and the internal resistor form a simple RC low-pass filter with a corner frequency (f_C) defined as:

$$f_C = 1 / (2 \times \pi \times 175 \text{ k}\Omega \times C_F)$$

With a C_F capacitor value of 0.001 μF, the corner frequency is:

$$f_C = 1 / (2 \times \pi \times 175 \text{ k}\Omega \times 0.001 \text{ }\mu\text{F})$$

$$f_C = 909 \text{ Hz}$$

INPUT FILTERING

Filtering at the differential inputs is strongly recommended. Both the differential voltage signal and the common mode voltage signal should have low pass filters.

Input filtering is accomplished with series resistors on the input pins, and appropriate bypass capacitors. Typical input pin series resistance values are in the 100Ω to 1kΩ range. Series resistance values larger than 1kΩ will generate offset voltages that affect the accuracy of the signal voltage seen at the differential input pins.

Simplified Internal Schematic

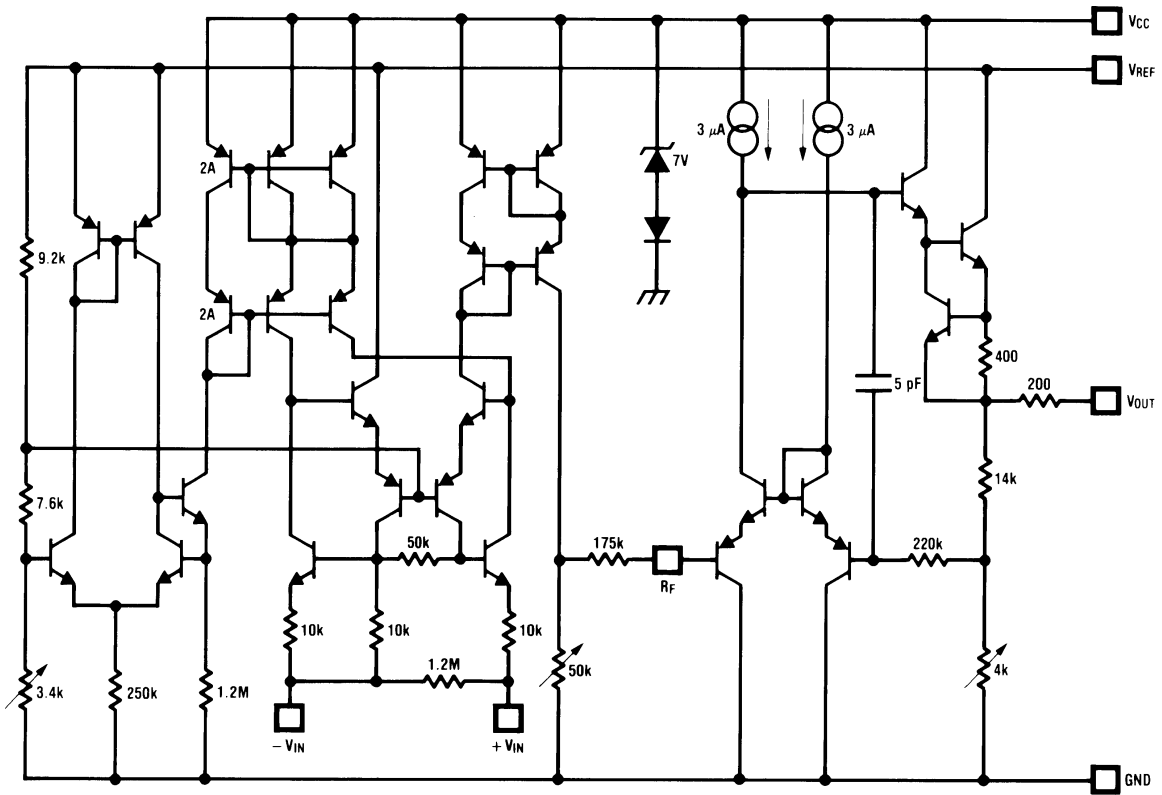

REVISION HISTORY

Changes from Revision C (March 2013) to Revision D	Page
<hr/> <ul style="list-style-type: none">• Changed layout of National Data Sheet to TI format	<hr/> 10

PACKAGING INFORMATION

Orderable Device	Status (1)	Package Type	Package Drawing	Pins	Package Qty	Eco Plan (2)	Lead/Ball Finish	MSL Peak Temp (3)	Op Temp (°C)	Top-Side Markings (4)	Samples
LM9044V	ACTIVE	PLCC	FN	20	40	TBD	Call TI	Call TI	-40 to 125	LM9044V	Samples
LM9044V/NOPB	ACTIVE	PLCC	FN	20	40	Green (RoHS & no Sb/Br)	SN	Level-2A-250C-4 WEEK	-40 to 125	LM9044V	Samples
LM9044VX	ACTIVE	PLCC	FN	20	1000	TBD	Call TI	Call TI	-40 to 125	LM9044V	Samples
LM9044VX/NOPB	ACTIVE	PLCC	FN	20	1000	Green (RoHS & no Sb/Br)	SN	Level-2A-250C-4 WEEK	-40 to 125	LM9044V	Samples

(1) The marketing status values are defined as follows:

ACTIVE: Product device recommended for new designs.

LIFEBUY: TI has announced that the device will be discontinued, and a lifetime-buy period is in effect.

NRND: Not recommended for new designs. Device is in production to support existing customers, but TI does not recommend using this part in a new design.

PREVIEW: Device has been announced but is not in production. Samples may or may not be available.

OBSOLETE: TI has discontinued the production of the device.

(2) Eco Plan - The planned eco-friendly classification: Pb-Free (RoHS), Pb-Free (RoHS Exempt), or Green (RoHS & no Sb/Br) - please check <http://www.ti.com/productcontent> for the latest availability information and additional product content details.

TBD: The Pb-Free/Green conversion plan has not been defined.

Pb-Free (RoHS): TI's terms "Lead-Free" or "Pb-Free" mean semiconductor products that are compatible with the current RoHS requirements for all 6 substances, including the requirement that lead not exceed 0.1% by weight in homogeneous materials. Where designed to be soldered at high temperatures, TI Pb-Free products are suitable for use in specified lead-free processes.

Pb-Free (RoHS Exempt): This component has a RoHS exemption for either 1) lead-based flip-chip solder bumps used between the die and package, or 2) lead-based die adhesive used between the die and leadframe. The component is otherwise considered Pb-Free (RoHS compatible) as defined above.

Green (RoHS & no Sb/Br): TI defines "Green" to mean Pb-Free (RoHS compatible), and free of Bromine (Br) and Antimony (Sb) based flame retardants (Br or Sb do not exceed 0.1% by weight in homogeneous material)

(3) MSL, Peak Temp. -- The Moisture Sensitivity Level rating according to the JEDEC industry standard classifications, and peak solder temperature.

(4) Multiple Top-Side Markings will be inside parentheses. Only one Top-Side Marking contained in parentheses and separated by a "~" will appear on a device. If a line is indented then it is a continuation of the previous line and the two combined represent the entire Top-Side Marking for that device.

Important Information and Disclaimer: The information provided on this page represents TI's knowledge and belief as of the date that it is provided. TI bases its knowledge and belief on information provided by third parties, and makes no representation or warranty as to the accuracy of such information. Efforts are underway to better integrate information from third parties. TI has taken and continues to take reasonable steps to provide representative and accurate information but may not have conducted destructive testing or chemical analysis on incoming materials and chemicals. TI and TI suppliers consider certain information to be proprietary, and thus CAS numbers and other limited information may not be available for release.

In no event shall TI's liability arising out of such information exceed the total purchase price of the TI part(s) at issue in this document sold by TI to Customer on an annual basis.

FN (S-PQCC-J**)

PLASTIC J-LEADED CHIP CARRIER

20 PIN SHOWN

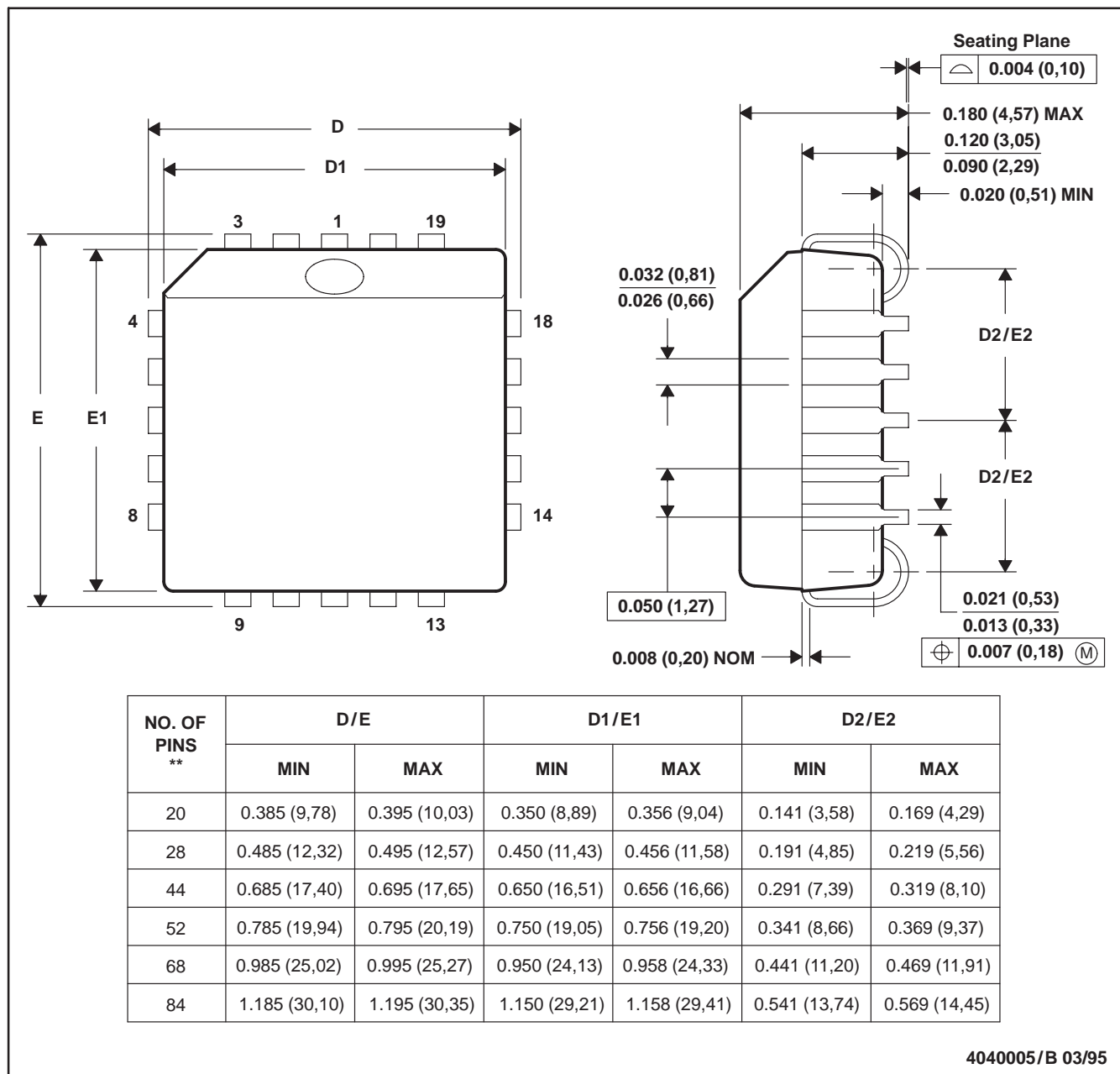

- NOTES: A. All linear dimensions are in inches (millimeters).
 B. This drawing is subject to change without notice.
 C. Falls within JEDEC MS-018

IMPORTANT NOTICE

Texas Instruments Incorporated and its subsidiaries (TI) reserve the right to make corrections, enhancements, improvements and other changes to its semiconductor products and services per JESD46, latest issue, and to discontinue any product or service per JESD48, latest issue. Buyers should obtain the latest relevant information before placing orders and should verify that such information is current and complete. All semiconductor products (also referred to herein as "components") are sold subject to TI's terms and conditions of sale supplied at the time of order acknowledgment.

TI warrants performance of its components to the specifications applicable at the time of sale, in accordance with the warranty in TI's terms and conditions of sale of semiconductor products. Testing and other quality control techniques are used to the extent TI deems necessary to support this warranty. Except where mandated by applicable law, testing of all parameters of each component is not necessarily performed.

TI assumes no liability for applications assistance or the design of Buyers' products. Buyers are responsible for their products and applications using TI components. To minimize the risks associated with Buyers' products and applications, Buyers should provide adequate design and operating safeguards.

TI does not warrant or represent that any license, either express or implied, is granted under any patent right, copyright, mask work right, or other intellectual property right relating to any combination, machine, or process in which TI components or services are used. Information published by TI regarding third-party products or services does not constitute a license to use such products or services or a warranty or endorsement thereof. Use of such information may require a license from a third party under the patents or other intellectual property of the third party, or a license from TI under the patents or other intellectual property of TI.

Reproduction of significant portions of TI information in TI data books or data sheets is permissible only if reproduction is without alteration and is accompanied by all associated warranties, conditions, limitations, and notices. TI is not responsible or liable for such altered documentation. Information of third parties may be subject to additional restrictions.

Resale of TI components or services with statements different from or beyond the parameters stated by TI for that component or service voids all express and any implied warranties for the associated TI component or service and is an unfair and deceptive business practice. TI is not responsible or liable for any such statements.

Buyer acknowledges and agrees that it is solely responsible for compliance with all legal, regulatory and safety-related requirements concerning its products, and any use of TI components in its applications, notwithstanding any applications-related information or support that may be provided by TI. Buyer represents and agrees that it has all the necessary expertise to create and implement safeguards which anticipate dangerous consequences of failures, monitor failures and their consequences, lessen the likelihood of failures that might cause harm and take appropriate remedial actions. Buyer will fully indemnify TI and its representatives against any damages arising out of the use of any TI components in safety-critical applications.

In some cases, TI components may be promoted specifically to facilitate safety-related applications. With such components, TI's goal is to help enable customers to design and create their own end-product solutions that meet applicable functional safety standards and requirements. Nonetheless, such components are subject to these terms.

No TI components are authorized for use in FDA Class III (or similar life-critical medical equipment) unless authorized officers of the parties have executed a special agreement specifically governing such use.

Only those TI components which TI has specifically designated as military grade or "enhanced plastic" are designed and intended for use in military/aerospace applications or environments. Buyer acknowledges and agrees that any military or aerospace use of TI components which have **not** been so designated is solely at the Buyer's risk, and that Buyer is solely responsible for compliance with all legal and regulatory requirements in connection with such use.

TI has specifically designated certain components as meeting ISO/TS16949 requirements, mainly for automotive use. In any case of use of non-designated products, TI will not be responsible for any failure to meet ISO/TS16949.

Products

Audio	www.ti.com/audio
Amplifiers	amplifier.ti.com
Data Converters	dataconverter.ti.com
DLP® Products	www.dlp.com
DSP	dsp.ti.com
Clocks and Timers	www.ti.com/clocks
Interface	interface.ti.com
Logic	logic.ti.com
Power Mgmt	power.ti.com
Microcontrollers	microcontroller.ti.com
RFID	www.ti-rfid.com
OMAP Applications Processors	www.ti.com/omap
Wireless Connectivity	www.ti.com/wirelessconnectivity

Applications

Automotive and Transportation	www.ti.com/automotive
Communications and Telecom	www.ti.com/communications
Computers and Peripherals	www.ti.com/computers
Consumer Electronics	www.ti.com/consumer-apps
Energy and Lighting	www.ti.com/energy
Industrial	www.ti.com/industrial
Medical	www.ti.com/medical
Security	www.ti.com/security
Space, Avionics and Defense	www.ti.com/space-avionics-defense
Video and Imaging	www.ti.com/video

TI E2E Community

e2e.ti.com