



# Precision LOGARITHMIC AND LOG RATIO AMPLIFIERS

## FEATURES

- EASY-TO-USE COMPLETE FUNCTION
- OUTPUT SCALING AMPLIFIER
- ON-CHIP 2.5V VOLTAGE REFERENCE
- HIGH ACCURACY: 0.2% FSO Over 5 Decades
- WIDE INPUT DYNAMIC RANGE:  
7.5 Decades, 100pA to 3.5mA
- LOW QUIESCENT CURRENT: 1.75mA
- WIDE SUPPLY RANGE:  $\pm 4.5V$  to  $\pm 18V$
- PACKAGES: SO-14 (narrow) and SO-16

## DESCRIPTION

The LOG112 and LOG2112 are versatile integrated circuits that compute the logarithm or log ratio of an input current relative to a reference current.  $V_{\text{LOGOUT}}$  of the LOG112 and LOG2112 are trimmed to 0.5V per decade of input current, ensuring high precision over a wide dynamic range of input signals.

The LOG112 and LOG2112 features a 2.5V voltage reference that may be used to generate a precision current reference using an external resistor.

Low DC offset voltage and temperature drift allow accurate measurement of low-level signals over the specified temperature range of  $-5^{\circ}\text{C}$  to  $+75^{\circ}\text{C}$ .

## APPLICATIONS

- LOG, LOG RATIO:  
Communication, Analytical, Medical, Industrial,  
Test, General Instrumentation
- PHOTODIODE SIGNAL COMPRESSION AMP
- ANALOG SIGNAL COMPRESSION IN FRONT  
OF ANALOG-TO-DIGITAL (A/D) CONVERTER
- ABSORBANCE MEASUREMENT
- OPTICAL DENSITY MEASUREMENT

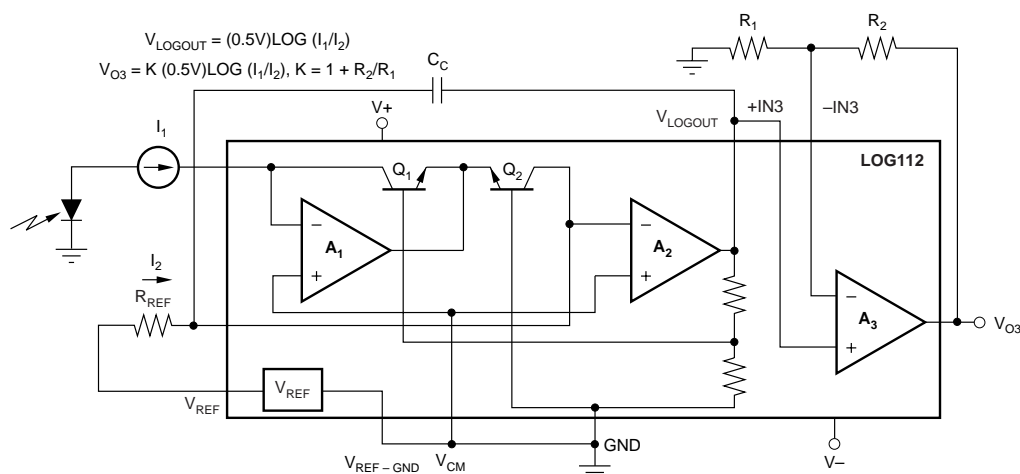

NOTE: Internal resistors are used to compensate gain change over temperature. The  $V_{\text{CM}}$  pin is internally connected to GND in the LOG2112.



Please be aware that an important notice concerning availability, standard warranty, and use in critical applications of Texas Instruments semiconductor products and disclaimers thereto appears at the end of this data sheet.

All trademarks are the property of their respective owners.

PRODUCTION DATA information is current as of publication date. Products conform to specifications per the terms of Texas Instruments standard warranty. Production processing does not necessarily include testing of all parameters.



Copyright © 2002-2005, Texas Instruments Incorporated

## ABSOLUTE MAXIMUM RATINGS<sup>(1)</sup>

Supply Voltage, V+ to V- .....	±18V
Inputs .....	±18V
Input Current .....	±10mA
Output Short-Circuit Current <sup>(2)</sup> .....	Continuous
Operating Temperature .....	-40°C to +85°C
Storage Temperature .....	-55°C to +125°C
Junction Temperature .....	+150°C
Lead Temperature (soldering, 10s) .....	+300°C

NOTES: (1) Stresses above these ratings may cause permanent damage. Exposure to absolute maximum conditions for extended periods may degrade device reliability. (2) One output per package.



## ELECTROSTATIC DISCHARGE SENSITIVITY

This integrated circuit can be damaged by ESD. Texas Instruments recommends that all integrated circuits be handled with appropriate precautions. Failure to observe proper handling and installation procedures can cause damage.

ESD damage can range from subtle performance degradation to complete device failure. Precision integrated circuits may be more susceptible to damage because very small parametric changes could cause the device not to meet its published specifications.

## PACKAGE/ORDERING INFORMATION<sup>(1)</sup>

PRODUCT	PACKAGE-LEAD	PACKAGE DESIGNATOR	PACKAGE MARKING
LOG112	SO-14	D	LOG112A
LOG2112	SO-16	DW	LOG2112A

NOTES: (1) For the most current package and ordering information, see the Package Option Addendum at the end of this document, or see the TI website at [www.ti.com](http://www.ti.com).

## PIN CONFIGURATION

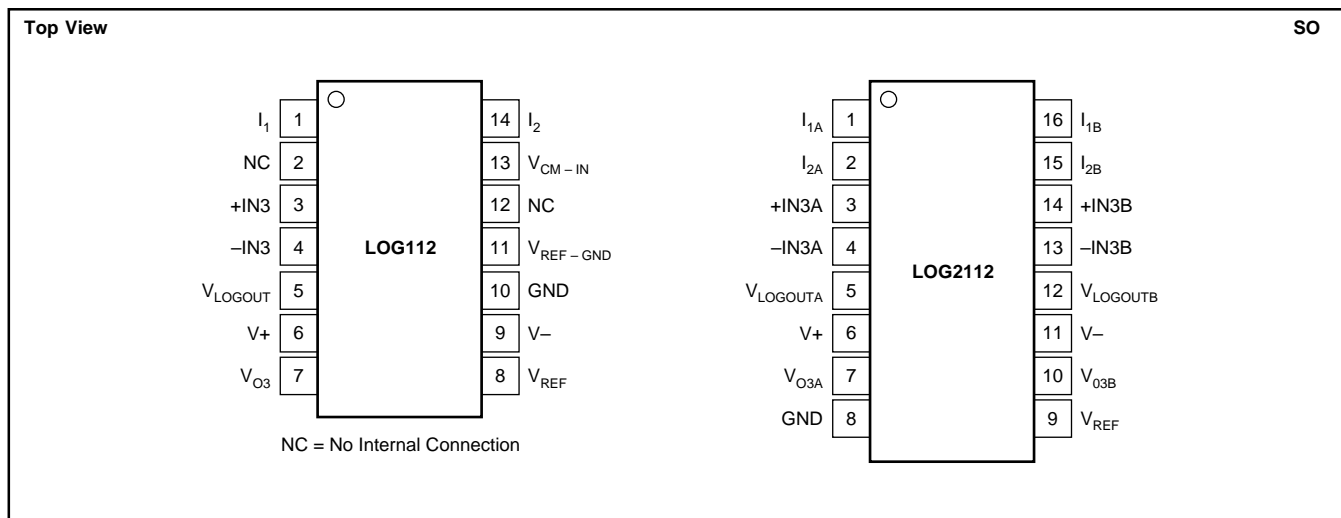

# ELECTRICAL CHARACTERISTICS

**Boldface** limits apply over the specified temperature range,  $T_A = -5^{\circ}\text{C}$  to  $+75^{\circ}\text{C}$ .

At  $T_A = +25^{\circ}\text{C}$ ,  $V_S = \pm 5\text{V}$ , and  $R_{OUT} = 10\text{k}\Omega$ , unless otherwise noted.

PARAMETER	CONDITION	LOG112, LOG2112			UNITS
		MIN	TYP	MAX	
<b>CORE LOG FUNCTION</b> $V_{IN}/V_{OUT}$ Equation		$V_{LOGOUT} = (0.5V)\text{LOG}(I_1/I_2)$			V
<b>LOG CONFORMITY ERROR<sup>(1)</sup></b> Initial	1nA to 100 $\mu$ A (5 decades) 100pA to 3.5mA (7.5 decades)		0.01 0.13	0.2	% %
<b>over Temperature</b>	<b>1nA to 100<math>\mu</math>A (5 decades)</b> <b>100pA to 3.5mA (7.5 decades)</b>		0.0001 0.005		<b>%/<math>^{\circ}\text{C}</math></b> <b>%/<math>^{\circ}\text{C}</math></b>
<b>GAIN<sup>(2)</sup></b> Initial Value	1nA to 100 $\mu$ A		0.5		V/decade
Gain Error	1nA to 100 $\mu$ A		0.10	$\pm 1$	%
<b>vs Temperature</b>	<b><math>T_{MIN}</math> to <math>T_{MAX}</math></b>		<b>0.003</b>	<b>0.01</b>	<b>%/<math>^{\circ}\text{C}</math></b>
<b>INPUT, <math>A_{1A}</math> and <math>A_{1B}</math>, <math>A_{2A}</math>, <math>A_{2B}</math></b> Offset Voltage	$T_{MIN}$ to $T_{MAX}$ $V_S = \pm 4.5\text{V}$ to $\pm 18\text{V}$		$\pm 0.3$	$\pm 1.5$	mV
<b>vs Temperature</b>			$\pm 2$		$\mu\text{V}/^{\circ}\text{C}$
vs Power Supply (PSRR)			5	20	$\mu\text{V}/\text{V}$
Input Bias Current			$\pm 5$		pA
<b>vs Temperature</b>			<b>Doubles Every <math>10^{\circ}\text{C}</math></b>		
Voltage Noise	$T_{MIN}$ to $T_{MAX}$ $f = 10\text{Hz}$ to $10\text{kHz}$		3		$\mu\text{Vrms}$
Current Noise	$f = 1\text{kHz}$		30		nV/ $\sqrt{\text{Hz}}$
Common-Mode Voltage Range (Positive)	$f = 1\text{kHz}$	(V+) - 2	(V+) - 1.5		V
(Negative)		(V-) + 2	(V-) + 1.2		V
Common-Mode Rejection Ratio (CMRR)			10		$\mu\text{V}/\text{V}$
<b>OUTPUT, (<math>V_{LOG OUT}</math>) <math>A_{2A}</math>, <math>A_{2B}</math></b> Output Offset, $V_{OSO}$ , Initial	$T_{MIN}$ to $T_{MAX}$ $V_S = \pm 5\text{V}$	(V-) + 1.2	$\pm 3$	$\pm 15$	mV
<b>vs Temperature</b>			$\pm 10$		$\mu\text{V}/^{\circ}\text{C}$
Full-Scale Output (FSO)				(V+) - 1.5	V
Short-Circuit Current			$\pm 18$		mA
<b>TOTAL ERROR<sup>(3)(4)</sup></b> Initial	$I_1$ or $I_2$ remains fixed while other varies. Min to Max $I_1$ or $I_2 = 5\text{mA}$ ( $V_S \geq \pm 6\text{V}$ )			$\pm 150$	mV
	$I_1$ or $I_2 = 3.5\text{mA}$			$\pm 75$	mV
	$I_1$ or $I_2 = 1\text{mA}$			$\pm 20$	mV
	$I_1$ or $I_2 = 100\mu\text{A}$			$\pm 20$	mV
	$I_1$ or $I_2 = 10\mu\text{A}$			$\pm 20$	mV
	$I_1$ or $I_2 = 1\mu\text{A}$			$\pm 20$	mV
	$I_1$ or $I_2 = 100\text{nA}$			$\pm 20$	mV
	$I_1$ or $I_2 = 10\text{nA}$			$\pm 20$	mV
	$I_1$ or $I_2 = 1\text{nA}$			$\pm 20$	mV
	$I_1$ or $I_2 = 350\text{pA}$			$\pm 20$	mV
	$I_1$ or $I_2 = 100\text{pA}$			$\pm 20$	mV
<b>vs Temperature</b>	<b><math>I_1</math> or <math>I_2 = 3.5\text{mA}</math></b>		$\pm 1.2$		<b>mV/<math>^{\circ}\text{C}</math></b>
	<b><math>I_1</math> or <math>I_2 = 1\text{mA}</math></b>		$\pm 0.4$		<b>mV/<math>^{\circ}\text{C}</math></b>
	<b><math>I_1</math> or <math>I_2 = 100\mu\text{A}</math></b>		$\pm 0.1$		<b>mV/<math>^{\circ}\text{C}</math></b>
	<b><math>I_1</math> or <math>I_2 = 10\mu\text{A}</math></b>		$\pm 0.05$		<b>mV/<math>^{\circ}\text{C}</math></b>
	<b><math>I_1</math> or <math>I_2 = 1\mu\text{A}</math></b>		$\pm 0.05$		<b>mV/<math>^{\circ}\text{C}</math></b>
	<b><math>I_1</math> or <math>I_2 = 100\text{nA}</math></b>		$\pm 0.09$		<b>mV/<math>^{\circ}\text{C}</math></b>
	<b><math>I_1</math> or <math>I_2 = 10\text{nA}</math></b>		$\pm 0.2$		<b>mV/<math>^{\circ}\text{C}</math></b>
	<b><math>I_1</math> or <math>I_2 = 1\text{nA}</math></b>		$\pm 0.3$		<b>mV/<math>^{\circ}\text{C}</math></b>
	<b><math>I_1</math> or <math>I_2 = 350\text{pA}</math></b>		$\pm 0.1$		<b>mV/<math>^{\circ}\text{C}</math></b>
	<b><math>I_1</math> or <math>I_2 = 100\text{pA}</math></b>		$\pm 0.3$		<b>mV/<math>^{\circ}\text{C}</math></b>
<b>vs Supply</b>	$I_1$ or $I_2 = 3.5\text{mA}$		$\pm 3.0$		mV/V
	$I_1$ or $I_2 = 1\text{mA}$		$\pm 0.1$		mV/V
	$I_1$ or $I_2 = 100\mu\text{A}$		$\pm 0.1$		mV/V
	$I_1$ or $I_2 = 10\mu\text{A}$		$\pm 0.1$		mV/V
	$I_1$ or $I_2 = 1\mu\text{A}$		$\pm 0.1$		mV/V
	$I_1$ or $I_2 = 100\text{nA}$		$\pm 0.1$		mV/V
	$I_1$ or $I_2 = 10\text{nA}$		$\pm 0.1$		mV/V
	$I_1$ or $I_2 = 1\text{nA}$		$\pm 0.25$		mV/V
	$I_1$ or $I_2 = 350\text{pA}$		$\pm 0.1$		mV/V
	$I_1$ or $I_2 = 100\text{pA}$		$\pm 0.1$		mV/V

NOTES: (1) Log Conformity Error is the peak deviation from the best-fit-straight line of  $V_O$  versus  $\text{LOG}(I_1/I_2)$  curve expressed as a percent of peak-to-peak full-scale output. K, scale factor, equals 0.5V output per decade of input current. (2) Scale factor of core log function is trimmed to 0.5V output per decade change of input current. (3) Worst-case Total Error for any ratio of  $I_1/I_2$ , as the largest of the two errors, when  $I_1$  and  $I_2$  are considered separately. (4) Total Error includes offset voltage, bias current, gain, and log conformity. (5) Bandwidth (3dB) and transient response are a function of both the compensation capacitor and the level of input current.



# TYPICAL CHARACTERISTICS

At  $T_A = +25^\circ\text{C}$ ,  $V_S = \pm 5\text{V}$ , and  $R_L = 10\text{k}\Omega$ , unless otherwise noted.

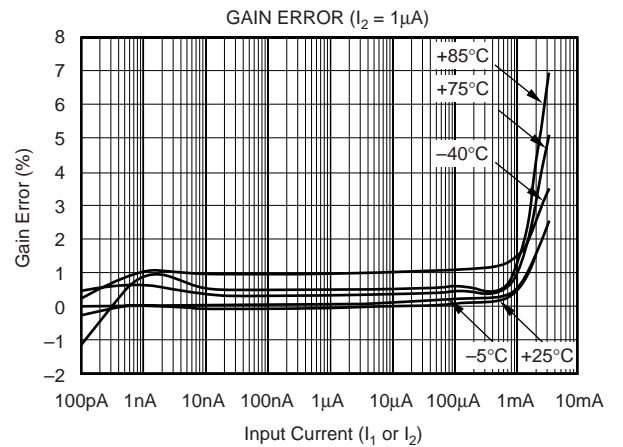
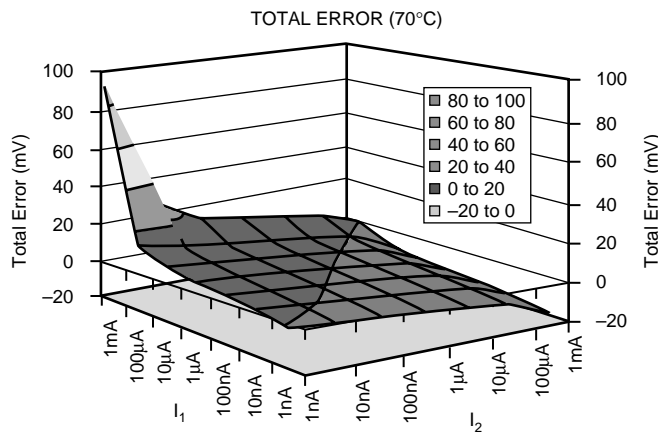
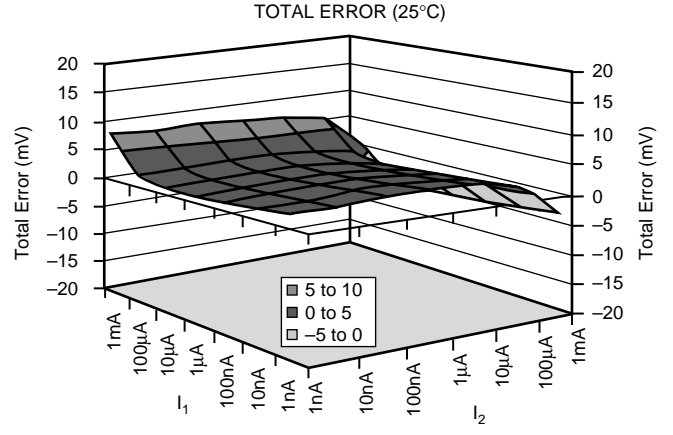
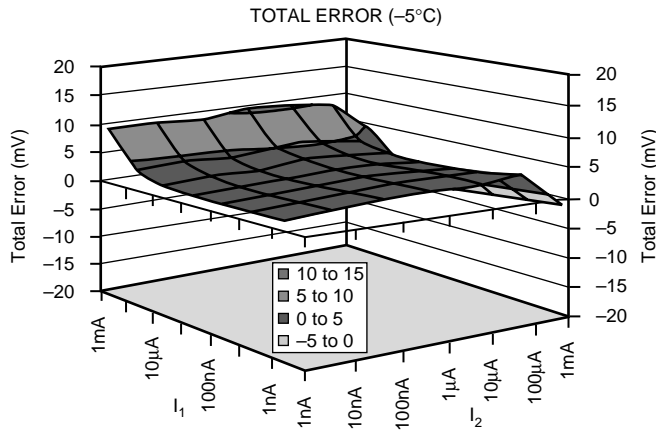
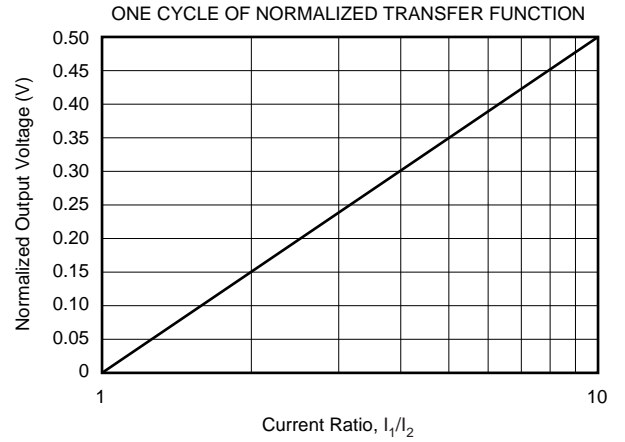
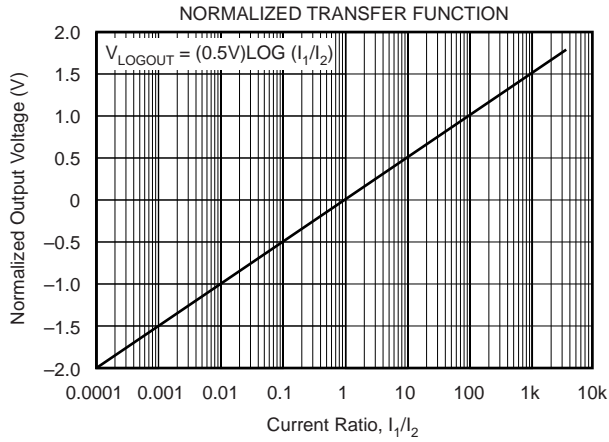

# TYPICAL CHARACTERISTICS (Cont.)

At  $T_A = +25^\circ\text{C}$ ,  $V_S = \pm 5\text{V}$ , and  $R_L = 10\text{k}\Omega$ , unless otherwise noted.

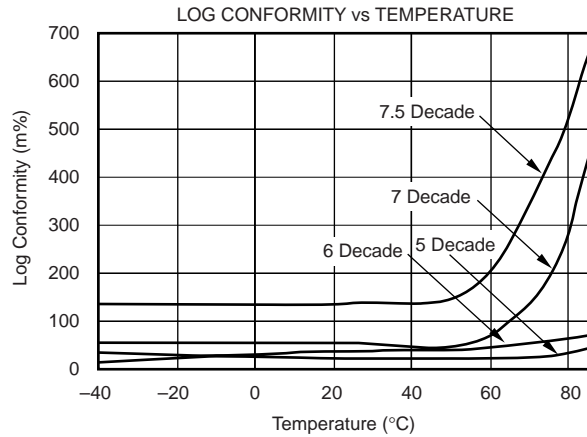
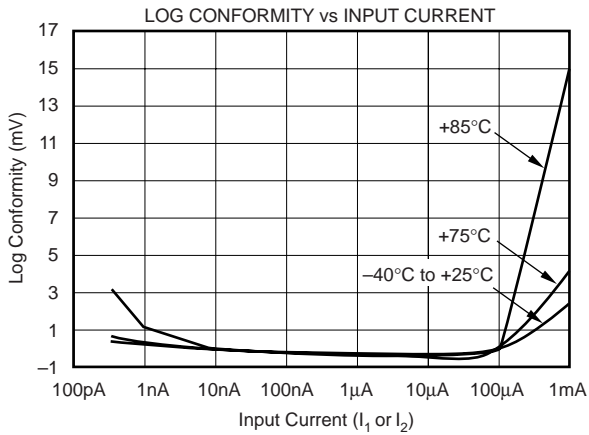
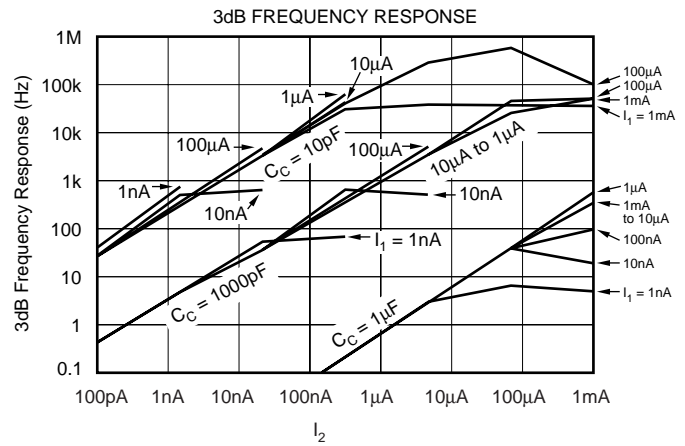
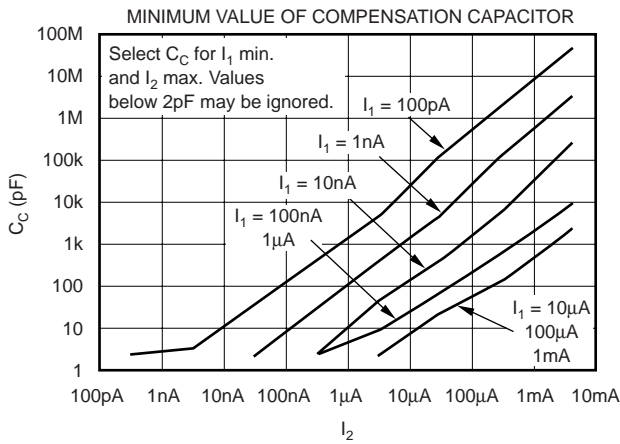

# APPLICATION INFORMATION

The LOG112 is a true logarithmic amplifier that uses the base-emitter voltage relationship of bipolar transistors to compute the logarithm, or logarithmic ratio of a current ratio.

Figure 1 and Figure 2 show the basic connections required for operation of the LOG112 and LOG2112. In order to reduce the influence of lead inductance of power-supply lines, it is recommended that each supply be bypassed with a 10µF tantalum capacitor in parallel with a 1000pF ceramic capacitor, as shown in Figure 1 and Figure 2. Connecting the capacitors as close to the LOG112 and LOG2112 as possible will contribute to noise reduction as well.

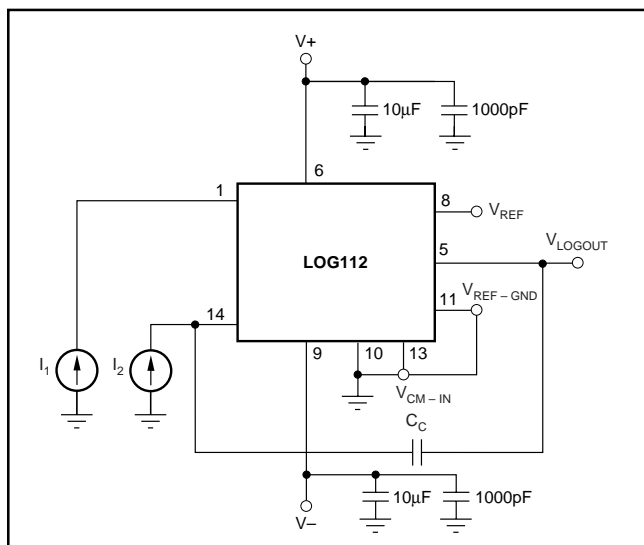

FIGURE 1. Basic Connections of the LOG112.

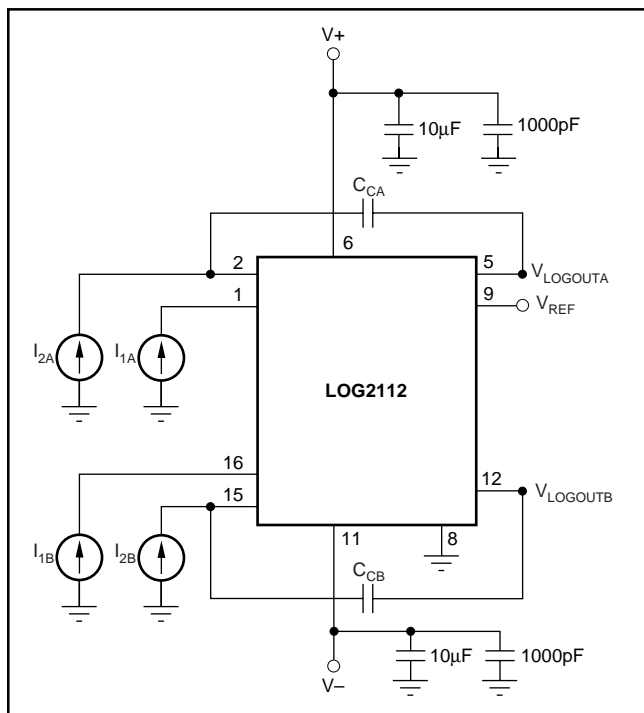

FIGURE 2. Basic Connections of the LOG2112.

## INPUT CURRENT RANGE

To maintain specified accuracy, the input current range of the LOG112 and LOG2112 should be limited from 100pA to 3.5mA. Input currents outside of this range may compromise the LOG112 performance. Input currents larger than 3.5mA result in increased nonlinearity. An absolute maximum input current rating of 10mA is included to prevent excessive power dissipation that may damage the input transistor.

On ±5V supplies, the total input current ( $I_1 + I_2$ ) is limited to 4.5mA. Due to compliance issues internal to the LOG112 and LOG2112, to accommodate larger total input currents, supplies should be increased.

## SETTING THE REFERENCE CURRENT

When the LOG112 and LOG2112 are used to compute logarithms, either  $I_1$  or  $I_2$  can be held constant to become the reference current to which the other is compared.

$V_{LOGOUT}$  is expressed as:

$$V_{LOGOUT} = (0.5V) \text{LOG} (I_1/I_{REF}) \quad (1)$$

$I_{REF}$  can be derived from an external current source (such as that shown in Figure 3), or it may be derived from a voltage source with one or more resistors. When a single resistor is used, the value may be large depending on  $I_{REF}$ . If  $I_{REF}$  is 10nA and +2.5V is used:

$$R_{REF} = 2.5V/10nA = 250M\Omega \quad (2)$$

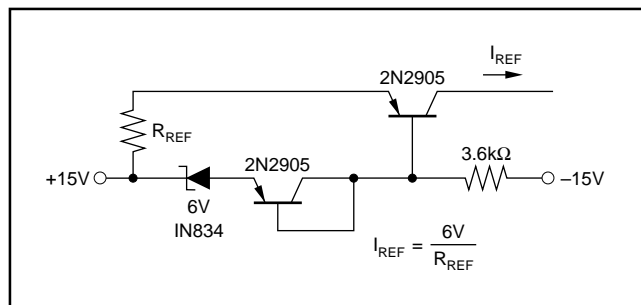

FIGURE 3. Temperature Compensated Current Source.

A voltage divider may be used to reduce the value of the resistor, as shown in Figure 4. When using this method, one must consider the possible errors caused by the amplifier's input offset voltage. The input offset voltage of amplifier  $A_1$  has a maximum value of 1.5mV, making  $V_{REF}$  a suggested value of 100mV.

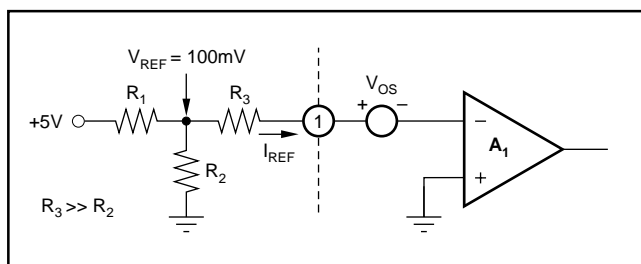

FIGURE 4. T Network for Reference Current.

Figure 5 shows a low-level current source using a series resistor. The low offset op amp reduces the effect of the LOG112 and LOG2112's input offset voltage.

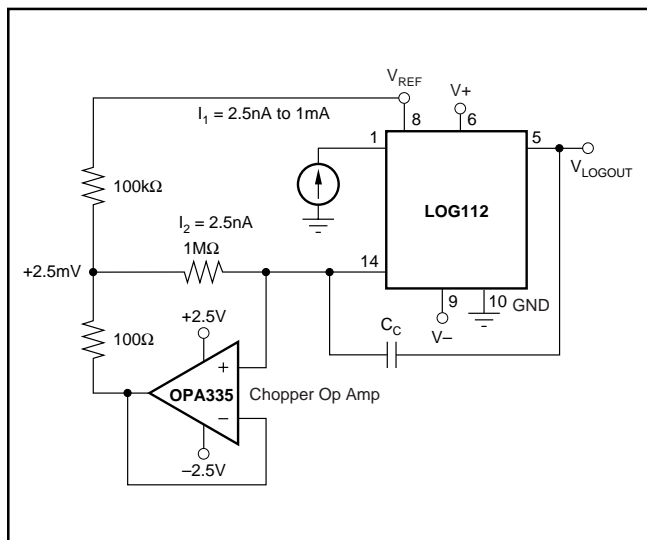

FIGURE 5. Current Source with Offset Compensation.

## FREQUENCY RESPONSE

The frequency response curves seen in the Typical Characteristic curves are shown for constant DC  $I_1$  and  $I_2$  with a small-signal AC current on one input.

The 3dB frequency response of the LOG112 and LOG2112 are a function of the magnitude of the input current levels and of the value of the frequency compensation capacitor. See Typical Characteristic curve, *3dB Frequency Response* for details.

The transient response of the LOG112 and LOG2112 are different for increasing and decreasing signals. This is due to the fact that a log amp is a nonlinear gain element and has different gains at different levels of input signals. Smaller input currents require greater gain to maintain full dynamic range, and will slow the frequency response of the LOG112 and LOG2112.

## FREQUENCY COMPENSATION

Frequency compensation for the LOG112 is obtained by connecting a capacitor between pins 5 and 14. Frequency compensation for the LOG2112 is obtained by connecting a capacitor between pins 2 and 5, or 15 and 12. The size of the capacitor is a function of the input currents, as shown in the Typical Characteristic curves (*Minimum Value of Compensation Capacitor*). For any given application, the smallest value of the capacitor which may be used is determined by the maximum value of  $I_2$  and the minimum value of  $I_1$ . Larger values of  $C_C$  make the LOG112 and LOG2112 more stable, but reduce the frequency response.

In an application, highest overall bandwidth can be achieved by detecting the signal level at  $V_{OUT}$ , then switching in appropriate values of compensation capacitors.

## NEGATIVE INPUT CURRENTS

The LOG112 and LOG2112 function only with positive input currents (conventional current flows into input current pins). In situations where negative input currents are needed, the circuits in Figures 6, 7, and 8 may be used.

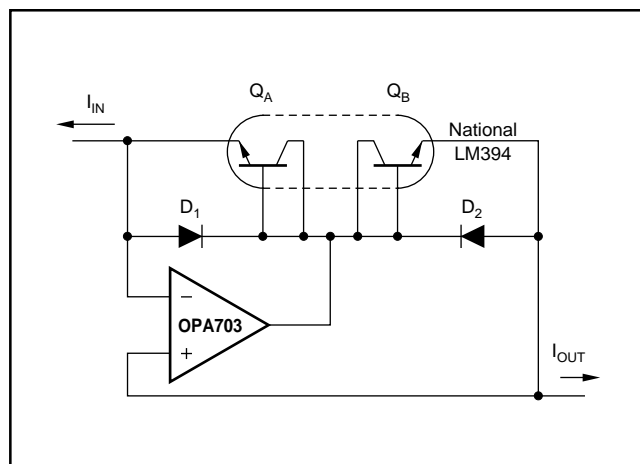
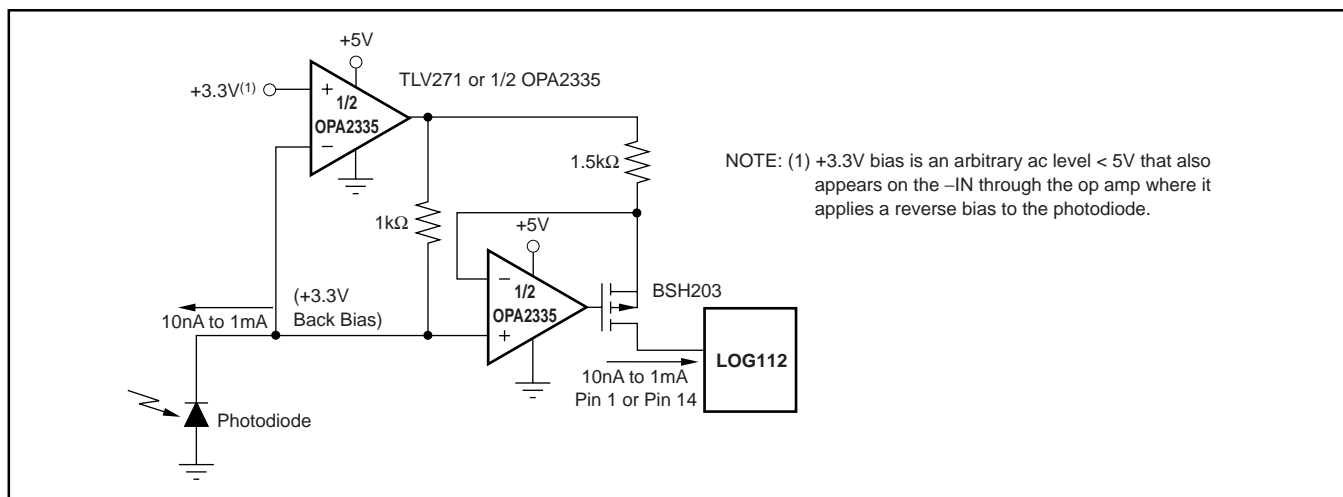

FIGURE 6. Current Inverter/Current Source.



NOTE: (1) +3.3V bias is an arbitrary ac level < 5V that also appears on the -IN through the op amp where it applies a reverse bias to the photodiode.

FIGURE 7. Precision Current Inverter/Current Source.

## VOLTAGE INPUTS

The LOG112 and LOG2112 give the best performances with current inputs. Voltage inputs may be handled directly with series resistors, but the dynamic input range is limited to approximately three decades of input voltage by voltage noise and offsets. The transfer function of Equation 13 applies to this configuration.

## ACHIEVING HIGHER ACCURACY WITH HIGHER INPUT CURRENTS

As input current to the LOG112 increases, output accuracy degrades. For a 4.5mA input current on  $\pm 5V$  supplies and a 10mA input current on  $\pm 12V$  supplies, total output error can be between 15% and 25%. Applying a common-mode volt-

age to  $V_{CM}$  of at least +1V and up to 2.5V, brings the log transistors out of saturation and reduces output error to approximately 10%. To avoid forward biasing a photodiode, return the cathode to the  $V_{CM}$  pin, as shown in Figure 9. To reverse bias the photodiode, apply a more positive voltage to the cathode than the anode.

## APPLICATION CIRCUITS

### LOG RATIO

One of the more common uses of log ratio amplifiers is to measure absorbance. See Figure 10 for a typical application.

$$\text{Absorbance of the sample is } A = \log \lambda_1' / \lambda_1 \quad (3)$$

$$\text{If } D_1 \text{ and } D_2 \text{ are matched } A \propto (0.5V) \log I_1 / I_2 \quad (4)$$

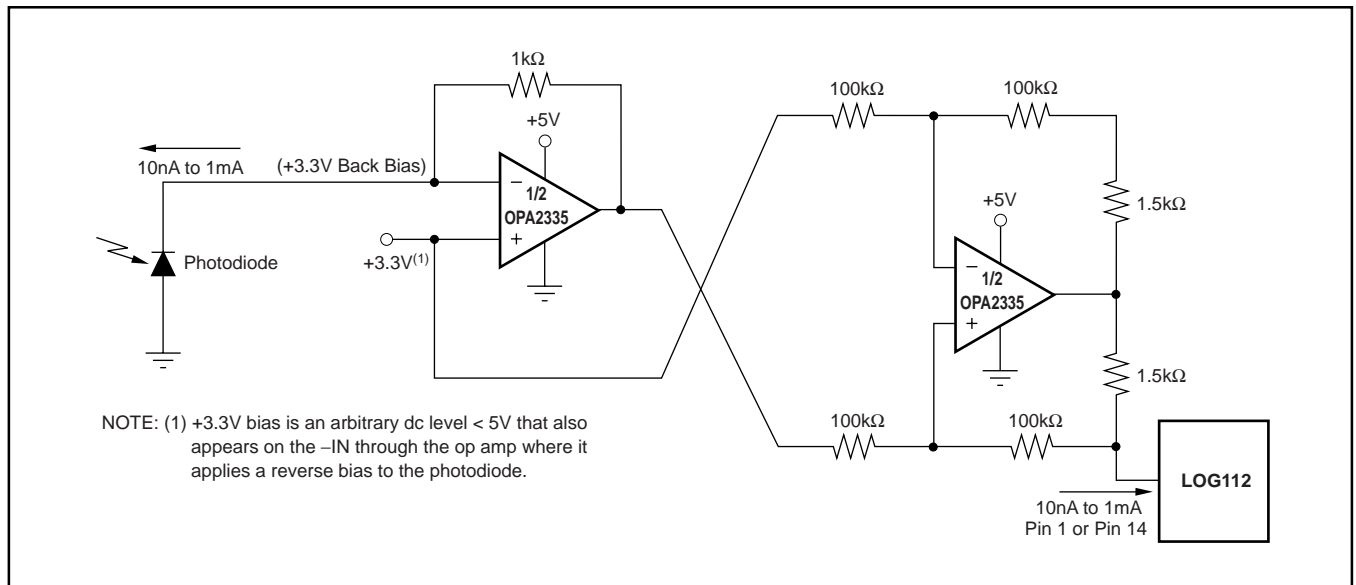

FIGURE 8. Precision Current Inverter/Current Source.

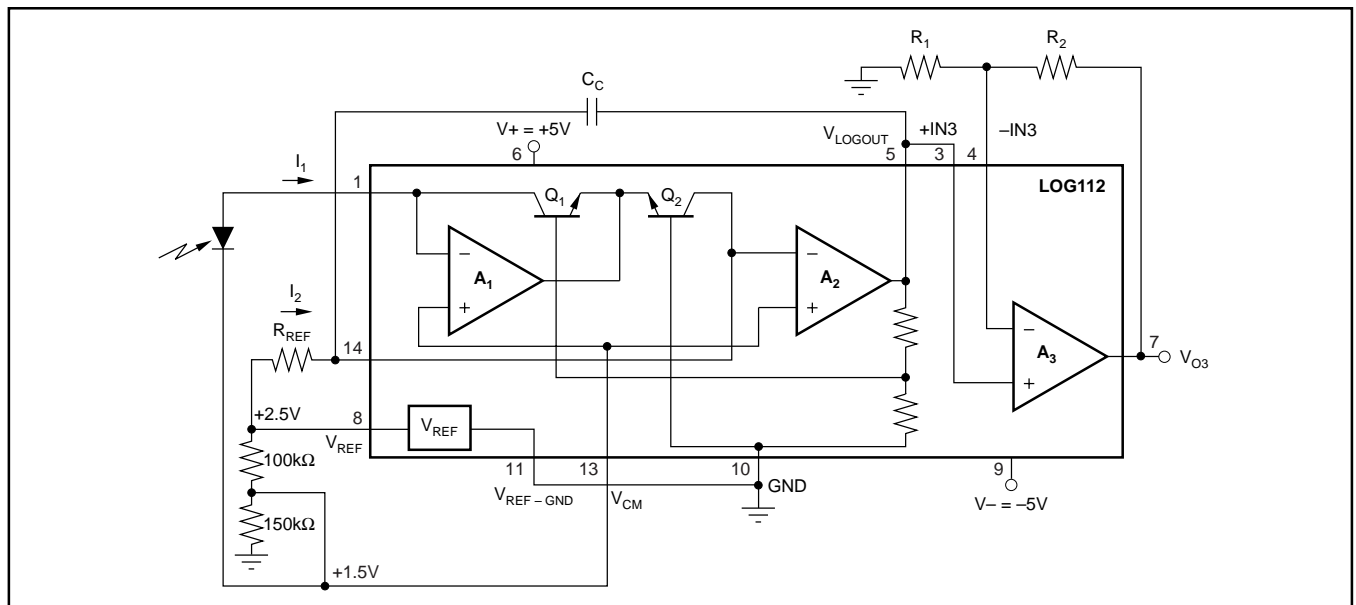

FIGURE 9. Extending Input Current Level and Improving Accuracy by Applying a Common-Mode Voltage.

## DATA COMPRESSION

In many applications, the compressive effects of the logarithmic transfer function are useful. For example, a LOG112 preceding a 12-bit A/D converter can produce the dynamic range equivalent to a 20-bit converter.

## OPERATION ON SINGLE SUPPLY

Many applications do not have the dual supplies required to operate the LOG112 and LOG2112. Figure 11 shows the LOG112 and LOG2112 configured for operation with a single +5V supply.

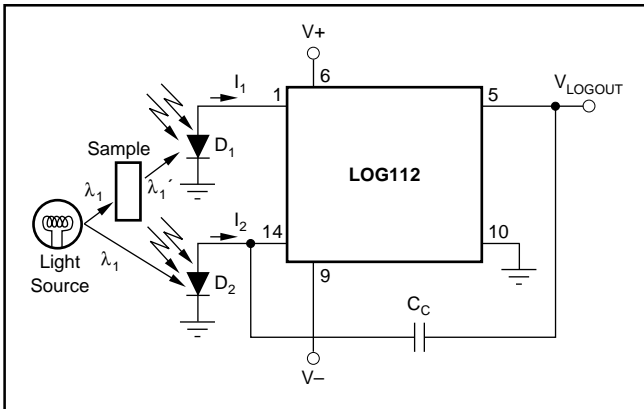

FIGURE 10. Absorbance Measurement.

## MEASURING AVALANCHE PHOTODIODE CURRENT

The wide dynamic range of the LOG112 and LOG2112 is useful for measuring avalanche photodiode current (APD), as shown in Figure 12.

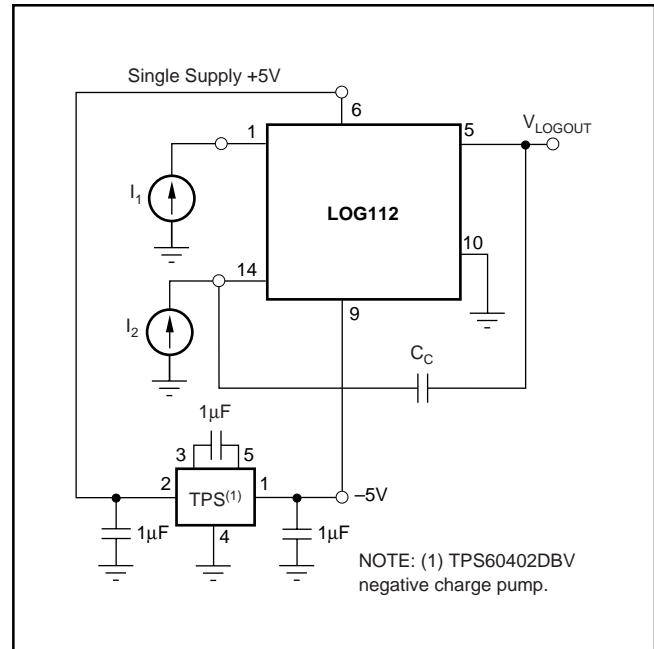

FIGURE 11. Single +5V Power-Supply Operation.

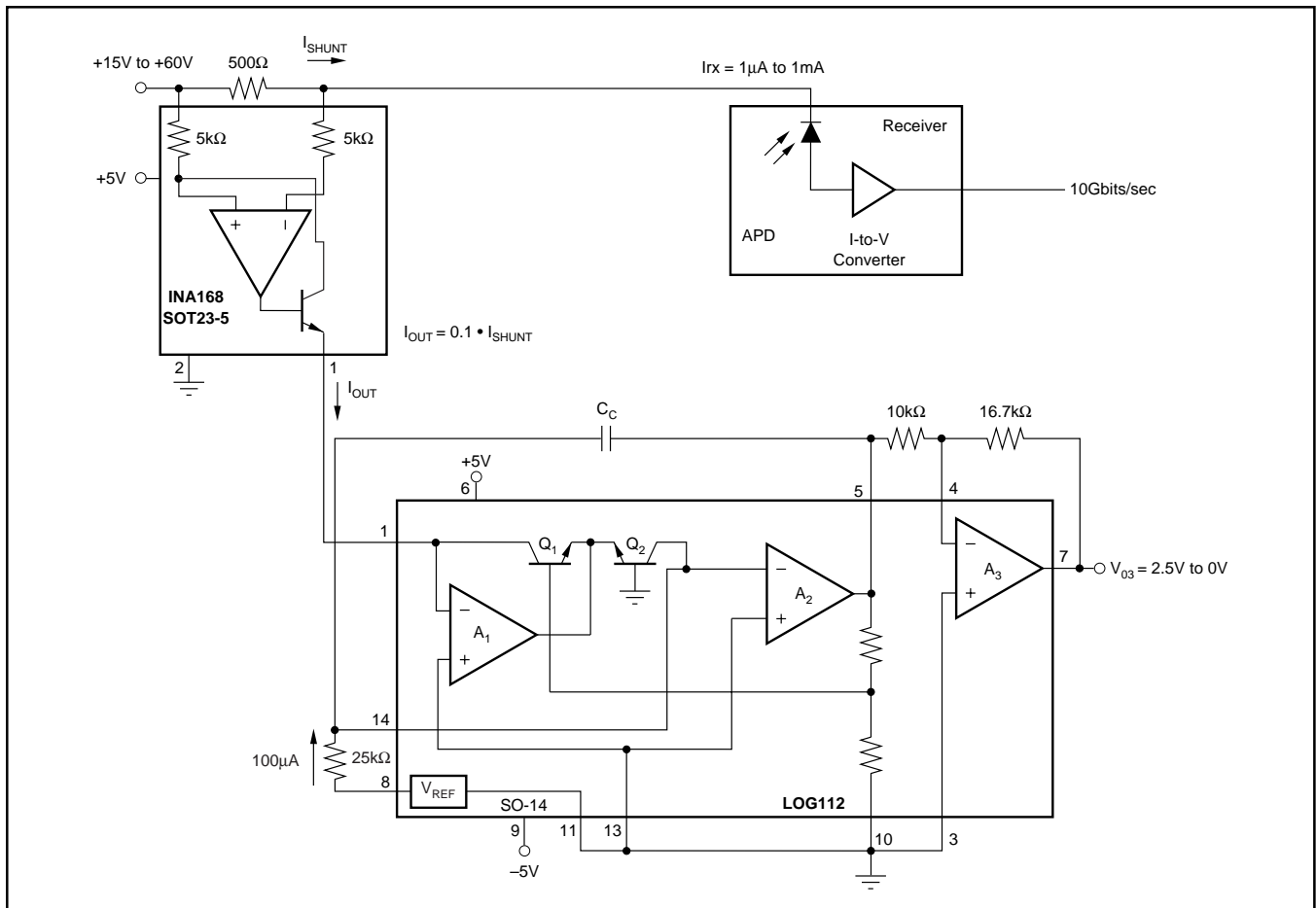

FIGURE 12. High-Side Shunt for APD Measures 3 Decades of APD Current.

# INSIDE THE LOG112

Using the base-emitter voltage relationship of matched bipolar transistors, the LOG112 establishes a logarithmic function of input current ratios. Beginning with the base-emitter voltage defined as:

$$V_{BE} = V_T \ln \frac{I_C}{I_S} \quad \text{where: } V_T = \frac{kT}{q} \quad (1)$$

$k$  = Boltzmann's constant =  $1.381 \cdot 10^{-23}$

$T$  = Absolute temperature in degrees Kelvin

$q$  = Electron charge =  $1.602 \cdot 10^{-19}$  Coulombs

$I_C$  = Collector current

$I_S$  = Reverse saturation current

From the circuit in Figure 12:

$$V_L = V_{BE1} - V_{BE2} \quad (2)$$

Substituting (1) into (2) yields:

$$V_L = V_{T1} \ln \frac{I_1}{I_{S1}} - V_{T2} \ln \frac{I_2}{I_{S2}} \quad (3)$$

If the transistors are matched and isothermal and  $V_{T1} = V_{T2}$ , then (3) becomes:

$$V_L = V_{T1} \left[ \ln \frac{I_1}{I_S} - \ln \frac{I_2}{I_S} \right] \quad (4)$$

$$V_L = V_T \ln \frac{I_1}{I_2} \quad \text{and since} \quad (5)$$

$$\ln x = 2.3 \log_{10} x \quad (6)$$

$$V_L = n V_T \log \frac{I_1}{I_2} \quad (7)$$

$$\text{where } n = 2.3 \quad (8)$$

also

$$V_{OUT} = V_L \frac{R_1 + R_2}{R_1} \quad (9)$$

$$V_{OUT} = \frac{R_1 + R_2}{R_1} n V_T \log \frac{I_1}{I_2} \quad (10)$$

or

$$V_{OUT} = (0.5V) \text{LOG} \left( \frac{I_1}{I_2} \right) \quad (11)$$

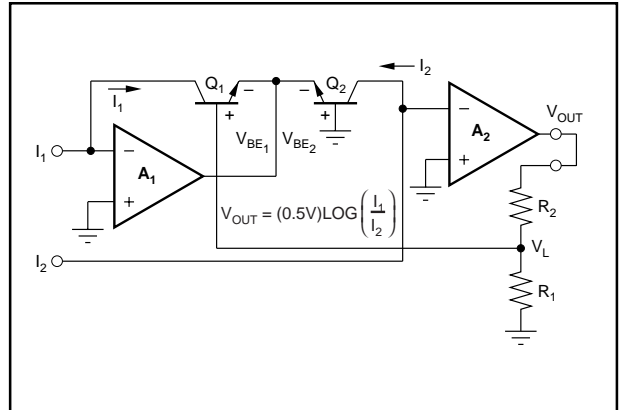

FIGURE 13. Simplified Model of a Log Amplifier.

NOTE:  $R_1$  is a metal resistor used to compensate for gain over temperature.

## DEFINITION OF TERMS

### TRANSFER FUNCTION

The ideal transfer function is:

$$V_{\text{LOGOUT}} = (0.5V) \text{LOG} (I_1/I_2)$$

Figure 14 shows the graphical representation of the transfer over valid operating range for the LOG112 and LOG2112.

### ACCURACY

Accuracy considerations for a log ratio amplifier are somewhat more complicated than for other amplifiers. This is because the transfer function is nonlinear and has two inputs, each of which can vary over a wide dynamic range. The accuracy for any combination of inputs is determined from the total error specification.

### TOTAL ERROR

The total error is the deviation (expressed in mV) of the actual output from the ideal output of  $V_{\text{LOGOUT}} = (0.5V) \text{LOG} (I_1/I_2)$ .

Thus,

$$V_{\text{LOGOUT(ACTUAL)}} = V_{\text{LOGOUT(IDEAL)}} \pm \text{Total Error} \quad (6)$$

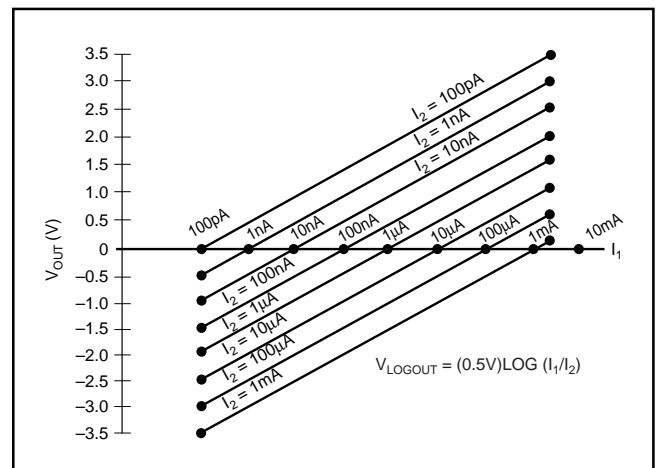

FIGURE 14. Transfer Function with Varying  $I_2$  and  $I_1$ .

It represents the sum of all the individual components of error normally associated with the log amp when operated in the current input mode. The worst-case error for any given ratio of  $I_1/I_2$  is the largest of the two errors when  $I_1$  and  $I_2$  are considered separately. Temperature can affect total error.

## ERRORS RTO AND RTI

As with any transfer function, errors generated by the function may be Referred-to-Output (RTO) or Referred-to-Input (RTI). In this respect, log amps have a unique property: given some error voltage at the log amp's output, that error corresponds to a constant percent of the input regardless of the actual input level.

## LOG CONFORMITY

For the LOG112 and LOG2112, log conformity is calculated the same as linearity and is plotted  $I_1/I_2$  on a semi-log scale. In many applications, log conformity is the most important specification. This is true because bias current errors are negligible (5pA compared to input currents of 100pA and above) and the scale factor and offset errors may be trimmed to zero or removed by system calibration. This leaves log conformity as the major source of error.

Log conformity is defined as the peak deviation from the best fit straight line of the  $V_{\text{LOGOUT}}$  versus  $\log(I_1/I_2)$  curve. This is expressed as a percent of ideal full-scale output. Thus, the nonlinearity error expressed in volts over  $m$  decades is:

$$V_{\text{LOGOUT (NONLIN)}} = 0.5V/\text{dec} \cdot 2NmV \quad (7)$$

where  $N$  is the log conformity error, in percent.

## INDIVIDUAL ERROR COMPONENTS

The ideal transfer function with current input is:

$$V_{\text{LOGOUT}} = (0.5V)\text{LOG}\left(\frac{I_1}{I_2}\right) \quad (8)$$

The actual transfer function with the major components of error is:

$$V_{\text{LOGOUT}} = (0.5V)(1 \pm \Delta K) \log\left(\frac{I_1 - I_{B1}}{I_2 - I_{B2}}\right) \pm Nm \pm V_{\text{OSO}} \quad (9)$$

The individual component of error is:

$\Delta K$  = gain error (0.10%, typ), as specified in the specification table.

$I_{B1}$  = bias current of  $A_1$  (5pA, typ)

$I_{B2}$  = bias current of  $A_2$  (5pA, typ)

$N$  = log conformity error (0.01%, 0.13%, typ)

0.01% for  $m = 5$ , 0.13% for  $m = 7.5$

$V_{\text{OSO}}$  = output offset voltage (3mV, typ)

$m$  = number of decades over which  $N$  is specified

For example, what is the error when:

$$I_1 = 1\mu\text{A} \text{ and } I_2 = 100\text{nA} \quad (10)$$

(11)

$$V_{\text{LOGOUT}} = (0.5 \pm 0.001) \log\left(\frac{10^{-6} - 5 \cdot 10^{-12}}{10^{-7} - 5 \cdot 10^{-12}}\right) \pm (2)(0.0001)5 \pm 3.0\text{mV}$$

$$= 0.505V$$

Since the ideal output is 0.5V, the error as a percent of the reading is:

$$\% \text{ error} = \frac{0.505V}{0.5} \cdot 100\% = 1.01\% \quad (12)$$

For the case of voltage inputs, the actual transfer function is:

(13)

$$V_{\text{LOGOUT}} = (0.5V)(1 \pm \Delta K) \log\left(\frac{\frac{V_1}{R_1} - I_{B1} \pm \frac{E_{\text{OS1}}}{R_1}}{\frac{V_2}{R_2} - I_{B2} \pm \frac{E_{\text{OS2}}}{R_2}}\right) \pm Nm \pm V_{\text{OSO}}$$

Where  $\frac{E_{\text{OS1}}}{R_1}$  and  $\frac{E_{\text{OS2}}}{R_2}$  (offset error) are considered to be zero for large values of resistance from external input current sources.

**PACKAGING INFORMATION**

Orderable Device	Status <sup>(1)</sup>	Package Type	Package Drawing	Pins	Package Qty	Eco Plan <sup>(2)</sup>	Lead/Ball Finish	MSL Peak Temp <sup>(3)</sup>
LOG112AID	ACTIVE	SOIC	D	14	50	Green (RoHS & no Sb/Br)	CU NIPDAU	Level-3-260C-168 HR
LOG112AIDE4	ACTIVE	SOIC	D	14	50	Green (RoHS & no Sb/Br)	CU NIPDAU	Level-3-260C-168 HR
LOG112AIDR	ACTIVE	SOIC	D	14	2500	Green (RoHS & no Sb/Br)	CU NIPDAU	Level-3-260C-168 HR
LOG112AIDRE4	ACTIVE	SOIC	D	14	2500	Green (RoHS & no Sb/Br)	CU NIPDAU	Level-3-260C-168 HR
LOG2112AIDW	ACTIVE	SOIC	DW	16	40	Green (RoHS & no Sb/Br)	CU NIPDAU	Level-3-260C-168 HR
LOG2112AIDWE4	ACTIVE	SOIC	DW	16	40	Green (RoHS & no Sb/Br)	CU NIPDAU	Level-3-260C-168 HR
LOG2112AIDWR	ACTIVE	SOIC	DW	16	1000	Green (RoHS & no Sb/Br)	CU NIPDAU	Level-3-260C-168 HR
LOG2112AIDWRE4	ACTIVE	SOIC	DW	16	1000	Green (RoHS & no Sb/Br)	CU NIPDAU	Level-3-260C-168 HR

<sup>(1)</sup> The marketing status values are defined as follows:

**ACTIVE:** Product device recommended for new designs.

**LIFEBUY:** TI has announced that the device will be discontinued, and a lifetime-buy period is in effect.

**NRND:** Not recommended for new designs. Device is in production to support existing customers, but TI does not recommend using this part in a new design.

**PREVIEW:** Device has been announced but is not in production. Samples may or may not be available.

**OBSOLETE:** TI has discontinued the production of the device.

<sup>(2)</sup> Eco Plan - The planned eco-friendly classification: Pb-Free (RoHS), Pb-Free (RoHS Exempt), or Green (RoHS & no Sb/Br) - please check <http://www.ti.com/productcontent> for the latest availability information and additional product content details.

**TBD:** The Pb-Free/Green conversion plan has not been defined.

**Pb-Free (RoHS):** TI's terms "Lead-Free" or "Pb-Free" mean semiconductor products that are compatible with the current RoHS requirements for all 6 substances, including the requirement that lead not exceed 0.1% by weight in homogeneous materials. Where designed to be soldered at high temperatures, TI Pb-Free products are suitable for use in specified lead-free processes.

**Pb-Free (RoHS Exempt):** This component has a RoHS exemption for either 1) lead-based flip-chip solder bumps used between the die and package, or 2) lead-based die adhesive used between the die and leadframe. The component is otherwise considered Pb-Free (RoHS compatible) as defined above.

**Green (RoHS & no Sb/Br):** TI defines "Green" to mean Pb-Free (RoHS compatible), and free of Bromine (Br) and Antimony (Sb) based flame retardants (Br or Sb do not exceed 0.1% by weight in homogeneous material)

<sup>(3)</sup> MSL, Peak Temp. -- The Moisture Sensitivity Level rating according to the JEDEC industry standard classifications, and peak solder temperature.

**Important Information and Disclaimer:**The information provided on this page represents TI's knowledge and belief as of the date that it is provided. TI bases its knowledge and belief on information provided by third parties, and makes no representation or warranty as to the accuracy of such information. Efforts are underway to better integrate information from third parties. TI has taken and continues to take reasonable steps to provide representative and accurate information but may not have conducted destructive testing or chemical analysis on incoming materials and chemicals. TI and TI suppliers consider certain information to be proprietary, and thus CAS numbers and other limited information may not be available for release.

In no event shall TI's liability arising out of such information exceed the total purchase price of the TI part(s) at issue in this document sold by TI to Customer on an annual basis.

**TAPE AND REEL INFORMATION**
**REEL DIMENSIONS**

**TAPE DIMENSIONS**

A0	Dimension designed to accommodate the component width
B0	Dimension designed to accommodate the component length
K0	Dimension designed to accommodate the component thickness
W	Overall width of the carrier tape
P1	Pitch between successive cavity centers

**TAPE AND REEL INFORMATION**

\*All dimensions are nominal

Device	Package Type	Package Drawing	Pins	SPQ	Reel Diameter (mm)	Reel Width W1 (mm)	A0 (mm)	B0 (mm)	K0 (mm)	P1 (mm)	W (mm)	Pin1 Quadrant
LOG112AIDR	SOIC	D	14	2500	330.0	16.4	6.5	9.0	2.1	8.0	16.0	Q1
LOG2112AIDWR	SOIC	DW	16	1000	330.0	16.4	10.75	10.7	2.7	12.0	16.0	Q1

TAPE AND REEL BOX DIMENSIONS



\*All dimensions are nominal

Device	Package Type	Package Drawing	Pins	SPQ	Length (mm)	Width (mm)	Height (mm)
LOG112AIDR	SOIC	D	14	2500	367.0	367.0	38.0
LOG2112AIDWR	SOIC	DW	16	1000	367.0	367.0	38.0

D (R-PDSO-G14)

PLASTIC SMALL OUTLINE

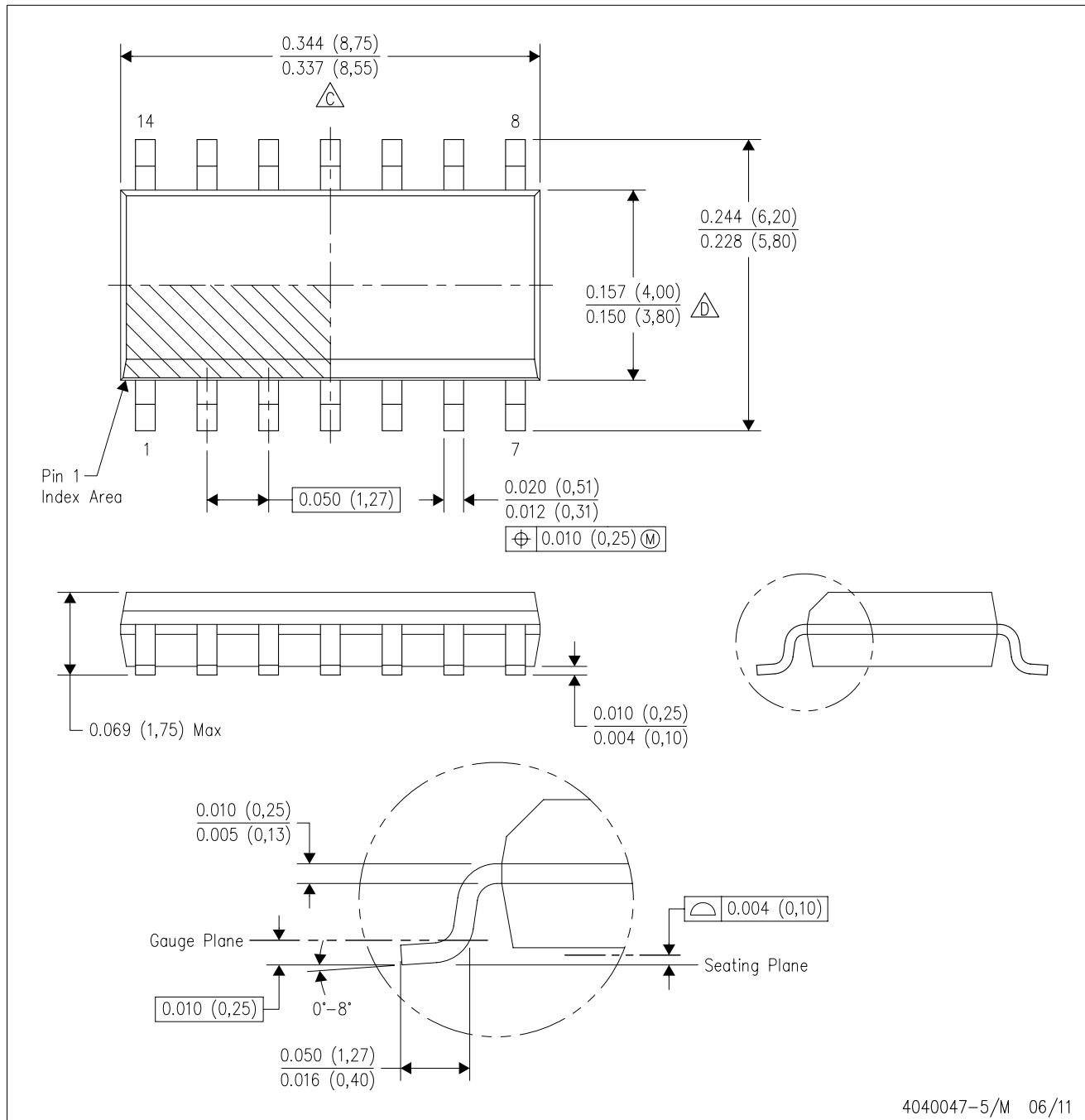

- NOTES:
- A. All linear dimensions are in inches (millimeters).
  - B. This drawing is subject to change without notice.
  - C. Body length does not include mold flash, protrusions, or gate burrs. Mold flash, protrusions, or gate burrs shall not exceed 0.006 (0,15) each side.
  - D. Body width does not include interlead flash. Interlead flash shall not exceed 0.017 (0,43) each side.
  - E. Reference JEDEC MS-012 variation AB.

D (R-PDSO-G14)

PLASTIC SMALL OUTLINE

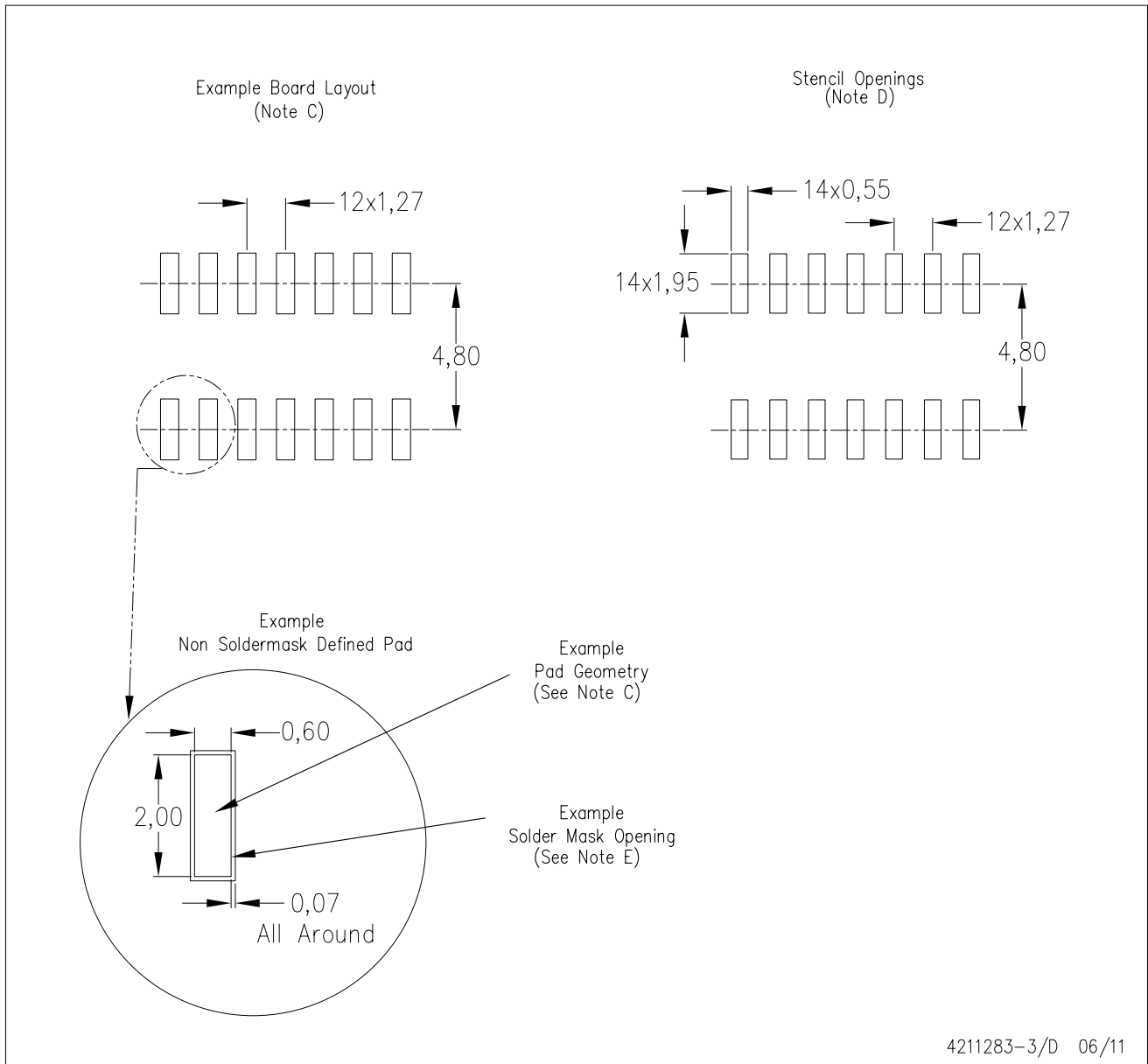

- NOTES:
- A. All linear dimensions are in millimeters.
  - B. This drawing is subject to change without notice.
  - C. Publication IPC-7351 is recommended for alternate designs.
  - D. Laser cutting apertures with trapezoidal walls and also rounding corners will offer better paste release. Customers should contact their board assembly site for stencil design recommendations. Refer to IPC-7525 for other stencil recommendations.
  - E. Customers should contact their board fabrication site for solder mask tolerances between and around signal pads.

DW (R-PDSO-G16)

PLASTIC SMALL OUTLINE



- NOTES:
- A. All linear dimensions are in inches (millimeters). Dimensioning and tolerancing per ASME Y14.5M-1994.
  - B. This drawing is subject to change without notice.
  - C. Body dimensions do not include mold flash or protrusion not to exceed 0.006 (0,15).
  - D. Falls within JEDEC MS-013 variation AA.

DW (R-PDSO-G16)

PLASTIC SMALL OUTLINE

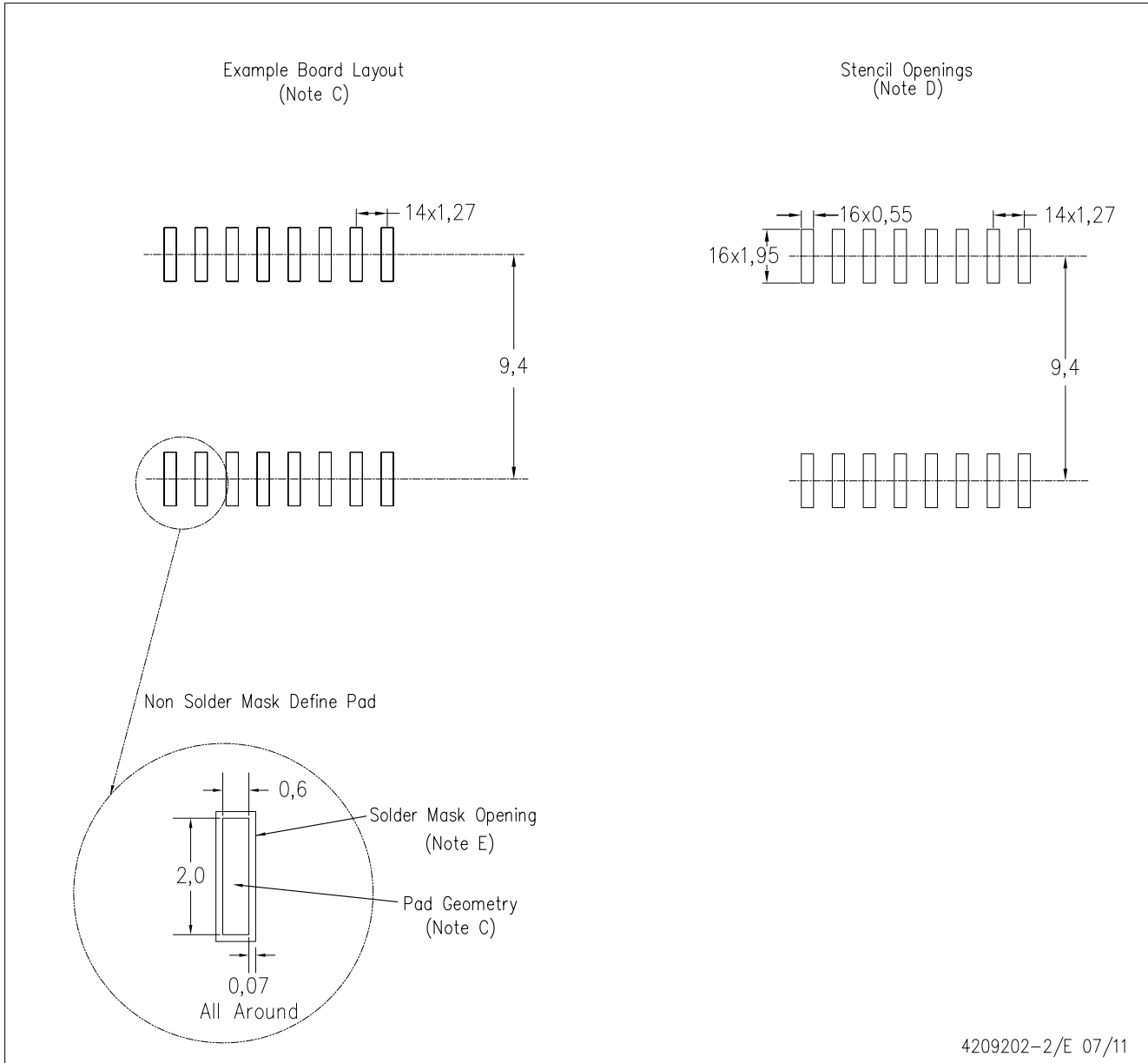

4209202-2/E 07/11

- NOTES:
- A. All linear dimensions are in millimeters.
  - B. This drawing is subject to change without notice.
  - C. Refer to IPC7351 for alternate board design.
  - D. Laser cutting apertures with trapezoidal walls and also rounding corners will offer better paste release. Customers should contact their board assembly site for stencil design recommendations. Refer to IPC-7525
  - E. Customers should contact their board fabrication site for solder mask tolerances between and around signal pads.

## IMPORTANT NOTICE

Texas Instruments Incorporated and its subsidiaries (TI) reserve the right to make corrections, enhancements, improvements and other changes to its semiconductor products and services per JESD46C and to discontinue any product or service per JESD48B. Buyers should obtain the latest relevant information before placing orders and should verify that such information is current and complete. All semiconductor products (also referred to herein as "components") are sold subject to TI's terms and conditions of sale supplied at the time of order acknowledgment.

TI warrants performance of its components to the specifications applicable at the time of sale, in accordance with the warranty in TI's terms and conditions of sale of semiconductor products. Testing and other quality control techniques are used to the extent TI deems necessary to support this warranty. Except where mandated by applicable law, testing of all parameters of each component is not necessarily performed.

TI assumes no liability for applications assistance or the design of Buyers' products. Buyers are responsible for their products and applications using TI components. To minimize the risks associated with Buyers' products and applications, Buyers should provide adequate design and operating safeguards.

TI does not warrant or represent that any license, either express or implied, is granted under any patent right, copyright, mask work right, or other intellectual property right relating to any combination, machine, or process in which TI components or services are used. Information published by TI regarding third-party products or services does not constitute a license to use such products or services or a warranty or endorsement thereof. Use of such information may require a license from a third party under the patents or other intellectual property of the third party, or a license from TI under the patents or other intellectual property of TI.

Reproduction of significant portions of TI information in TI data books or data sheets is permissible only if reproduction is without alteration and is accompanied by all associated warranties, conditions, limitations, and notices. TI is not responsible or liable for such altered documentation. Information of third parties may be subject to additional restrictions.

Resale of TI components or services with statements different from or beyond the parameters stated by TI for that component or service voids all express and any implied warranties for the associated TI component or service and is an unfair and deceptive business practice. TI is not responsible or liable for any such statements.

Buyer acknowledges and agrees that it is solely responsible for compliance with all legal, regulatory and safety-related requirements concerning its products, and any use of TI components in its applications, notwithstanding any applications-related information or support that may be provided by TI. Buyer represents and agrees that it has all the necessary expertise to create and implement safeguards which anticipate dangerous consequences of failures, monitor failures and their consequences, lessen the likelihood of failures that might cause harm and take appropriate remedial actions. Buyer will fully indemnify TI and its representatives against any damages arising out of the use of any TI components in safety-critical applications.

In some cases, TI components may be promoted specifically to facilitate safety-related applications. With such components, TI's goal is to help enable customers to design and create their own end-product solutions that meet applicable functional safety standards and requirements. Nonetheless, such components are subject to these terms.

No TI components are authorized for use in FDA Class III (or similar life-critical medical equipment) unless authorized officers of the parties have executed a special agreement specifically governing such use.

Only those TI components which TI has specifically designated as military grade or "enhanced plastic" are designed and intended for use in military/aerospace applications or environments. Buyer acknowledges and agrees that any military or aerospace use of TI components which have **not** been so designated is solely at the Buyer's risk, and that Buyer is solely responsible for compliance with all legal and regulatory requirements in connection with such use.

TI has specifically designated certain components which meet ISO/TS16949 requirements, mainly for automotive use. Components which have not been so designated are neither designed nor intended for automotive use; and TI will not be responsible for any failure of such components to meet such requirements.

### Products

Audio	<a href="http://www.ti.com/audio">www.ti.com/audio</a>
Amplifiers	<a href="http://amplifier.ti.com">amplifier.ti.com</a>
Data Converters	<a href="http://dataconverter.ti.com">dataconverter.ti.com</a>
DLP® Products	<a href="http://www.dlp.com">www.dlp.com</a>
DSP	<a href="http://dsp.ti.com">dsp.ti.com</a>
Clocks and Timers	<a href="http://www.ti.com/clocks">www.ti.com/clocks</a>
Interface	<a href="http://interface.ti.com">interface.ti.com</a>
Logic	<a href="http://logic.ti.com">logic.ti.com</a>
Power Mgmt	<a href="http://power.ti.com">power.ti.com</a>
Microcontrollers	<a href="http://microcontroller.ti.com">microcontroller.ti.com</a>
RFID	<a href="http://www.ti-rfid.com">www.ti-rfid.com</a>
OMAP Mobile Processors	<a href="http://www.ti.com/omap">www.ti.com/omap</a>
Wireless Connectivity	<a href="http://www.ti.com/wirelessconnectivity">www.ti.com/wirelessconnectivity</a>

### Applications

Automotive and Transportation	<a href="http://www.ti.com/automotive">www.ti.com/automotive</a>
Communications and Telecom	<a href="http://www.ti.com/communications">www.ti.com/communications</a>
Computers and Peripherals	<a href="http://www.ti.com/computers">www.ti.com/computers</a>
Consumer Electronics	<a href="http://www.ti.com/consumer-apps">www.ti.com/consumer-apps</a>
Energy and Lighting	<a href="http://www.ti.com/energy">www.ti.com/energy</a>
Industrial	<a href="http://www.ti.com/industrial">www.ti.com/industrial</a>
Medical	<a href="http://www.ti.com/medical">www.ti.com/medical</a>
Security	<a href="http://www.ti.com/security">www.ti.com/security</a>
Space, Avionics and Defense	<a href="http://www.ti.com/space-avionics-defense">www.ti.com/space-avionics-defense</a>
Video and Imaging	<a href="http://www.ti.com/video">www.ti.com/video</a>

**TI E2E Community** [e2e.ti.com](http://e2e.ti.com)