



SoundPLUS™ Stereo Audio DIGITAL-TO-ANALOG CONVERTER With Programmable Dual PLL

FEATURES

- ACCEPTS 16-, 20-, OR 24-BIT INPUT DATA
- COMPLETE STEREO DAC: Includes Digital Filter and Output Amp
- DYNAMIC RANGE: 92dB
- MULTIPLE SAMPLING FREQUENCIES:
 $f_S = 44.1\text{kHz}$, 48kHz , 96kHz
- PROGRAMMABLE DUAL PLL CIRCUIT:
27MHz Master Clock Input
- GENERATED SYSTEM CLOCK
SCKO1: 33.8688MHz
SCKO2: $384f_S$
SCKO3: $768f_S$ ($44.1\text{k}/48\text{kHz}$)
 $384f_S$ (96kHz)
- NORMAL OR I²S™ DATA INPUT FORMATS
- SELECTABLE FUNCTIONS:
Soft Mute, Analog Output Mode
Digital Attenuator (256 Steps)
Digital De-Emphasis
- +5V SINGLE POWER SUPPLY

DESCRIPTION

The PCM1727 is a complete, low-cost, stereo audio digital-to-analog converter (DAC) with a dual phase-locked loop (PLL) circuit included. PLL-1 derives a fixed 33.8688MHz ($768f_S$, $f_S = 44.1\text{kHz}$) system clock (SCKO-1), and PLL-2 derives both the $384f_S$ ($f_S = 44.1\text{k}/48\text{kHz}$) system clock (SCKO-2) and the $768f_S$ ($f_S = 44.1\text{k}/48\text{kHz}$)/ $384f_S$ ($f_S = 96\text{kHz}$) system clock (SCKO-3) from an external 27MHz reference frequency. The DAC contains a 3rd-order Delta-Sigma ($\Delta\Sigma$) modulator, a digital interpolation filter, and an analog output amplifier. The PCM1727 can accept 16-, 20-, or 24-bit input data in either normal or I²S formats.

The digital filter performs an 8X interpolation function and includes selectable features such as soft mute, digital attenuation and digital de-emphasis.

The PCM1727 is ideal for applications that combine compressed audio and video data such as DVD, DVD Audio with CD-DA compatibility, and karaoke DSP.

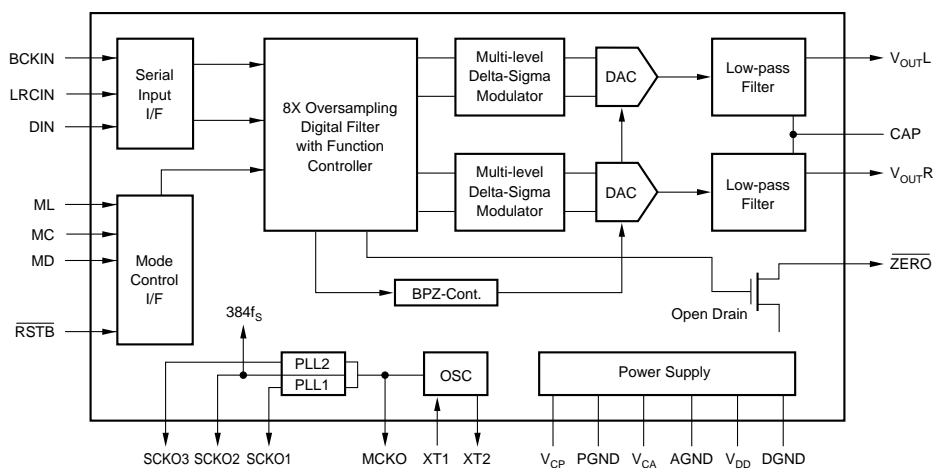

Please be aware that an important notice concerning availability, standard warranty, and use in critical applications of Texas Instruments semiconductor products and disclaimers thereto appears at the end of this data sheet.

SoundPLUS is a trademark of Texas Instruments.

I²S is a trademark of NXP Semiconductors.

All other trademarks are the property of their respective owners.

PRODUCTION DATA information is current as of publication date. Products conform to specifications per the terms of Texas Instruments standard warranty. Production processing does not necessarily include testing of all parameters.

ELECTROSTATIC DISCHARGE SENSITIVITY

This integrated circuit can be damaged by ESD. Texas Instruments recommends that all integrated circuits be handled with appropriate precautions. Failure to observe proper handling and installation procedures can cause damage.

ESD damage can range from subtle performance degradation to complete device failure. Precision integrated circuits may be more susceptible to damage because very small parametric changes could cause the device not to meet its published specifications.

ABSOLUTE MAXIMUM RATINGS⁽¹⁾

Power Supply Voltage	+6.5V
+V _{CC} to +V _{DD} Difference	±0.1V
Input Logic Voltage	-0.3V to (V _{DD} + 0.3V)
Input Current (except power supply)	±10mA
Power Dissipation	300mW
Operating Temperature Range	-25°C to +85°C
Storage Temperature	-55°C to +125°C
Lead Temperature (soldering, 5s)	+260°C
Thermal Resistance, θ_{JA}	+70°C/W

NOTE: (1) Stresses above those listed under Absolute Maximum Ratings may cause permanent damage to the device. Exposure to absolute maximum conditions for extended periods may affect device reliability.

PACKAGE INFORMATION⁽¹⁾

PRODUCT	PACKAGE	PACKAGE DESIGNATOR
PCM1727E	24-Pin SSOP	DB

NOTE: (1) For the most current package and ordering information, see the Package Option Addendum at the end of this data sheet, or see the TI website at www.ti.com.

PIN CONFIGURATION

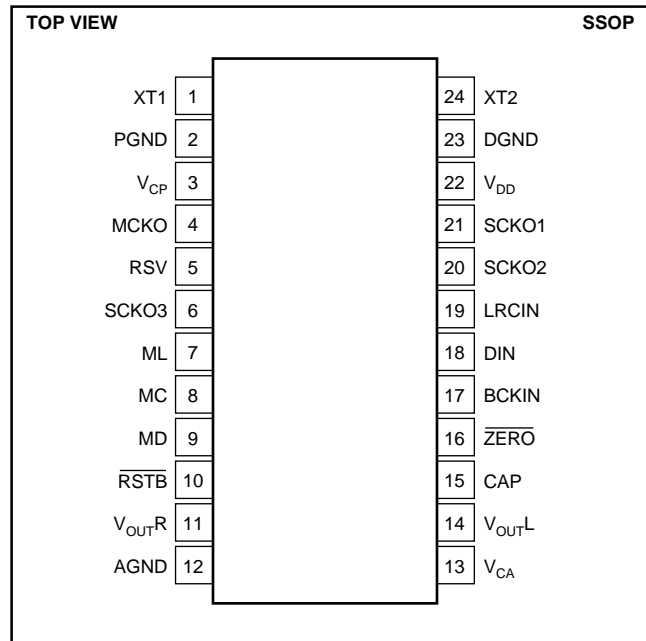

PIN ASSIGNMENTS

PIN	NAME	I/O	DESCRIPTION
1	XT1	IN	27MHz Crystal or External Clock Input
2	PGND	—	PLL Ground
3	V _{CP}	—	PLL Power Supply (+5V)
4	MCKO	OUT	Buffered Clock Output of Crystal Oscillator
5	RSV	—	Reserve; This pin should be open.
6	SCKO3	OUT	System Clock Out 3; This output is 768f _S or 384f _S .
7	ML	IN	Latch Enable Input for Serial Interface Mode ⁽²⁾
8	MC	IN	Bit Clock Input for Serial Interface Mode ⁽²⁾
9	MD	IN	Serial Data Input for Serial Interface Mode ⁽²⁾
10	RSTB	IN	Reset; When this pin is low, the DF and modulator are held in reset.
11	V _{OUTR}	OUT	Right Channel, Analog Voltage Output of Audio Signal
12	AGND	—	Analog Ground
13	V _{CA}	—	Analog Power Supply (+5V)
14	V _{OUTL}	OUT	Left Channel, Analog Voltage Output of Audio Signal
15	CAP	—	Common Pin of Analog Output Amp
16	ZERO	OUT	Zero Data Flag; This pin is low when the input data is continuously zero for more than 65,535 cycles of BCKIN ⁽¹⁾ .
17	BCKIN	IN	Bit Clock Input for Serial Audio Data ⁽³⁾
18	DIN	IN	Serial Audio Data Input ⁽³⁾
19	LRCIN	IN	Left and Right Clock (sampling rate=f _S) ⁽³⁾
20	SCKO2	OUT	System Clock Out 2; This output is 256f _S or 384f _S system clock.
21	SCKO1	OUT	System Clock Out 1; This output is 33.8688MHz system clock.
22	V _{DD}	—	Digital Power (+5V)
23	DGND	—	Digital Ground
24	XT2	—	27MHz Crystal. Connected to GND at external clock.

NOTES: (1) Open Drain Output.
 (2) Schmitt trigger input with internal pull-up resistors.
 (3) Schmitt trigger input.

ELECTRICAL CHARACTERISTICS

All specifications at +25°C, +V_{CA} = +V_{DD} = +V_{CP} = +5V, f_S = 44.1kHz, and 16-bit input data, SYSCLK = 384f_S, unless otherwise noted.

PARAMETER	CONDITIONS	PCM1727			UNITS
		MIN	TYP	MAX	
RESOLUTION		16			Bits
DATA FORMAT Audio Data Interface Format Data Bit Length Audio Data Format Sampling Frequency (f _S)			Standard/I ² S Selectable 16/20/24 Selectable MSB First, 2's Comp		
		44.1		96	kHz
PLL PERFORMANCE Master Clock Input Frequency ⁽⁴⁾ Generated System Clock SCKO-1 SCKO-2 SCKO-3 Output Logic Level V _{OH} (MCKO, SCKO 1 ~ 3) V _{OL} Generated SYSCLK Jitter Generated SYSCLK Transient ⁽¹⁾ Power-Up Time Generated SYSCLK Duty Cycle	768f _S (f _S = 44.1k) 384f _S 768f _S (f _S = 44.1k/48k), 384f _S (f _S = 96k) I _{OH} = 2mA I _{OL} = 4mA Standard Dev f _M = 27MHz To Programmed Frequency f _M = 27MHz, C _L = 15pF	26.73 16.9344 33.8688 40	27 33.8688 ±150 15 50	27.27 36.8640 36.8640 0.5 20 30 60	MHz MHz MHz VDC VDC ps ms ms %
DIGITAL INPUT LOGIC LEVEL			TTL		
DYNAMIC PERFORMANCE⁽²⁾ THD+N at f _S (0dB) THD+N at -60dB Dynamic Range (EIAJ Method) Signal-to-Noise Ratio ⁽³⁾ (EIAJ Method) Channel Separation	f _S = 44.1kHz f _S = 96kHz f _S = 44.1kHz f _S = 96kHz f _S = 44.1kHz f _S = 96kHz f _S = 44.1kHz f _S = 96kHz f _S = 44.1kHz		-89 -87 -31 -29 90 92 90 90 90 90 88	-80 90 92 90 90 90 90 93	dB dB dB dB dB dB dB dB dB dB dB
DC ACCURACY Gain Error Gain Mismatch, Channel-to-Channel Bipolar Zero Error	V _{OUT} = V _{CC} /2 at BPZ		±1.0 ±1.0 ±30	±3.0 ±2.0	% of FSR % of FSR mV
ANALOG OUTPUT Output Voltage Center Voltage Load Impedance	Full Scale (-0dB) AC Load		0.62 x V _{CA} V _{CA} /2 5		V _{PP} V _{DC} kΩ
DIGITAL FILTER PERFORMANCE Passband Stop Band Passband Ripple Stop Band Attenuation Delay Time De-emphasis Error		0.555		0.445 ±0.17 11.125/f _S +0.55	f _S f _S dB dB sec dB
INTERNAL ANALOG FILTER -3dB Bandwidth Passband Response	f = 20kHz		100 -0.16		kHz dB
POWER SUPPLY REQUIREMENTS Voltage Range Supply Current: I _{CC} + I _{DD} + I _{CP}	V _{CC} = V _{DD} = V _{CP} f _S = 44.1kHz	4.5	5 25	5.5 27	VDC mA
TEMPERATURE RANGE Operating Storage		-25 -55		+85 +125	°C °C

NOTES: (1) Sysclk transient is the maximum frequency lock time when the PLL frequency is changed.

(2) Dynamic performance specs are tested with 20kHz low pass filter and THD+N specs are tested with 30kHz LPF, 400Hz HPF, Average-Mode.

(3) SNR is tested at Infinite Zero Detection off.

(4) PLL evaluations tested with 1ns maximum jitter on the 27MHz input clock.

TYPICAL CHARACTERISTICS

At $T_A = +25^\circ\text{C}$, $V_{CC} = V_{DD} = V_{CP} = +5\text{V}$, $f_S = 44.1\text{kHz}$, 16-bit input data, $384f_S$, unless otherwise noted. Measurement bandwidth is 20kHz.

DYNAMIC PERFORMANCE

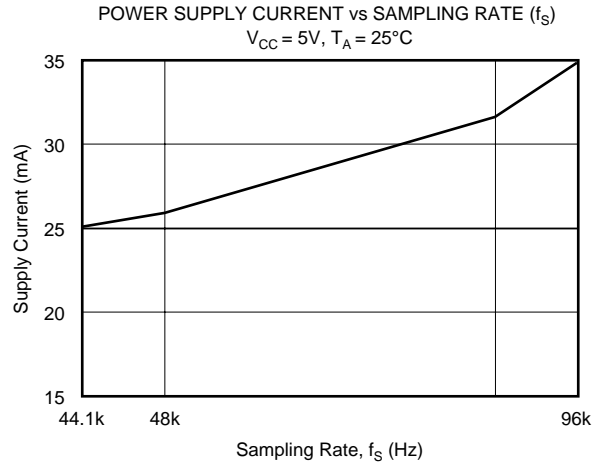
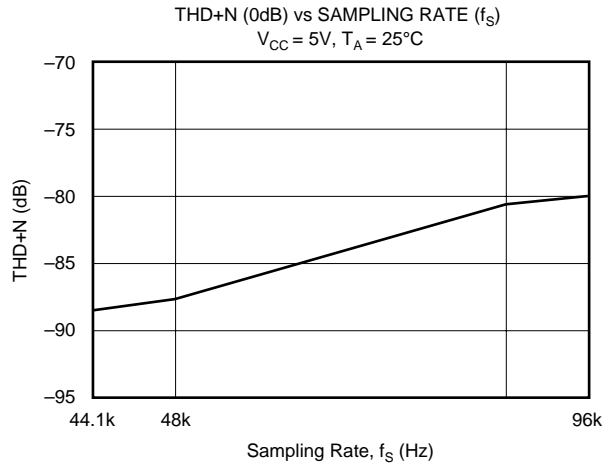
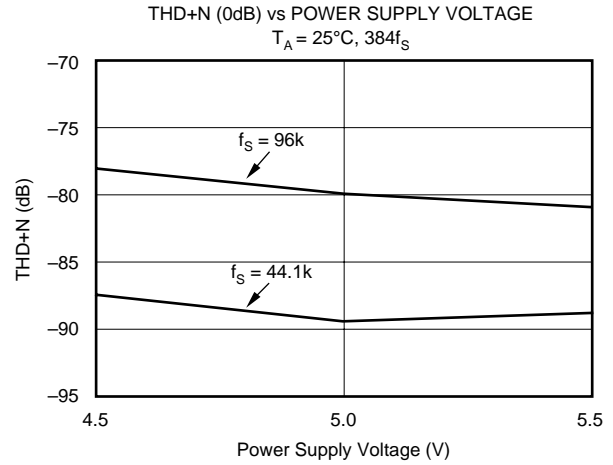
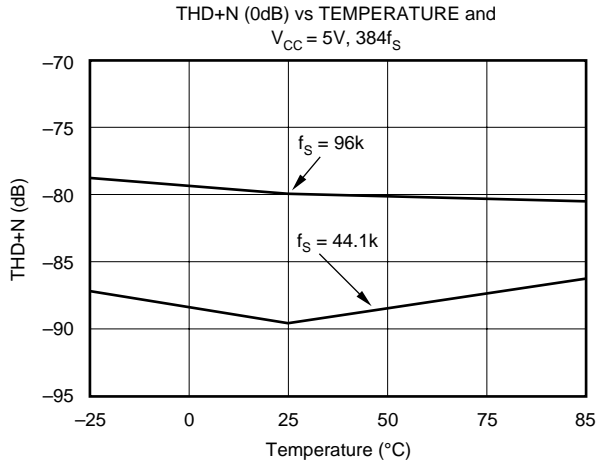

TYPICAL CHARACTERISTICS (Cont.)

DIGITAL FILTER

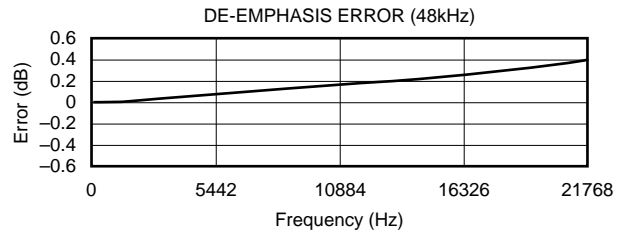
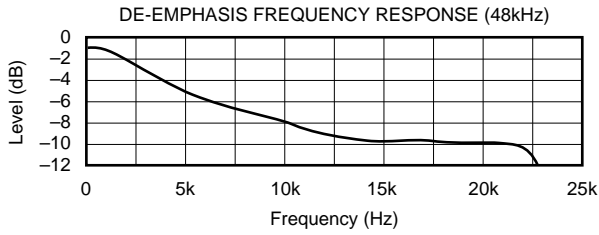
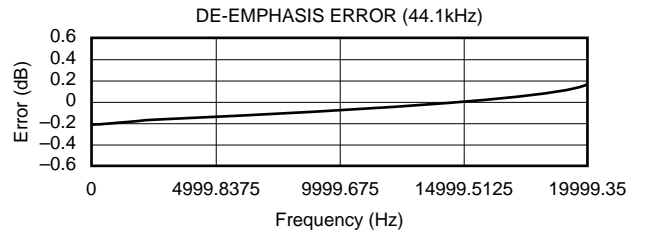
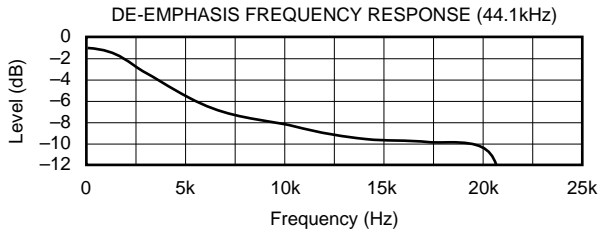
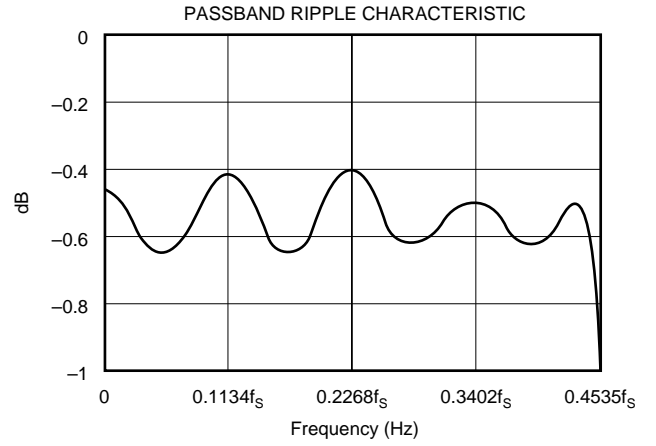
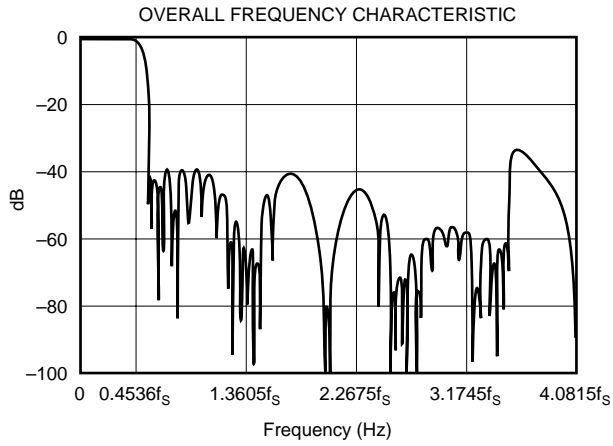

TYPICAL CONNECTION DIAGRAM

Figure 1 illustrates the typical connection diagram for the PCM1727 in a DVD Audio application. The 27MHz master video clock (f_M) drives XT1 (pin 1) of the PCM1727. A programmable system clock is generated by the PCM1727 PLL, with SCKO2 used to drive the MPEG2 decoder system clock input, SCKO1 used to drive the CD-DA DSP system clock input, and SCKO3 used to drive Karaoke DSP system clock input. The standard audio signals (data, bit clock, and word clock) are generated in the decoder from the PCM1727 system clock, providing synchronization of audio and video signals.

DUAL PLL CIRCUIT

The PCM1727 has a programmable internal DUAL PLL circuit, as shown in Figure 2. The PLL is designed to accept a 27MHz master clock or crystal oscillator and generate all internal system clocks required to operate the digital filter and $\Delta\Sigma$ modulator, at $384f_S$. If an external master clock is used, XT2 must be connected to ground. In both cases, the signal amplitude on XT1 must satisfy the specification described in Figure 3. Therefore, careful C1 and C2 determination is required to keep this specification satisfied when using a crystal oscillator. The PLL will directly track any variations in the master clock frequency, and jitter on the

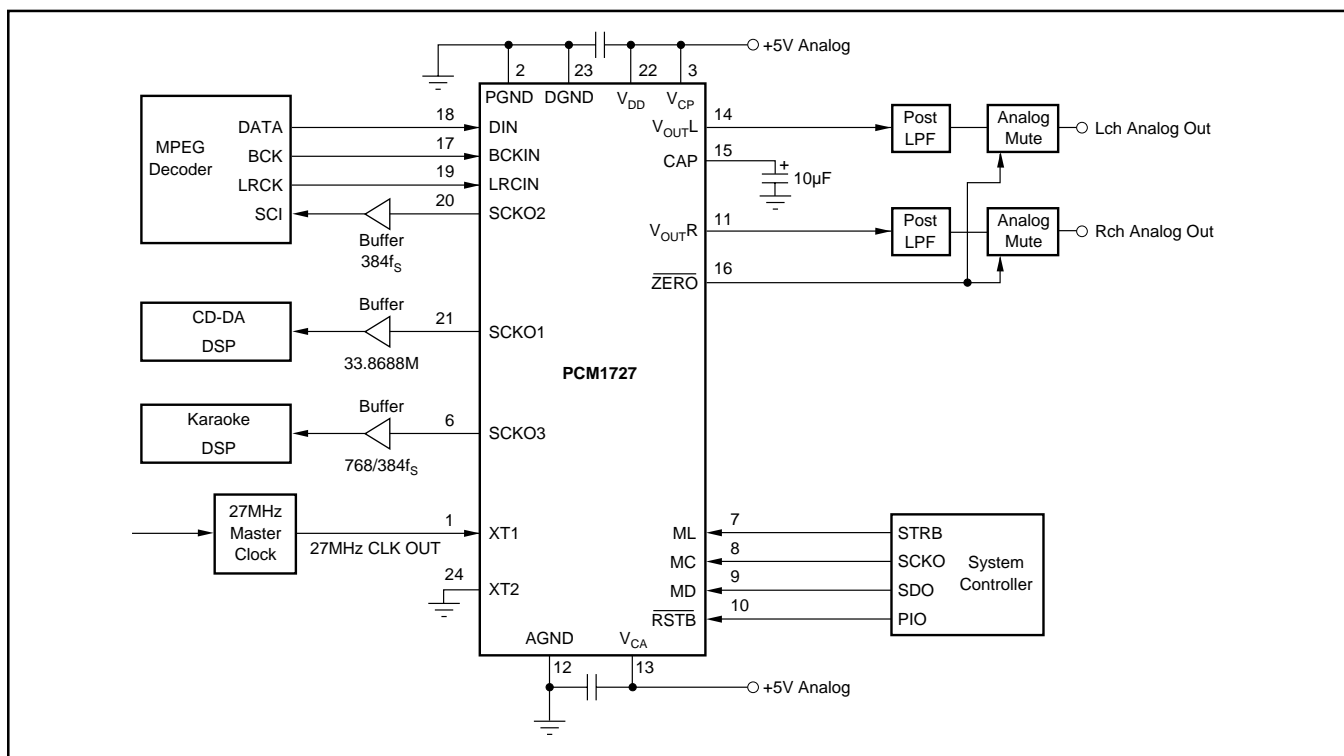

FIGURE 1. Connection Diagram for External Master Clock in a Typical MPEG2 Application.

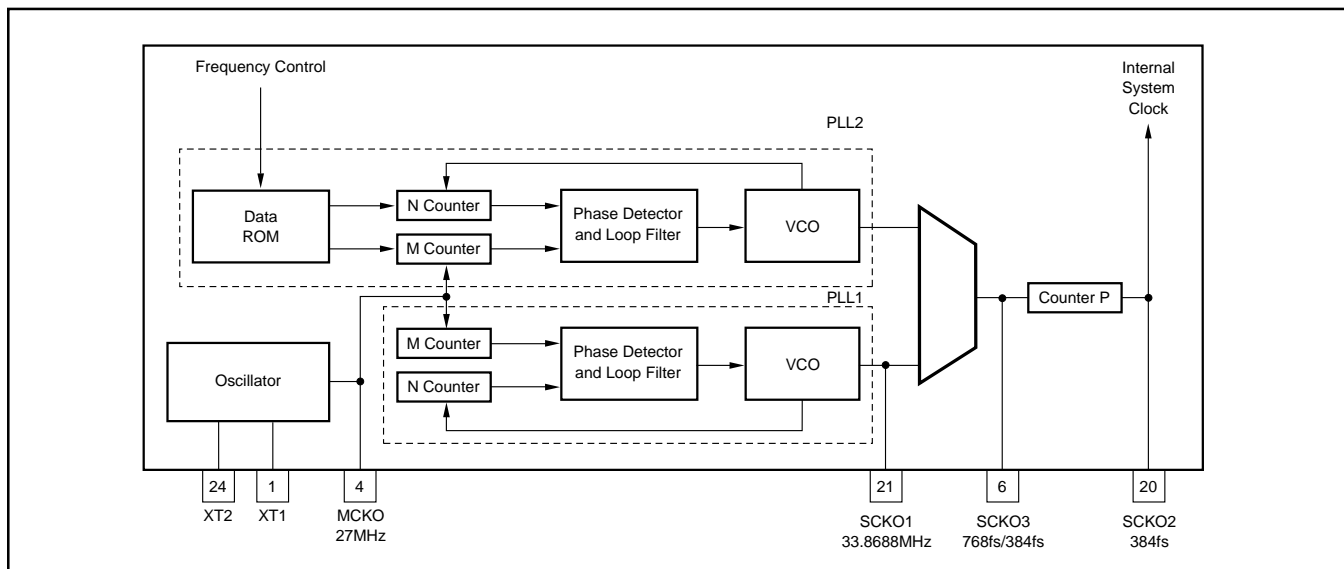

FIGURE 2. PLL Block Diagram.

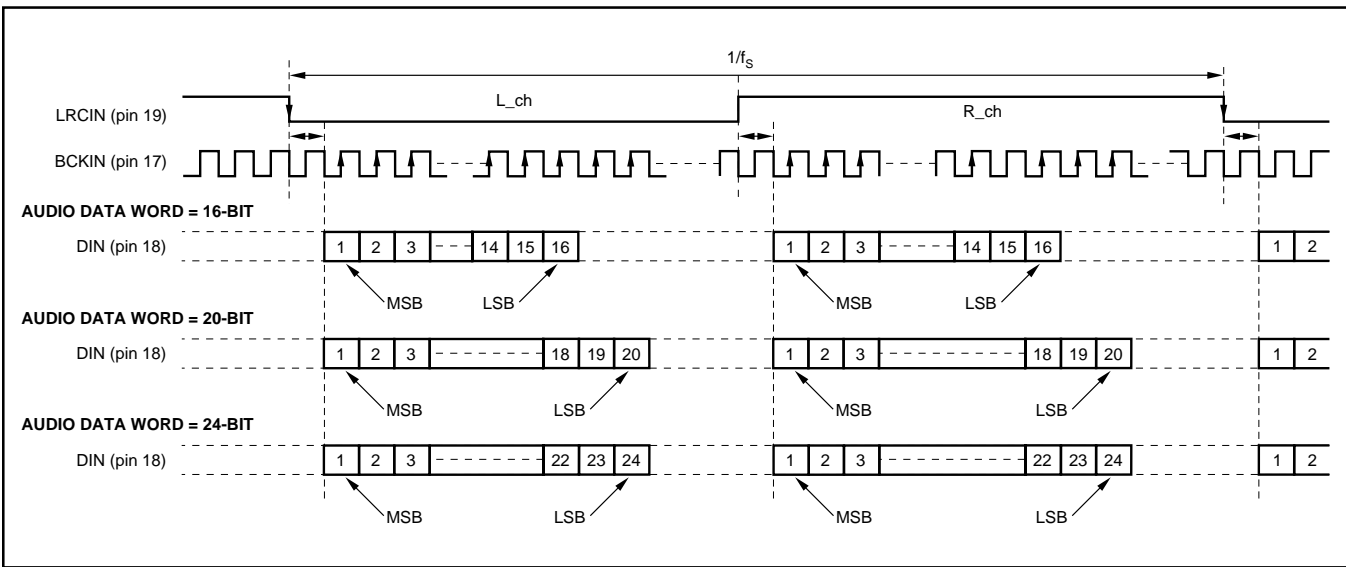

FIGURE 6. I²S Data Input Timing.

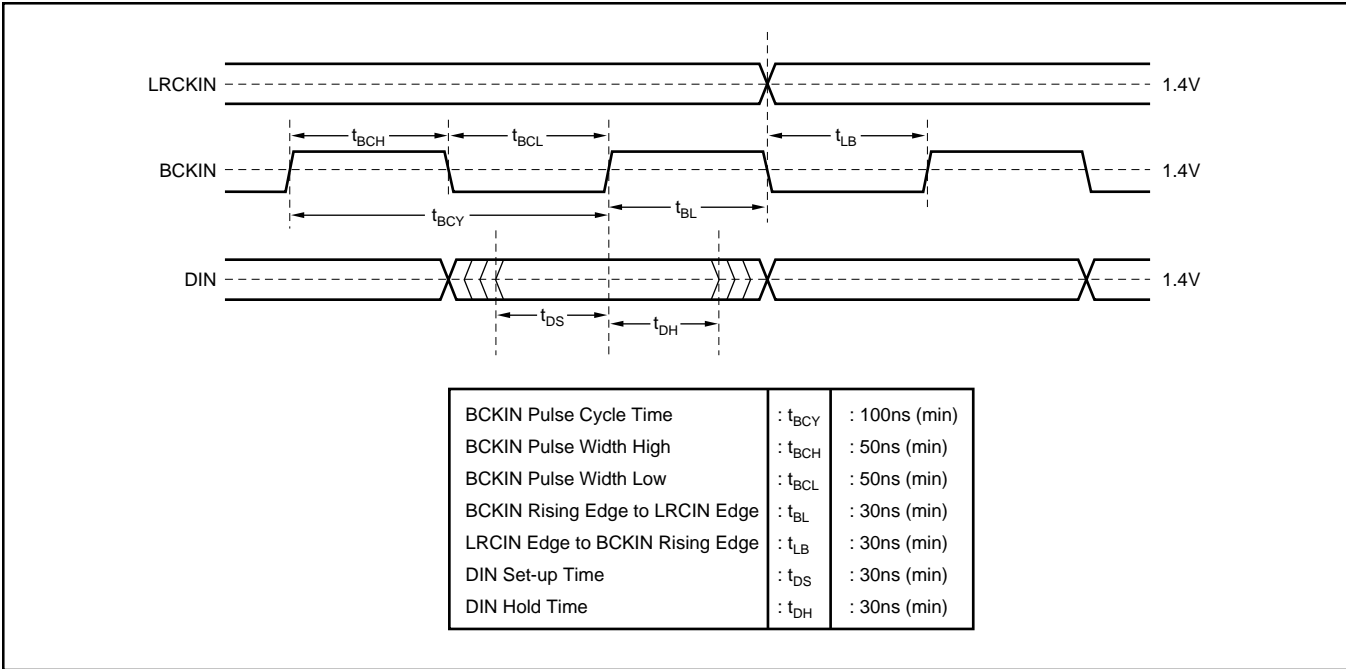

FIGURE 7. Audio Data Input Timing.

system clock is specified at 150ps typical. Figure 3 illustrates the timing requirements for the 27MHz master clock. Figure 4 illustrates the system clock connections for an external clock or crystal oscillator.

The PCM1727 internal PLL can be programmed for three different sampling frequencies (LRCIN), as shown in Table I. The internal sampling clocks generated by the various programmed frequencies are shown in Table II. The system clock output frequency for PCM1727 is 100% accurate.

To provide MCKO clock and SCKO1, SCKO2, SCKO3 clocks for external circuits, an external buffer may be used to avoid degrading audio performance (as shown in the connection diagram, in Figure 1).

	Sampling Frequencies-LRCIN (kHz)	
Standard Sampling Freq	44.1	48
Double of Standard Sampling Freq		96

TABLE I. Sampling Frequencies.

Sampling Frequency (LRCIN)		SCKO2 System Clock	SCKO3 System Clock
44.1kHz	Standard	16.9344MHz	33.8688MHz
48kHz	Standard	18.4320MHz	36.8640MHz
96kHz	Double	36.8640MHz	36.8640MHz

TABLE II. Sampling Frequencies vs Internal System Clock (= Output Frequencies of Dual PLL).

MAPPING OF PROGRAM REGISTERS

	B15	B14	B13	B12	B11	B10	B9	B8	B7	B6	B5	B4	B3	B2	B1	B0
MODE0	res	res	res	res	res	A1	A0	LDL	AL7	AL6	AL5	AL4	AL3	AL2	AL1	AL0
MODE1	res	res	res	res	res	A1	A0	LDR	AR7	AR6	AR5	AR4	AR3	AR2	AR1	AR0
MODE2	res	res	res	res	res	A1	A0	PL3	PL2	PL1	PL0	IW1	IW0	OPE	DEM	MUT
MODE3	res	res	res	res	res	A1	A0	IZD	SF1	SF0	DSR1	DSR0	res	ATC	LRP	I ² S

SPECIAL FUNCTIONS

The PCM1727 includes several special functions, including digital attenuation, digital de-emphasis, soft mute, data format selection and input word resolution. These functions are controlled using a three-wire interface. MD (pin 9) is used for the program data, MC (pin 8) is used to clock in the program data, and ML (pin 7) is used to latch in the program data. Table III lists the selectable special functions.

FUNCTION	DEFAULT MODE
Input Audio Data Format Selection Normal Format I ² S Format	Normal Format
Input Audio Data Bit Selection 16/20/24 Bits	16 Bits
Input LRCIN Polarity Selection Lch/Rch = High/Low Lch/Rch = Low/High	Lch/Rch = High/Low
De-emphasis Control	OFF
Soft Mute Control	OFF
Attenuation Control Lch, Rch Individually Lch, Rch Common	0dB Lch, Rch Individually Fixed
Infinite Zero Detection Circuit Control	OFF
Operation Enable (OPE)	Enabled
Sampling Rate Selection Standard Sampling Rate—44.1/48kHz Double Sampling Rate—96kHz Sampling Frequency 44.1kHz Group 48kHz Group	Standard Sampling Rate 44.1kHz
Analog Output Mode L, R, Mono, Mute	Stereo

TABLE III. Selectable Functions.

PROGRAM REGISTER BIT MAPPING

The PCM1727 special functions are controlled using four program registers which are 16 bits long. These registers are all loaded using MD. After the 16 data bits are clocked in, ML is used to latch in the data to the appropriate register. Table IV shows the complete mapping of the four registers and Figure 8 illustrates the serial interface timing.

REGISTER NAME	BIT NAME	DESCRIPTION
Register 0	AL (7:0) LDL A (1:0) res	DAC Attenuation Data for Lch Attenuation Data Load Control for Lch Register Address Reserved, should be "L"
Register 1	AR (7:0) LDL A (1:0) res	DAC Attenuation Data for Rch Attenuation Data Load Control for Rch Register Address Reserved, should be "L"
Register 2	MUT DEM OPE IW (1:0) PL (3:0) A (1:0) res	Left and Right DACs Soft Mute Control De-emphasis Control Left and Right DACs Operation Control Input Audio Data Bit Select Output Mode Select Register Address Reserved, should be "L"
Register 3	I ² S LRP ATC DSR (1:0) SF (1:0) IZD A (1:0) res	Audio Data Format Select Polarity of LRCIN (pin 19) Select Attenuator Control Double Sampling Rate Select Sampling Rate Select Infinite Zero Detection Circuit Control Register Address Reserved, should be "L"

TABLE IV. Internal Register Mapping.

REGISTER 0 (A1 = 0, A0 = 0)

B15	B14	B13	B12	B11	B10	B9	B8	B7	B6	B5	B4	B3	B2	B1	B0
res	res	res	res	res	A1	A0	LDL	AL7	AL6	AL5	AL4	AL3	AL2	AL1	AL0

Register 0 is used to control left channel attenuation. Bits 0 - 7 (AL0 - AL7) are used to determine the attenuation level. The level of attenuation is given by:

$$ATT = [20 \log_{10} (ATT_DATA/255)] \text{ dB}$$

ATTENUATION DATA LOAD CONTROL

Bit 8 (LDL) is used to control the loading of attenuation data in B0:B7. When LDL is set to 0, attenuation data will be loaded into AL0:AL7, but it will not affect the attenuation level until LDL is set to 1. LDR in Register 1 has the same function for right channel attenuation.

Attenuation Level (ATT) can be controlled as following Resistor set AL (R) (7:0).

AL (R) (7:0)	ATT LEVEL
00h	-∞dB (Mute)
01h	-48.16dB
.	.
.	.
.	.
FEh	-0.07dB
FFh	0dB

REGISTER 1 (A1 = 0, A0 = 1)

B15	B14	B13	B12	B11	B10	B9	B8	B7	B6	B5	B4	B3	B2	B1	B0
res	res	res	res	res	A1	A0	LDR	AR7	AR6	AR5	AR4	AR3	AR2	AR1	AR0

Register 1 is used to control right channel attenuation. As in Register 1, bits 0 - 7 (AR0 - AR7) control the level of attenuation.

REGISTER 2 (A1 = 1, A0 = 0)

B15	B14	B13	B12	B11	B10	B9	B8	B7	B6	B5	B4	B3	B2	B1	B0
res	res	res	res	res	A1	A0	PL3	PL2	PL1	PL0	IW1	IW0	OPE	DEM	MUTE

Register 2 is used to control soft mute, de-emphasis, operation enable, input resolution, and output format. Bit 0 is used for soft mute: a HIGH level on bit 0 will cause the output to be muted (this is ramped down in the digital domain, so no *click* is audible). Bit 1 is used to control de-emphasis. A LOW level on bit 1 disables de-emphasis, while a HIGH level enables de-emphasis.

Bit 2, (OPE) is used for operational control. Table V illustrates the features controlled by OPE.

	DATA INPUT	DAC OUTPUT	SOFTWARE MODE INPUT
OPE = 1	Zero	Forced to BPZ ⁽¹⁾	Enabled
	Other	Forced to BPZ ⁽¹⁾	Enabled
OPE = 0	Zero	Controlled by IZD	Enabled
	Other	Normal	Enabled

TABLE V. Operation Enable (OPE) Function.

OPE controls the operation of the DAC: when OPE is LOW, the DAC will convert all non-zero input data. If the input data is continuously zero for 65, 536 cycles of BCKIN, the output will be forced to zero only if IZD is HIGH. When OPE is HIGH, the output of the DAC will be forced to bipolar zero, irrespective of any input data.

	DATA INPUT	DAC OUTPUT
IZD = 1	Zero	Forced to BPZ ⁽¹⁾
	Other	Normal
IZD = 0	Zero	Zero ⁽²⁾
	Other	Normal

TABLE VI. Infinite Zero Detection (IZD) Function.

	DATA INPUT	DAC OUTPUT	SOFTWARE MODE INPUT
RSTB = HIGH	Zero	Controlled by OPE and IZD	Enabled
	Other	Controlled by OPE and IZD	Enabled
RSTB = LOW	Zero	Forced to BPZ ⁽¹⁾	Disabled
	Other	Forced to BPZ ⁽¹⁾	Disabled

TABLE VII. Reset (RSTB) Function.

NOTE: (1) ΔΣ is disconnected from output amplifier. (2) ΔΣ is connected to output amplifier.

Bits 3 (IW0) and 4 (IW1) are used to determine input word resolution. PCM1727 can be set up for input word resolutions of 16, 20, or 24 bits:

Bit 4 (IW1)	Bit 3 (IW0)	Input Resolution
0	0	16-bit Data Word
0	1	20-bit Data Word
1	0	24-bit Data Word
1	1	Reserved

Bits 5, 6, 7, and 8 (PL0:3) are used to control output format. The output of PCM1727 can be programmed for 16 different states, as shown in Table VIII.

PL0	PL1	PL2	PL3	Lch OUTPUT	Rch OUTPUT	NOTE
0	0	0	0	MUTE	MUTE	MUTE
0	0	0	1	MUTE	R	
0	0	1	0	MUTE	L	
0	0	1	1	MUTE	(L + R)/2	
0	1	0	0	R	MUTE	
0	1	0	1	R	R	
0	1	1	0	R	L	REVERSE
0	1	1	1	R	(L + R)/2	
1	0	0	0	L	MUTE	
1	0	0	1	L	R	STEREO
1	0	1	0	L	L	
1	0	1	1	L	(L + R)/2	
1	1	0	0	(L + R)/2	MUTE	
1	1	0	1	(L + R)/2	R	
1	1	1	0	(L + R)/2	L	
1	1	1	1	(L + R)/2	(L + R)/2	MONO

TABLE VIII. Programmable Output Format.

REGISTER 3 (A1 = 1, A0 = 1)

B15	B14	B13	B12	B11	B10	B9	B8	B7	B6	B5	B4	B3	B2	B1	B0
res	res	res	res	res	A1	A0	IZD	SF1	SF0	DSR1	DSR0	res	ATC	LRP	I ² S

Register 3 is used to control input data format and polarity, attenuation channel control, system clock frequency, sampling frequency and infinite zero detection.

Bits 0 (I²S) and 1 (LRP) are used to control the input data format. A LOW on bit 0 sets the format to *Normal* (MSB-first, right-justified Japanese format) and a HIGH sets the format to I²S (Philips serial data protocol). Bit 1 (LRP) is used to select the polarity of LRCIN (sample rate clock). When bit 1 is LOW, left channel data are assumed when

LRCIN is in a HIGH phase and right channel data are assumed when LRCIN is in a LOW phase. When bit 1 is HIGH, the polarity assumption is reversed.

Bit 2 (ATC) is used for controlling the attenuator. When bit 2 is HIGH, the attenuation data loaded in program Register 0 are used for both left and right channels. When bit 2 is LOW, the attenuation data for each register are applied separately to left and right channels.

Bits 4 (DSR0) and 5 (DSR1) are used to control multiples of the sampling rate:

DSR1	DSR0	Multiple	
0	0	Normal	44.1/48kHz
0	1	Double	96kHz
1	0	Reserved	Reserved
1	1	Reserved	Reserved

Bits 6 (SF0) and 7 (SF1) are used to select the sampling frequency. Frequency selection must be made with an interval time greater than 20µs.

SF1	SF0	Sampling Frequency	
0	0	44.1kHz group	44.1kHz
0	1	48kHz group	48/96kHz
1	0	Reserved	Reserved
1	1	Reserved	Reserved

Bit 8 is used to control the infinite zero detection function (IZD).

When IZD is LOW, the zero detect circuit is off. Under this condition, no automatic muting will occur if the input is continuously zero. When IZD is HIGH, the zero detect feature is enabled. If the input data is continuously zero for 65, 536 cycles of BCKIN, the output will be immediately forced to a bipolar zero state ($V_{CC}/2$). The zero detection feature is used to avoid noise which may occur when the input is DC. When the output is forced to bipolar zero, there may be an audible click. PCM1727 allows the zero detect feature to be disabled so the user can implement an external muting circuit.

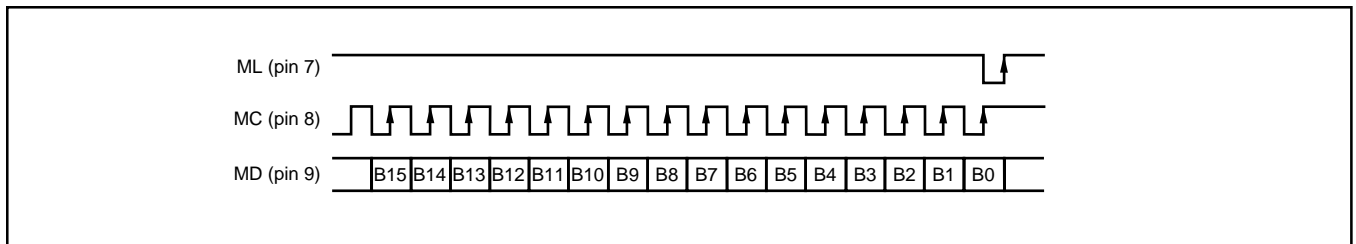

FIGURE 8. Three-Wire Serial Interface.

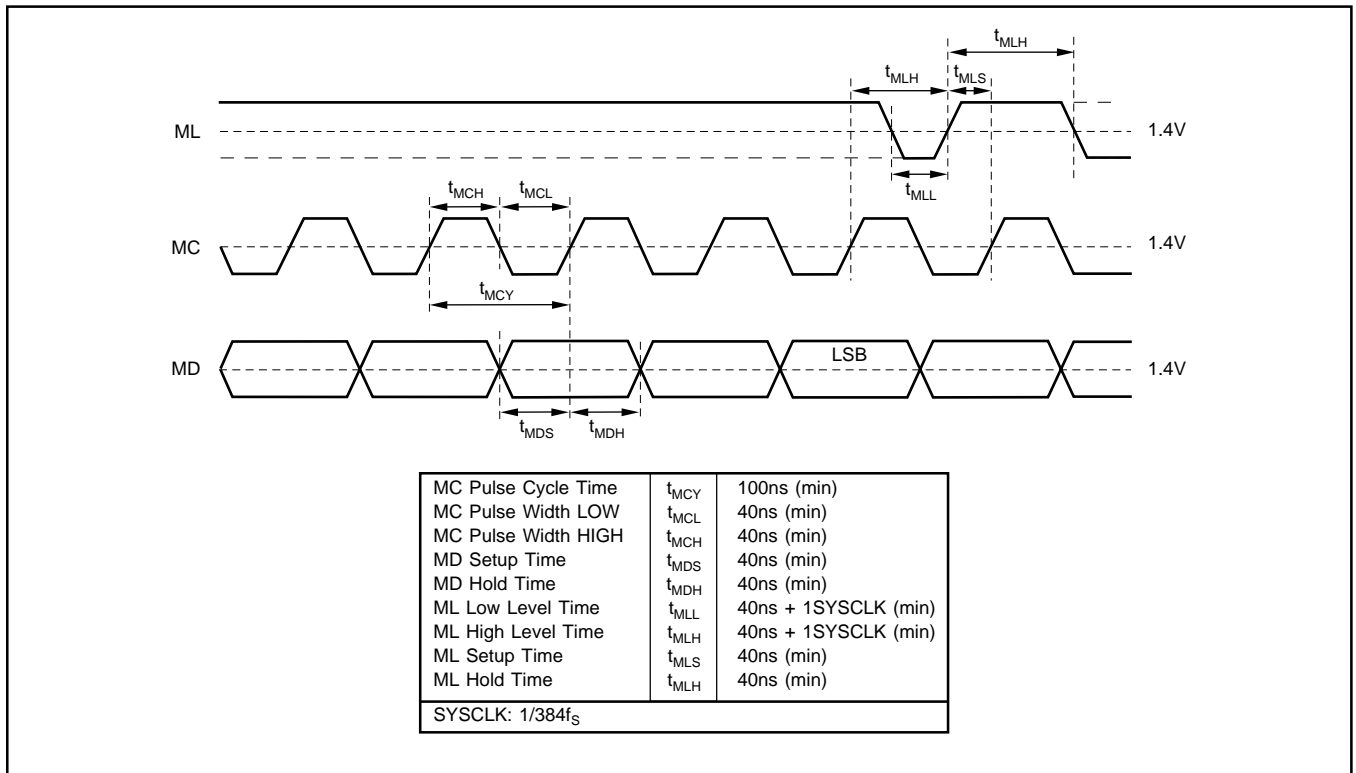

FIGURE 9. Program Register Input Timing.

APPLICATION CONSIDERATIONS

DELAY TIME

There is a finite delay time in delta-sigma converters. In analog-to-digital converters, this is commonly referred to as latency. For a delta-sigma DAC, delay time is determined by the order number of the FIR filter stage, and the chosen sampling rate. The following equation expresses the delay time of the PCM1727:

$$t_D = 11.125 \times 1/f_S$$

For $f_S = 44.1\text{kHz}$, $t_D = 11.125/44.1\text{kHz} = 251.4\mu\text{s}$

Applications using data from a disc or tape source, such as CD audio, DVD audio, Video CD, DAT, Minidisc, etc., generally are not affected by delay time.

OUTPUT FILTERING

For testing purposes, all dynamic tests are done on the PCM1727 using a 20kHz low-pass filter. This filter limits the measured bandwidth for THD+N, etc. to 20kHz. Failure to use such a filter will result in higher THD+N and lower SNR and Dynamic Range readings than are found in the specifications. The low-pass filter removes out-of-band noise. Although not audible, it may affect dynamic specification numbers.

The performance of the internal low-pass filter from DC to 24kHz is shown in Figure 10. The higher frequency rolloff of the filter is shown in Figure 11. If an application has the PCM1727 driving a wideband amplifier, it is recommended to use an external low-pass filter. A simple 3rd-order filter is shown in Figure 12. For some applications, a passive RC filter or 2nd-order filter may be adequate.

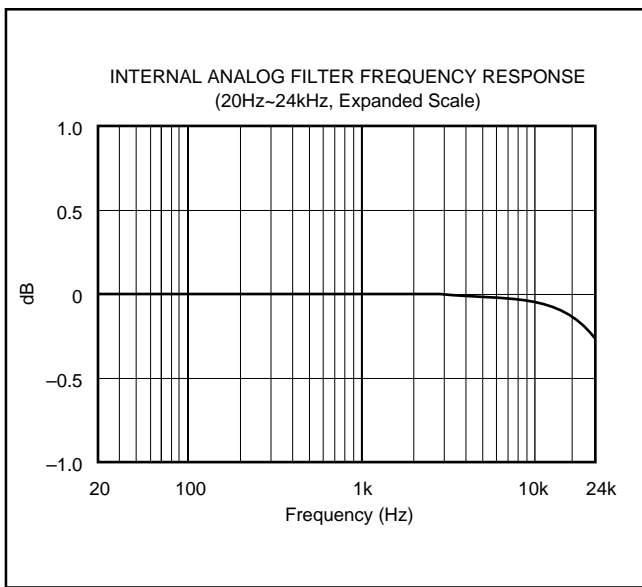

FIGURE 10. Low-Pass Filter Frequency Response.

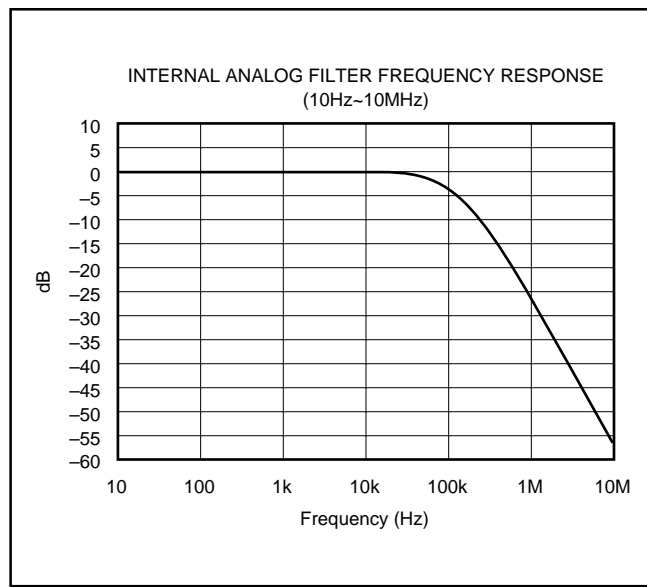

FIGURE 11. Low-Pass Filter Wideband Frequency Response.

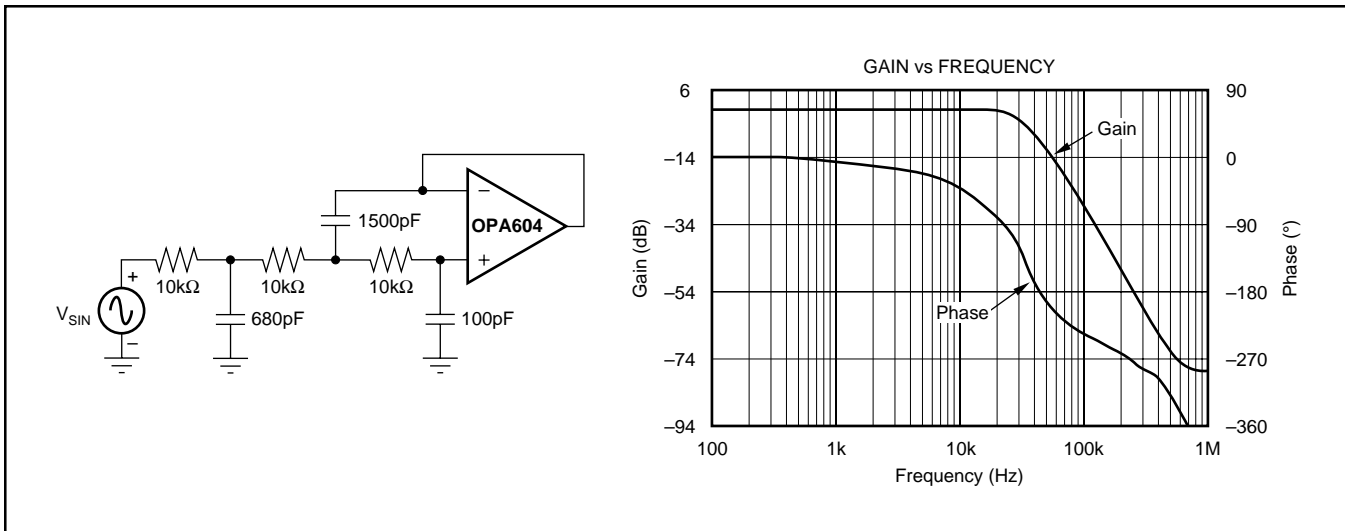

FIGURE 12. 3rd-Order Low-Pass Filter.

Reset

The PCM1727 has both an internal power-on reset circuit and the $\overline{\text{RSTB}}$ pin (pin 10) which accepts an external forced reset by $\overline{\text{RSTB}} = \text{LOW}$. For internal power-on reset, initialize (reset) is done automatically at power on $V_{\text{DD}} > 2.2\text{V}$ (typ). During internal reset = LOW, the output of the DAC is invalid and the analog outputs are forced to $V_{\text{CC}}/2$. Figure 13 illustrates the timing of the internal power-on reset.

The PCM1727 accepts an external forced reset when $\overline{\text{RSTB}} = \text{L}$. When $\overline{\text{RSTB}} = \text{L}$, the output of the DAC is invalid and the analog outputs are forced to $V_{\text{CC}}/2$ after internal initialization (1024 system clocks count after $\overline{\text{RSTB}} = \text{H}$.) Figure 14 illustrates the timing of the $\overline{\text{RSTB}}$ reset pin.

For system applications, the power-up time of the internal PLL circuit to provide a stable system clock output, is approximately 1024 system clocks plus a 15ms transient time.

POWER SUPPLY CONNECTIONS

The PCM1727 has three power supply connections: digital (V_{DD}), analog (V_{CA}), and PLL (V_{CP}). Each connection also has a separate ground return pin. It is acceptable to use a

common +5V power supply for all three power pins. If separate supplies are used without a common connection, the delta between the supplies during ramp-up time must be less than 0.3V. An application circuit to avoid a power-on latch-up condition is shown in Figure 15.

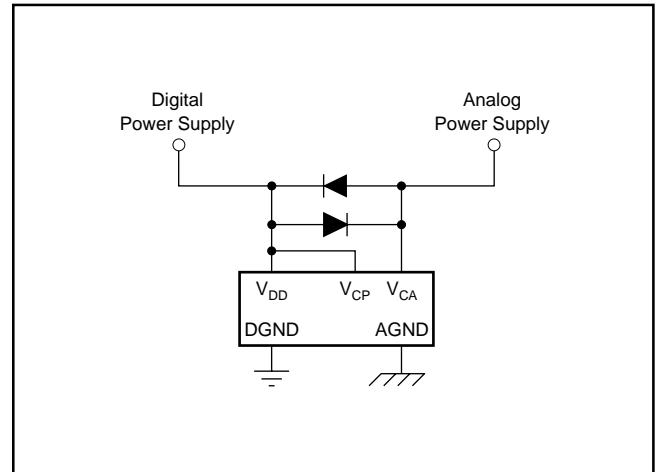

FIGURE 15. Latch-up Prevention Circuit.

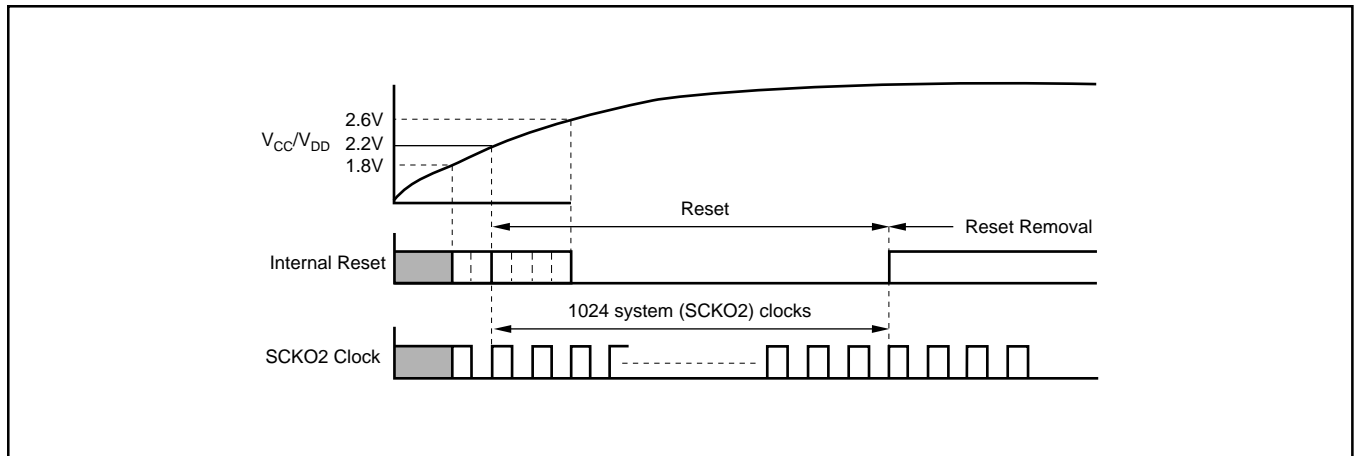

FIGURE 13. Internal Power-On Reset Timing.

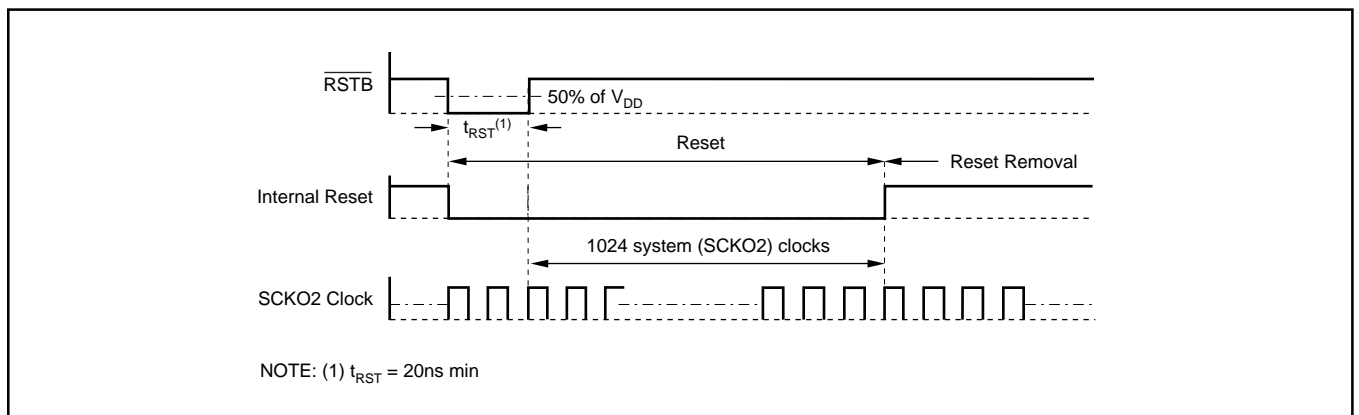

FIGURE 14. $\overline{\text{RSTB}}$ -Pin Reset Timing.

BYPASSING POWER SUPPLIES

The power supplies should be bypassed as close as possible to the unit. Refer to Figure 18 for optimal values of bypass capacitors. It is also recommended to include a 0.1 μ F ceramic capacitor in parallel with the 10 μ F tantalum capacitor.

THEORY OF OPERATION

The delta-sigma section of the PCM1727 is based on a 5-level amplitude quantizer and a 3rd-order noise shaper. This section converts the oversampled input data to 5-level delta-sigma format.

A block diagram of the 5-level delta-sigma modulator is shown in Figure 16. This 5-level delta-sigma modulator has the advantage of stability and clock jitter sensitivity over the typical one-bit (2 level) delta-sigma modulator.

The combined oversampling rate of the delta-sigma modulator and the internal 8X interpolation filter is $48f_s$ for a $384f_s$ system clock. The theoretical quantization noise performance of the 5-level delta-sigma modulator is shown in Figure 17.

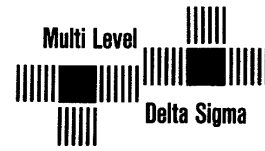

AC-3 APPLICATION CIRCUIT

A typical application for the PCM1727 is AC-3 5.1 channel audio decoding and playback. This circuit uses the PCM1727 to develop the audio system clock from the 27MHz video clock, with the SCKO2 pin used to drive the AC-3 decoder and two PCM1720 units, the non-PLL version of the PCM1723 and PCM1727.

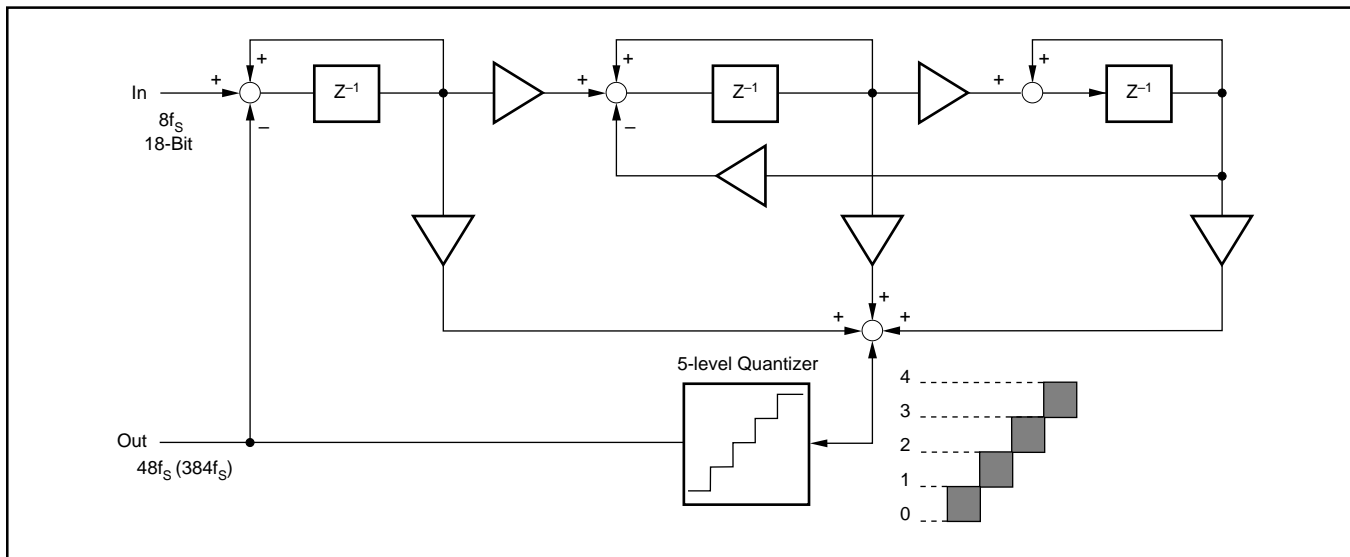

FIGURE 16. 5-Level $\Delta\Sigma$ Modulator Block Diagram.

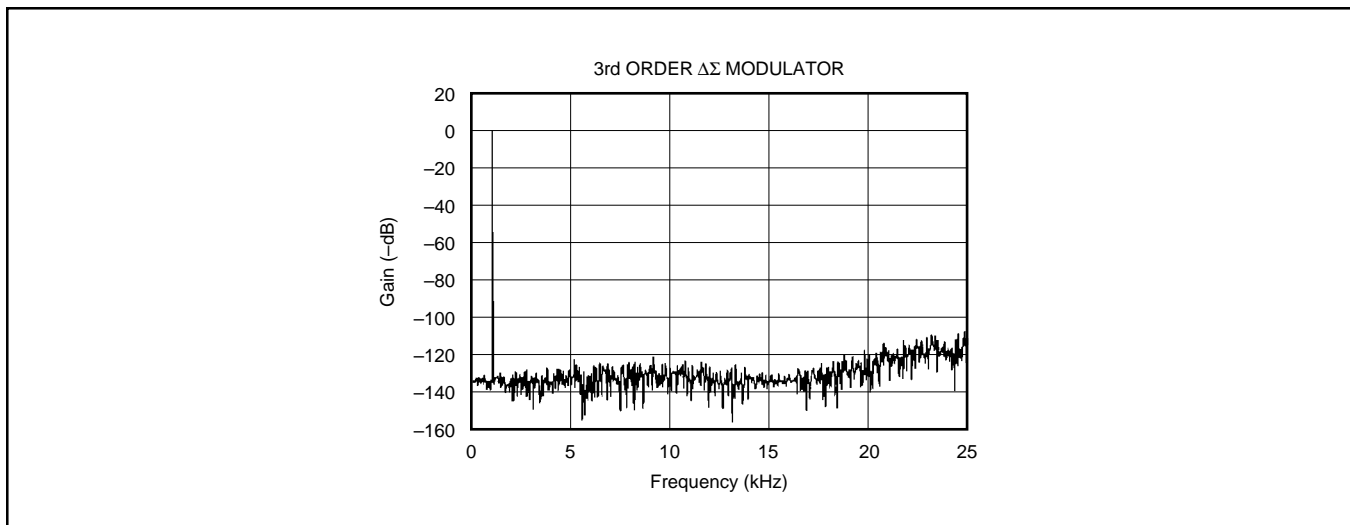

FIGURE 17. Quantization Noise Spectrum.

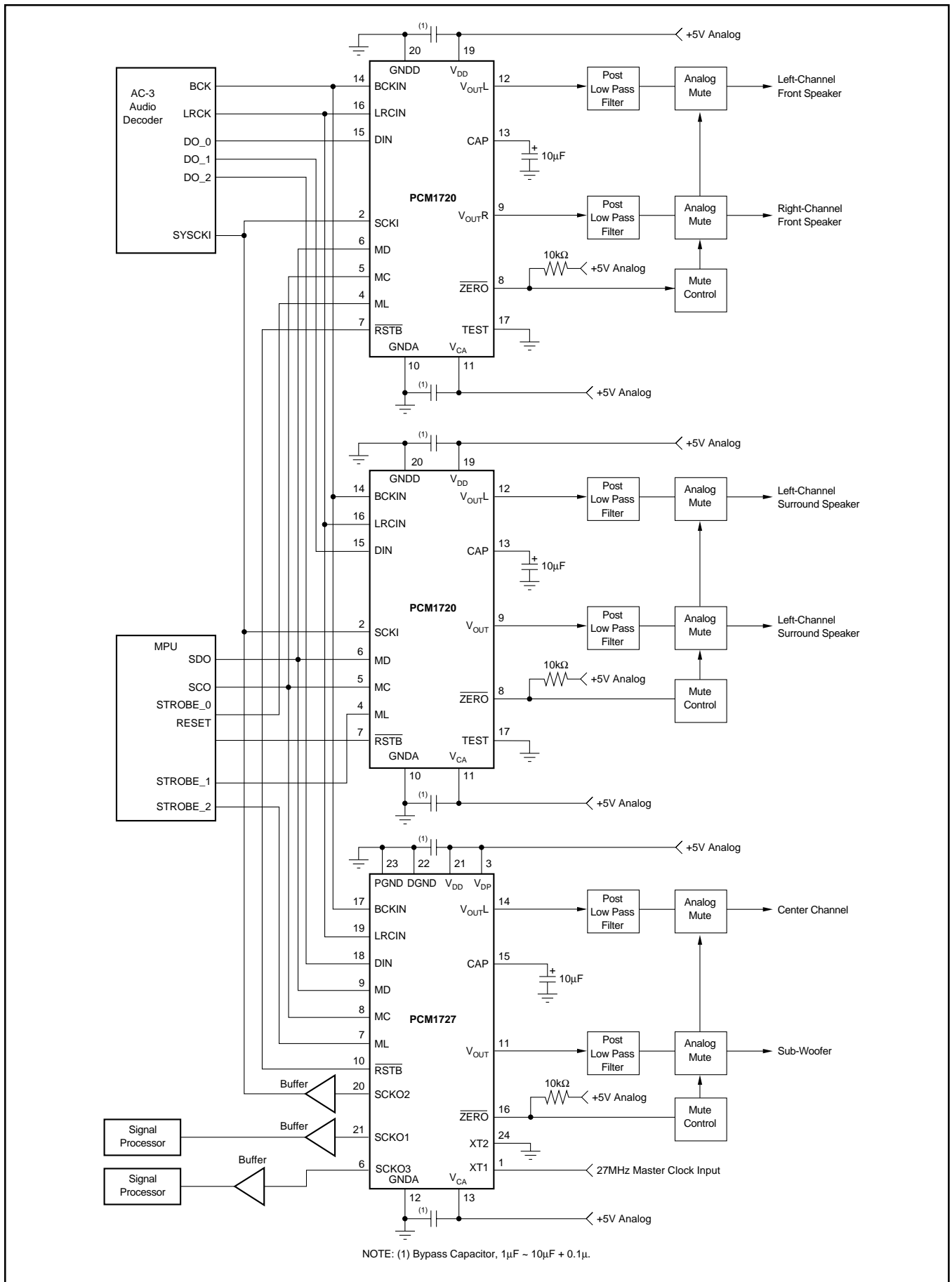

FIGURE 18. Connection Diagram for a 6-Channel AC-3 Application.

Revision History

DATE	REVISION	PAGE	SECTION	DESCRIPTION
5/07	A	—	Entire Document	Updated format and added overbars to RSTB and ZERO.
		2	Electrical Characteristics	Added "Selectable" to <i>Audio Data Interface Format</i> typical value column.
				Deleted "Selectable" from <i>Audio Data Format</i> unit column.
		6	Dual PLL Circuit	Changed "XT2 should be connected" to "XT2 must be connected."
				Added sentence regarding XT1 signal amplitude and C1, C2 determination.
		7	Figure 3	Changed 2.0V/0.8V to 1.2V/0.4V.
		8	Dual PLL Circuit	Deleted paragraph regarding frequency error.
		10	Register 3	Changed B3 from "YES" to "res" (typo).
11	Register 3	Added sentence to Bit 6 regarding interval time must be greater than 20 μ s.		
15	Figure 18	Changed Figure 18.		

NOTE: Page numbers for previous revisions may differ from page numbers in the current version.

PACKAGING INFORMATION

Orderable Device	Status ⁽¹⁾	Package Type	Package Drawing	Pins	Package Qty	Eco Plan ⁽²⁾	Lead/Ball Finish	MSL Peak Temp ⁽³⁾
PCM1727E	ACTIVE	SSOP	DB	24	58	Green (RoHS & no Sb/Br)	CU NIPDAU	Level-1-260C-UNLIM
PCM1727EG4	ACTIVE	SSOP	DB	24	58	Green (RoHS & no Sb/Br)	CU NIPDAU	Level-1-260C-UNLIM

⁽¹⁾ The marketing status values are defined as follows:

ACTIVE: Product device recommended for new designs.

LIFEBUY: TI has announced that the device will be discontinued, and a lifetime-buy period is in effect.

NRND: Not recommended for new designs. Device is in production to support existing customers, but TI does not recommend using this part in a new design.

PREVIEW: Device has been announced but is not in production. Samples may or may not be available.

OBsolete: TI has discontinued the production of the device.

⁽²⁾ Eco Plan - The planned eco-friendly classification: Pb-Free (RoHS), Pb-Free (RoHS Exempt), or Green (RoHS & no Sb/Br) - please check <http://www.ti.com/productcontent> for the latest availability information and additional product content details.

TBD: The Pb-Free/Green conversion plan has not been defined.

Pb-Free (RoHS): TI's terms "Lead-Free" or "Pb-Free" mean semiconductor products that are compatible with the current RoHS requirements for all 6 substances, including the requirement that lead not exceed 0.1% by weight in homogeneous materials. Where designed to be soldered at high temperatures, TI Pb-Free products are suitable for use in specified lead-free processes.

Pb-Free (RoHS Exempt): This component has a RoHS exemption for either 1) lead-based flip-chip solder bumps used between the die and package, or 2) lead-based die adhesive used between the die and leadframe. The component is otherwise considered Pb-Free (RoHS compatible) as defined above.

Green (RoHS & no Sb/Br): TI defines "Green" to mean Pb-Free (RoHS compatible), and free of Bromine (Br) and Antimony (Sb) based flame retardants (Br or Sb do not exceed 0.1% by weight in homogeneous material)

⁽³⁾ MSL, Peak Temp. -- The Moisture Sensitivity Level rating according to the JEDEC industry standard classifications, and peak solder temperature.

Important Information and Disclaimer:The information provided on this page represents TI's knowledge and belief as of the date that it is provided. TI bases its knowledge and belief on information provided by third parties, and makes no representation or warranty as to the accuracy of such information. Efforts are underway to better integrate information from third parties. TI has taken and continues to take reasonable steps to provide representative and accurate information but may not have conducted destructive testing or chemical analysis on incoming materials and chemicals. TI and TI suppliers consider certain information to be proprietary, and thus CAS numbers and other limited information may not be available for release.

In no event shall TI's liability arising out of such information exceed the total purchase price of the TI part(s) at issue in this document sold by TI to Customer on an annual basis.

DB (R-PDSO-G**)

PLASTIC SMALL-OUTLINE

28 PINS SHOWN



- NOTES: A. All linear dimensions are in millimeters.
 B. This drawing is subject to change without notice.
 C. Body dimensions do not include mold flash or protrusion not to exceed 0,15.
 D. Falls within JEDEC MO-150

IMPORTANT NOTICE

Texas Instruments Incorporated and its subsidiaries (TI) reserve the right to make corrections, modifications, enhancements, improvements, and other changes to its products and services at any time and to discontinue any product or service without notice. Customers should obtain the latest relevant information before placing orders and should verify that such information is current and complete. All products are sold subject to TI's terms and conditions of sale supplied at the time of order acknowledgment.

TI warrants performance of its hardware products to the specifications applicable at the time of sale in accordance with TI's standard warranty. Testing and other quality control techniques are used to the extent TI deems necessary to support this warranty. Except where mandated by government requirements, testing of all parameters of each product is not necessarily performed.

TI assumes no liability for applications assistance or customer product design. Customers are responsible for their products and applications using TI components. To minimize the risks associated with customer products and applications, customers should provide adequate design and operating safeguards.

TI does not warrant or represent that any license, either express or implied, is granted under any TI patent right, copyright, mask work right, or other TI intellectual property right relating to any combination, machine, or process in which TI products or services are used. Information published by TI regarding third-party products or services does not constitute a license from TI to use such products or services or a warranty or endorsement thereof. Use of such information may require a license from a third party under the patents or other intellectual property of the third party, or a license from TI under the patents or other intellectual property of TI.

Reproduction of TI information in TI data books or data sheets is permissible only if reproduction is without alteration and is accompanied by all associated warranties, conditions, limitations, and notices. Reproduction of this information with alteration is an unfair and deceptive business practice. TI is not responsible or liable for such altered documentation. Information of third parties may be subject to additional restrictions.

Resale of TI products or services with statements different from or beyond the parameters stated by TI for that product or service voids all express and any implied warranties for the associated TI product or service and is an unfair and deceptive business practice. TI is not responsible or liable for any such statements.

TI products are not authorized for use in safety-critical applications (such as life support) where a failure of the TI product would reasonably be expected to cause severe personal injury or death, unless officers of the parties have executed an agreement specifically governing such use. Buyers represent that they have all necessary expertise in the safety and regulatory ramifications of their applications, and acknowledge and agree that they are solely responsible for all legal, regulatory and safety-related requirements concerning their products and any use of TI products in such safety-critical applications, notwithstanding any applications-related information or support that may be provided by TI. Further, Buyers must fully indemnify TI and its representatives against any damages arising out of the use of TI products in such safety-critical applications.

TI products are neither designed nor intended for use in military/aerospace applications or environments unless the TI products are specifically designated by TI as military-grade or "enhanced plastic." Only products designated by TI as military-grade meet military specifications. Buyers acknowledge and agree that any such use of TI products which TI has not designated as military-grade is solely at the Buyer's risk, and that they are solely responsible for compliance with all legal and regulatory requirements in connection with such use.

TI products are neither designed nor intended for use in automotive applications or environments unless the specific TI products are designated by TI as compliant with ISO/TS 16949 requirements. Buyers acknowledge and agree that, if they use any non-designated products in automotive applications, TI will not be responsible for any failure to meet such requirements.

Following are URLs where you can obtain information on other Texas Instruments products and application solutions:

Products

Amplifiers	amplifier.ti.com
Data Converters	dataconverter.ti.com
DLP® Products	www.dlp.com
DSP	dsp.ti.com
Clocks and Timers	www.ti.com/clocks
Interface	interface.ti.com
Logic	logic.ti.com
Power Mgmt	power.ti.com
Microcontrollers	microcontroller.ti.com
RFID	www.ti-rfid.com
RF/IF and ZigBee® Solutions	www.ti.com/lprf

Applications

Audio	www.ti.com/audio
Automotive	www.ti.com/automotive
Broadband	www.ti.com/broadband
Digital Control	www.ti.com/digitalcontrol
Medical	www.ti.com/medical
Military	www.ti.com/military
Optical Networking	www.ti.com/opticalnetwork
Security	www.ti.com/security
Telephony	www.ti.com/telephony
Video & Imaging	www.ti.com/video
Wireless	www.ti.com/wireless

Mailing Address: Texas Instruments, Post Office Box 655303, Dallas, Texas 75265
Copyright © 2009, Texas Instruments Incorporated