

Features

- 18V to 36V Input Range
- -40° to +100°C Operating Temp
- 1500 VDC Isolation
- 88.5% Efficiency
- Programmable Output Voltage 6.5V to 17.5V
- Remote On/Off
- Differential Remote Sense
- N+1 Current Sharing
- Over-Current Protection
- Over-Temperature Protection
- Over-Voltage Protection
- Solderable Copper Case

Description

The PT4475 Excalibur™ module combines state-of-the-art power conversion technology with un-paralleled flexibility. Operating off a standard 24V telecom input, the PT4475 provides a full 100W output at load currents up to 8.5A, and over the programmable output voltage range of 6.5V to 17.5V.

The PT4475 features high efficiency, ultra-fast transient response, and the capability for true N+1 current sharing. This product also includes output short circuit and over-temperature protection.

Standard Application

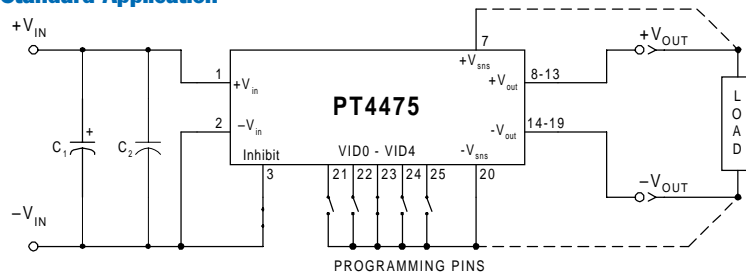

- C₁ = Optional 33µF, 100V electrolytic capacitor
- C₂ = Optional 1µF, 100V ceramic capacitor
- Programming pins, VID0-VID4, are shown configured for V_o =12.0V
- For normal operation, pin 3 (Inhibit) must be connected to -V_{in}.
- For operation in N+1 configuration, consult the related application note.
- Pins 6 & 26 are used for N+1 configurations only.

Specifications

Characteristics (T _a =25°C unless noted)	Symbols	Conditions (V _{in} =24V, V _o =12.0V unless noted)	PT4475			
			Min	Typ	Max	Units
Output Current	I _o	Over V _{in} range (100W max)	0.1	—	8.5 (1)	A
Current Limit	I _{cl}	V _{in} = 18V	—	10	—	A
Current Sharing		Single line referenced to -V _{sense}	—	—	±10	%
Input Voltage Range	V _{in}	I _o = 0 to I _o max	18	24	36	V
Output Voltage Tolerance	ΔV _o	Over V _{in} range, I _o = I _o max T _a = -40 to +100°C case	—	±1.0	±2.0	%V _o
Line Regulation	Reg _{line}	Over V _{in} range @ max I _o	—	±0.1	±1.0	%V _o
Load Regulation	Reg _{load}	0 to 100% of I _o max	—	±0.5	±1.0	%V _o
V _o Ripple/Noise	V _n	I _o = I _o max	—	120	150	mV _{pp}
Transient Response	t _{tr}	50% to 75% I _o max @ 0.1A/µs V _o over/undershoot (no ext caps)	—	N/A	—	µSec
		50% to 100% I _o max @ 1.0A/µs V _o over/undershoot (no ext. caps)	—	1.0	—	%V _o
V _o Rise Time	V _{otr}	At turn-on	—	—	10	mSec
Efficiency	η	I _o = 5A	—	89	—	%
Switching Frequency	f _o	—	—	300	—	kHz
Remote On/Off	Off On	referenced to -V _{in}	+2.5 -0.5	—	+75.0 +0.8	VDC
Over-Voltage Protection	OVP	Shutdown and latch off	—	125	—	%V _o
Isolation	—	—	1500	—	—	VDC
Operating Temperature Range	T _c	Measured at center of case	-40	—	+100	°C
Over-Temperature Shutdown	OTP	Case temperature - Auto reset	—	+110	—	°C
Storage Temperature	T _s	—	-40	—	+125	°C
Reliability	MTBF	Per Bellcore TR-332 50% stress, t = 40°C, ground benign	1.7	—	—	10 ⁶ Hrs
Mechanical Shock	—	Per Mil-STD-883D, Method 2002.3, 1mS, Half-sine, mounted to a fixture	—	500	—	G's
Mechanical Vibration (Mil-STD-883D, 20-2000Hz)	—	Vertical (Suffix N)	—	10 (2)	—	G's
		Horizontal (Suffixes A, C)	—	20 (2)	—	G's
Weight	—	—	—	90	—	grams

Notes: (1) The maximum output current is limited to 8.5A or 100/V_{OUT}, whichever is less.
 (2) Only the case pins on the through-hole package types (suffixes N & A) must be soldered. For more information see the applicable package outline drawing.

PT4475—24V

100-W 8.5-A Programmable Isolated DC/DC Converter

Pin-Out Information

Pin	Function	Pin	Function
1	+V _{in}	14	-V _{out}
2	-V _{in}	15	-V _{out}
3	Inhibit	16	-V _{out}
4	Do not connect	17	-V _{out}
5	Do not connect	18	-V _{out}
6	Sync	19	-V _{out}
7	+V _{sense}	20	-V _{sense}
8	+V _{out}	21	VID0
9	+V _{out}	22	VID1
10	+V _{out}	23	VID2
11	+V _{out}	24	VID3
12	+V _{out}	25	VID4
13	+V _{out}	26	Share

Programming Information

VID3	VID2	VID1	VID0	VID4=1 V _{out}	VID4=0 V _{out}
1	1	1	1	10.0	6.5
1	1	1	0	10.5	6.75
1	1	0	1	11.0	7.0
1	1	0	0	11.5	7.25
1	0	1	1	12.0	7.5
1	0	1	0	12.5	7.75
1	0	0	1	13.0	8.0
1	0	0	0	13.5	8.25
0	1	1	1	14.0	8.5
0	1	1	0	14.5	8.75
0	1	0	1	15.0	9.0
0	1	0	0	15.5	9.25
0	0	1	1	16.0	9.5
0	0	1	0	16.5	9.75
0	0	0	1	17.0	10.0
0	0	0	0	17.5	10.25

Logic 0 = Pin 20 potential (remote sense gnd)
Logic 1 = Open circuit (no pull-up resistors)
VID4 may not be changed while the unit is operating.

Ordering Information

PT4475□ = +6.5V to 17.5V

PT Series Suffix (PT1234 x)

Case/Pin Configuration	Order Suffix	Package Code
Vertical	N	(EKD)
Horizontal	A	(EKA)
SMD	C	(EKC)

(Reference the applicable package code drawing for the dimensions and PC board layout)

TYPICAL CHARACTERISTICS

PT4475, V_o = 12.0V (See Note A)

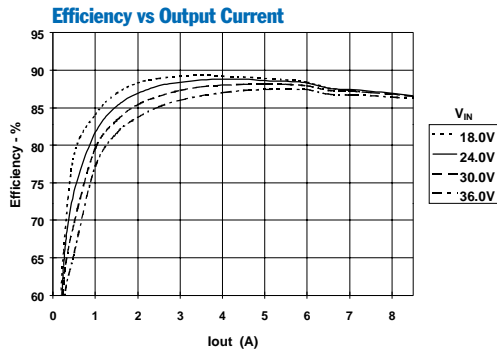

PT4475, V_o = 15.0V (See Note A)

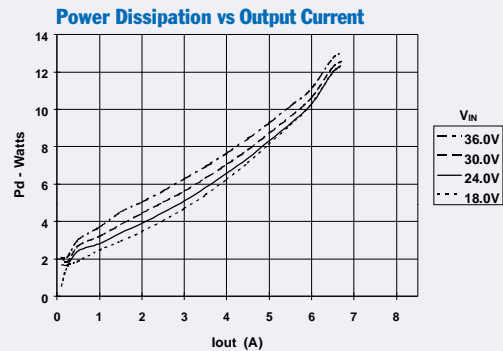
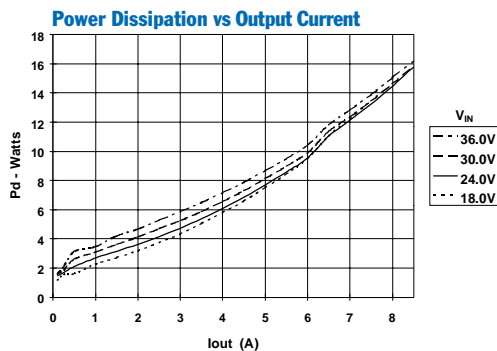
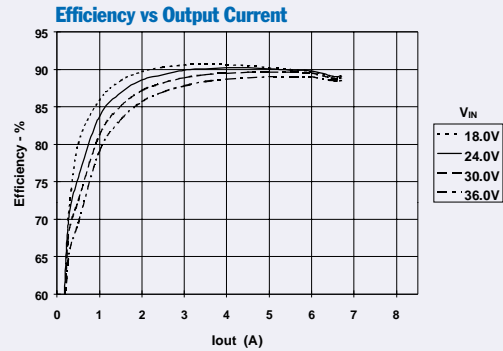

Safe Operating Area, V_o = 12V (See Note B)

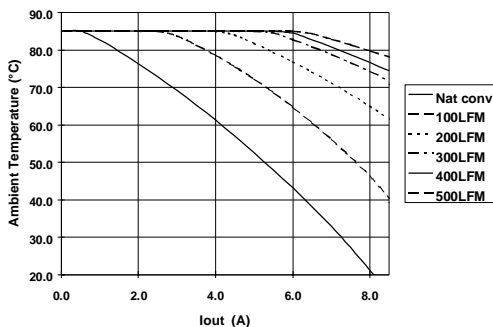

Safe Operating Area, V_o = 15V (See Note B)

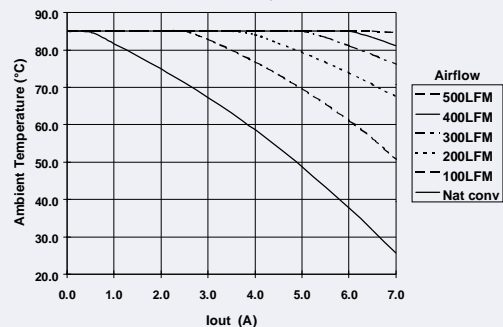

Note A: All data listed in the above graphs has been developed from actual products tested at 25°C. This data is considered typical data for the DC/DC Converter.

Note B: SOA curves represent operating conditions at which the temperature of the metal case is at or below the maximum specified 100°C

PACKAGE INFORMATION AND DIMENSIONS

Vertical Through-Hole Mount (Suffix N)

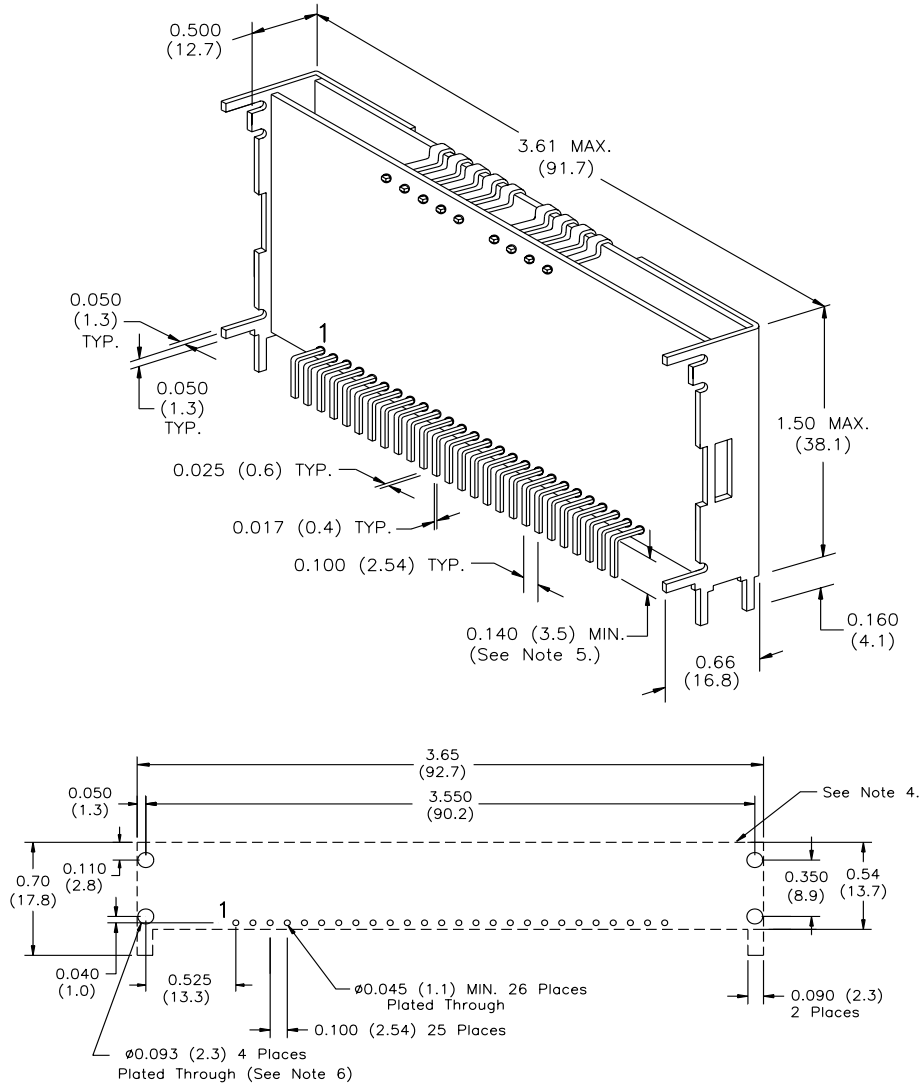

PC Layout

Notes: (Rev. E)

- 1: All dimensions are in inches (mm).
- 2: 2 place decimals are ± 0.030 ($\pm 0.8\text{mm}$).
- 3: 3 place decimals are ± 0.010 ($\pm 0.3\text{mm}$).
- 4: Recommended mechanical keep out area (dotted line).
- 5: Electrical pin length mounted on printed circuit board seating plane to pin end.
- 6: Option (Electrically connect heatsink pins to secondary ground.)

PACKAGE INFORMATION AND DIMENSIONS

Horizontal Through-Hole Mount (Suffix A)

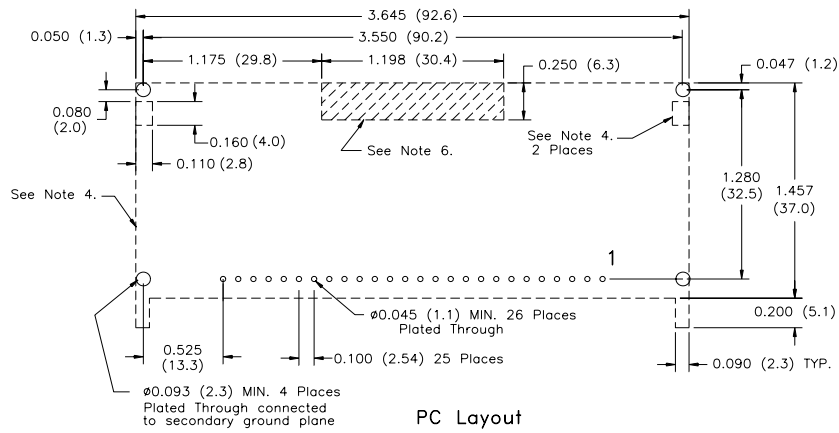
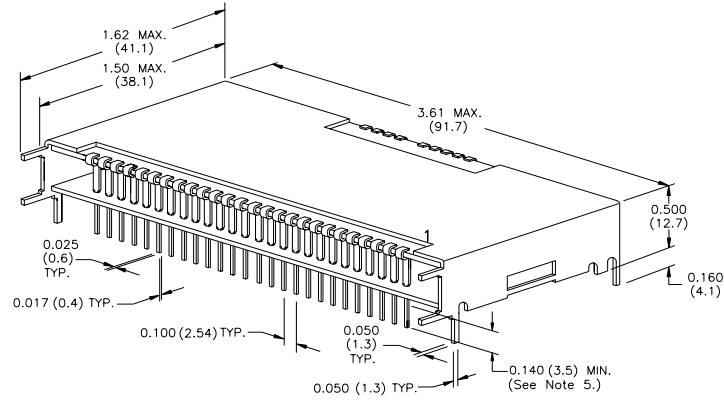

PC Layout

Notes: (Rev. G)

- 1: All dimensions are in inches (mm).
- 2: 2 place decimals are ± 0.030 ($\pm 0.8\text{mm}$).
- 3: 3 place decimals are ± 0.010 ($\pm 0.3\text{mm}$).
- 4: Recommended mechanical keep out area (dotted lines).
- 5: Electrical pin length mounted on printed circuit board seating plane to pin end.
- 6: No copper, power or signal traces in this area.

PACKAGE INFORMATION AND DIMENSIONS

Horizontal Surface Mount (Suffix C)

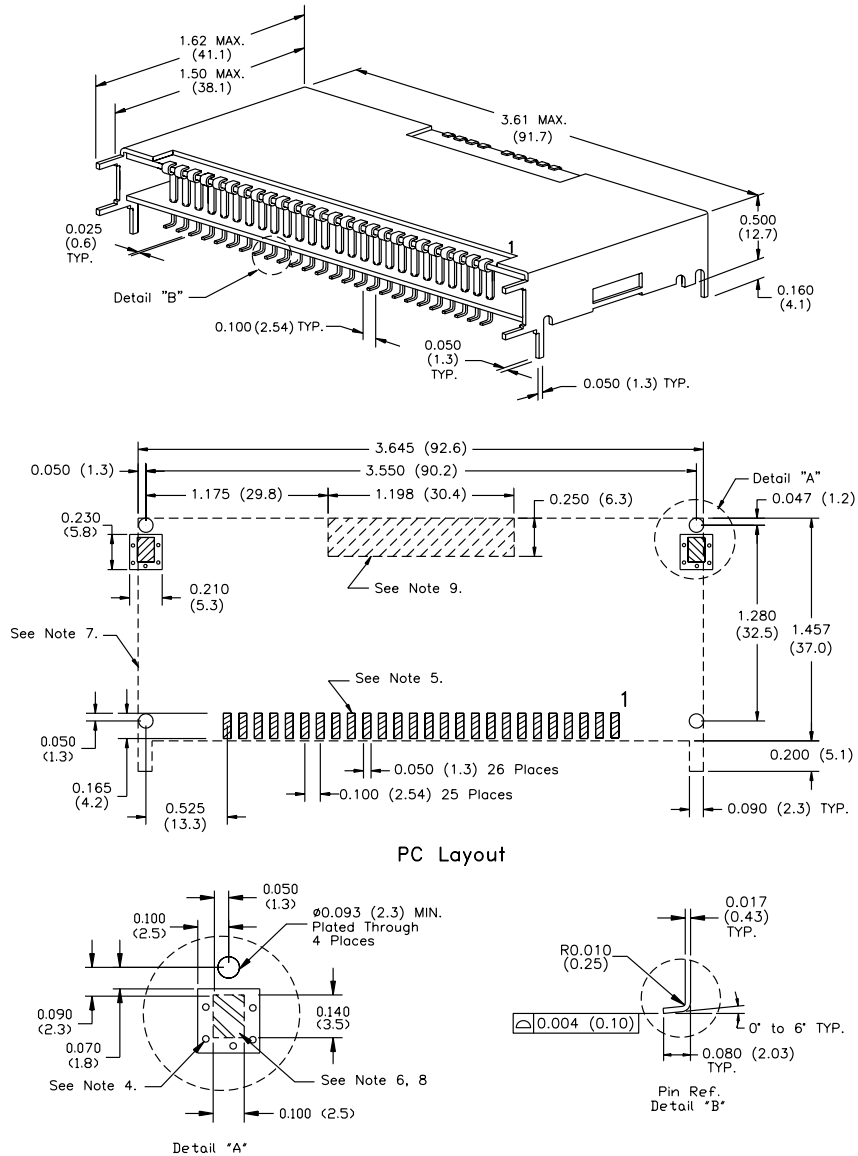

Notes: (Rev. E)

- 1: All dimensions are in inches (mm).
- 2: 2 place decimals are ± 0.030 (± 0.8 mm).
- 3: 3 place decimals are ± 0.010 (± 0.3 mm).
- 4: Vias are recommended to improve copper adhesion.
- 5: Power pin connections should utilize two or more vias per input, ground and output pin.
- 6: Solder mask openings to copper island for solder joints to mechanical pins.
- 7: Recommended mechanical keep out area (dotted lines).
- 8: Electrically connected case to secondary ground plane.
- 9: No copper, power or signal traces in this area.

PACKAGING INFORMATION

Orderable Device	Status ⁽¹⁾	Package Type	Package Drawing	Pins	Package Qty	Eco Plan ⁽²⁾	Lead/ Ball Finish	MSL Peak Temp ⁽³⁾	Samples (Requires Login)
PT4475A	NRND	SIP MODULE	EKA	26	6	TBD	Call TI	Level-1-215C-UNLIM	
PT4475C	OBSOLETE	SIP MODULE	EKC	26		TBD	Call TI	Call TI	

⁽¹⁾ The marketing status values are defined as follows:

ACTIVE: Product device recommended for new designs.

LIFEBUY: TI has announced that the device will be discontinued, and a lifetime-buy period is in effect.

NRND: Not recommended for new designs. Device is in production to support existing customers, but TI does not recommend using this part in a new design.

PREVIEW: Device has been announced but is not in production. Samples may or may not be available.

OBSOLETE: TI has discontinued the production of the device.

⁽²⁾ Eco Plan - The planned eco-friendly classification: Pb-Free (RoHS), Pb-Free (RoHS Exempt), or Green (RoHS & no Sb/Br) - please check <http://www.ti.com/productcontent> for the latest availability information and additional product content details.

TBD: The Pb-Free/Green conversion plan has not been defined.

Pb-Free (RoHS): TI's terms "Lead-Free" or "Pb-Free" mean semiconductor products that are compatible with the current RoHS requirements for all 6 substances, including the requirement that lead not exceed 0.1% by weight in homogeneous materials. Where designed to be soldered at high temperatures, TI Pb-Free products are suitable for use in specified lead-free processes.

Pb-Free (RoHS Exempt): This component has a RoHS exemption for either 1) lead-based flip-chip solder bumps used between the die and package, or 2) lead-based die adhesive used between the die and leadframe. The component is otherwise considered Pb-Free (RoHS compatible) as defined above.

Green (RoHS & no Sb/Br): TI defines "Green" to mean Pb-Free (RoHS compatible), and free of Bromine (Br) and Antimony (Sb) based flame retardants (Br or Sb do not exceed 0.1% by weight in homogeneous material)

⁽³⁾ MSL, Peak Temp. -- The Moisture Sensitivity Level rating according to the JEDEC industry standard classifications, and peak solder temperature.

Important Information and Disclaimer: The information provided on this page represents TI's knowledge and belief as of the date that it is provided. TI bases its knowledge and belief on information provided by third parties, and makes no representation or warranty as to the accuracy of such information. Efforts are underway to better integrate information from third parties. TI has taken and continues to take reasonable steps to provide representative and accurate information but may not have conducted destructive testing or chemical analysis on incoming materials and chemicals. TI and TI suppliers consider certain information to be proprietary, and thus CAS numbers and other limited information may not be available for release.

In no event shall TI's liability arising out of such information exceed the total purchase price of the TI part(s) at issue in this document sold by TI to Customer on an annual basis.

IMPORTANT NOTICE

Texas Instruments Incorporated and its subsidiaries (TI) reserve the right to make corrections, modifications, enhancements, improvements, and other changes to its products and services at any time and to discontinue any product or service without notice. Customers should obtain the latest relevant information before placing orders and should verify that such information is current and complete. All products are sold subject to TI's terms and conditions of sale supplied at the time of order acknowledgment.

TI warrants performance of its hardware products to the specifications applicable at the time of sale in accordance with TI's standard warranty. Testing and other quality control techniques are used to the extent TI deems necessary to support this warranty. Except where mandated by government requirements, testing of all parameters of each product is not necessarily performed.

TI assumes no liability for applications assistance or customer product design. Customers are responsible for their products and applications using TI components. To minimize the risks associated with customer products and applications, customers should provide adequate design and operating safeguards.

TI does not warrant or represent that any license, either express or implied, is granted under any TI patent right, copyright, mask work right, or other TI intellectual property right relating to any combination, machine, or process in which TI products or services are used. Information published by TI regarding third-party products or services does not constitute a license from TI to use such products or services or a warranty or endorsement thereof. Use of such information may require a license from a third party under the patents or other intellectual property of the third party, or a license from TI under the patents or other intellectual property of TI.

Reproduction of TI information in TI data books or data sheets is permissible only if reproduction is without alteration and is accompanied by all associated warranties, conditions, limitations, and notices. Reproduction of this information with alteration is an unfair and deceptive business practice. TI is not responsible or liable for such altered documentation. Information of third parties may be subject to additional restrictions.

Resale of TI products or services with statements different from or beyond the parameters stated by TI for that product or service voids all express and any implied warranties for the associated TI product or service and is an unfair and deceptive business practice. TI is not responsible or liable for any such statements.

TI products are not authorized for use in safety-critical applications (such as life support) where a failure of the TI product would reasonably be expected to cause severe personal injury or death, unless officers of the parties have executed an agreement specifically governing such use. Buyers represent that they have all necessary expertise in the safety and regulatory ramifications of their applications, and acknowledge and agree that they are solely responsible for all legal, regulatory and safety-related requirements concerning their products and any use of TI products in such safety-critical applications, notwithstanding any applications-related information or support that may be provided by TI. Further, Buyers must fully indemnify TI and its representatives against any damages arising out of the use of TI products in such safety-critical applications.

TI products are neither designed nor intended for use in military/aerospace applications or environments unless the TI products are specifically designated by TI as military-grade or "enhanced plastic." Only products designated by TI as military-grade meet military specifications. Buyers acknowledge and agree that any such use of TI products which TI has not designated as military-grade is solely at the Buyer's risk, and that they are solely responsible for compliance with all legal and regulatory requirements in connection with such use.

TI products are neither designed nor intended for use in automotive applications or environments unless the specific TI products are designated by TI as compliant with ISO/TS 16949 requirements. Buyers acknowledge and agree that, if they use any non-designated products in automotive applications, TI will not be responsible for any failure to meet such requirements.

Following are URLs where you can obtain information on other Texas Instruments products and application solutions:

Products

Audio	www.ti.com/audio
Amplifiers	amplifier.ti.com
Data Converters	dataconverter.ti.com
DLP® Products	www.dlp.com
DSP	dsp.ti.com
Clocks and Timers	www.ti.com/clocks
Interface	interface.ti.com
Logic	logic.ti.com
Power Mgmt	power.ti.com
Microcontrollers	microcontroller.ti.com
RFID	www.ti-rfid.com
RF/IF and ZigBee® Solutions	www.ti.com/lprf

Applications

Communications and Telecom	www.ti.com/communications
Computers and Peripherals	www.ti.com/computers
Consumer Electronics	www.ti.com/consumer-apps
Energy and Lighting	www.ti.com/energy
Industrial	www.ti.com/industrial
Medical	www.ti.com/medical
Security	www.ti.com/security
Space, Avionics and Defense	www.ti.com/space-avionics-defense
Transportation and Automotive	www.ti.com/automotive
Video and Imaging	www.ti.com/video
Wireless	www.ti.com/wireless-apps

TI E2E Community Home Page

e2e.ti.com

Mailing Address: Texas Instruments, Post Office Box 655303, Dallas, Texas 75265
Copyright © 2011, Texas Instruments Incorporated