



### Features

- DSL Triple Outputs: +15V, +3.3V, +1.5V (Independantly Regulated)
- Input Voltage Range: 36V to 75V
- 1500VDC Isolation
- On/Off "Standby" Control
- Current Limit
- Short Circuit Protection (All Outputs)
- Fixed Frequency Operation
- Over-Temperature Shutdown
- Under-Voltage Lockout
- Space Saving Package: 1.6 sq. in. PCB Area (suffix N)
- Solderable Copper Case
- Safety Agency Approvals: UL 60950, CSA C22.2 60950, VDE EN60950

### Description

The PT4801 Excalibur™ module is an isolated triple-output DC/DC converter that provides +15V, +3.3V, and +1.5V power supply voltages from a standard (-48V) telecom central office (CO) supply. A typical application is a chip-set for an 8 or 16-channel ADSL/DSL line card, or other mixed signal circuitry. The output voltage combination provides power for a processor core, digital logic, and analog support circuitry. The Vo<sub>2</sub> and Vo<sub>3</sub> outputs are also designed to meet the power-up/down sequencing requirements of popular DSP ICs.

The PT4801 is housed in a space-saving solderable copper case. A heatsink is not required. The vertical configuration occupies only 1.6 in<sup>2</sup> of PCB area.

### Ordering Information

PT4801□ = +15/+3.3/+1.5 Volts

### PT Series Suffix (PT1234 x)

Case/Pin Configuration	Order Suffix	Package Code
Vertical	N	(ENJ)
Horizontal	A	(ENK)
SMD	C	(ENL)

(Reference the applicable package code drawing for the dimensions and PC board layout)

### Pin-Out Information

Pin	Function	Pin	Function
1	Remote (On/Off)	11	COM
2	No Pin	12	Vo <sub>2</sub> Adjust
3	-V <sub>in</sub>	13	No Pin
4	-V <sub>in</sub>	14	Vo <sub>2</sub>
5	N/C	15	Vo <sub>2</sub>
6	+V <sub>in</sub>	16	COM
7	+V <sub>in</sub>	17	COM
8	No Pin	18	Vo <sub>3</sub>
9	No Pin	19	Vo <sub>3</sub> Adjust
10	Vo <sub>1</sub>	20	No Pin

### Typical Application

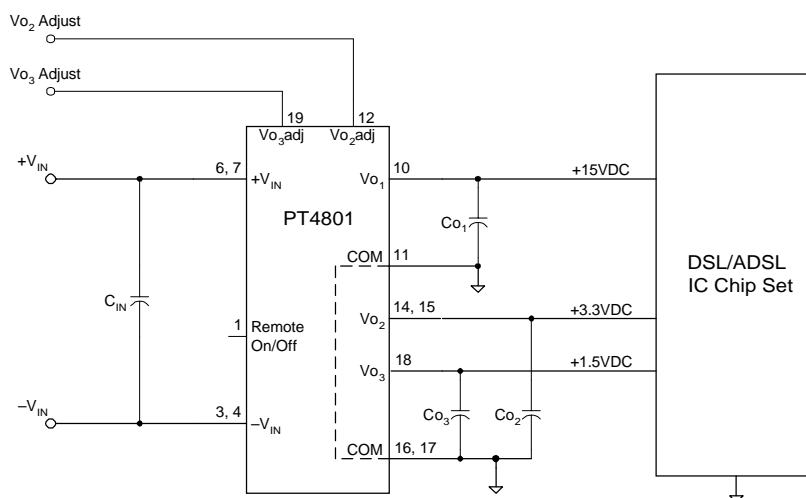

C<sub>in</sub> = Optional 33μF  
Co<sub>1</sub>/Co<sub>2</sub> = Optional 10μF to 330μF per output. (See note 6)

**Electrical Specifications** (Unless otherwise stated,  $T_a = 25^\circ\text{C}$ ,  $V_{in} = 48\text{V}$ ,  $C_{in} = 0\mu\text{F}$ ,  $C_{out} = 0\mu\text{F}$ , and  $I_o = I_{o\text{typ}}$ )

Characteristics	Symbols	Conditions	PT4801 SERIES			Units	
			Min	Typ	Max		
Output Power	$P_o$	Each output:	$V_{o1}$ (15V)	—	15	18.75 (1)	W
			$V_{o2}$ (3.3V)	—	6.6	9.9 (1)	
			$V_{o3}$ (1.5V)	—	2.25	3.0 (1)	
		All three outputs:		—	—	25 (1)	W
Output Current	$I_o$		$V_{o1}$ (15V)	0	1.0	1.25	A
		( $I_{o1} > 0.25\text{A}$ )	$V_{o2}$ (3.3V)	0	2.0	3.0 (2)	A
			$V_{o3}$ (1.5V)	0	1.5	2.0 (2)	A
		( $I_{o1} \leq 0.25\text{A}$ )	$V_{o2}$ (3.3V)	0	—	2.0 (2)	A
			$V_{o3}$ (1.5V)	0	—	1.5 (2)	A
Input Voltage Range	$V_{in}$	Continuous		36	—	75	V
		Surge (1 minute)		—	—	80	V
Set-point Voltage Tolerance	$V_o\text{tol}$		$V_{o1}$	15.0	—	15.75	V
			$V_{o2}$	3.25	3.3	3.35	
			$V_{o3}$	1.45	1.5	1.55	
Temperature Variation	$\text{Reg}_{\text{temp}}$	$-40^\circ \leq T_a \leq +85^\circ\text{C}$ , $I_o = I_{o\text{min}}$		—	$\pm 0.5$	—	% $V_o$
Line Regulation	$\text{Reg}_{\text{line}}$	All outputs, Over $V_{in}$ range, $I_o = I_{o\text{typ}}$		—	0.5	1.0	% $V_o$
Load Regulation	$\text{Reg}_{\text{load}}$	All outputs, $I_o = 10\%$ to $100\%I_{o\text{max}}$		—	0.5	1.0	% $V_o$
Total Output Voltage Variation	$\Delta V_o\text{tot}$	Includes set-point, line load, $-40^\circ\text{C} \leq T_a \leq +85^\circ\text{C}$	$V_{o1}$	15.0	—	15.75	V
			$V_{o2}$	3.2	3.3	3.4	
			$V_{o3}$	1.4	1.5	1.6	
Efficiency	$\eta$	$I_{o1} = 0.5\text{A}$ , $I_{o2} = 1.0\text{A}$ , $I_{o3} = 1.0\text{A}$ $I_{o1} = 1.0\text{A}$ , $I_{o2} = 3.0\text{A}$ , $I_{o3} = 2.0\text{A}$		—	78 81	—	%
$V_o$ Ripple (pk-pk)	$V_r$	20–20Mz bandwidth, $I_o = I_{o\text{typ}}$	$V_{o1}$	—	75	150	mV <sub>pp</sub>
			$V_{o2}$	—	33	50	
			$V_{o3}$	—	30	50	
Transient Response	$t_{tr}$	25% load step from $I_o \geq 0.5I_{o\text{typ}}$		—	300	—	$\mu\text{Sec}$
	$V_{os}$	$V_o$ over/undershoot	$V_{o1}$	—	3	5	% $V_o$
			$V_{o2}$	—	100	150	mV <sub>pp</sub>
			$V_{o3}$	—	100	150	
Output Voltage Adjust	$V_{o\text{adj}}$		$V_{o2}$	3.135	—	3.465	V
			$V_{o3}$	1.425	—	1.5 (4)	
Switching Frequency	$f_s$	Over $V_{in}$ and $I_o$ ranges		550	650	750	kHz
Under-Voltage Lockout	UVLO	$V_{in}$ increasing		—	34	—	V
		$V_{in}$ decreasing		—	33	—	
Remote On/Off (Pin x)		Referenced to $-V_{in}$ (pin 1)					
Input High Voltage	$V_{IH}$			2.5	—	15 (5)	V
Input Low Voltage	$V_{IL}$			–0.2	—	+0.8	
Input Low Current	$I_{IL}$			—	–10	—	$\mu\text{A}$
Standby Input Current	$I_{in\text{ standby}}$	pins 1 & 2 connected		—	8	16	mA
Internal Input Capacitance	$C_{in}$			—	0.76	—	$\mu\text{F}$
External Output Capacitance	$C_{o1}$ , $C_{o2}$ , $C_{o3}$		$V_{o1}$	0	—	330 (6)	$\mu\text{F}$
			$V_{o2}$ & $V_{o3}$ (each)	0	—	330 (6)	
Isolation Voltage		Input–output/input–case		1500	—	—	V
Capacitance		Input to output		—	3000	—	pF
Resistance		Input to output		10	—	—	$\text{M}\Omega$
Operating Temperature Range	$T_a$	Over $V_{in}$ Range		–40	—	+85 (7)	$^\circ\text{C}$
Case Temperature						+100	$^\circ\text{C}$
Over Temperature Protection	OTP			+125			$^\circ\text{C}$
Storage Temperature	$T_s$			–40	—	+125	$^\circ\text{C}$
Mechanical Shock		Method 2002.3		—	500	—	G's
Mil-STD-883D,		1 msec, ½ Sine, mounted					
Mechanical Vibration		Method 2007.2,	Suffixes A, C	—	20 (8)	—	G's
Mil-STD-883D		20–2000 Hz, Soldered					
Weight	—	Vertical/Horizontal		—	50	—	grams
Flammability	—	Meets UL 94V-O					

**Notes:** (1) The sum-total power delivered from all three output,  $V_{o1}$ ,  $V_{o2}$ , and  $V_{o3}$  cannot exceed 25 watts.

(2) When the load current from  $V_{o1}$  is less than 0.25A, the maximum current available from  $V_{o2}$ , and  $V_{o3}$  is reduced to 2A and 1.5A respectively.

(3) The sum-total current from all three outputs  $V_{o1}$ ,  $V_{o2}$ , and  $V_{o3}$  cannot exceed 6Adc.

(4)  $V_{o3}$  cannot be adjusted higher than the nominal output voltage. Consult the applicable application note for information on output voltage adjustment.

(5) The Remote On/Off input has an internal pull-up. If left open circuit the PT4801 will operate when input power is applied. A low-leakage (<100nA) MOSFET is recommended to control this input. The open-circuit voltage is less than 10V. See application notes for interface considerations.

(6) External output capacitance is not required for proper operation. Up to 100 $\mu\text{F}$  of external capacitance may be added to each output to improve the response to load transients. Do not exceed 330 $\mu\text{F}$  at any one output. Allowances must be made for load circuit capacitance and the total external capacitor tolerance. Excessive output capacitance will affect converter start up. Low ESR capacitors, including Os-con® and tantalum types, may be used.

(7) See Safe Operating Area curves, or consult the factory for the appropriate derating.

(8) The case pins on the through-hole package types (suffixes A & N) must be soldered. For more information, see the applicable package outline drawing.

25-W Triple Output Isolated DC/DC Converter for DSL Applications

**PT4801 Characteristic Data** (See Note A)

**Efficiency vs Output Current**

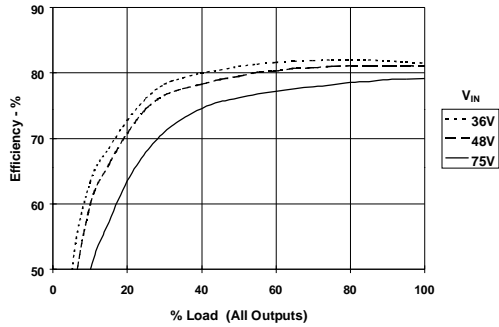

**Load Regulation vs Output Current;  $V_{O1} = +15V$**

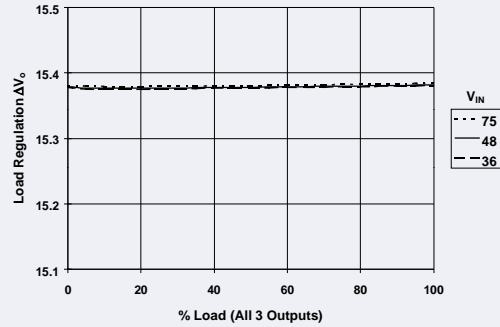

**Ripple vs Output Current; @  $V_{in} = 48V$**

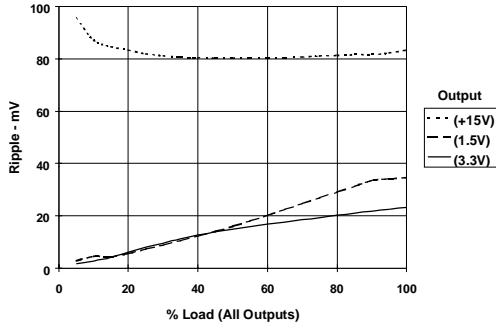

**Load Regulation vs Output Current;  $V_{O2} = +3.3V$**

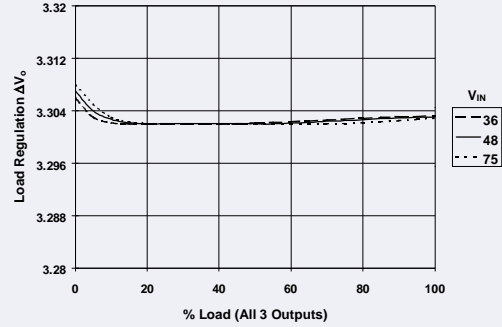

**Power Dissipation vs Output Current**

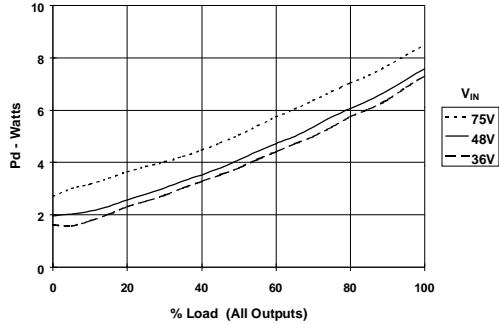

**Load Regulation vs Output Current;  $V_{O3} = +1.5V$**

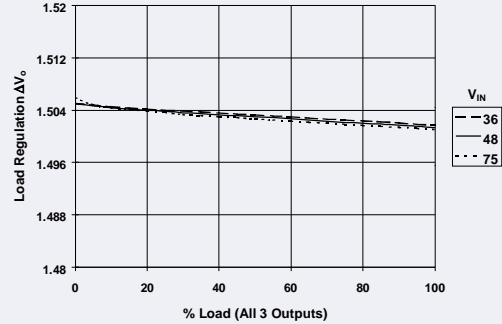

**Safe Operating Area,  $V_{in} = 48V$**  (See Note B)

**PT4801 SOA vs Output Power**

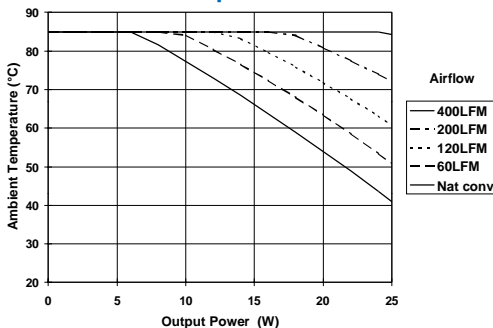

**Note A:** All Characteristic data in the above graphs has been developed from actual products tested at 25°C. This data is considered typical data for the ISR.  
**Note B:** SOA curves represent operating conditions at which internal components are at or below manufacturer's maximum rated operating temperatures.

## Using the Remote On/Off Control on the PT4801 Triple-Output Voltage DC/DC Converter

The three output voltages of the PT4801 triple-output DC/DC converter may be simultaneously disabled using the *Remote On/Off* control. This control is used in applications that require power-up/shutdown sequencing, or wherever there is a requirement to control the on/off status of the module with external circuitry.

On/off control of the PT4801 is provided by pin 1. If pin 1 is left open-circuit the regulator operates normally, and provides a regulated output at all three outputs,  $V_{O1}$  (pin 10),  $V_{O2}$  (pins 14, 15), and  $V_{O3}$  (pin 18), whenever a valid input voltage is applied to  $\pm V_{in}$ . If a low voltage is then applied to pin 1, the module's output will be disabled and the input current it draws will drop to a typical value of 8mA. The *Remote On/Off* input may also be used to hold the module's output in the 'off' state during the period that input power is applied. The input is ideally controlled using an open-collector (or open-drain) discrete transistor (See Figure 1) <sup>3</sup>.

**Table 1 Remote On/Off Control Parameters** <sup>1,2</sup>

Parameter	Min	Typ	Max
Enable ( $V_{IH}$ )	2.5V	—	15V <sup>3</sup>
Disable ( $V_{IL}$ )	-0.1V	—	0.8V

### Notes:

1. The *Remote On/Off* input uses  $-V_{in}$  (pins 3 & 4) as a ground reference, and cannot be directly controlled from circuitry referenced to the isolated output  $\pm V_{o}$ .
2. The internal circuitry comprises of a high impedance ( $3\mu A$  -  $10\mu A$ ) current source. The open-circuit voltage is less than 10V.
3. A low-leakage MOSFET ( $<100nA$ ) is recommended. A pull-up resistor is not required, but may be necessary to ensure that the *Remote On/Off* pin exceeds  $V_{IH}(\min)$  (see Table 1). Do not use a pull-up resistor to the  $+V_{in}$  input, or drive the pin above  $V_{IH}(\max)$ .
4. The PT4801 converter incorporates an "Under Voltage Lockout" (UVLO) function. This function will override the *Remote On/Off* control until the input voltage applied to  $\pm V_{in}$ , is above the UVLO threshold. Consult the data sheet specifications for the on/off input voltage thresholds.
5. Keep the on/off transition to less than 1ms. This prevents erratic operation of the converter, whereby the output voltage may drift un-regulated between 0V and the rated output voltage during power-up.

6. In Figure 1,  $Q_1$  is a low-threshold MOSFET. The components  $R_g$  and  $C_{gs}$  are added to improve noise immunity.

**Figure 1**

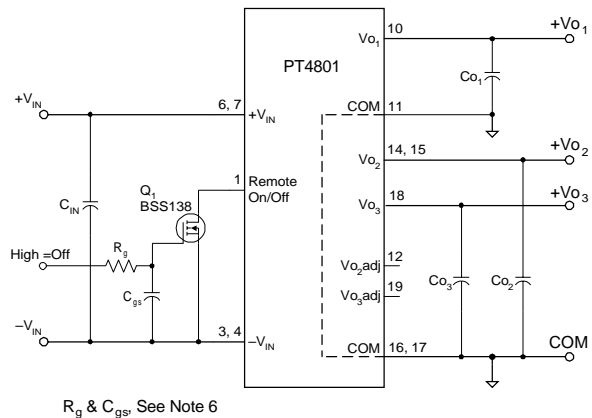

**Power-Up Sequence:** Turning  $Q_1$  in Figure 1 off, removes the low-voltage signal at pin 1 and enables the outputs of the PT4801 converter. After a delay of about 5ms, the  $V_{O1}$  output will begin to rise first. This is closely followed by  $V_{O2}$ , and  $V_{O3}$ , which are internally sequenced to rise in unison. The total power-up time is less than 25ms and is relatively independent of load, and temperature. Figure 2 shows waveforms of all three output voltages,  $V_{O1}$ ,  $V_{O2}$ , and  $V_{O3}$  following  $Q_1$  turning off. The turn off of  $Q_1$  corresponds to the fall in the applied  $V_{gs}$ . The waveforms were measured with a 48V input voltage.

**Figure 2**

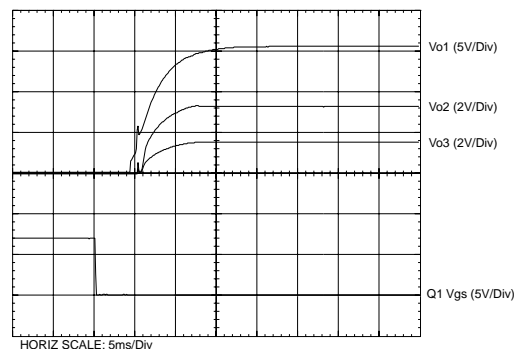

## Adjusting the Output Voltage of the PT4801 Triple-Output DC/DC Converter

The low-voltage outputs from the PT4801 triple-output DC/DC converter,  $V_{O2}$  (3.3V) and  $V_{O3}$  (1.5V), can be independently adjusted from the factory trimmed preset value. Note that the primary use of this feature is for margin testing of the on-board supply voltages. A permanent increase in output voltage is not advised <sup>1</sup>. Also, due to design limitations,  $V_{O3}$  cannot be adjusted higher than its nominal value.

To adjust each output, a single external resistor is added to the circuit in either the “Adjust Up” or “Adjust Down” position (See Figure 1) <sup>2</sup>. Table 1 gives the allowable adjustment range for each output as  $V_a$  (min) and  $V_a$  (max).

**$V_{O2}$  Adjust Up:** Add a resistor  $R_2$  between pin 12 ( $V_{O2}$  Adj), and pin 11 (COM) <sup>1</sup>.

**$V_{O2}$  Adjust Down:** Add a resistor ( $R_1$ ) between pin 12 ( $V_{O2}$  Adj), and pin 14 ( $V_{O2}$ ).

**$V_{O3}$  Adjust Up:**  $V_{O3}$  cannot be adjusted higher.

**$V_{O3}$  Adjust Down:** Add a resistor ( $R_3$ ) between pin 19 ( $V_{O3}$  Adj), and pin 18 ( $V_{O3}$ ).

Refer to Figure 1 and Table 2 for both the placement and value of the adjust resistor.

### Notes:

1. The high-side adjust range of the  $V_{O2}$  output may be limited by the input voltage and/or the load current status of all three outputs. This situation would most likely be encountered when  $V_{O1}$  is lightly loaded and either  $V_{O2}$  or  $V_{O3}$  is operating close to full load.
2. Use only a single 1% resistor in either the ( $R_1$ ) or  $R_2$  location to adjust  $V_{O2}$ , and in the ( $R_3$ ) location to adjust  $V_{O3}$ . Place the resistor as close to the ISR as possible.
3. Never connect capacitors to either of the output adjust control pins. Any capacitance added to these control pins will affect the stability of the respective regulated output.

The adjust up and adjust down resistor values can be calculated using the following formulas. Be sure to select the correct formula parameter from Table 1 for the output being adjusted.

$$(R_1) \text{ or } (R_3) = \frac{R_o (V_a - V_r)}{(V_o - V_a)} - R_s \text{ k}\Omega$$

$$R_2 = \frac{R_o \cdot V_r}{(V_a - V_o)} - R_s \text{ k}\Omega$$

Where  $V_o$  = Original output voltage  
 $V_a$  = Adjusted output voltage  
 $V_r$  = Reference voltage (Table 1)  
 $R_o$  = Multiplier resistor (Table 1)  
 $R_s$  = Series resistance (Table 1)

Figure 1

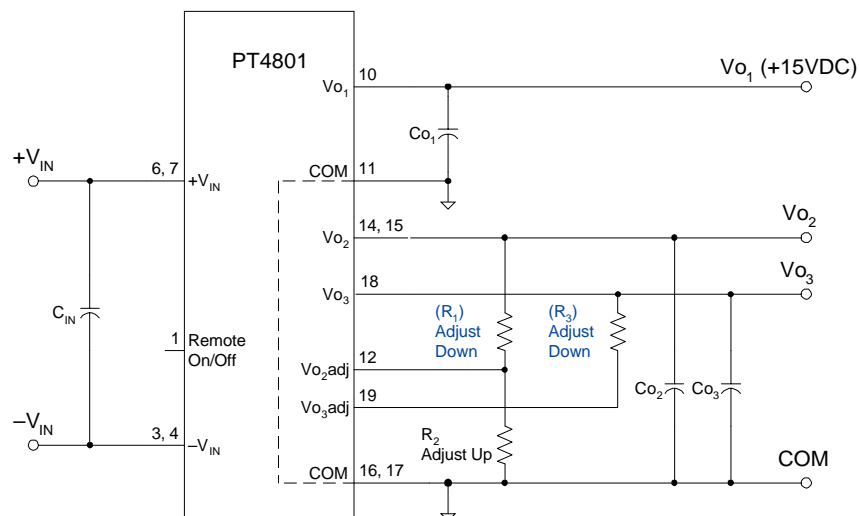

PT4801

**Table 1**

ADJUSTMENT RANGE AND FORMULA PARAMETERS		
Vo <sub>2</sub> Bus		Vo <sub>3</sub> Bus
Adj. Resistor	(R1)/R2	(R3)
V <sub>o</sub> (nom)	3.3V	1.5V
V <sub>a</sub> (min)	3.135V	1.425V
V <sub>a</sub> (max)	3.465V *	—
V <sub>r</sub>	1.225V	1.225V
R <sub>o</sub> (V-kΩ)	11.0	7.5
R <sub>s</sub> (kΩ)	40.2	5.36

\* See Note 1

**Table 2**

ADJUSTMENT RESISTOR VALUES		
Vo <sub>1</sub> Bus		Vo <sub>2</sub> Bus
Adj. Resistor	(R1)/R2	Adj. Resistor (R3)
V <sub>o</sub> (nom)	3.3V	V <sub>o</sub> (nom) 1.5V
V <sub>a</sub> (req'd)		V <sub>a</sub> (req'd)
3.135	(87.1)kΩ	1.425 (14.6)kΩ
3.15	(101.0)kΩ	1.44 (21.5)kΩ
3.165	(118.0)kΩ	1.455 (33.0)kΩ
3.18	(139.0)kΩ	1.47 (55.9)kΩ
3.195	(166.0)kΩ	1.485 (125.0)kΩ
3.21	(202.0)kΩ	1.5
3.225	(253.0)kΩ	
3.24	(329.0)kΩ	
3.255	(456.0)kΩ	
3.27	(710.0)kΩ	
3.285		
3.3		
3.315		
3.33	409.0kΩ	
3.345	259.0kΩ	
3.36	184.0kΩ	
3.375	139.0kΩ	
3.39	110.0kΩ	
3.405	88.1kΩ	
3.42	72.1kΩ	
3.435	59.6kΩ	
3.45	49.6kΩ	
3.465	41.5kΩ	

R<sub>1</sub>/R<sub>3</sub> = (Blue), R<sub>2</sub>/R<sub>4</sub> = Black

## **VDE Approved Installation Instructions (Installationsanleitung)**

Nennspannung (Rated Voltage): PT4801 36 to 72 Vdc, Transient to 80Vdc  
Nennaufnahme (Rated Input): PT4801 1.5 Adc  
Nennleistung (Rated Power): 25 Watts Maximum  
Ausgangsspannung (Sec. Voltage): PT4801 Series  
PT4801, +15/ +3.3/ +1.5 Vdc, 1.25 Adc/ 3.0 Adc/ 2.0 Adc  
Ausgangsstrom (Sec. Current): Maximum total current is 6.0 Adc or 25 Watts  
oder (or)  
Ausgangsleistung (Sec. Power):

Angabe der Umgebungstemperatur

(Information on ambient temperature): +85 °C maximum

Besondere Hinweise (Special Instructions):

Es ist vorzusehen, daß die Spannungsversorgung in einer Endanwendung über eine isolierte Sekundärschaltung bereit gestellt wird. Die Eingangsspannung der Spannungsversorgungsmodule muss eine verstärkte Isolierung von der Wechselstromquelle aufweisen.

Die Spannungsversorgung muss gemäss den Gehäuse-, Montage-, Kriech- und Luftstrecken-, Markierungs- und Trennanforderungen der Endanwendung installiert werden. Bei Einsatz eines TNV-3-Einganges muss die SELV-Schaltung ordnungsgemäss geerdet werden.

(The power supply is intended to be supplied by isolated secondary circuitry in an end use application. The input power to these power supplies shall have reinforced insulation from the AC mains.)

The power supply shall be installed in compliance with the enclosure, mounting, creepage, clearance, casualty, markings, and segregation requirements of the end-use application. When the input is TNV-3, the SELV circuitry must be reliably grounded.)

Offenbach,

**VDE Prüf- und Zertifizierungsinstitut**  
Abteilung / Department TD

(Jürgen Bärwinkel)

Ort / Place:

Datum / Date:

*K. Yena* 12/12/01

(Stempel und Unterschrift des Herstellers / Stamp and signature of the manufacturer)

**PACKAGING INFORMATION**

Orderable Device	Status <sup>(1)</sup>	Package Type	Package Drawing	Pins	Package Qty	Eco Plan <sup>(2)</sup>	Lead/ Ball Finish	MSL Peak Temp <sup>(3)</sup>	Samples (Requires Login)
PT4801C	OBSOLETE	SIP MODULE	ENL	20		TBD	Call TI	Call TI	

<sup>(1)</sup> The marketing status values are defined as follows:

**ACTIVE:** Product device recommended for new designs.

**LIFEBUY:** TI has announced that the device will be discontinued, and a lifetime-buy period is in effect.

**NRND:** Not recommended for new designs. Device is in production to support existing customers, but TI does not recommend using this part in a new design.

**PREVIEW:** Device has been announced but is not in production. Samples may or may not be available.

**OBSOLETE:** TI has discontinued the production of the device.

<sup>(2)</sup> Eco Plan - The planned eco-friendly classification: Pb-Free (RoHS), Pb-Free (RoHS Exempt), or Green (RoHS & no Sb/Br) - please check <http://www.ti.com/productcontent> for the latest availability information and additional product content details.

**TBD:** The Pb-Free/Green conversion plan has not been defined.

**Pb-Free (RoHS):** TI's terms "Lead-Free" or "Pb-Free" mean semiconductor products that are compatible with the current RoHS requirements for all 6 substances, including the requirement that lead not exceed 0.1% by weight in homogeneous materials. Where designed to be soldered at high temperatures, TI Pb-Free products are suitable for use in specified lead-free processes.

**Pb-Free (RoHS Exempt):** This component has a RoHS exemption for either 1) lead-based flip-chip solder bumps used between the die and package, or 2) lead-based die adhesive used between the die and leadframe. The component is otherwise considered Pb-Free (RoHS compatible) as defined above.

**Green (RoHS & no Sb/Br):** TI defines "Green" to mean Pb-Free (RoHS compatible), and free of Bromine (Br) and Antimony (Sb) based flame retardants (Br or Sb do not exceed 0.1% by weight in homogeneous material)

<sup>(3)</sup> MSL, Peak Temp. -- The Moisture Sensitivity Level rating according to the JEDEC industry standard classifications, and peak solder temperature.

**Important Information and Disclaimer:** The information provided on this page represents TI's knowledge and belief as of the date that it is provided. TI bases its knowledge and belief on information provided by third parties, and makes no representation or warranty as to the accuracy of such information. Efforts are underway to better integrate information from third parties. TI has taken and continues to take reasonable steps to provide representative and accurate information but may not have conducted destructive testing or chemical analysis on incoming materials and chemicals. TI and TI suppliers consider certain information to be proprietary, and thus CAS numbers and other limited information may not be available for release.

In no event shall TI's liability arising out of such information exceed the total purchase price of the TI part(s) at issue in this document sold by TI to Customer on an annual basis.

## IMPORTANT NOTICE

Texas Instruments Incorporated and its subsidiaries (TI) reserve the right to make corrections, modifications, enhancements, improvements, and other changes to its products and services at any time and to discontinue any product or service without notice. Customers should obtain the latest relevant information before placing orders and should verify that such information is current and complete. All products are sold subject to TI's terms and conditions of sale supplied at the time of order acknowledgment.

TI warrants performance of its hardware products to the specifications applicable at the time of sale in accordance with TI's standard warranty. Testing and other quality control techniques are used to the extent TI deems necessary to support this warranty. Except where mandated by government requirements, testing of all parameters of each product is not necessarily performed.

TI assumes no liability for applications assistance or customer product design. Customers are responsible for their products and applications using TI components. To minimize the risks associated with customer products and applications, customers should provide adequate design and operating safeguards.

TI does not warrant or represent that any license, either express or implied, is granted under any TI patent right, copyright, mask work right, or other TI intellectual property right relating to any combination, machine, or process in which TI products or services are used. Information published by TI regarding third-party products or services does not constitute a license from TI to use such products or services or a warranty or endorsement thereof. Use of such information may require a license from a third party under the patents or other intellectual property of the third party, or a license from TI under the patents or other intellectual property of TI.

Reproduction of TI information in TI data books or data sheets is permissible only if reproduction is without alteration and is accompanied by all associated warranties, conditions, limitations, and notices. Reproduction of this information with alteration is an unfair and deceptive business practice. TI is not responsible or liable for such altered documentation. Information of third parties may be subject to additional restrictions.

Resale of TI products or services with statements different from or beyond the parameters stated by TI for that product or service voids all express and any implied warranties for the associated TI product or service and is an unfair and deceptive business practice. TI is not responsible or liable for any such statements.

TI products are not authorized for use in safety-critical applications (such as life support) where a failure of the TI product would reasonably be expected to cause severe personal injury or death, unless officers of the parties have executed an agreement specifically governing such use. Buyers represent that they have all necessary expertise in the safety and regulatory ramifications of their applications, and acknowledge and agree that they are solely responsible for all legal, regulatory and safety-related requirements concerning their products and any use of TI products in such safety-critical applications, notwithstanding any applications-related information or support that may be provided by TI. Further, Buyers must fully indemnify TI and its representatives against any damages arising out of the use of TI products in such safety-critical applications.

TI products are neither designed nor intended for use in military/aerospace applications or environments unless the TI products are specifically designated by TI as military-grade or "enhanced plastic." Only products designated by TI as military-grade meet military specifications. Buyers acknowledge and agree that any such use of TI products which TI has not designated as military-grade is solely at the Buyer's risk, and that they are solely responsible for compliance with all legal and regulatory requirements in connection with such use.

TI products are neither designed nor intended for use in automotive applications or environments unless the specific TI products are designated by TI as compliant with ISO/TS 16949 requirements. Buyers acknowledge and agree that, if they use any non-designated products in automotive applications, TI will not be responsible for any failure to meet such requirements.

Following are URLs where you can obtain information on other Texas Instruments products and application solutions:

### Products

Audio	<a href="http://www.ti.com/audio">www.ti.com/audio</a>
Amplifiers	<a href="http://amplifier.ti.com">amplifier.ti.com</a>
Data Converters	<a href="http://dataconverter.ti.com">dataconverter.ti.com</a>
DLP® Products	<a href="http://www.dlp.com">www.dlp.com</a>
DSP	<a href="http://dsp.ti.com">dsp.ti.com</a>
Clocks and Timers	<a href="http://www.ti.com/clocks">www.ti.com/clocks</a>
Interface	<a href="http://interface.ti.com">interface.ti.com</a>
Logic	<a href="http://logic.ti.com">logic.ti.com</a>
Power Mgmt	<a href="http://power.ti.com">power.ti.com</a>
Microcontrollers	<a href="http://microcontroller.ti.com">microcontroller.ti.com</a>
RFID	<a href="http://www.ti-rfid.com">www.ti-rfid.com</a>
RF/IF and ZigBee® Solutions	<a href="http://www.ti.com/lprf">www.ti.com/lprf</a>

### Applications

Communications and Telecom	<a href="http://www.ti.com/communications">www.ti.com/communications</a>
Computers and Peripherals	<a href="http://www.ti.com/computers">www.ti.com/computers</a>
Consumer Electronics	<a href="http://www.ti.com/consumer-apps">www.ti.com/consumer-apps</a>
Energy and Lighting	<a href="http://www.ti.com/energy">www.ti.com/energy</a>
Industrial	<a href="http://www.ti.com/industrial">www.ti.com/industrial</a>
Medical	<a href="http://www.ti.com/medical">www.ti.com/medical</a>
Security	<a href="http://www.ti.com/security">www.ti.com/security</a>
Space, Avionics and Defense	<a href="http://www.ti.com/space-avionics-defense">www.ti.com/space-avionics-defense</a>
Transportation and Automotive	<a href="http://www.ti.com/automotive">www.ti.com/automotive</a>
Video and Imaging	<a href="http://www.ti.com/video">www.ti.com/video</a>
Wireless	<a href="http://www.ti.com/wireless-apps">www.ti.com/wireless-apps</a>

TI E2E Community Home Page

[e2e.ti.com](http://e2e.ti.com)

Mailing Address: Texas Instruments, Post Office Box 655303, Dallas, Texas 75265  
Copyright © 2011, Texas Instruments Incorporated