



### Features

- 12 V Input
- 11 A Output Current
- DSP Compatible
- >90 % Efficiency
- Adjustable Output Voltage
- On/Off Inhibit Function
- Over-Current Protection
- Output Remote Sense
- Low-Profile (8 mm)
- Small Footprint (0.64 in<sup>2</sup>, Suffix 'N')
- Surface Mountable
- IPC Lead Free 2

### Description

The PT6360 Excalibur™ series of integrated switching regulators (ISRs) combines outstanding power density with a comprehensive list of features. They are an ideal choice for applications where board space is a premium and performance cannot be compromised. These modules provide up to 11 A of output current, yet are housed in a low-profile, 12-pin, package that is almost half the size of the previous product generation. The integral copper case construction requires no heatsink, and offers the advantages of solderability and a small footprint (0.64 in<sup>2</sup> for suffix 'N'). Both through-hole and surface mount pin configurations are available.

The PT6360 series operates from a 12-V input bus and provides a convenient point-of-load power source for the industry's latest high-performance DSPs and microprocessors. The series includes output voltage options as low as 1.0 VDC.

Other features include external output voltage adjustment, on/off inhibit, short circuit protection, and an output remote sense.

### Ordering Information

PT6361□	= 5.0 Volts
PT6362□	= 3.3 Volts
PT6363□	= 2.5 Volts
PT6364□	= 1.8 Volts
PT6365□	= 1.5 Volts
PT6366□	= 1.2 Volts
PT6367□	= 1.0 Volts

### PT Series Suffix (PT1234 x)

Case/Pin Configuration	Order Suffix	Package Code
Vertical	<b>N</b>	(EPH)
Horizontal	<b>A</b>	(EPJ)
SMD	<b>C</b>	(EPK)

(Reference the applicable package code drawing for the dimensions and PC board layout)

### Pin-Out Information

Pin	Function
1	Inhibit*
2	V <sub>in</sub>
3	V <sub>in</sub>
4	V <sub>in</sub>
5	GND
6	GND
7	GND
8	GND
9	V <sub>out</sub>
10	V <sub>out</sub>
11	(+)Sense
12	V <sub>o</sub> Adjust

\* Denotes negative logic:  
Open = Output enabled  
Ground = Output disabled

### Standard Application

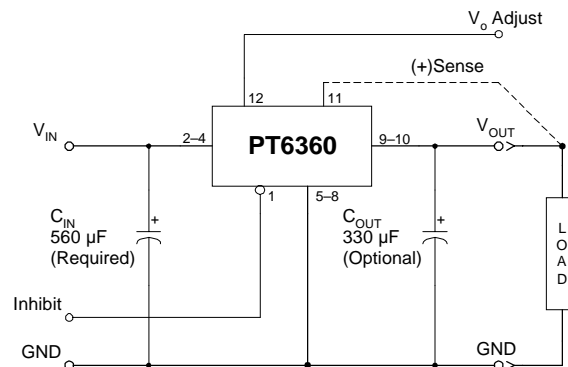

C<sub>in</sub> = Required 560 µF  
C<sub>out</sub> = Optional 330 µF

**Performance Specifications** (Unless otherwise stated,  $T_a = 25^\circ\text{C}$ ,  $V_{in} = 12\text{ V}$ ,  $C_{in} = 560\ \mu\text{F}$ ,  $C_{out} = 0\ \mu\text{F}$ , and  $I_o = I_{o,max}$ )

Characteristics	Symbols	Conditions	PT6360 SERIES			Units
			Min	Typ	Max	
Output Current	$I_o$	$V_{in} = 12\text{ V}$ $V_o < 3.3\text{ V}$ $V_o \geq 3.3\text{ V}$	0 0	— —	11 10	A
Input Voltage Range	$V_{in}$	Over $I_o$ range	10.8	—	13.2	V
Set-Point Voltage Tolerance	$V_o\text{ tol}$		—	—	$\pm 2$	$\%V_o$
Temperature Variation	$\Delta\text{Reg}_{temp}$	$-40^\circ\text{C} < T_a < +85^\circ\text{C}$	—	$\pm 0.5$	—	$\%V_o$
Line Regulation	$\Delta\text{Reg}_{line}$	Over $V_{in}$ range	—	$\pm 3$	—	mV
Load Regulation	$\Delta\text{Reg}_{load}$	Over $I_o$ range	—	$\pm 5$	—	mV
Total Output Variation	$\Delta\text{Reg}_{tot}$	Includes set-point, line, load, $-40^\circ\text{C} \leq T_a \leq +85^\circ\text{C}$	—	—	$\pm 3$	$\%V_o$
Efficiency	$\eta$	$I_o = 8\text{ A}$ PT6361 (5 V) PT6362 (3.3 V) PT6363 (2.5 V) PT6364 (1.8 V) PT6365 (1.5 V) PT6366 (1.2 V) PT6367 (1.0 V)	— — — — — — —	93 91 90 87 85 82 80	— — — — — — —	%
$V_o$ Ripple (pk-pk)	$V_r$	20 MHz bandwidth $V_o = 5.0\text{ V}$ $V_o = 3.3\text{ V}$ $V_o \leq 2.5\text{ V}$	— — —	50 25 15	— — —	mV <sub>pp</sub>
Transient Response		1 A/ $\mu\text{s}$ load step, 50 to 100 % $I_{o,max}$ , $C_{out} = 330\ \mu\text{F}$				
	$t_{tr}$	Recovery Time	—	50	—	$\mu\text{Sec}$
	$\Delta V_{tr}$	$V_o$ over/undershoot	—	70	—	mV
Over-Current Threshold	$I_{TRIP}$	Reset, followed by auto-recovery	—	16	—	A
Output Voltage Adjust	$V_o\text{ adj}$	With $V_o$ Adjust	—	$\pm 15$ (1)	—	%
Switching Frequency	$f_s$	Over $V_{in}$ and $I_o$ ranges	300	350	400	kHz
Inhibit Control (pin1)		Referenced to GND (pins 5–8)				
Input High Voltage	$V_{IH}$		2	—	Open (2)	V
Input Low Voltage	$V_{IL}$		–0.2	—	0.3	
Input Low Current	$I_{IL}$	Pin 1 to GND	—	–10	—	$\mu\text{A}$
Standby Input Current	$I_{in\ standby}$	Pin 1 to GND	—	5	—	mA
External Input Capacitance	$C_{in}$		560 (3)	—	—	$\mu\text{F}$
External Output Capacitance	$C_{out}$		0	330 (4)	5,000	$\mu\text{F}$
Operating Temperature Range	$T_a$	Over $V_{in}$ range	–40	—	85 (5)	$^\circ\text{C}$
Solder Reflow Temperature	$T_{reflow}$	Surface temperature of pins or case	—	—	215 (6)	$^\circ\text{C}$
Storage Temperature	$T_s$	—	–40	—	125	$^\circ\text{C}$
Reliability	MTBF	Per Bellcore TR-332 50% stress, $T_a = 40^\circ\text{C}$ , ground benign	8.0	—	—	$10^6\text{ Hrs}$
Mechanical Shock		Mil-STD-883D, Method 2002.3 Half Sine, mounted to a fixture	—	500	—	G's
Mechanical Vibration		Mil-STD-883D, Method 2007.2, 20–2000 Hz, PCB mounted	—	20 (7)	—	G's
Weight	—	—	—	10	—	grams
Flammability	—	Materials meet UL 94V-0	—	—	—	—

**Notes:** (1) This is a typical value. For the adjustment limits of a specific model consult the related application note on output voltage adjustment.

(2) The Inhibit control (pin 1) has an internal pull-up to  $V_{in}$ , and if left open-circuit the module will operate when input power is applied. A small low-leakage (<100 nA) MOSFET is recommended to control this input. See application notes for more information.

(3) A 560  $\mu\text{F}$  electrolytic input capacitor is required for proper operation. The capacitor must be rated for a minimum of 1.3 Arms of ripple current.

(4) An external output capacitor is not required for basic operation. Adding 330 $\mu\text{F}$  of distributed capacitance at the load will improve the transient response, and reduce output ripple voltage.

(5) See SOA curves or consult factory for the appropriate derating.

(6) During solder reflow of SMD package version do not elevate the module case, pins, or internal component temperatures above a peak of 215  $^\circ\text{C}$ . For further guidance refer to the application note, "Reflow Soldering Requirements for Plug-in Power Surface Mount Products," (SLTA051).

(7) The case pins on the through-hole package types (suffixes N & A) must be soldered. For more information see the applicable package outline drawing.

### Pin Descriptions

**V<sub>in</sub>:** The positive supply voltage input for the module with respect to the common *GND*.

**V<sub>out</sub>:** This is the regulated output voltage from the module with respect to the common *GND*.

**GND:** The common node to which the input, output, and external control signals are referenced.

**Inhibit\*:** This is an open-collector (open-drain) negative logic input, that is referenced to *GND*. Driving this pin to *GND* disables the module's output voltage. If *Inhibit\** is left open-circuit, the output will be active whenever a valid input source is applied.

**V<sub>o</sub> Adjust:** This pin is used to trim the output voltage to a value within the range of approximately  $\pm 15\%$  of nominal. The adjustment method uses an external resistor. The resistor is connected from *V<sub>o</sub> Adjust* to either the *GND* or *(+)Sense*, in order to adjust the output either up or down, respectively.

**(+)Sense:** An external remote sense input is provided to allow the regulation circuit to compensate for voltage drop between the module and the load. For optimal voltage accuracy *(+)Sense* should be connected to *V<sub>out</sub>*. If desired, *(+)Sense* may also be left open circuit.

### Typical Characteristics

Performance Data; V<sub>in</sub> = 12 V (See Note A)

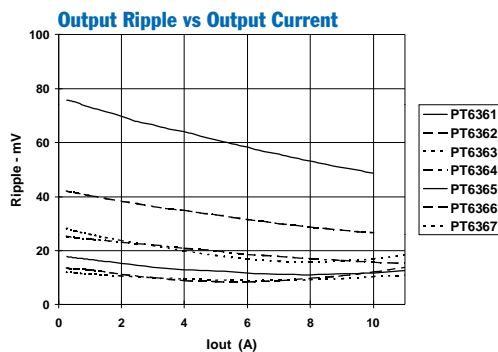
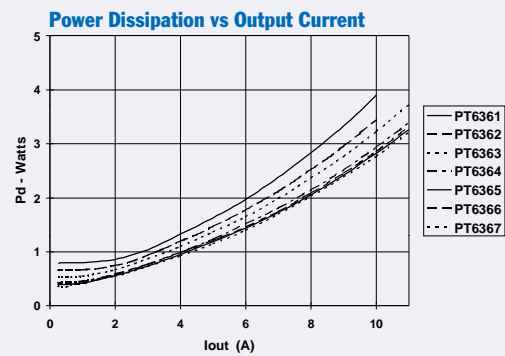
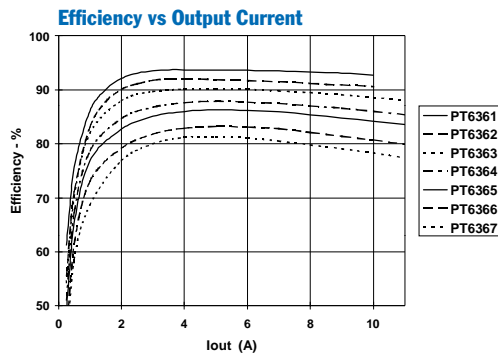

**Note A:** Characteristic data has been developed from actual products tested at 25°C. This data is considered typical data for the ISR.

### Safe Operating Curves, $V_{in} = 12\text{ V}$ (See Note B)

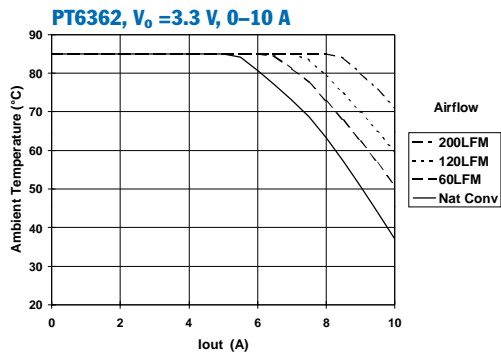
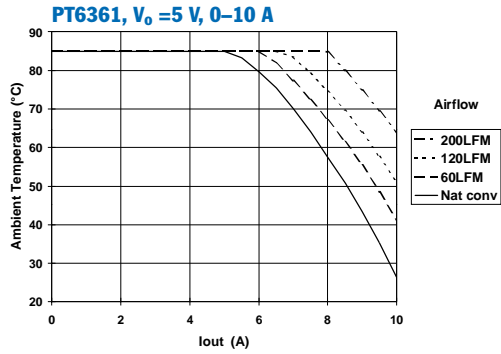

### Safe Operating Curves, $V_{in} = 12\text{ V}$ (See Note B)

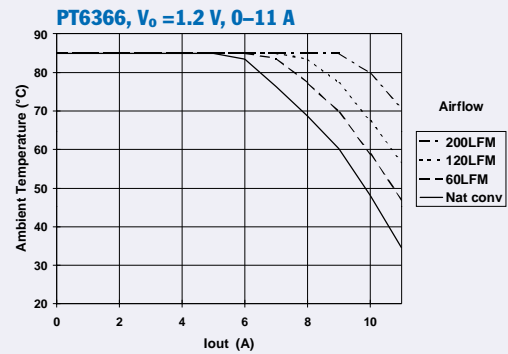
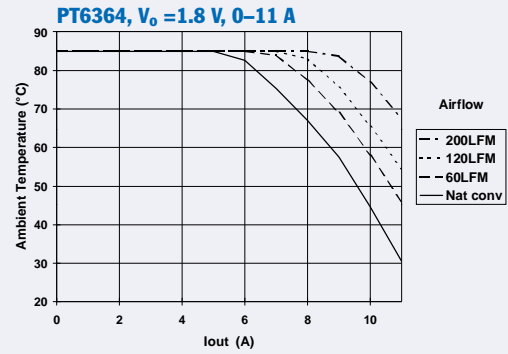
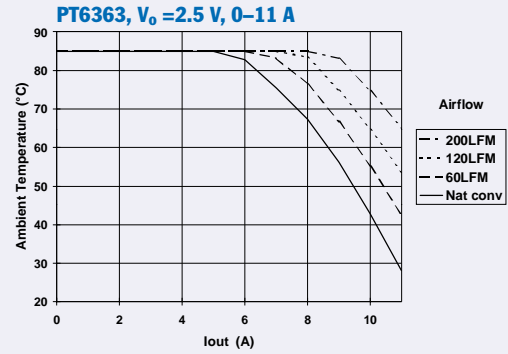

**Note B:** SOA curves represent operating conditions at which internal components are at or below manufacturer's maximum rated operating temperatures.

## Operating Features and System Considerations for the PT6360 Regulator Series

The PT6360 is a series of integrated switching regulators (ISRs) that operate off a 12-V input to provide step-down voltage conversion for output loads of up to 11 A.

### Power up & Soft-Start Timing

Following either the application of a valid input source voltage, or the removal of a ground signal to the *Inhibit* control pin (with input power applied), the regulator will initiate a soft-start power up. A soft start slows the rate at which the output voltage rises and introduces a short time delay,  $t_d$  (approx. 10 ms), into the power-up sequence. Figure 1-1 shows the power-up characteristic of a PT6363 (2.5-V output) with an 8.3-A load. Note that the initial step of input current when the input voltage begins to rise is the input capacitor(s) charging.

Figure 1-1

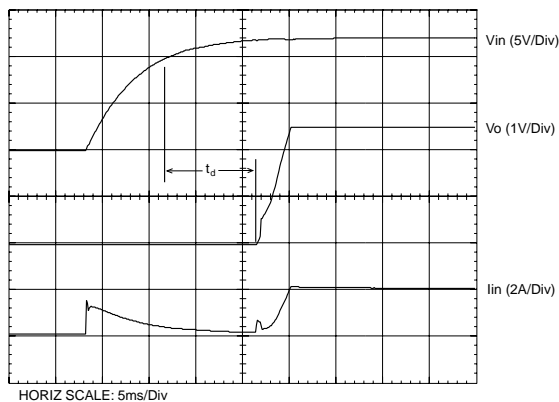

### Over-Current Protection

To protect against load faults, these ISRs incorporate output over-current protection. Applying a load that exceeds the over-current threshold (see data sheet specifications) will cause the regulated output to shut down. Following shutdown the ISR will periodically attempt to recover by initiating a soft-start power-up. This is often described as a “hiccup” mode of operation, whereby the module continues in a cycle of successive shutdown and power up until the load fault is removed. During this period, the average current flowing into the fault is significantly reduced. Once the fault is removed, the converter automatically recovers and returns to normal operation.

### Output Remote Sense

The (+)Sense pin allows the regulator to compensate for limited amounts of ‘IR’ voltage drop in the positive output connection resistance. This is the voltage drop incurred in the PCB trace between  $V_{out}$  (pins 9 & 10) of the regulator and the load some distance away. Connecting (+)Sense to the positive load terminal improves the voltage regulation at the load, particularly when the load current fluctuates. Although not recommended, leaving (+)Sense disconnected will not damage the regulator or the load circuitry. An internal 10  $\Omega$  resistor, connected between the sense pin and the output, keeps the output voltage in regulation.

With the sense pin connected, the difference between the voltage measured between  $V_{out}$  and GND at the regulator, and that measured from (+)Sense to GND, is the amount of IR drop being compensated by the regulator. This should be limited to 0.3 V maximum.

*Note: The remote sense feature is not designed to compensate for the forward drop of non-linear or frequency dependent components that may be placed in series with the converter output. Examples include OR-ing diodes, filter inductors, ferrite beads, and fuses. When these components are enclosed by the remote sense connections they are effectively placed inside the regulation control loop, which can adversely affect the stability of the regulator.*

### Capacitor Recommendations for the PT6360 Series of Integrated Switching Regulators

#### Input Capacitor:

The recommended input capacitance is determined by 1.3-A minimum ripple current rating and 560  $\mu$ F minimum capacitance.

Ripple current and  $<100$  m $\Omega$  equivalent series resistance (ESR) values are the major considerations, along with temperature, when designing with different types of capacitors. Tantalum capacitors have a recommended minimum voltage rating of  $2 \times$  (max. dc voltage + ac ripple). This is necessary to insure reliability for input voltage bus applications.

#### Output Capacitors:

The recommended ESR of the output capacitor is 150m $\Omega$ . Electrolytic capacitors have marginal ripple performance at frequencies greater than 400kHz but excellent low frequency transient response. Above the ripple frequency, ceramic capacitors are necessary to improve the transient response and reduce any high frequency noise components apparent during higher current excursions. Preferred low ESR type capacitor part numbers are identified in Table 2-1.

#### Tantalum Capacitors

Tantalum type capacitors can be used for the output but only the AVX TPS, Sprague 593D/594/595 or Kemet T495/T510 series. These capacitors are recommended over many other tantalum types due to their higher rated surge, power dissipation, and ripple current capability. As a caution the TAJ series by AVX is not recommended. This series has considerably higher ESR, reduced power dissipation, and lower ripple current capability. The TAJ series is less reliable than the AVX TPS series when determining power dissipation capability. Tantalum or Oscon® types are recommended for applications where ambient temperatures fall below 0 °C.

#### Capacitor Table

Table 2-1 identifies the characteristics of capacitors from a number of vendors with acceptable ESR and ripple current (rms) ratings. The number of capacitors required at both the input and output buses is identified for each capacitor type.

*This is not an extensive capacitor list. Capacitors from other vendors are available with comparable specifications. Those listed are for guidance. The RMS ripple current rating and ESR (Equivalent Series Resistance at 100 kHz) are critical parameters necessary to insure both optimum regulator performance and long capacitor life.*

**Table 2-1: Input/Output Capacitors**

Capacitor Vendor/ Series	Capacitor Characteristics					Quantity		Vendor Part Number
	Working Voltage	Value ( $\mu$ F)	(ESR) Equivalent Series Resistance	105 °C Maximum Ripple Current (I <sub>rms</sub> )	Physical Size (mm)	Input Bus	Output Bus	
Panasonic FC (Radial)	35 V	680	0.043 $\Omega$	1655 mA	12.5x20	1	1	EEUFC1V681
	25 V	330	0.090 $\Omega$	755 mA	10x12.5	N/R (1)	1	EEUFC1E331
	25 V	1000	0.038 $\Omega$	1690mA	16x15	1	1	EEUFC1E102S
FC/FK (Surface Mtg)	50 V	1000	0073 $\Omega$	1610 mA	16x16.5	1	1	EEVFK1H102M
	35 V	680	0.060 $\Omega$	1100 mA	12.5x13.5	1 (2)	1	EEVFK1V681Q (V <sub>o</sub> <2.6 V)
United Chemi-con LXZ/LXV Series MVY (Surface Mtg)	35 V	680	0.037 $\Omega$	1660 mA	12.5x20	1	1	LXZ35VB681M12X20LL
	35 V	680	0.068 $\Omega$	1050 mA	10x16	1 (2)	1	LXV35VB102M16X20LL (V <sub>o</sub> <2.6 V)
	25 V	330	0.15 $\Omega$	670 mA	10x10.3	N/R (1)	1	MVY25VC331M10X10TP
Nichicon PM Series	35 V	560	0.048 $\Omega$	1360 mA	16x15	1	1	UPM1V561MHH6
	25 V	1200	0.039 $\Omega$	1400 mA	16x15	1	1	UPM1E122MHH6
	35 V	820	0.038 $\Omega$	1370 mA	18x15	1	1	UPM1V821MHH6
Os-con: SS SVP (surface Mount) Old SV Series	10 V	330	0.025 $\Omega$	3500 mA	10x10.5	N/R (1)	1	10SS330M (V <sub>o</sub> <5.1 V)
	16 V	330	0.016 $\Omega$	4700 mA	11x12	2	1	16SVP330M
AVX Tantalum TPS (Surface Mtgt)	10 V	330	0.1 $\Omega$	>2500 mA	7.3L	N/R (1)	1	TPSE337M010R0100 (V <sub>o</sub> <5.1 V)
	10 V	330	0.06 $\Omega$	>3000 mA	$\times$ 5.7W $\times$ 4.1H	N/R (1)	1	TPSV337M010R0060 (V <sub>o</sub> <5.1 V)
Kemet Tantalum T520/T495 Series (Surface Mount)	10 V	330	0.040 $\Omega$	1600 mA	4.3W	N/R (1)	1	520X337M010AS
	6.3 V	220	0.07 $\Omega$	>2000 mA	$\times$ 7.3L $\times$ 4.0H	N/R (1)	1	T495X227M0100AS
Sprague Tantalum 594D Series (Surface Mount)	10 V	330	0.045 $\Omega$	2360 mA	7.2L $\times$ 6W $\times$ 4.1H	N/R (1)	1	594D337X0010R2T

(1) N/R –Not recommended. The voltage rating does not meet the minimum operating limits.

(2) Recommended Input capacitor when V<sub>o</sub><2.6 V; lower RMS mA required .

### Adjusting the Output Voltage of the PT6360 Series of Integrated Switching Regulators

The output voltage of the PT6360 series of power modules may be adjusted higher or lower than the pre-set voltage with the addition of a single external resistor. Table 3-1 gives the allowable adjustment range for each model of the series as  $V_a$  (min) and  $V_a$  (max). The value of the external resistor can either be calculated using the formulas given below, or simply selected from the range of values given in Table 3-2. Refer to Figure 3-1 for the placement of the required resistor. Use the resistor  $R_1$  to adjust up, and the resistor ( $R_2$ ) to down.

**Adjust Up:** An increase in the output voltage is obtained by adding a resistor  $R_2$ , between  $V_o$  *adjust* (pin 12) and *GND* (pins 5-8).

**Adjust Down:** Add a resistor ( $R_1$ ), between  $V_o$  *adjust* (pin 12) and (+)Sense (pin 11).

**Figure 3-1**

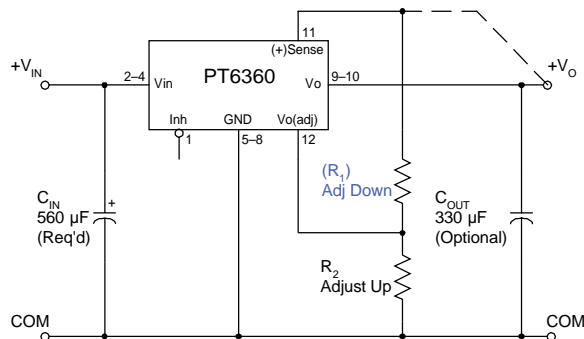

**Table 3-1**

ISR OUTPUT VOLTAGE ADJUSTMENT RANGE AND FORMULA PARAMETERS							
Series Pt. No.	PT6361	PT6362	PT6363	PT6364	PT6365	PT6366	PT6367
<b><math>V_o</math> (nom)</b>	5.0 V	3.3 V	2.5 V	1.8 V	1.5 V	1.2 V	1.0 V
<b><math>V_a</math> (min)</b>	3.35 V	2.6 V	2.0 V	1.52 V	1.31 V	1.1 V	0.95 V
<b><math>V_a</math> (max)</b>	5.5 V	3.63 V	2.8 V	2.1 V	1.82 V	1.52 V	1.32 V
<b><math>R_o</math> (k<math>\Omega</math>)</b>	10.0	10.2	10.7	10.2	9.76	10.0	10.2
<b><math>R_s</math> (k<math>\Omega</math>)</b>	15.0	24.9	24.9	24.9	24.9	24.9	24.9

The values of ( $R_1$ ) [adjust down], and  $R_2$  [adjust up], can be calculated using the following formulas. Refer to Figure 3-1 for the placement of the required resistor; either ( $R_1$ ) or  $R_2$  as appropriate.

$$(R_1) = \frac{R_o (V_a - 0.8)}{V_o - V_a} - R_s \quad \text{k}\Omega$$

$$R_2 = \frac{0.8 R_o}{V_a - V_o} - R_s \quad \text{k}\Omega$$

Where:  $V_o$  = Original output voltage  
 $V_a$  = Adjusted output voltage  
 $R_o$  = The resistance value from Table 3-1  
 $R_s$  = The series resistance from Table 3-1

**Notes:**

1. Use a 1% (or better) tolerance resistor in either the ( $R_1$ ) or  $R_2$  location. Place the resistor as close to the ISR as possible.
2. Never connect capacitors from  $V_o$  *Adjust* to either *GND* or  $V_{out}$ . Any capacitance added to the  $V_o$  *Adjust* pin will affect the stability of the ISR.
3. If the remote sense feature is not being used, the adjust resistor ( $R_1$ ) can also be connected to  $V_{out}$ , (pins 9-10) instead of (+)Sense.

PT6360 Series

Table 3-2

ISR ADJUSTMENT RESISTOR VALUES

Series Pt. No.	PT6361	PT6362	PT6363	PT6364	PT6365	PT6366	PT6367
V <sub>o</sub> (nom)	5.0 V	3.3 V	2.5 V	1.8 V	1.5 V	1.2 V	1.0 V
<b>V<sub>a</sub> (req.d)</b>			<b>V<sub>a</sub> (req.d)</b>				
5.50	1.0 kΩ		2.800	3.6 kΩ			
5.40	5.0 kΩ		2.750	9.3 kΩ			
5.30	11.7 kΩ		2.700	17.9 kΩ			
5.20	25.0 kΩ		2.650	32.2 kΩ			
5.10	65.0 kΩ		2.600	60.7 kΩ			
5.00			2.550	146.0 kΩ			
4.90	(395.0) kΩ		2.500				
4.80	(185.0) kΩ		2.450	(328.0) kΩ			
4.70	(115.0) kΩ		2.400	(146.0) kΩ			
4.60	(80.0) kΩ		2.350	(85.7) kΩ			
4.50	(59.0) kΩ		2.300	(55.3) kΩ			
4.40	(45.0) kΩ		2.250	(37.2) kΩ			
4.30	(35.0) kΩ		2.200	(25.0) kΩ			
4.20	(27.5) kΩ		2.150	(16.4) kΩ			
4.10	(21.7) kΩ		2.100	(9.9) kΩ	2.3 kΩ		
4.00	(17.0) kΩ		2.050	(4.8) kΩ	7.7 kΩ		
3.90	(13.2) kΩ		2.000	(0.8) kΩ	15.9 kΩ		
3.80	(10.0) kΩ		1.950		29.5 kΩ		
3.70	(7.3) kΩ		1.900		56.7 kΩ		
3.60	(5.0) kΩ	2.3 kΩ	1.850	138.0 kΩ			
3.55	(4.0) kΩ	7.7 kΩ	1.800		1.1 kΩ		
3.50	(3.0) kΩ	15.9 kΩ	1.750	(169.0) kΩ	6.3 kΩ		
3.45	(2.1) kΩ	29.5 kΩ	1.700	(66.9) kΩ	14.1 kΩ		
3.40	(1.3) kΩ	56.7 kΩ	1.650	(32.9) kΩ	27.2 kΩ		
3.35	(0.5) kΩ	138.0 kΩ	1.600	(15.9) kΩ	53.2 kΩ		
3.30			1.550	(5.7) kΩ	131.0 kΩ		
3.25		(475.0) kΩ	1.500			1.8 kΩ	
3.20		(220.0) kΩ	1.475		(239.0) kΩ	4.2 kΩ	
3.15		(135.0) kΩ	1.450		(102.0) kΩ	7.1 kΩ	
3.10		(92.4) kΩ	1.425		(56.4) kΩ	10.7 kΩ	
3.05		(66.9) kΩ	1.400		(33.7) kΩ	15.1 kΩ	
3.00		(49.9) kΩ	1.375		(20.0) kΩ	20.8 kΩ	
2.95		(37.5) kΩ	1.350		(10.9) kΩ	28.4 kΩ	
2.90		(28.6) kΩ	1.325		(4.4) kΩ	39.1 kΩ	
2.85		(21.6) kΩ	1.300			55.1 kΩ	2.3 kΩ
2.80		(15.9) kΩ	1.275			81.8 kΩ	4.8 kΩ
2.75		(11.3) kΩ	1.250			135.0 kΩ	7.7 kΩ
2.70		(7.4) kΩ	1.225			295.0 kΩ	11.4 kΩ
2.65		(4.1) kΩ	1.200				15.9 kΩ
2.60		(1.3) kΩ	1.175			(125.0) kΩ	21.7 kΩ
			1.150			(45.1) kΩ	29.5 kΩ
			1.125			(18.4) kΩ	40.4 kΩ
			1.100			(5.1) kΩ	56.7 kΩ
			1.075				83.9 kΩ
			1.050				138.0 kΩ
			1.025				302.0 kΩ
			1.000				
			0.975				(46.5) kΩ
			0.950				(5.7) kΩ

R<sub>1</sub> = (Blue) R<sub>2</sub> = Black

### Using the Inhibit Control of the PT6360 Series of Integrated Switching Regulators

The PT6360 series of integrated switching regulators (ISRs) provide step-down voltage conversion for output loads of up to 11 A. For applications that require the output voltage to be held off, these ISRs incorporate an *Inhibit*\* control (pin 1). The *Inhibit*\* control input can be used for power-up sequencing or whenever there is a requirement for the output voltage from the ISR to be turned off.

The ISR functions normally with pin 1 open circuit, providing a regulated output whenever a valid source voltage is applied between  $V_{in}$  (pins 2–3) and  $GND$  (pins 5–8). When a low-level ground signal is applied to pin 1, the regulator output is turned off<sup>2</sup> and the input current is significantly reduced<sup>4</sup>.

Figure 4-1 shows the typical application of the *Inhibit*\* function. Note the discrete transistor,  $Q_1$ . The *Inhibit*\* control has its own internal pull-up to  $V_{in}$  potential. An open-collector or open-drain device is recommended to control this input<sup>1</sup>. The voltage thresholds are given in Table 4-1.

**Table 4-1; Inhibit Control Requirements**

Parameter	Min	Typ	Max
Enable ( $V_{IH}$ )	2.0 V	—	$V_{in}$
Disable ( $V_{IL}$ )	-0.1 V	—	+0.3 V
$I_{IL}$	—	-0.5 mA	—

**Figure 4-1**

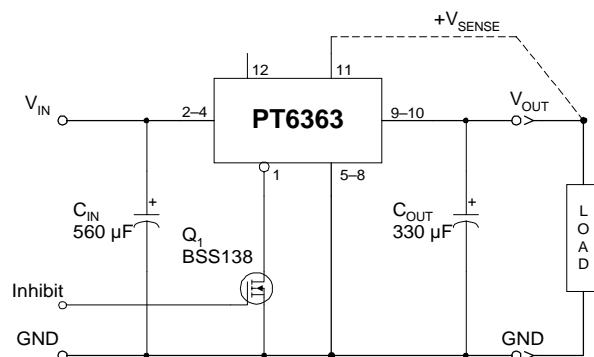

**Turn-On Time:** In the circuit of Figure 4-1, turning  $Q_1$  on applies a low-voltage to the *Inhibit*\* control (pin 1) and disables the output of the regulator<sup>2</sup>. If  $Q_1$  is then turned off, the ISR executes a soft-start power up<sup>3</sup>. Power up consists of a short delay (approx. 10 msec), followed by a period in which the output voltage rises to the full regulation voltage. The module produces a regulated output voltage in approximately 15 msec. Figure 4-2 shows the rise in both the output voltage and input current for a PT6363 (2.5 V), following the turn-off of  $Q_1$ . The turn off of  $Q_1$  corresponds to the rise in the waveform,  $Q_1 V_{ds}$ . The waveforms were measured with a 12 VDC input voltage, and 8.3-A load.

**Figure 4-2**

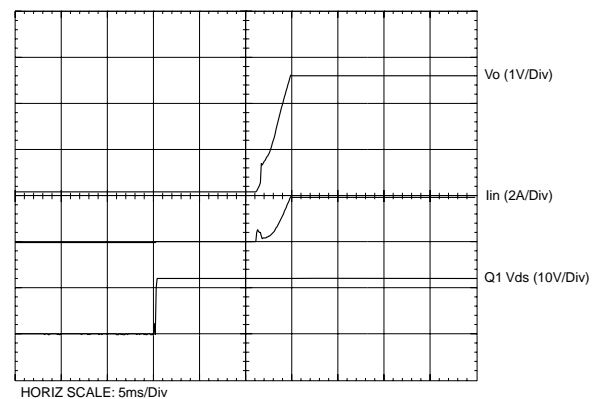

**Notes:**

1. Use an open-collector device with a breakdown voltage of at least 20 V (preferably a discrete transistor) for the *Inhibit*\* input. A pull-up resistor is not necessary. To disable the output voltage the control pin should be pulled low to less than +0.6 VDC.
2. When a ground signal is applied to the *Inhibit*\* control (pin 1) the module output is effectively turned off (tri-state). The output voltage decays to zero as the load impedance discharges the output capacitors.
3. When a ground signal to the *Inhibit*\* pin is removed, the regulator output initiates a soft-start cycle by first asserting a low impedance to ground. If an external voltage is applied to the regulator output it will sink current and possibly overstress the module.
4. When a ground signal is applied to the *Inhibit*\* pin, the module is effectively turned off and the input current is reduced to about 0.5 mA.

**PACKAGING INFORMATION**

Orderable Device	Status <sup>(1)</sup>	Package Type	Package Drawing	Pins	Package Qty	Eco Plan <sup>(2)</sup>	Lead/Ball Finish	MSL Peak Temp <sup>(3)</sup>
PT6361A	ACTIVE	SIP MOD ULE	EPJ	12	21	TBD	Call TI	Level-1-215C-UNLIM
PT6361C	ACTIVE	SIP MOD ULE	EPK	12	21	TBD	Call TI	Level-3-215C-168HRS
PT6361N	ACTIVE	SIP MOD ULE	EPH	12	21	TBD	Call TI	Level-1-215C-UNLIM
PT6362A	ACTIVE	SIP MOD ULE	EPJ	12	21	TBD	Call TI	Level-1-215C-UNLIM
PT6362C	ACTIVE	SIP MOD ULE	EPK	12	21	TBD	Call TI	Level-3-215C-168HRS
PT6362N	ACTIVE	SIP MOD ULE	EPH	12	21	TBD	Call TI	Level-1-215C-UNLIM
PT6364N	ACTIVE	SIP MOD ULE	EPH	12	21	TBD	Call TI	Level-1-215C-UNLIM

<sup>(1)</sup> The marketing status values are defined as follows:

**ACTIVE:** Product device recommended for new designs.

**LIFEBUY:** TI has announced that the device will be discontinued, and a lifetime-buy period is in effect.

**NRND:** Not recommended for new designs. Device is in production to support existing customers, but TI does not recommend using this part in a new design.

**PREVIEW:** Device has been announced but is not in production. Samples may or may not be available.

**OBSOLETE:** TI has discontinued the production of the device.

<sup>(2)</sup> Eco Plan - The planned eco-friendly classification: Pb-Free (RoHS), Pb-Free (RoHS Exempt), or Green (RoHS & no Sb/Br) - please check <http://www.ti.com/productcontent> for the latest availability information and additional product content details.

**TBD:** The Pb-Free/Green conversion plan has not been defined.

**Pb-Free (RoHS):** TI's terms "Lead-Free" or "Pb-Free" mean semiconductor products that are compatible with the current RoHS requirements for all 6 substances, including the requirement that lead not exceed 0.1% by weight in homogeneous materials. Where designed to be soldered at high temperatures, TI Pb-Free products are suitable for use in specified lead-free processes.

**Pb-Free (RoHS Exempt):** This component has a RoHS exemption for either 1) lead-based flip-chip solder bumps used between the die and package, or 2) lead-based die adhesive used between the die and leadframe. The component is otherwise considered Pb-Free (RoHS compatible) as defined above.

**Green (RoHS & no Sb/Br):** TI defines "Green" to mean Pb-Free (RoHS compatible), and free of Bromine (Br) and Antimony (Sb) based flame retardants (Br or Sb do not exceed 0.1% by weight in homogeneous material)

<sup>(3)</sup> MSL, Peak Temp. -- The Moisture Sensitivity Level rating according to the JEDEC industry standard classifications, and peak solder temperature.

**Important Information and Disclaimer:**The information provided on this page represents TI's knowledge and belief as of the date that it is provided. TI bases its knowledge and belief on information provided by third parties, and makes no representation or warranty as to the accuracy of such information. Efforts are underway to better integrate information from third parties. TI has taken and continues to take reasonable steps to provide representative and accurate information but may not have conducted destructive testing or chemical analysis on incoming materials and chemicals. TI and TI suppliers consider certain information to be proprietary, and thus CAS numbers and other limited information may not be available for release.

In no event shall TI's liability arising out of such information exceed the total purchase price of the TI part(s) at issue in this document sold by TI to Customer on an annual basis.

EPK (R-MSIP-G12)

METAL SINGLE-IN-LINE MODULE

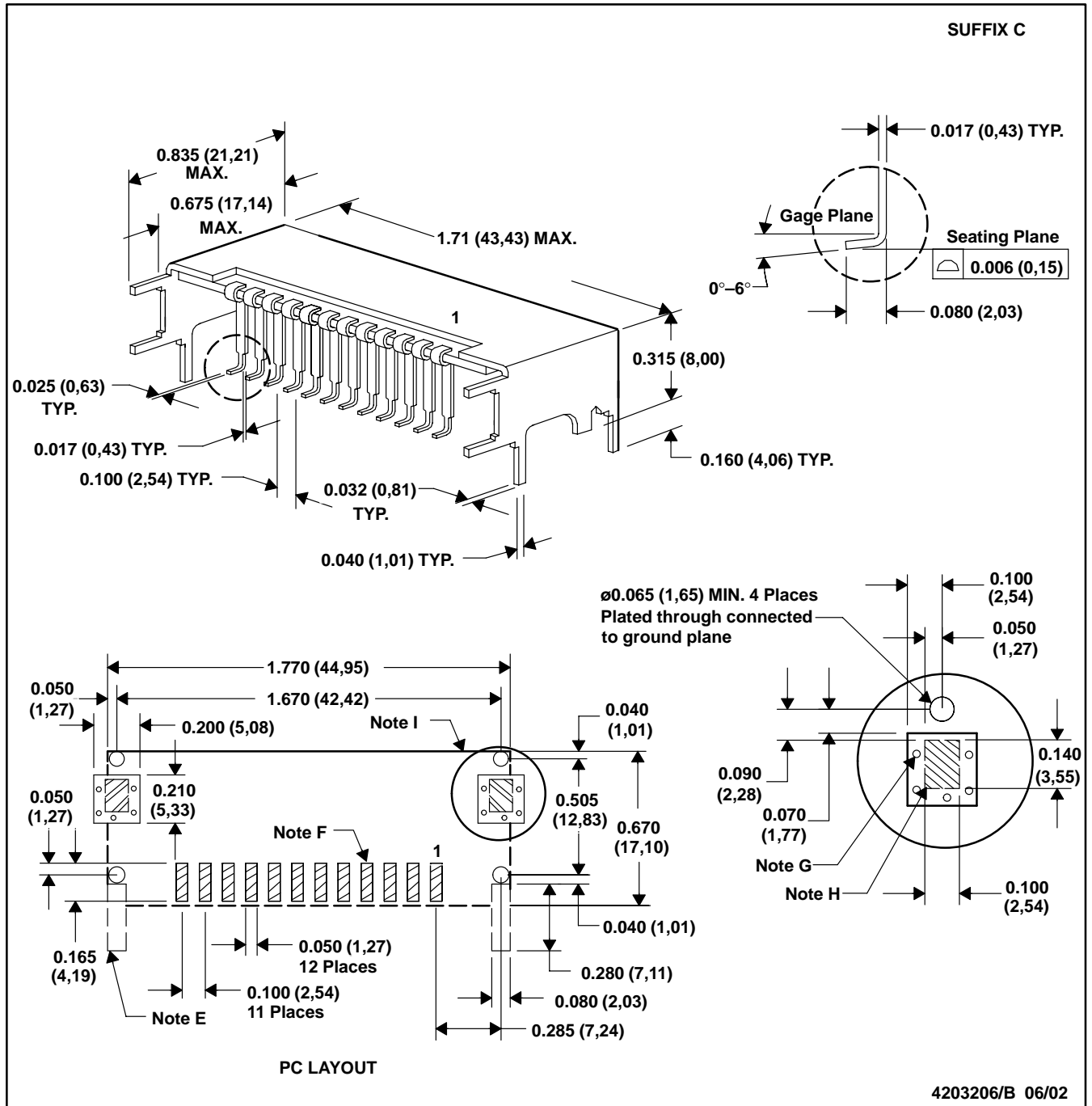

- NOTES: A. All linear dimensions are in inches (mm).  
 B. This drawing is subject to change without notice.  
 C. 2 place decimals are  $\pm 0.030$  ( $\pm 0,76$  mm).  
 D. 3 place decimals are  $\pm 0.010$  ( $\pm 0,25$  mm).  
 E. Recommended mechanical keep-out area.  
 F. Power pin connections should utilize two or more vias per input, ground and output pin.

- G. Vias are recommended to improve copper adhesion.  
 H. Solder mask openings to copper island for solder joints to mechanical pins. Electrically connect case to ground plane.  
 I. Case outline reference.

EPJ (R-MSIP-G12)

METAL SINGLE-IN-LINE MODULE

Suffix A

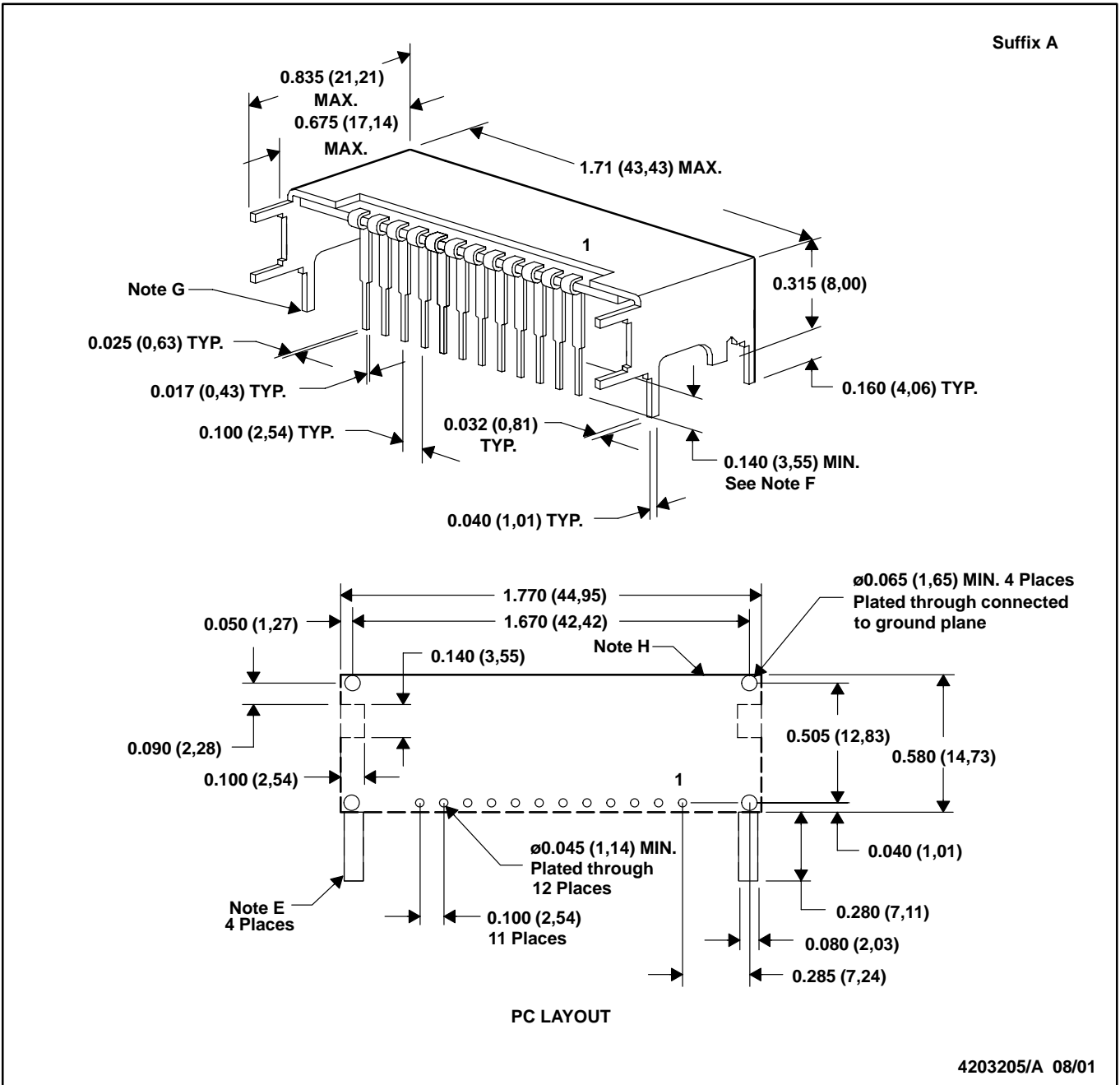

- NOTES: A. All linear dimensions are in inches (mm).  
 B. This drawing is subject to change without notice.  
 C. 2 place decimals are  $\pm 0.030$  ( $\pm 0,76$  mm).  
 D. 3 place decimals are  $\pm 0.010$  ( $\pm 0,25$  mm).  
 E. Recommended mechanical keep-out area.  
 F. Electrical pin length mounted on circuit board seating plane to pin end.  
 G. Electrically connect case to ground plane.  
 H. Case outline reference.

EPH (R-MSIP-T12)

METAL SINGLE-IN-LINE MODULE

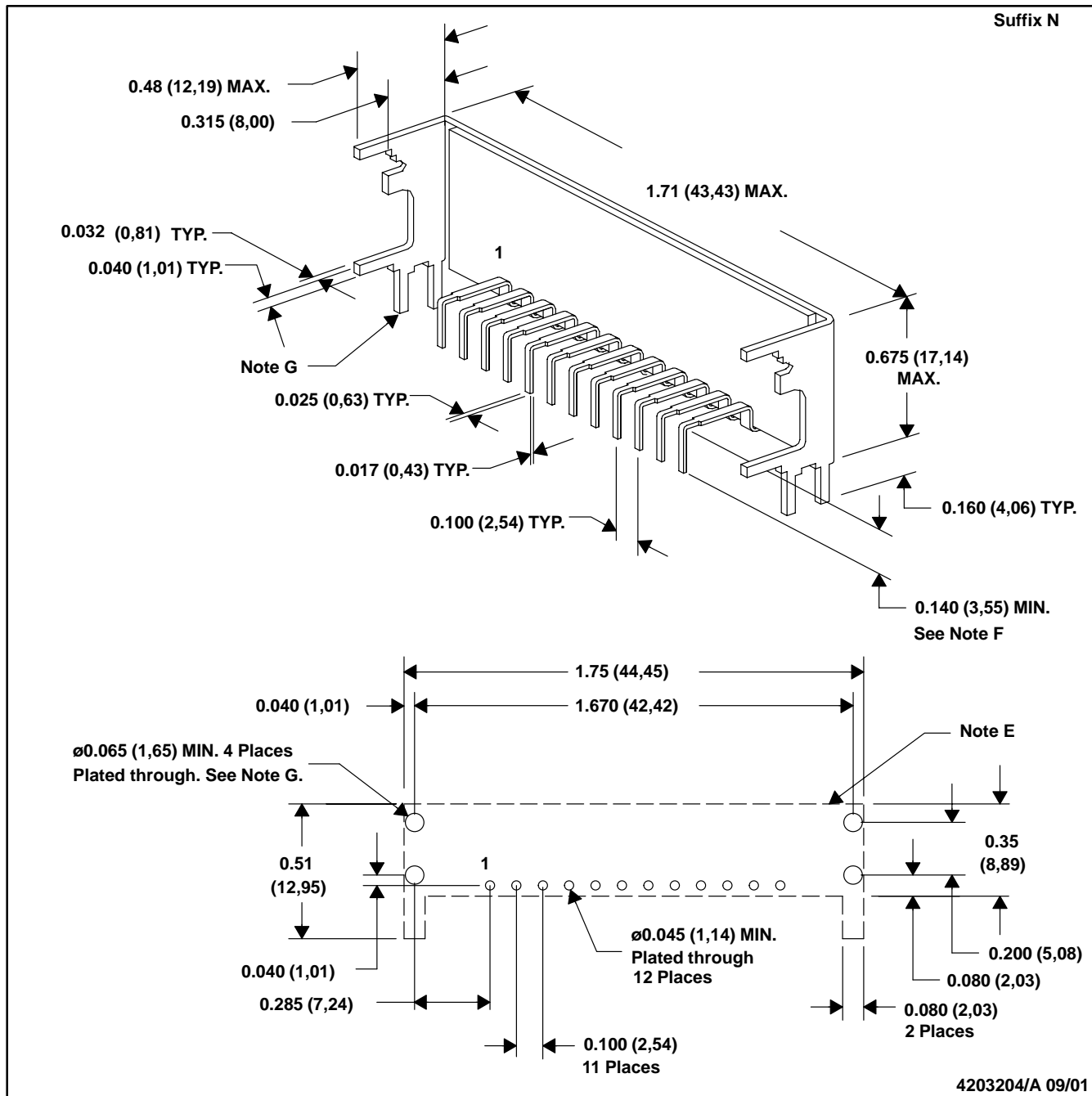

- NOTES: A. All linear dimensions are in inches (mm).  
 B. This drawing is subject to change without notice.  
 C. 2 place decimals are  $\pm 0.030$  ( $\pm 0,76$ mm).  
 D. 3 place decimals are  $\pm 0.010$  ( $\pm 0,25$ mm).  
 E. Recommended mechanical keep out area.  
 F. Electrical pin length mounted on circuit board seating plane to pin end.  
 G. Electrically connect case to ground plane.

## IMPORTANT NOTICE

Texas Instruments Incorporated and its subsidiaries (TI) reserve the right to make corrections, modifications, enhancements, improvements, and other changes to its products and services at any time and to discontinue any product or service without notice. Customers should obtain the latest relevant information before placing orders and should verify that such information is current and complete. All products are sold subject to TI's terms and conditions of sale supplied at the time of order acknowledgment.

TI warrants performance of its hardware products to the specifications applicable at the time of sale in accordance with TI's standard warranty. Testing and other quality control techniques are used to the extent TI deems necessary to support this warranty. Except where mandated by government requirements, testing of all parameters of each product is not necessarily performed.

TI assumes no liability for applications assistance or customer product design. Customers are responsible for their products and applications using TI components. To minimize the risks associated with customer products and applications, customers should provide adequate design and operating safeguards.

TI does not warrant or represent that any license, either express or implied, is granted under any TI patent right, copyright, mask work right, or other TI intellectual property right relating to any combination, machine, or process in which TI products or services are used. Information published by TI regarding third-party products or services does not constitute a license from TI to use such products or services or a warranty or endorsement thereof. Use of such information may require a license from a third party under the patents or other intellectual property of the third party, or a license from TI under the patents or other intellectual property of TI.

Reproduction of information in TI data books or data sheets is permissible only if reproduction is without alteration and is accompanied by all associated warranties, conditions, limitations, and notices. Reproduction of this information with alteration is an unfair and deceptive business practice. TI is not responsible or liable for such altered documentation.

Resale of TI products or services with statements different from or beyond the parameters stated by TI for that product or service voids all express and any implied warranties for the associated TI product or service and is an unfair and deceptive business practice. TI is not responsible or liable for any such statements.

Following are URLs where you can obtain information on other Texas Instruments products and application solutions:

<b>Products</b>		<b>Applications</b>	
Amplifiers	<a href="http://amplifier.ti.com">amplifier.ti.com</a>	Audio	<a href="http://www.ti.com/audio">www.ti.com/audio</a>
Data Converters	<a href="http://dataconverter.ti.com">dataconverter.ti.com</a>	Automotive	<a href="http://www.ti.com/automotive">www.ti.com/automotive</a>
DSP	<a href="http://dsp.ti.com">dsp.ti.com</a>	Broadband	<a href="http://www.ti.com/broadband">www.ti.com/broadband</a>
Interface	<a href="http://interface.ti.com">interface.ti.com</a>	Digital Control	<a href="http://www.ti.com/digitalcontrol">www.ti.com/digitalcontrol</a>
Logic	<a href="http://logic.ti.com">logic.ti.com</a>	Military	<a href="http://www.ti.com/military">www.ti.com/military</a>
Power Mgmt	<a href="http://power.ti.com">power.ti.com</a>	Optical Networking	<a href="http://www.ti.com/opticalnetwork">www.ti.com/opticalnetwork</a>
Microcontrollers	<a href="http://microcontroller.ti.com">microcontroller.ti.com</a>	Security	<a href="http://www.ti.com/security">www.ti.com/security</a>
Low Power Wireless	<a href="http://www.ti.com/lpw">www.ti.com/lpw</a>	Telephony	<a href="http://www.ti.com/telephony">www.ti.com/telephony</a>
		Video & Imaging	<a href="http://www.ti.com/video">www.ti.com/video</a>
		Wireless	<a href="http://www.ti.com/wireless">www.ti.com/wireless</a>

Mailing Address: Texas Instruments  
Post Office Box 655303 Dallas, Texas 75265