

- High Efficiency > 85%
- Self-Contained Inductor
- Short Circuit Protection
- Over-Temperature Protection

The PT79SR100 is a line of Negative Input/Negative Output 3-terminal Integrated Switching

Regulators (ISRs). These ISRs have a maximum output current of -1.5 Amps and an output voltage that is laser trimmed to most industry standard voltages. They have excellent line and load regulation, and are ideal for applications, such as RS232 and Ethernet communications, ECL logic, and op-amp circuitry.

Standard Application

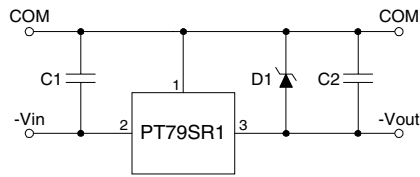

C1 = Optional ceramic (1 μ F)
C2 = Optional ceramic (1-5 μ F)
D1 = Zener diode required to clamp turn-on overshoot (See Application Note)

Pin-Out Information

Pin	Function
1	GND
2	$-V_{in}$
3	$-V_{out}$

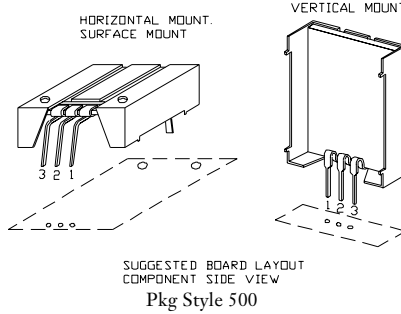

Ordering Information

PT79SR1	XX	Y
Output Voltage		Package Suffix
05 = -5.0 Volts		V = Vertical Mount
52 = -5.2 Volts		S = Surface Mount
06 = -6.0 Volts		H = Horizontal Mount
08 = -8.0 Volts		
09 = -9.0 Volts		
12 = -12.0 Volts		
15 = -15.0 Volts		

Specifications

Characteristics ($T_a = 25^\circ\text{C}$ unless noted)	Symbols	Conditions	PT79SR100 SERIES			
			Min	Typ	Max	Units
Output Current	I_o	Over V_{in} range	-0.1*	—	-1.5	A
Short Circuit Current	I_{sc}	$V_{in} = V_o - 4V$	—	-3.5	—	Apk
Input Voltage Range	V_{in}	$I_o = -0.1$ to -1.5 A $-0.1 \geq I_o \geq -1.5$ A	$V_o = -5V$ $V_o = -15V$	-9 -19	— -30	V V
Output Voltage Tolerance	ΔV_o	Over V_{in} range, $I_o = -1.5$ A $T_a = 20^\circ\text{C}$ to shutdown	—	± 1.0	± 3.0	% V_o
Line Regulation	Reg_{line}	Over V_{in} range	—	± 1.0	± 2.0	% V_o
Load Regulation	Reg_{load}	$-0.1 \leq I_o \leq -1.5$ A	—	± 0.5	± 1.0	% V_o
V_o Ripple/Noise	V_n	$V_{in} = -15V$, $I_o = -1.0$ A, $V_o = -5V$	—	35	—	mV _{pp}
Transient Response	t_{tr}	50% load change $V_o = \text{overshoot/undershoot}$	—	100 30	—	μSec % V_o
Efficiency	η	$V_{in} = -10V$, $I_o = -1.0$ A, $V_o = -5V$	—	85	—	%
Switching Frequency	f_o	Over V_{in} and I_o ranges	0.95	1.0	1.05	MHz
Absolute Maximum Operating Temperature Range	T_a		-40	—	+85	$^\circ\text{C}$
Recommended Operating Temperature Range	T_a	Free Air Convection, (40-60LFM) Over V_{in} and I_o ranges	-40	—	+60**	$^\circ\text{C}$
Thermal Resistance	θ_{ja}	Free Air Convection, (40-60LFM)	—	45	—	$^\circ\text{C}/W$
Temperature Coefficient	T_c	Over V_{in} and I_o ranges	—	± 0.5	± 1.5	mV/ $^\circ\text{C}$
Storage Temperature	T_s		-40	—	+125	$^\circ\text{C}$
Mechanical Shock	—	Per Mil-STD-883D, Method 2002.3	—	500	—	G's
Mechanical Vibration	—	Per Mil-STD-883D, Method 2007.2, 20-2000 Hz, soldered in a PC board	—	5	—	G's
Weight	—		—	7.0	—	Grams

* ISR will operate down to no load with reduced specifications.

** See Thermal Derating chart.

**-1.5 Amp Negative Step-Down
Integrated Switching Regulator**

PT79SR105, -5.0 VDC (See Note 1)

Efficiency vs Output Current

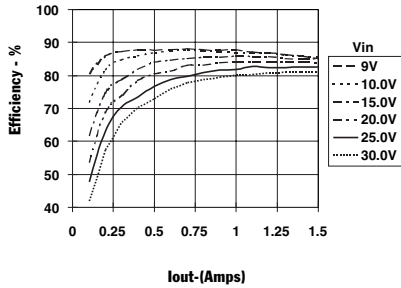

Ripple vs Output Current

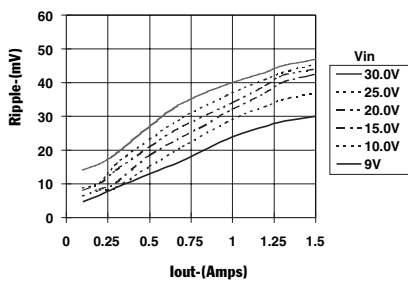

Thermal Derating (T_a) (See Note 2)

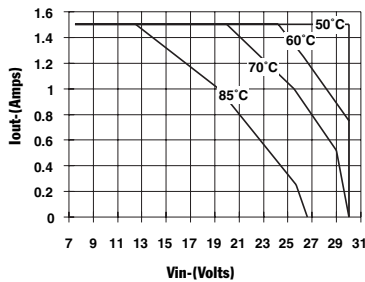

Power Dissipation vs Output Current

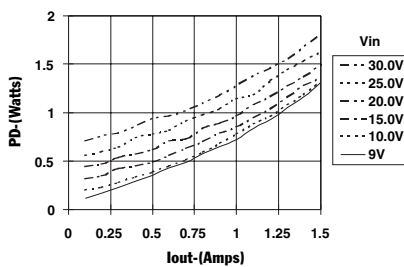

PT79SR112, -12.0 VDC (See Note 1)

Efficiency vs Output Current

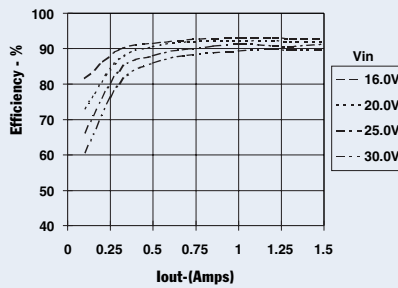

Ripple vs Output Current

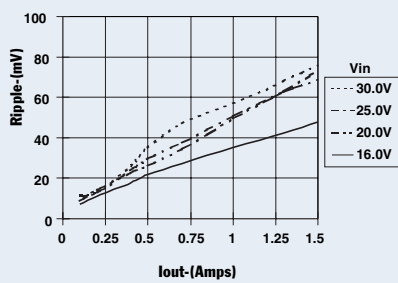

Thermal Derating (T_a) (See Note 2)

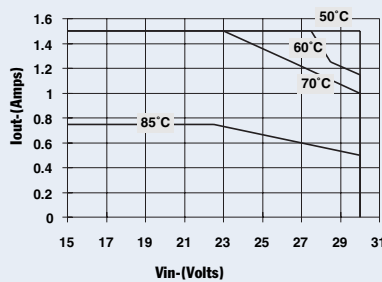

Power Dissipation vs Output Current

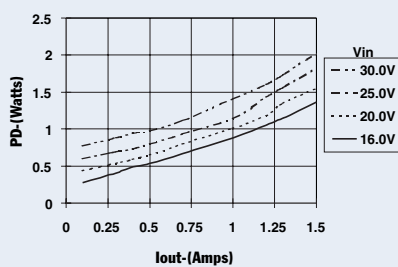

PT79SR115, -15.0 VDC (See Note 1)

Efficiency vs Output Current

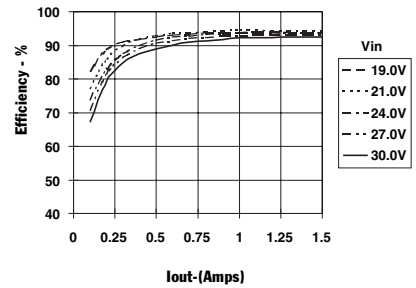

Ripple vs Output Current

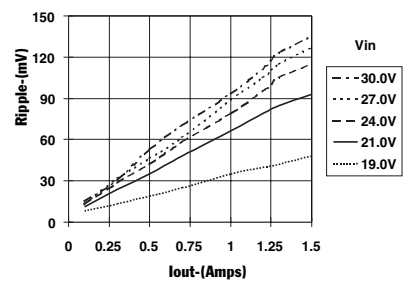

Thermal Derating (T_a) (See Note 2)

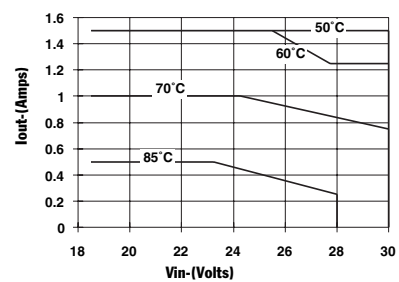

Power Dissipation vs Output Current

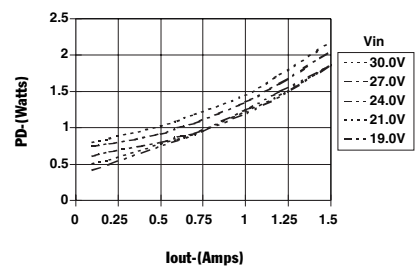

Note 1: All data listed in the above graphs, except for derating data, has been developed from actual products tested at 25°C. This data is considered typical data for the ISR.
Note 2: Thermal derating graphs are developed in free air convection cooling of 40-60 LFM soldered in a printed circuit board. (See Thermal Application Notes.)

PACKAGING INFORMATION

Orderable Device	Status ⁽¹⁾	Package Type	Package Drawing	Pins	Package Qty	Eco Plan ⁽²⁾	Lead/Ball Finish	MSL Peak Temp ⁽³⁾
PT79SR105H	ACTIVE	SIP MOD ULE	EFA	3	25	Pb-Free (RoHS)	Call TI	N / A for Pkg Type
PT79SR105S	ACTIVE	SIP MOD ULE	EFC	3	25	Pb-Free (RoHS)	Call TI	Level-1-215C-UNLIM
PT79SR105T	ACTIVE	SIP MOD ULE	EFT	3	25	Pb-Free (RoHS)	Call TI	Level-1-215C-UNLIM
PT79SR105V	ACTIVE	SIP MOD ULE	EFD	3	25	Pb-Free (RoHS)	Call TI	N / A for Pkg Type
PT79SR106S	ACTIVE	SIP MOD ULE	EFC	3	25	Pb-Free (RoHS)	Call TI	N / A for Pkg Type
PT79SR108H	ACTIVE	SIP MOD ULE	EFA	3	25	Pb-Free (RoHS)	Call TI	N / A for Pkg Type
PT79SR108S	ACTIVE	SIP MOD ULE	EFC	3	25	Pb-Free (RoHS)	Call TI	Level-1-215C-UNLIM
PT79SR108V	ACTIVE	SIP MOD ULE	EFD	3	25	Pb-Free (RoHS)	Call TI	N / A for Pkg Type
PT79SR109H	ACTIVE	SIP MOD ULE	EFA	3	25	Pb-Free (RoHS)	Call TI	N / A for Pkg Type
PT79SR109S	ACTIVE	SIP MOD ULE	EFC	3	25	Pb-Free (RoHS)	Call TI	Level-1-215C-UNLIM
PT79SR112H	ACTIVE	SIP MOD ULE	EFA	3	25	Pb-Free (RoHS)	Call TI	N / A for Pkg Type
PT79SR112S	ACTIVE	SIP MOD ULE	EFC	3	25	Pb-Free (RoHS)	Call TI	Level-1-215C-UNLIM
PT79SR112T	ACTIVE	SIP MOD ULE	EFT	3	25	Pb-Free (RoHS)	Call TI	N / A for Pkg Type
PT79SR112V	ACTIVE	SIP MOD ULE	EFD	3	25	Pb-Free (RoHS)	Call TI	N / A for Pkg Type
PT79SR115H	ACTIVE	SIP MOD ULE	EFA	3	25	Pb-Free (RoHS)	Call TI	N / A for Pkg Type
PT79SR115S	ACTIVE	SIP MOD ULE	EFC	3	25	Pb-Free (RoHS)	Call TI	Level-1-215C-UNLIM
PT79SR115T	ACTIVE	SIP MOD ULE	EFT	3	25	Pb-Free (RoHS)	Call TI	N / A for Pkg Type
PT79SR115V	ACTIVE	SIP MOD ULE	EFD	3	25	Pb-Free (RoHS)	Call TI	N / A for Pkg Type
PT79SR152H	ACTIVE	SIP MOD ULE	EFA	3	25	Pb-Free (RoHS)	Call TI	Level-1-215C-UNLIM
PT79SR152S	ACTIVE	SIP MOD ULE	EFC	3	25	Pb-Free (RoHS)	Call TI	Level-1-215C-UNLIM
PT79SR152ST	ACTIVE	SIP MOD ULE	EFC	3	200	Pb-Free (RoHS)	Call TI	Level-1-215C-UNLIM
PT79SR152V	ACTIVE	SIP MOD ULE	EFD	3	25	Pb-Free (RoHS)	Call TI	Level-1-215C-UNLIM

⁽¹⁾ The marketing status values are defined as follows:

ACTIVE: Product device recommended for new designs.

LIFEBUY: TI has announced that the device will be discontinued, and a lifetime-buy period is in effect.

NRND: Not recommended for new designs. Device is in production to support existing customers, but TI does not recommend using this part in a new design.

PREVIEW: Device has been announced but is not in production. Samples may or may not be available.

OBSOLETE: TI has discontinued the production of the device.

⁽²⁾ Eco Plan - The planned eco-friendly classification: Pb-Free (RoHS), Pb-Free (RoHS Exempt), or Green (RoHS & no Sb/Br) - please check <http://www.ti.com/productcontent> for the latest availability information and additional product content details.

TBD: The Pb-Free/Green conversion plan has not been defined.

Pb-Free (RoHS): TI's terms "Lead-Free" or "Pb-Free" mean semiconductor products that are compatible with the current RoHS requirements for all 6 substances, including the requirement that lead not exceed 0.1% by weight in homogeneous materials. Where designed to be soldered at high temperatures, TI Pb-Free products are suitable for use in specified lead-free processes.

Pb-Free (RoHS Exempt): This component has a RoHS exemption for either 1) lead-based flip-chip solder bumps used between the die and package, or 2) lead-based die adhesive used between the die and leadframe. The component is otherwise considered Pb-Free (RoHS compatible) as defined above.

Green (RoHS & no Sb/Br): TI defines "Green" to mean Pb-Free (RoHS compatible), and free of Bromine (Br) and Antimony (Sb) based flame retardants (Br or Sb do not exceed 0.1% by weight in homogeneous material)

⁽³⁾ MSL, Peak Temp. -- The Moisture Sensitivity Level rating according to the JEDEC industry standard classifications, and peak solder temperature.

Important Information and Disclaimer:The information provided on this page represents TI's knowledge and belief as of the date that it is provided. TI bases its knowledge and belief on information provided by third parties, and makes no representation or warranty as to the accuracy of such information. Efforts are underway to better integrate information from third parties. TI has taken and continues to take reasonable steps to provide representative and accurate information but may not have conducted destructive testing or chemical analysis on incoming materials and chemicals. TI and TI suppliers consider certain information to be proprietary, and thus CAS numbers and other limited information may not be available for release.

In no event shall TI's liability arising out of such information exceed the total purchase price of the TI part(s) at issue in this document sold by TI to Customer on an annual basis.

EFC (R-PSIP-G3) PLASTIC SINGLE-IN-LINE MODULE

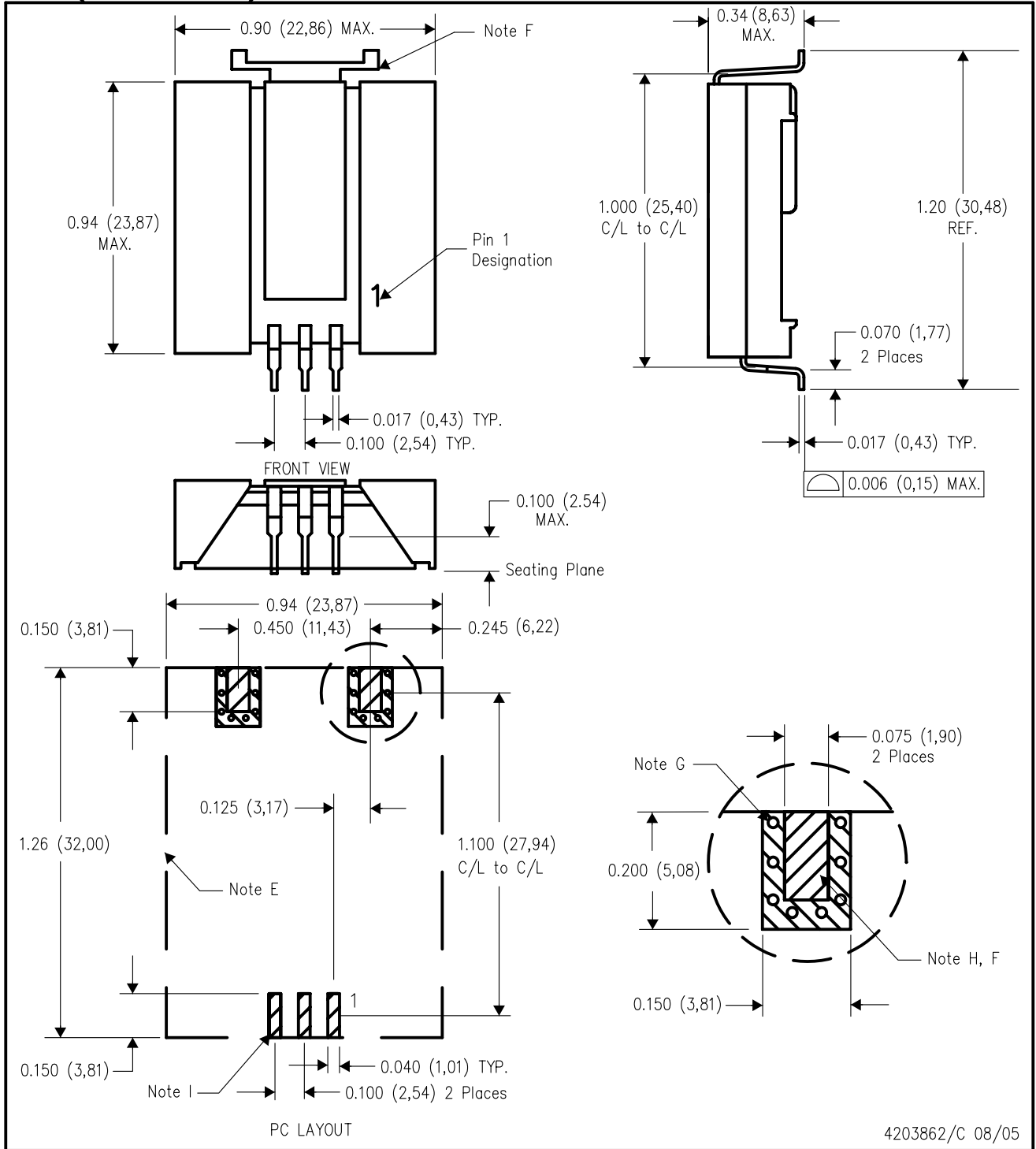

4203862/C 08/05

- NOTES:
- A. All linear dimensions are in inches (mm).
 - B. This drawing is subject to change without notice.
 - C. 2 place decimals are ± 0.030 ($\pm 0,76$ mm).
 - D. 3 place decimals are ± 0.010 ($\pm 0,25$ mm).
 - E. Recommended mechanical keep out area.
 - F. The 2 pin tab is electrically isolated and can be grounded.
 - G. Vias are recommended to improve copper adhesion.
 - H. Solder mask openings to copper island for solder joints to mechanical pins.
 - I. Power pin connections should utilize two or more vias per input, ground and output pin.

EFD (R-PSIP-T3)

PLASTIC SINGLE-IN-LINE MODULE

Suffix V

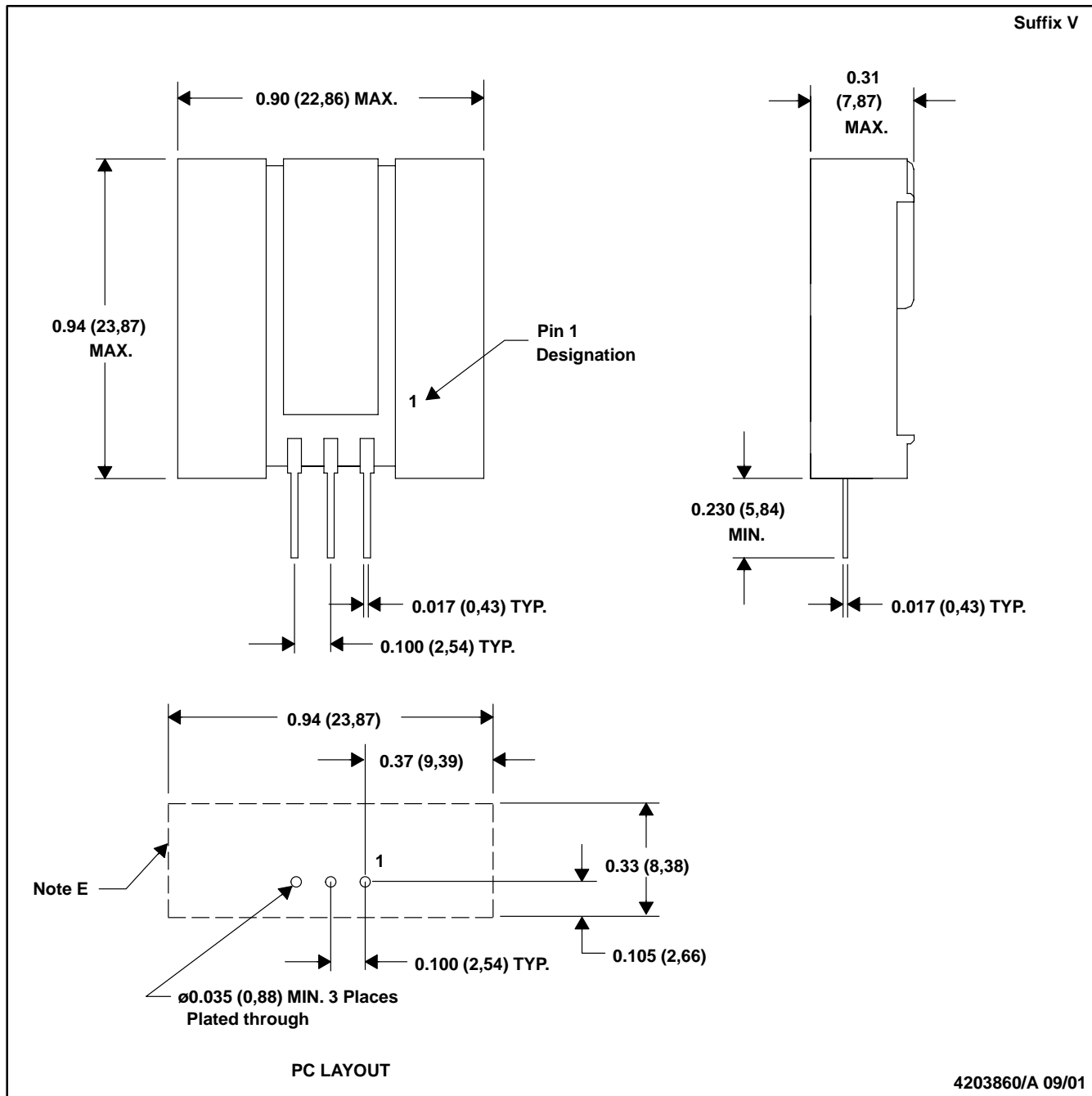

4203860/A 09/01

- NOTES: A. All linear dimensions are in inches (mm).
 B. This drawing is subject to change without notice.
 C. 2 place decimals are ± 0.030 ($\pm 0,76$ mm).
 D. 3 place decimals are ± 0.010 ($\pm 0,25$ mm).
 E. Recommended mechanical keep out area.

EFA (R-PSIP-T3)

PLASTIC SINGLE-IN-LINE MODULE

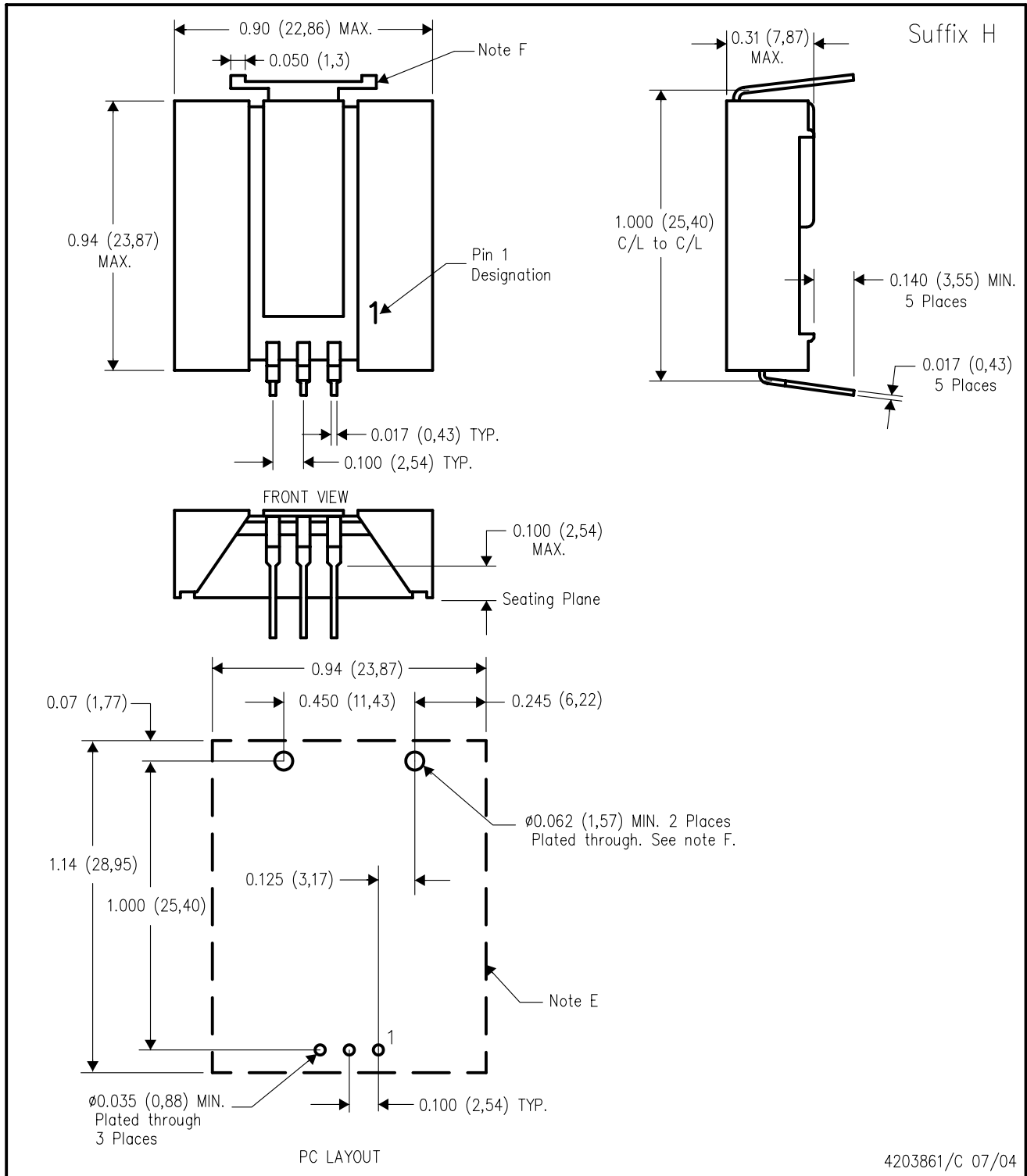

- NOTES:
- A. All linear dimensions are in inches (mm).
 - B. This drawing is subject to change without notice.
 - C. 2 place decimals are ± 0.030 ($\pm 0,76$ mm).
 - D. 3 place decimals are ± 0.010 ($\pm 0,25$ mm).
 - E. Recommended mechanical keep out area.
 - F. The 2 pin tab is electrically isolated and can be grounded.

IMPORTANT NOTICE

Texas Instruments Incorporated and its subsidiaries (TI) reserve the right to make corrections, modifications, enhancements, improvements, and other changes to its products and services at any time and to discontinue any product or service without notice. Customers should obtain the latest relevant information before placing orders and should verify that such information is current and complete. All products are sold subject to TI's terms and conditions of sale supplied at the time of order acknowledgment.

TI warrants performance of its hardware products to the specifications applicable at the time of sale in accordance with TI's standard warranty. Testing and other quality control techniques are used to the extent TI deems necessary to support this warranty. Except where mandated by government requirements, testing of all parameters of each product is not necessarily performed.

TI assumes no liability for applications assistance or customer product design. Customers are responsible for their products and applications using TI components. To minimize the risks associated with customer products and applications, customers should provide adequate design and operating safeguards.

TI does not warrant or represent that any license, either express or implied, is granted under any TI patent right, copyright, mask work right, or other TI intellectual property right relating to any combination, machine, or process in which TI products or services are used. Information published by TI regarding third-party products or services does not constitute a license from TI to use such products or services or a warranty or endorsement thereof. Use of such information may require a license from a third party under the patents or other intellectual property of the third party, or a license from TI under the patents or other intellectual property of TI.

Reproduction of TI information in TI data books or data sheets is permissible only if reproduction is without alteration and is accompanied by all associated warranties, conditions, limitations, and notices. Reproduction of this information with alteration is an unfair and deceptive business practice. TI is not responsible or liable for such altered documentation. Information of third parties may be subject to additional restrictions.

Resale of TI products or services with statements different from or beyond the parameters stated by TI for that product or service voids all express and any implied warranties for the associated TI product or service and is an unfair and deceptive business practice. TI is not responsible or liable for any such statements.

TI products are not authorized for use in safety-critical applications (such as life support) where a failure of the TI product would reasonably be expected to cause severe personal injury or death, unless officers of the parties have executed an agreement specifically governing such use. Buyers represent that they have all necessary expertise in the safety and regulatory ramifications of their applications, and acknowledge and agree that they are solely responsible for all legal, regulatory and safety-related requirements concerning their products and any use of TI products in such safety-critical applications, notwithstanding any applications-related information or support that may be provided by TI. Further, Buyers must fully indemnify TI and its representatives against any damages arising out of the use of TI products in such safety-critical applications.

TI products are neither designed nor intended for use in military/aerospace applications or environments unless the TI products are specifically designated by TI as military-grade or "enhanced plastic." Only products designated by TI as military-grade meet military specifications. Buyers acknowledge and agree that any such use of TI products which TI has not designated as military-grade is solely at the Buyer's risk, and that they are solely responsible for compliance with all legal and regulatory requirements in connection with such use.

TI products are neither designed nor intended for use in automotive applications or environments unless the specific TI products are designated by TI as compliant with ISO/TS 16949 requirements. Buyers acknowledge and agree that, if they use any non-designated products in automotive applications, TI will not be responsible for any failure to meet such requirements.

Following are URLs where you can obtain information on other Texas Instruments products and application solutions:

Products

Amplifiers	amplifier.ti.com
Data Converters	dataconverter.ti.com
DLP® Products	www.dlp.com
DSP	dsp.ti.com
Clocks and Timers	www.ti.com/clocks
Interface	interface.ti.com
Logic	logic.ti.com
Power Mgmt	power.ti.com
Microcontrollers	microcontroller.ti.com
RFID	www.ti-rfid.com
RF/IF and ZigBee® Solutions	www.ti.com/lprf

Applications

Audio	www.ti.com/audio
Automotive	www.ti.com/automotive
Broadband	www.ti.com/broadband
Digital Control	www.ti.com/digitalcontrol
Medical	www.ti.com/medical
Military	www.ti.com/military
Optical Networking	www.ti.com/opticalnetwork
Security	www.ti.com/security
Telephony	www.ti.com/telephony
Video & Imaging	www.ti.com/video
Wireless	www.ti.com/wireless

Mailing Address: Texas Instruments, Post Office Box 655303, Dallas, Texas 75265
Copyright © 2009, Texas Instruments Incorporated