

- High Efficiency > 85%
- Self-Contained Inductor
- Short Circuit Protection
- Over-Temperature Protection

The PT79SR100 is a line of Negative Input/Negative Output 3-terminal Integrated Switching

Regulators (ISRs). These ISRs have a maximum output current of -1.5 Amps and an output voltage that is laser trimmed to most industry standard voltages. They have excellent line and load regulation, and are ideal for applications, such as RS232 and Ethernet communications, ECL logic, and op-amp circuitry.

Standard Application

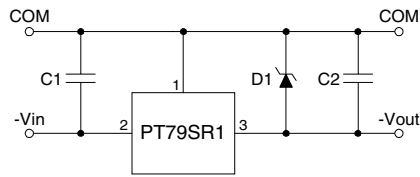

C1 = Optional ceramic (1 μ F)
C2 = Optional ceramic (1-5 μ F)
D1 = Zener diode required to clamp turn-on overshoot (See Application Note)

Pin-Out Information

Pin	Function
1	GND
2	-V _{in}
3	-V _{out}

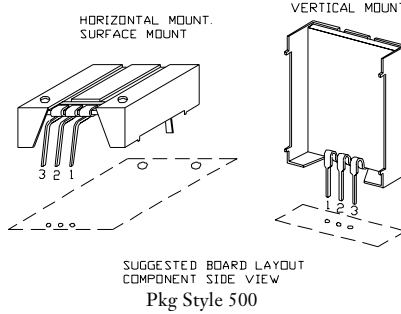

Ordering Information

PT79SR1	XX	Y
Output Voltage		Package Suffix
05 = -5.0 Volts		V = Vertical Mount
52 = -5.2 Volts		S = Surface Mount
06 = -6.0 Volts		H = Horizontal Mount
08 = -8.0 Volts		
09 = -9.0 Volts		
12 = -12.0 Volts		
15 = -15.0 Volts		

Specifications

Characteristics (T _a = 25°C unless noted)	Symbols	Conditions	PT79SR100 SERIES			
			Min	Typ	Max	Units
Output Current	I _o	Over V _{in} range	-0.1*	—	-1.5	A
Short Circuit Current	I _{sc}	V _{in} =V _o -4V	—	-3.5	—	Apk
Input Voltage Range	V _{in}	I _o =-0.1 to -1.5 A -0.1 \geq I _o \geq -1.5 A	-9 -19	—	-30 -30	V
Output Voltage Tolerance	Δ V _o	Over V _{in} range, I _o =-1.5 A T _a =20°C to shutdown	—	\pm 1.0	\pm 3.0	%V _o
Line Regulation	Reg _{line}	Over V _{in} range	—	\pm 1.0	\pm 2.0	%V _o
Load Regulation	Reg _{load}	-0.1 \leq I _o \leq -1.5 A	—	\pm 0.5	\pm 1.0	%V _o
V _o Ripple/Noise	V _n	V _{in} =-15V, I _o =-1.0 A, V _o =-5V	—	35	—	mV _{pp}
Transient Response	t _{tr}	50% load change V _o =overshoot/undershoot	—	100 30	—	μ Sec %V _o
Efficiency	η	V _{in} =-10V, I _o =-1.0A, V _o =-5V	—	85	—	%
Switching Frequency	f _o	Over V _{in} and I _o ranges	0.95	1.0	1.05	MHz
Absolute Maximum Operating Temperature Range	T _a		-40	—	+85	°C
Recommended Operating Temperature Range	T _a	Free Air Convection, (40-60LFM) Over V _{in} and I _o ranges	-40	—	+60**	°C
Thermal Resistance	θ _{ja}	Free Air Convection, (40-60LFM)	—	45	—	°C/W
Temperature Coefficient	T _c	Over V _{in} and I _o ranges	—	\pm 0.5	\pm 1.5	mV/°C
Storage Temperature	T _s		-40	—	+125	°C
Mechanical Shock	—	Per Mil-STD-883D, Method 2002.3	—	500	—	G's
Mechanical Vibration	—	Per Mil-STD-883D, Method 2007.2, 20-2000 Hz, soldered in a PC board	—	5	—	G's
Weight	—		—	7.0	—	Grams

* ISR will operate down to no load with reduced specifications.

** See Thermal Derating chart.

-1.5 Amp Negative Step-Down Integrated Switching Regulator

PT79SR105, -5.0 VDC (See Note 1)

Efficiency vs Output Current

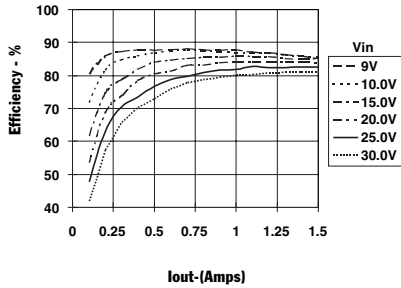

Ripple vs Output Current

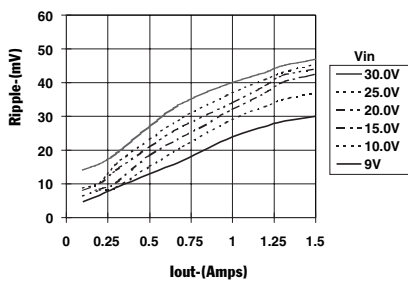

Thermal Derating (T_a) (See Note 2)

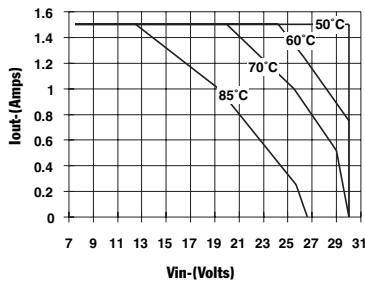

Power Dissipation vs Output Current

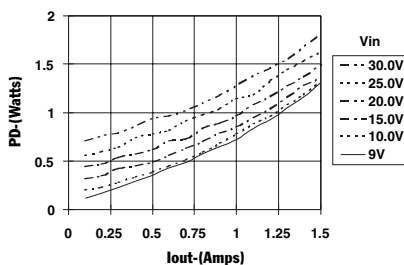

PT79SR112, -12.0 VDC (See Note 1)

Efficiency vs Output Current

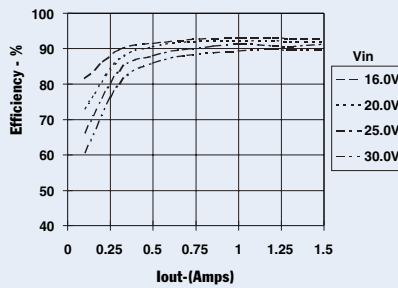

Ripple vs Output Current

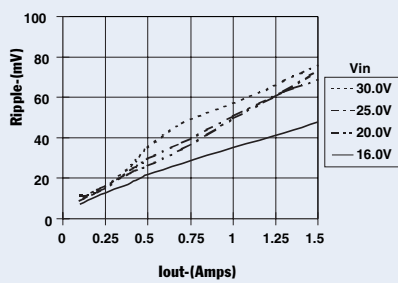

Thermal Derating (T_a) (See Note 2)

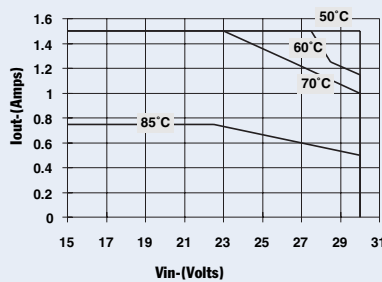

Power Dissipation vs Output Current

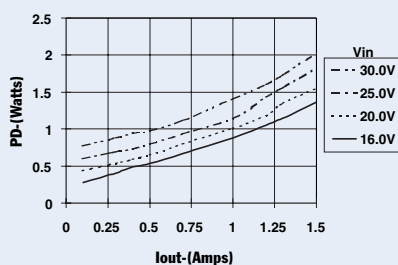

PT79SR115, -15.0 VDC (See Note 1)

Efficiency vs Output Current

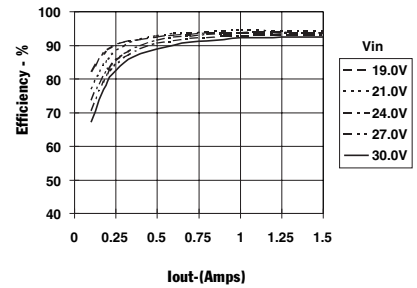

Ripple vs Output Current

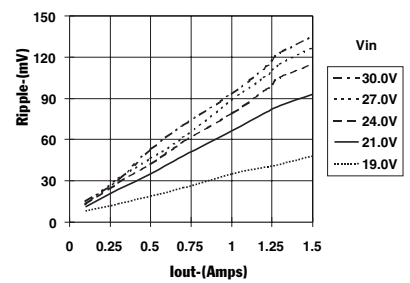

Thermal Derating (T_a) (See Note 2)

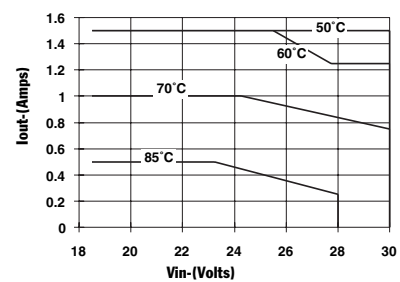

Power Dissipation vs Output Current

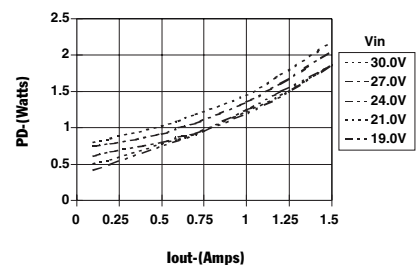

Note 1: All data listed in the above graphs, except for derating data, has been developed from actual products tested at 25°C. This data is considered typical data for the ISR.
 Note 2: Thermal derating graphs are developed in free air convection cooling of 40-60 LFM soldered in a printed circuit board. (See Thermal Application Notes.)

IMPORTANT NOTICE

Texas Instruments Incorporated and its subsidiaries (TI) reserve the right to make corrections, modifications, enhancements, improvements, and other changes to its products and services at any time and to discontinue any product or service without notice. Customers should obtain the latest relevant information before placing orders and should verify that such information is current and complete. All products are sold subject to TI's terms and conditions of sale supplied at the time of order acknowledgment.

TI warrants performance of its hardware products to the specifications applicable at the time of sale in accordance with TI's standard warranty. Testing and other quality control techniques are used to the extent TI deems necessary to support this warranty. Except where mandated by government requirements, testing of all parameters of each product is not necessarily performed.

TI assumes no liability for applications assistance or customer product design. Customers are responsible for their products and applications using TI components. To minimize the risks associated with customer products and applications, customers should provide adequate design and operating safeguards.

TI does not warrant or represent that any license, either express or implied, is granted under any TI patent right, copyright, mask work right, or other TI intellectual property right relating to any combination, machine, or process in which TI products or services are used. Information published by TI regarding third-party products or services does not constitute a license from TI to use such products or services or a warranty or endorsement thereof. Use of such information may require a license from a third party under the patents or other intellectual property of the third party, or a license from TI under the patents or other intellectual property of TI.

Reproduction of information in TI data books or data sheets is permissible only if reproduction is without alteration and is accompanied by all associated warranties, conditions, limitations, and notices. Reproduction of this information with alteration is an unfair and deceptive business practice. TI is not responsible or liable for such altered documentation.

Resale of TI products or services with statements different from or beyond the parameters stated by TI for that product or service voids all express and any implied warranties for the associated TI product or service and is an unfair and deceptive business practice. TI is not responsible or liable for any such statements.

Mailing Address:

Texas Instruments
Post Office Box 655303
Dallas, Texas 75265

This datasheet has been download from:

www.datasheetcatalog.com

Datasheets for electronics components.

Texas Instruments

<http://www.ti.com>

This file is the datasheet for the following electronic components:

PT79SR152 - <http://www.ti.com/product/pt79sr152?HQS=TI-null-null-dscatalog-df-pf-null-ww>