

Distributed by:

JAMECO[®]
ELECTRONICS

www.Jameco.com ♦ 1-800-831-4242

The content and copyrights of the attached
material are the property of its owner.

Jameco Part Number 907489



NOMINAL SIZE = 0.75 in x 0.5 in
(19,05 mm x 12,7 mm)

Features

- Up to 6-A Output Current
- 5-V Input Voltage
- Wide-Output Voltage Adjust (0.9 V to 3.6 V)
- Efficiencies up to 94 %
- 160 W/in³ Power Density
- On/Off Inhibit
- Under-Voltage Lockout
- Output Current Limit
- Pre-Bias Startup Capability
- Over-Temperature Protection
- Surface Mountable
- Operating Temp: -40 to +85 °C
- Safety Agency Approvals (Pending): UL 1950, CSA 22.2 950, EN60950 & VDE

Description

The PTH05000 series of non-isolated power modules are small in size and high on performance. Using double-sided surface mount construction and synchronous rectification technology, these regulators deliver up to 6 A of output current while occupying a PCB area of about half the size of a standard postage stamp. They are an ideal choice for applications where space, performance and cost are important design constraints.

The series operates from an input voltage of 5 V to provide step-down power conversion to any output voltage over the range, 0.9 V to 3.6 V. The output voltage of the PTH05000W is set within this range using a single resistor.

Operating features include an on/off inhibit, output voltage adjust (trim), an output current limit, and over-temperature protection.

For high efficiency these parts employ a synchronous rectifier output stage. An output pre-bias holdoff capability ensures that the output will not sink current during startup.

Target applications include telecom, industrial, and general purpose circuits, including low-power dual-voltage systems that use a DSP, microprocessor, or ASIC.

Package options include both through-hole and surface mount configurations.

Pin Configuration

Pin	Function
1	GND
2	V _{in}
3	Inhibit*
4	V _o Adjust
5	V _{out}

* Denotes negative logic:
Open = Output On
Ground = Output Off

Standard Application

R_{set} = Required to set the output voltage to a value higher than 0.9 V. See spec. table for values.
C_{in} = Required 330 μF capacitor
C_{out} = Optional 100 μF capacitor

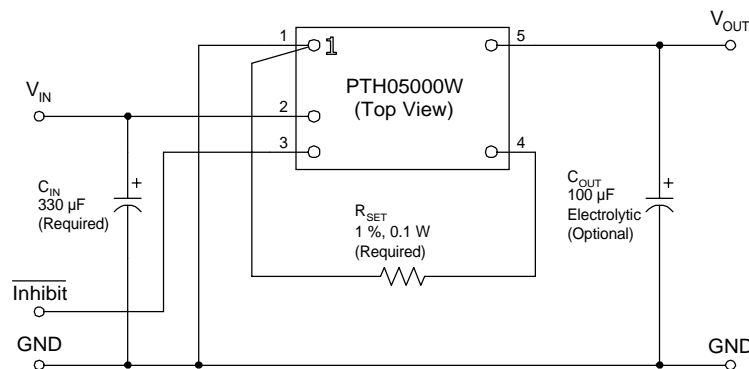

Ordering Information

Output Voltage (PTH05000□xx)		Package Options (PTH05000x□□) ⁽¹⁾		
Code	Voltage	Code	Description	Pkg Ref. ⁽²⁾
W	0.9 V – 3.6 V (Adjust)	AH	Horiz. T/H	(EUS)
		AS	SMD, Standard ⁽³⁾	(EUT)

- Notes:** (1) Add “T” to end of part number for tape and reel on SMD packages only.
 (2) Reference the applicable package reference drawing for the dimensions and PC board layout
 (3) “Standard” option specifies 63/37, Sn/Pb pin solder material.

Pin Descriptions

Vin: The positive input voltage power node to the module, which is referenced to common GND.

Vout: The regulated positive power output with respect to the GND node.

GND: This is the common ground connection for the ‘Vin’ and ‘Vout’ power connections. It is also the 0 VDC reference for the ‘Inhibit’ and ‘Vo Adjust’ control input.

Inhibit: The Inhibit pin is an open-collector/drain negative logic input that is referenced to GND. Applying a low-level ground signal to this input disables the module’s output and turns off the output voltage. When the Inhibit control is active, the input current drawn by the regulator is significantly reduced. If the Inhibit pin is left open-circuit, the module will produce an output whenever a valid input source is applied.

Vo Adjust: A 0.1 W 1 % resistor must be directly connected between this pin and the GND pin to set the output voltage to a value higher than 0.9 V. The temperature stability of the resistor should be 100 ppm/°C (or better). The set point range for the output voltage is from 0.9 V to 3.6 V. The resistor required for a given output voltage may be calculated from the following formula. If left open circuit, the output voltage will default to its lowest value. For further information on output voltage adjustment, consult the related application note.

$$R_{set} = 10 \text{ k}\Omega \cdot \frac{0.891 \text{ V}}{V_{out} - 0.9 \text{ V}} - 3.24 \text{ k}\Omega$$

The specification table gives the preferred resistor values for a number of standard output voltages.

Environmental & Absolute Maximum Ratings

Characteristics	Symbols	Conditions	Min	Typ	Max	Units
Operating Temperature Range	T _a	Over V _{in} Range	-40 (i)	—	+85	°C
Solder Reflow Temperature	T _{reflow}	Surface temperature of module body or pins	—	—	235 (ii)	°C
Storage Temperature	T _s	—	-40	—	+125	°C
Over Temperature Protection	OTP	IC junction temperature	—	150	—	°C
Mechanical Shock	—	Per Mil-STD-883D, Method 2002.3 1 msec, ½ sine, mounted	—	500	—	G's
Mechanical Vibration	—	Mil-STD-883D, Method 2007.2 20-2000 Hz	—	20	—	G's
Weight	—	—	—	2	—	grams
Flammability	—	Meets UL 94V-O	—	—	—	—

Notes: (i) For operation below 0 °C the external capacitors must have stable characteristics. Use either a low ESR tantalum, Os-con, or ceramic capacitor.
(ii) During reflow of SMD package version do not elevate peak temperature of the module, pins or internal components above the stated maximum.

Electrical Specifications Unless otherwise stated, T_a =25 °C, V_{in} =5 V, V_o =3.3 V, C_{in} =330 µF, C_{out} =0 µF, and I_o =I_o(max)

Characteristics	Symbols	Conditions	PTH05000W			Units
			Min	Typ	Max	
Output Current	I _o	0.9 V ≤ V _o ≤ 3.6 V, T _a =25 °C, natural convection T _a =60 °C, 200LFM	0 0	—	6 5.25 (1)	A
Input Voltage Range	V _{in}	Over I _o range	4.5	—	5.5	V
Set-Point Voltage Tolerance	V _o tol	—	—	—	±2 (2)	%V _o
Temperature Variation	ΔReg _{temp}	-40 °C < T _a < +85 °C	—	±0.5	—	%V _o
Line Regulation	ΔReg _{line}	Over V _{in} range	—	±5	—	mV
Load Regulation	ΔReg _{load}	Over I _o range	—	±5	—	mV
Total Output Variation	ΔReg _{tot}	Includes set-point, line, load, -40 °C ≤ T _a ≤ +85 °C	—	—	±3 (2)	%V _o
Efficiency	η	V _{in} =5 V, I _o =4 A RSET = 475 Ω V _o = 3.3 V RSET = 2.32 kΩ V _o = 2.5 V RSET = 4.87 kΩ V _o = 2.0 V RSET = 6.65 kΩ V _o = 1.8 V RSET = 11.5 kΩ V _o = 1.5 V RSET = 26.1 kΩ V _o = 1.2 V RSET = 84.5 kΩ V _o = 1.0 V	— — — — — — —	92 90 88 87 84 82 79	— — — — — — —	%
V _o Ripple (pk-pk)	V _r	20 MHz bandwidth V _o ≥ 3.3 V V _o ≤ 2.5 V	— —	30 25	— —	mVpp
Transient Response	t _{tr} ΔV _{tr}	1 A/µs load step, 50 to 100 % I _o max, V _o =1.8 V, C _{out} =100 µF Recovery time V _o over/undershoot	— —	70 100	— —	µSec mV
Current Limit	I _{lim}	ΔV _o = -50 mV	—	13	—	A
Under-Voltage Lockout	UVLO	V _{in} increasing V _{in} decreasing	— 3.4	3.8 3.5	4.3 —	V
Inhibit Control (pin 3) Input High Voltage Input Low Voltage Input Low Current	V _{IH} V _{IL} I _{IL}	Referenced to GND Pin 3 to GND	V _{in} -0.5 -0.2	— —	Open (3) 0.8	V
Standby Input Current	I _{in} standby	pins 1 & 3 connected	—	1	—	mA
Switching Frequency	f _s	Over V _{in} and I _o ranges	—	700	—	kHz
External Input Capacitance	C _{in}	—	330 (4)	—	—	µF
External Output Capacitance	C _{out}	Capacitance value Equiv. series resistance (non-ceramic)	0 0 4 (7)	100 (5) — —	1,000 (6) 300 —	µF mΩ
Reliability	MTBF	Per Bellcore TR-332 50 % stress, T _a =40 °C, ground benign	28	—	—	10 ⁶ Hrs

Notes: (1) See SOA curves or consult factory for appropriate derating.
(2) The set-point voltage tolerance is affected by the tolerance and stability of RSET. The stated limit is unconditionally met if RSET has a tolerance of 1 % with 100 ppm/°C or better temperature stability.
(3) The Inhibit control (pin 3) has an internal pull-up to V_{in}, and if left open-circuit the module will operate when input power is applied. A small low-leakage (<100 nA) MOSFET is recommended to control this input. See application notes for more information.
(4) The regulator requires a minimum of 330 µF input capacitor with a minimum 300 mA rms ripple current rating. For further information, consult the related application note on Capacitor Recommendations.
(5) An external output capacitor is not required for basic operation. Adding 100 µF of distributed capacitance at the load will improve the transient response.
(6) This is the calculated maximum. The minimum ESR limitation will often result in a lower value. Consult the application notes for further guidance.
(7) This is the typical ESR for all the electrolytic (non-ceramic) output capacitance. Use 7 mΩ as the minimum when using max-ESR values to calculate.

Characteristic Data; $V_{in} = 5\text{ V}$ (See Note A)

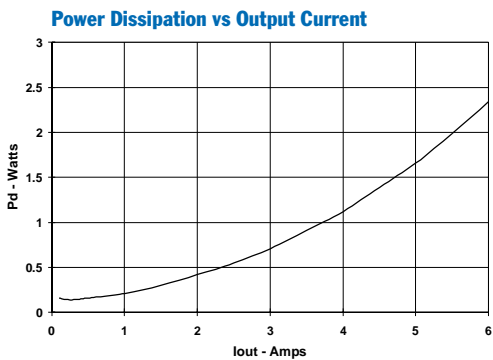
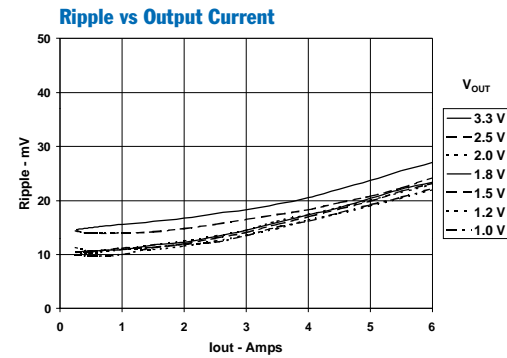
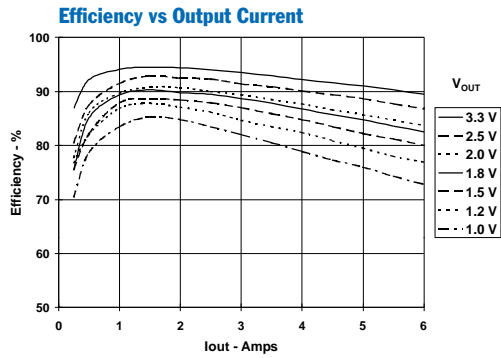

Safe Operating Area; $V_{in} = 5\text{ V}$ (See Note B)

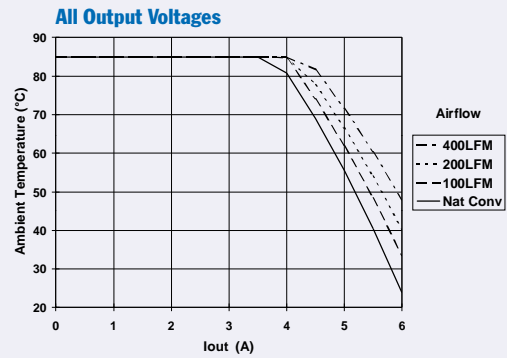

Note A: Characteristic data has been developed from actual products tested at 25 °C. This data is considered typical data for the Converter.

Note B: SOA curves represent the conditions at which internal components are at or below the manufacturer's maximum operating temperatures. Derating limits apply to modules soldered directly to a 4 in. × 4 in. double-sided PCB with 1 oz. copper.

Capacitor Recommendations for the PTH05000W Wide-Output Adjust Power Modules

Input Capacitor

The recommended input capacitor(s) is determined by the 330 μF minimum capacitance and 300 mArms minimum ripple current rating.

Ripple current, less than 300 m Ω equivalent series resistance (ESR), and temperature are the major considerations when selecting input capacitors. Unlike polymer tantalum, regular tantalum capacitors have a recommended minimum voltage rating of $2 \times$ (maximum DC voltage + AC ripple). This is standard practice to ensure reliability.

For improved ripple reduction on the input bus, ceramic capacitors [2] may be used to complement electrolytic types, and achieve the minimum required capacitance.

Output Capacitors (Optional)

For applications with load transients (sudden changes in load current), regulator response will benefit from an external output capacitance. The recommended output capacitance of 100 μF will allow the module to meet its transient response specification (see product data sheet). For most applications, a high quality computer-grade aluminum electrolytic capacitor is adequate. These capacitors provide decoupling over the frequency range, 2 kHz to 150 kHz, and are suitable for ambient temperatures above 0 $^{\circ}\text{C}$. For operation below 0 $^{\circ}\text{C}$ tantalum, ceramic or Os-Con type capacitors are recommended. When using one or more non-ceramic capacitors, the calculated equivalent ESR should be no lower than 4 m Ω (7 m Ω using the manufacturer's maximum ESR for a single capacitor). A list of preferred low-ESR type capacitors are identified in Table 1-1.

Ceramic Capacitors

Above 150 kHz the performance of aluminum electrolytic capacitors becomes less effective. To further improve the reflected input ripple current [2] or the output transient response, multilayer ceramic capacitors can also be added. Ceramic capacitors have very low ESR and their resonant frequency is higher than the bandwidth of the regulator. When used on the output their combined ESR is not critical as long as the total value of ceramic capacitance does not exceed 300 μF . Also, to prevent the formation of local resonances, do not place more than five identical ceramic capacitors in parallel with values of 10 μF or greater.

Tantalum Capacitors

Tantalum type capacitors can be used at both the input and output, and are recommended for applications where the ambient operating temperature can be less than 0 $^{\circ}\text{C}$. The AVX TPS, Sprague 593D/594/595 and Kemet T495/

T510 capacitor series are suggested over many other tantalum types due to their higher rated surge, power dissipation, and ripple current capability. As a caution many general purpose tantalum capacitors have considerably higher ESR, reduced power dissipation and lower ripple current capability. These capacitors are also less reliable as they have lower power dissipation and surge current ratings. Tantalum capacitors that do not have a stated ESR or surge current rating are not recommended for power applications.

When specifying Os-Con and polymer tantalum capacitors for the output, the minimum ESR limit will be encountered well before the maximum capacitance value is reached.

Capacitor Table

Table 1-1 identifies the characteristics of capacitors from a number of vendors with acceptable ESR and ripple current (rms) ratings. The recommended number of capacitors required at both the input and output buses is identified for each capacitor type.

This is not an extensive capacitor list. Capacitors from other vendors are available with comparable specifications. Those listed are for guidance. The RMS ripple current rating and ESR (at 100 kHz) are critical parameters necessary to insure both optimum regulator performance and long capacitor life.

Designing for Very Fast Load Transients

The transient response of the DC/DC converter has been characterized using a load transient with a di/dt of 1 A/ μs . The typical voltage deviation for this load transient is given in the data sheet specification table using the optional value of output capacitance. As the di/dt of a transient is increased, the response of a converter's regulation circuit ultimately depends on its output capacitor decoupling network. This is an inherent limitation with any DC/DC converter once the speed of the transient exceeds its bandwidth capability. If the target application specifies a higher di/dt or lower voltage deviation, the requirement can only be met with additional output capacitor decoupling. In these cases special attention must be paid to the type, value and ESR of the capacitors selected.

If the transient performance requirements exceed that specified in the data sheet, the selection of output capacitors becomes more important. For further guidance consult the separate application note, "Selecting Output Capacitors for PTH Products in High-Performance Applications."

PTH05000 Series

Table 1-1: Input/Output Capacitors

Capacitor Vendor, Type/ Series (Style)	Capacitor Characteristics					Quantity		Vendor Number
	Working Voltage	Value (µF)	Max. ESR at 100 kHz	Max. Ripple Current at 85 °C (Irms)	Physical Size (mm)	Input Bus	Output Bus	
Panasonic WA, Poly-Aluminum (SMD) FC, Aluminum (SMD) FK, Aluminum (SMD) FC, Aluminum (Radial)	10 V 16 V 16 V 10 V	330 µF 330 µF 330 µF 330 µF	0.035 Ω 0.150 Ω 0.160 Ω 0.117 Ω	2800mA 670mA 600 mA 550 mA	8×6.9 10×10.2 8×10.2 8×11.5	1 1 1 1	≤3 ≤3 ≤3 ≤3	EEFWA1A121P EEVFC1C331P EEVFK1C331P EEUFCA1A331
United Chemi-Con PXA, Poly-Alum (SMD) FS, Os-con (Radial) LXZ, Aluminum (Radial) MVZ, Aluminum (SMD) PSA, Poly-Aluminum (Radial)	10 V 10 V 16 V 25 V 6.3 V	330 µF 330 µF 330 µF 330 µF 390 µF	0.024 Ω 0.025 Ω 0.120 Ω 0.170 Ω 0.008 Ω	3770 mA 3500 mA 555 mA 450 mA 5080 mA	10×7.7 10×10.5 8×12 8×10 8×11.5	1 1 1 1 1	≤3 ≤3 ≤3 ≤3 ≤1	PXA10VC331MJ80TP 10FS330M LXZ16VB331M8x12LL MVZ25VC331MH10TP PSA6.3VB390MH11
NichiconAluminum WG (SMD) PM (Radial)	16 V 10 V	330 µF 330 µF	0.150 Ω 0.160 Ω	670 mA 460 mA	10×10 8×11.5	1 1	≤3 ≤3	UWG1C331MNR1GS UPM1A331MHH
Sanyo SVP, Os-con (SMD) SP, Os-con (Radial) TPE, Poscap Polymer (SMD)	10 V 10 V 6.3 V	330 µF 470 µF 330 µF	0.025 Ω 0.015 Ω 0.025 Ω	3700 mA 4500 mA 2400 mA	10×8 10×10.5 7.3L×4.3W	1 1 1	≤3 ≤2 ≤3	10SVP330MX 10SP470M 6TPE330ML
AVX Tantalum TPS (SMD)	10 V 10 V	330 µF 330 µF	0.100 Ω 0.060 Ω	1100 mA 2000 mA	7.3L ×4.3W ×4.1H	1 1	≤3 ≤3	TPSV337M010R0100 TPSV337M010R0060
Kemet (SMD) T520, Poly Aluminum T530, Organic Poly- Alum.	10 V 10 V	330 µF 330 µF	0.040 Ω 0.015 Ω	1200 mA 1100 mA	7.3L ×5.7W ×4.0H	1 1	≤3 ≤2	T520X337M010AS T530X337M010AS
Vishay-Sprague 594D, Tantalum (SMD) 595D, Tantalum (SMD) 94SVP, Os-con (SMD) 94SA, Os-con (Radial)	10 V 10 V 6.3 V 6.3 V	330 µF 330 µF 330 µF 330 µF	0.045 Ω 0.140 Ω 0.025 Ω 0.025 Ω	1400 mA 1000 mA 3300 mA 3500 mA	7.3L ×6.0W ×4.1H 10×8 10×10.5	1 1 1 1	≤3 ≤3 ≤3 ≤3	594D337X0010R2T 595D337X0010D2T 94SVP337X06R3F8 94SA337X06R3FBP
Kemet, Ceramic X5R (SMD)	16 V 6.3 V	10 47	0.002 Ω 0.002 Ω	—	1210 case 3225 mm	1 [2] 1 [2]	≤3 ≤2	C1210C106M4PAC C1210C476K9PAC
Murata, Ceramic X5R (SMD)	6.3 V 6.3 V 16 V 16 V	100 47 22 10	0.002 Ω	—	1210 case 3225 mm	3 [1] 1 [2] 1 [2] 1 [2]	≤1 ≤2 ≤3 ≤3	GRM32ER60J107M GRM32ER60J476M GRM32ER61C226K GRM32DR61C106K
TDK, Ceramic X5R (SMD)	6.3 V 6.3 V 16 V 16 V	100 47 22 10	0.002 Ω	—	1210 case 3225 mm	3 [1] 1 [2] 1 [2] 1 [2]	≤1 ≤2 ≤3 ≤3	C3225X5R0J107MT C3225X5R0J476MT C3225X5R1C226MT C3225X5R1C106MT

[1] A total capacitance of 300 µF is acceptable based on the surge current capability of ceramic capacitors.

[2] A ceramic capacitor may be used to complement electrolytic types at the input to further reduce high-frequency ripple current.

Adjusting the Output Voltage of the PTH05000W Wide-Output Adjust Power Modules

The $V_o Adjust$ control (pin 4) sets the output voltage of the PTH05000W product. The adjustment range is from 0.9 V to 3.6 V. The adjustment method requires the addition of a single external resistor, R_{set} , that must be connected directly between the $V_o Adjust$ and GND pins 1. Table 2-1 gives the preferred value of the external resistor for a number of standard voltages, along with the actual output voltage that this resistance value provides.

For other output voltages the value of the required resistor can either be calculated using the following formula, or simply selected from the range of values given in Table 2-2. Figure 2-1 shows the placement of the required resistor.

$$R_{set} = 10 \text{ k}\Omega \cdot \frac{0.891 \text{ V}}{V_{out} - 0.9 \text{ V}} - 3.24 \text{ k}\Omega$$

Table 2-1; Preferred Values of R_{set} for Standard Output Voltages

V_{out} (Standard)	R_{set} (Pref'd Value)	V_{out} (Actual)
3.3 V	475 Ω	3.298 V
2.5 V	2.32 k Ω	2.502 V
2 V	4.87 k Ω	1.999 V
1.8 V	6.65 k Ω	1.801 V
1.5 V	11.5 k Ω	1.504 V
1.2 V	26.1 k Ω	1.204 V
1 V	84.5 k Ω	1.001 V
0.9 V	Open	0.9 V

Figure 2-1; $V_o Adjust$ Resistor Placement

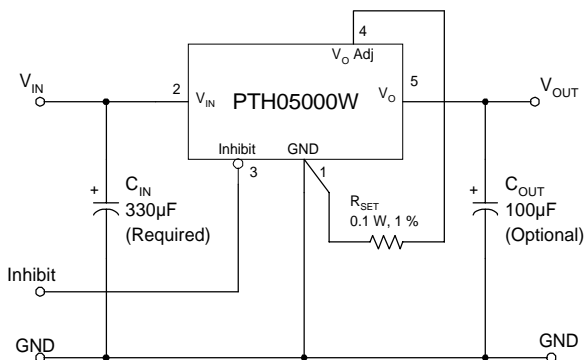

Table 2-2; Output Voltage Set-Point Resistor Values

V_a Req'd	R_{set}	V_a Req'd	R_{set}
0.900	Open	2.00	4.86 k Ω
0.925	353 k Ω	2.05	4.51 k Ω
0.950	175 k Ω	2.10	4.19 k Ω
0.975	116 k Ω	2.15	3.89 k Ω
1.000	85.9 k Ω	2.20	3.61 k Ω
1.025	68.0 k Ω	2.25	3.36 k Ω
1.050	56.2 k Ω	2.30	3.12 k Ω
1.075	47.7 k Ω	2.35	2.90 k Ω
1.100	41.3 k Ω	2.40	2.70 k Ω
1.125	36.4 k Ω	2.45	2.51 k Ω
1.150	32.4 k Ω	2.50	2.33 k Ω
1.175	29.2 k Ω	2.55	2.16 k Ω
1.200	26.5 k Ω	2.60	2.00 k Ω
1.225	24.2 k Ω	2.65	1.85 k Ω
1.250	22.2 k Ω	2.70	1.71 k Ω
1.275	20.5 k Ω	2.75	1.58 k Ω
1.300	19.0 k Ω	2.80	1.45 k Ω
1.325	17.7 k Ω	2.85	1.33 k Ω
1.350	16.6 k Ω	2.90	1.22 k Ω
1.375	15.5 k Ω	2.95	1.11 k Ω
1.400	14.6 k Ω	3.00	1.00 k Ω
1.425	13.7 k Ω	3.05	904 Ω
1.450	13.0 k Ω	3.10	810 Ω
1.475	12.3 k Ω	3.15	720 Ω
1.50	11.6 k Ω	3.20	634 Ω
1.55	10.5 k Ω	3.25	551 Ω
1.60	9.49 k Ω	3.30	473 Ω
1.65	8.64 k Ω	3.35	397 Ω
1.70	7.90 k Ω	3.40	324 Ω
1.75	7.24 k Ω	3.45	254 Ω
1.80	6.66 k Ω	3.50	187 Ω
1.85	6.14 k Ω	3.55	122 Ω
1.90	5.67 k Ω	3.60	60 Ω
1.95	5.25 k Ω		

Notes:

1. Use a 0.1 W resistor. The tolerance should be 1 %, with a temperature stability of 100 ppm/ $^{\circ}\text{C}$ (or better). Place the resistor as close to the regulator as possible. Connect the resistor directly between pins 4 and 1 using dedicated PCB traces.
2. Never connect capacitors from $V_o Adjust$ to either GND or V_{out} . Any capacitance added to the $V_o Adjust$ pin will affect the stability of the regulator.

Power-Up Characteristics

When configured per their standard application, the PTH03000 and PTH05000 series of power modules will produce a regulated output voltage following the application of a valid input source voltage. During power up, internal soft-start circuitry slows the rate that the output voltage rises, thereby limiting the amount of in-rush current that can be drawn from the input source. The soft-start circuitry introduces a short time delay (typically 10 ms) into the power-up characteristic. This is from the point that a valid input source is recognized. Figure 3-1 shows the power-up waveforms for a PTH05000W (5-V input), with the output voltage set point adjusted for a 2-V output. The waveforms were measured with a 5-A resistive load. The initial rise in input current when the input voltage first starts to rise is the charge current drawn by the input capacitors.

Figure 3-1

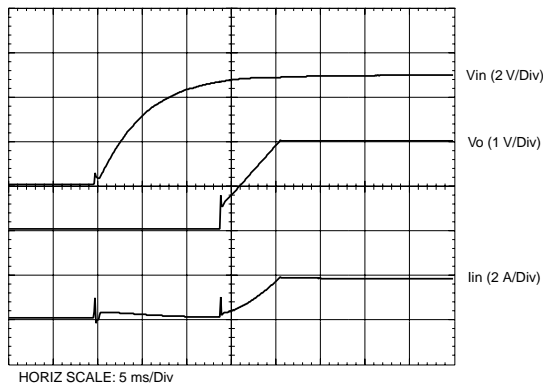

Current Limit Protection

The PTHxx000W modules protect against load faults with a continuous current limit characteristic. Under a load fault condition the output current cannot exceed the current limit value. Attempting to draw current that exceeds the current limit value causes the output voltage to be progressively reduced. Current is continuously supplied to the fault until it is removed. Upon removal of the fault, the output voltage will promptly recover.

Thermal Shutdown

Thermal shutdown protects the module's internal circuitry against excessively high temperatures. A rise in temperature may be the result of a drop in airflow, a high ambient temperature, or a sustained current limit condition. If the junction temperature of the internal components exceed 150 °C, the module will shutdown. This reduces the output voltage to zero. The module will start up automatically, by initiating a soft-start power up when the sensed temperature decreases 10 °C below the thermal shutdown trip point.

Output On/Off Inhibit

For applications requiring output voltage on/off control, the PTH03000W & PTH05000W power modules incorporate an output on/off *Inhibit* control (pin 3). The inhibit feature can be used wherever there is a requirement for the output voltage from the regulator to be turned off.

The power module functions normally when the *Inhibit* pin is left open-circuit, providing a regulated output whenever a valid source voltage is connected to V_{in} with respect to GND .

Figure 3-2 shows the typical application of the inhibit function. Note the discrete transistor (Q_1). The *Inhibit* control has its own internal pull-up to V_{in} potential. An open-collector or open-drain device is recommended to control this input.

Turning Q_1 on applies a low voltage to the *Inhibit* control pin and disables the output of the module. If Q_1 is then turned off, the module will execute a soft-start power-up sequence. A regulated output voltage is produced within 20 msec. Figure 3-3 shows the typical rise in the output voltage, following the turn-off of Q_1 . The turn off of Q_1 corresponds to the fall in the waveform, $Q_1 V_{gs}$. The waveforms were measured with a 5-A resistive load.

Figure 3-2

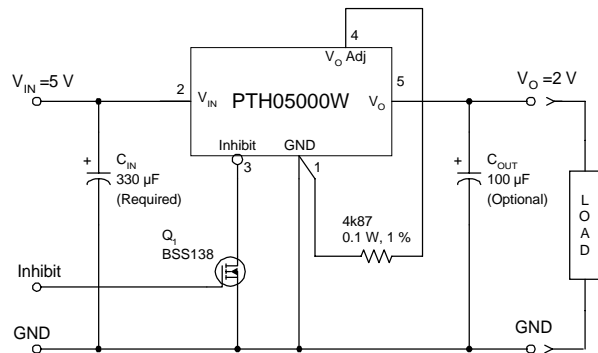
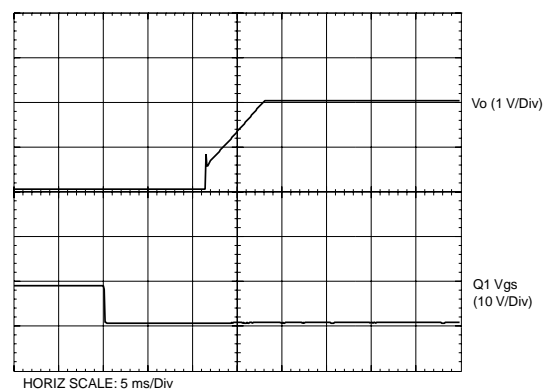

Figure 3-3



PTH05000W Startup with Output Pre-Bias

A pre-bias startup condition occurs as a result of an external voltage being present at the output of the power module prior to its output voltage rising. This often occurs in complex digital systems when current from another power source is backfed through a dual-supply logic component such as an FPGA or ASIC. Another path might be via clamp diodes (to a higher supply voltage) as part of a sequential power-up arrangement.

An output prebias can cause problems with power modules that incorporate synchronous rectifiers. This is because under most operating conditions, they can sink as well as source output current. Although the PTH05000W (5-V input) power module can sink current under normal operation, it will not do so during startup.¹ This is true as long as certain conditions are maintained.² Figure 3-1 shows an application schematic that demonstrates this capability. Figure 3-2 shows the waveforms of the circuit after input power is applied. Note that the module's output current (I_o) is never negative. Only positive current is sourced. This occurs when the output voltage is raised above that which is backfed from the 5-V input supply, via the diodes D_1 through D_4 .³

Notes

1. Start up includes both the application of a valid input source voltage, or the removal of a ground signal from the *Inhibit** control (pin 3) with a valid input source applied. The output of the regulator is effectively off (tri-state), during the period that the *Inhibit** control is held low.

2. To ensure that the regulator does not sink current, the input voltage must always be greater or equal to the output voltage throughout the power-up and power-down sequence.
3. If during power up, the backfeeding source is greater than the module's set-point voltage, the module's output voltage will remain higher than its set point. The output will remain out of regulation until the backfeeding source is either reduced in voltage or removed.

Figure 3-2; Start-up with Output Pre-Bias

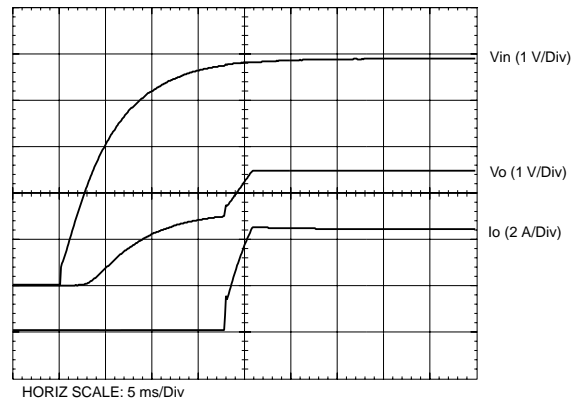
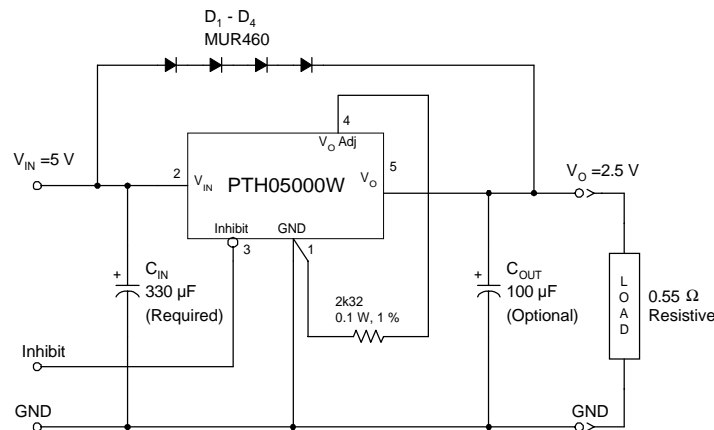

Figure 3-1; Schematic Demonstrating Startup with Output Pre-Bias



PACKAGING INFORMATION

Orderable Device	Status ⁽¹⁾	Package Type	Package Drawing	Pins	Package Qty	Eco Plan ⁽²⁾	Lead/Ball Finish	MSL Peak Temp ⁽³⁾
PTH05000WAD	ACTIVE	DIP MOD ULE	EUS	5	56	Pb-Free (RoHS)	Call TI	N / A for Pkg Type
PTH05000WAH	ACTIVE	DIP MOD ULE	EUS	5	56	Pb-Free (RoHS)	Call TI	N / A for Pkg Type
PTH05000WAS	ACTIVE	DIP MOD ULE	EUT	5	49	TBD	Call TI	Level-1-235C-UNLIM
PTH05000WAST	ACTIVE	DIP MOD ULE	EUT	5	250	TBD	Call TI	Level-1-235C-UNLIM
PTH05000WAZ	ACTIVE	DIP MOD ULE	EUT	5	49	Pb-Free (RoHS)	Call TI	Level-3-260C-168 HR
PTH05000WAZT	ACTIVE	DIP MOD ULE	EUT	5	250	Pb-Free (RoHS)	Call TI	Level-3-260C-168 HR

⁽¹⁾ The marketing status values are defined as follows:

ACTIVE: Product device recommended for new designs.

LIFEBUY: TI has announced that the device will be discontinued, and a lifetime-buy period is in effect.

NRND: Not recommended for new designs. Device is in production to support existing customers, but TI does not recommend using this part in a new design.

PREVIEW: Device has been announced but is not in production. Samples may or may not be available.

OBsolete: TI has discontinued the production of the device.

⁽²⁾ Eco Plan - The planned eco-friendly classification: Pb-Free (RoHS), Pb-Free (RoHS Exempt), or Green (RoHS & no Sb/Br) - please check <http://www.ti.com/productcontent> for the latest availability information and additional product content details.

TBD: The Pb-Free/Green conversion plan has not been defined.

Pb-Free (RoHS): TI's terms "Lead-Free" or "Pb-Free" mean semiconductor products that are compatible with the current RoHS requirements for all 6 substances, including the requirement that lead not exceed 0.1% by weight in homogeneous materials. Where designed to be soldered at high temperatures, TI Pb-Free products are suitable for use in specified lead-free processes.

Pb-Free (RoHS Exempt): This component has a RoHS exemption for either 1) lead-based flip-chip solder bumps used between the die and package, or 2) lead-based die adhesive used between the die and leadframe. The component is otherwise considered Pb-Free (RoHS compatible) as defined above.

Green (RoHS & no Sb/Br): TI defines "Green" to mean Pb-Free (RoHS compatible), and free of Bromine (Br) and Antimony (Sb) based flame retardants (Br or Sb do not exceed 0.1% by weight in homogeneous material)

⁽³⁾ MSL, Peak Temp. -- The Moisture Sensitivity Level rating according to the JEDEC industry standard classifications, and peak solder temperature.

Important Information and Disclaimer:The information provided on this page represents TI's knowledge and belief as of the date that it is provided. TI bases its knowledge and belief on information provided by third parties, and makes no representation or warranty as to the accuracy of such information. Efforts are underway to better integrate information from third parties. TI has taken and continues to take reasonable steps to provide representative and accurate information but may not have conducted destructive testing or chemical analysis on incoming materials and chemicals. TI and TI suppliers consider certain information to be proprietary, and thus CAS numbers and other limited information may not be available for release.

In no event shall TI's liability arising out of such information exceed the total purchase price of the TI part(s) at issue in this document sold by TI to Customer on an annual basis.

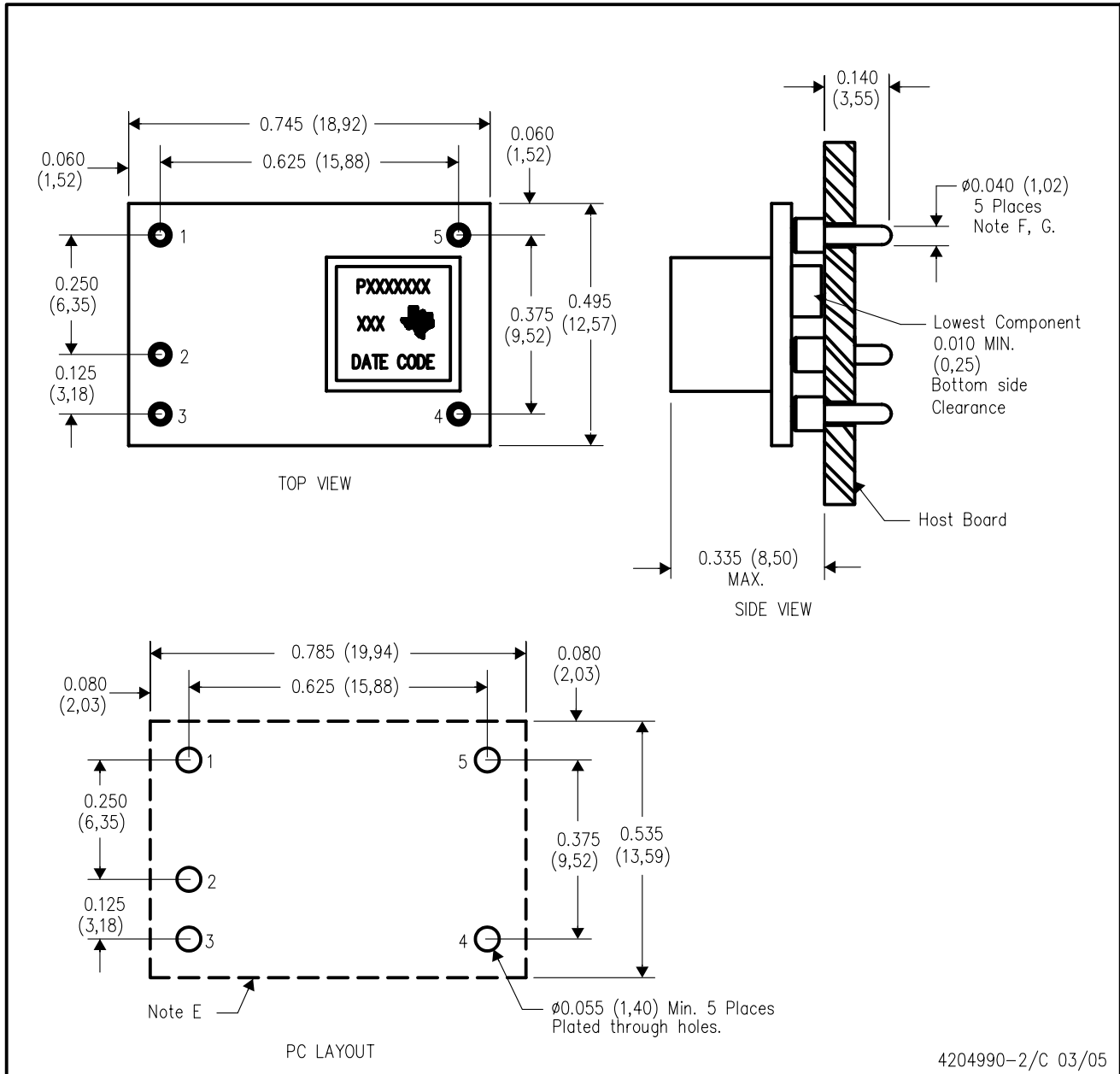

4204990-2/C 03/05

- NOTES:
- A. All linear dimensions are in inches (mm).
 - B. This drawing is subject to change without notice.
 - C. 2 place decimals are ± 0.030 ($\pm 0,76$ mm).
 - D. 3 place decimals are ± 0.010 ($\pm 0,25$ mm).
 - E. Recommended keep out area for user components.
 - F. Pins are 0.040" (1,02) diameter with 0.070" (1,78) diameter standoff shoulder.
 - G. All pins: Material - Copper Alloy
Finish - Tin (100%) over Nickel plate

EUT (R-PDSS-B5)

DOUBLE SIDED MODULE

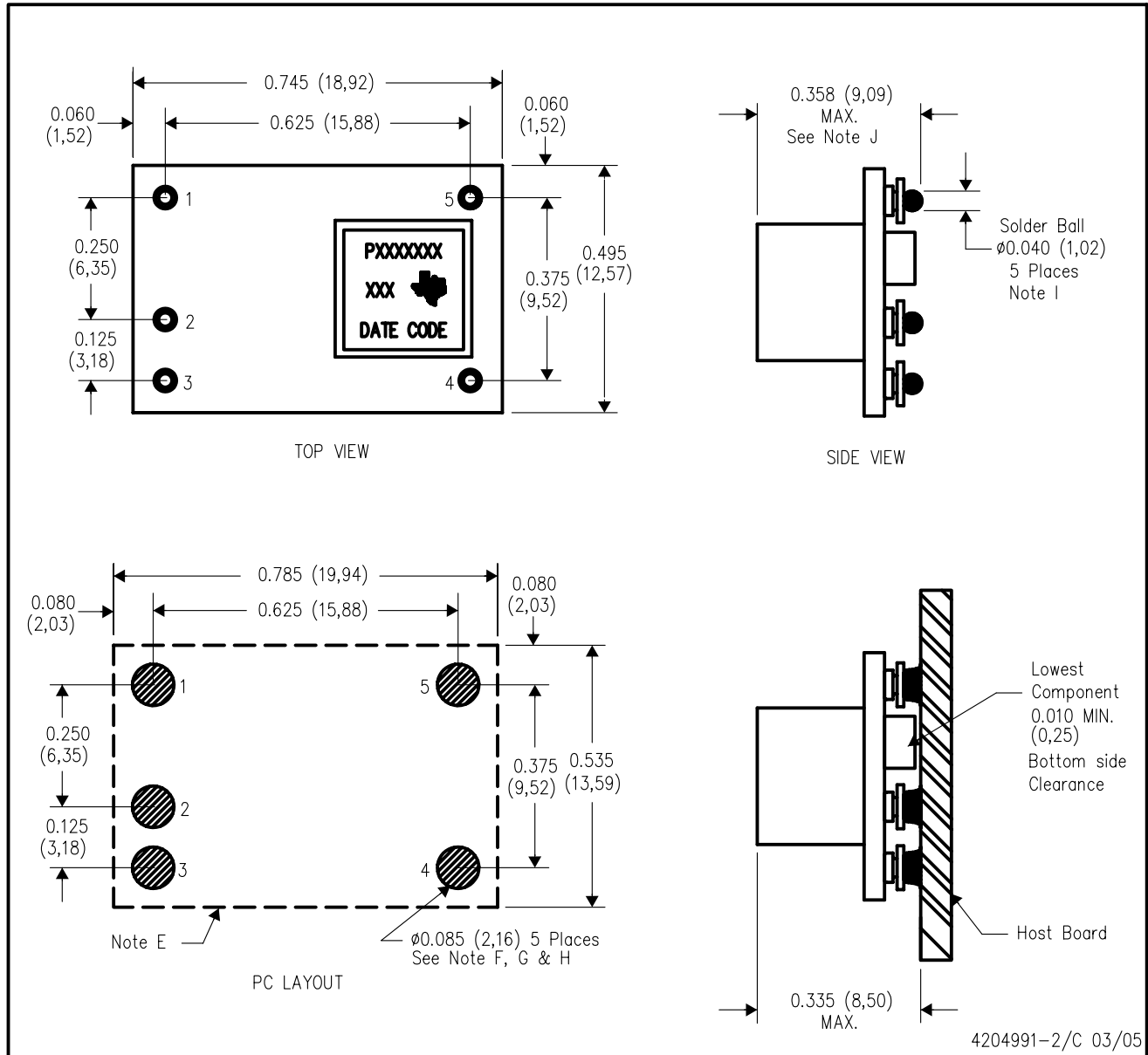

4204991-2/C 03/05

- NOTES:
- A. All linear dimensions are in inches (mm).
 - B. This drawing is subject to change without notice.
 - C. 2 place decimals are ± 0.030 ($\pm 0,76$ mm).
 - D. 3 place decimals are ± 0.010 ($\pm 0,25$ mm).
 - E. Recommended keep out area for user components.
 - F. Power pin connection should utilize two or more vias to the interior power plane of 0.025 (0,63) I.D. per input, ground and output pin (or the electrical equivalent).

- G. Paste screen opening: 0.080 (2,03) to 0.085 (2,16).
Paste screen thickness: 0.006 (0,15).
- H. Pad type: Solder mask defined.
- I. All pins: Material - Copper Alloy
Finish - Tin (100%) over Nickel plate
Solder Ball - See product data sheet.
- J. Dimension prior to reflow solder.

IMPORTANT NOTICE

Texas Instruments Incorporated and its subsidiaries (TI) reserve the right to make corrections, modifications, enhancements, improvements, and other changes to its products and services at any time and to discontinue any product or service without notice. Customers should obtain the latest relevant information before placing orders and should verify that such information is current and complete. All products are sold subject to TI's terms and conditions of sale supplied at the time of order acknowledgment.

TI warrants performance of its hardware products to the specifications applicable at the time of sale in accordance with TI's standard warranty. Testing and other quality control techniques are used to the extent TI deems necessary to support this warranty. Except where mandated by government requirements, testing of all parameters of each product is not necessarily performed.

TI assumes no liability for applications assistance or customer product design. Customers are responsible for their products and applications using TI components. To minimize the risks associated with customer products and applications, customers should provide adequate design and operating safeguards.

TI does not warrant or represent that any license, either express or implied, is granted under any TI patent right, copyright, mask work right, or other TI intellectual property right relating to any combination, machine, or process in which TI products or services are used. Information published by TI regarding third-party products or services does not constitute a license from TI to use such products or services or a warranty or endorsement thereof. Use of such information may require a license from a third party under the patents or other intellectual property of the third party, or a license from TI under the patents or other intellectual property of TI.

Reproduction of information in TI data books or data sheets is permissible only if reproduction is without alteration and is accompanied by all associated warranties, conditions, limitations, and notices. Reproduction of this information with alteration is an unfair and deceptive business practice. TI is not responsible or liable for such altered documentation.

Resale of TI products or services with statements different from or beyond the parameters stated by TI for that product or service voids all express and any implied warranties for the associated TI product or service and is an unfair and deceptive business practice. TI is not responsible or liable for any such statements.

Following are URLs where you can obtain information on other Texas Instruments products and application solutions:

Products		Applications	
Amplifiers	amplifier.ti.com	Audio	www.ti.com/audio
Data Converters	dataconverter.ti.com	Automotive	www.ti.com/automotive
DSP	dsp.ti.com	Broadband	www.ti.com/broadband
Interface	interface.ti.com	Digital Control	www.ti.com/digitalcontrol
Logic	logic.ti.com	Military	www.ti.com/military
Power Mgmt	power.ti.com	Optical Networking	www.ti.com/opticalnetwork
Microcontrollers	microcontroller.ti.com	Security	www.ti.com/security
Low Power Wireless	www.ti.com/lpw	Telephony	www.ti.com/telephony
		Video & Imaging	www.ti.com/video
		Wireless	www.ti.com/wireless

Mailing Address: Texas Instruments
Post Office Box 655303 Dallas, Texas 75265