

6-A NON-ISOLATED DDR/QDR MEMORY BUS TERMINATION MODULES



FEATURES

- V_{TT} Bus Termination Output (Output Tracks the System V_{REF})
- 6 A Output Current (8 A Peak)
- 3.3-V, 5-V or 12-V Input Voltage
- DDR and QDR Compatible
- On/Off Inhibit (for V_{TT} Standby)
- Undervoltage Lockout
- Operating Temperature: -40°C to 85°C
- Efficiencies up to 88%
- Output Overcurrent Protection (Non-Latching, Auto-Reset)

- 50 W/in³ Power Density
- Safety Agency Approvals: UL/cUL60950, EN60950, VDE
- Point-of-Load Alliance (POLA™) Compatible



NOMINAL SIZE = 0.87 in x 0.5 in
(22.1 mm x 12.57 mm)

DESCRIPTION

The PTHxx050Y are a series of ready-to-use switching regulator modules from Texas Instruments designed specifically for bus termination in DDR and QDR memory applications. Operating from either a 3.3-V, 5-V or 12-V input, the modules generate a V_{TT} output that will source or sink up to 6 A of current (8 A transient) to accurately track their V_{REF} input. V_{TT} is the required bus termination supply voltage, and V_{REF} is the reference voltage for the memory and chipset bus receiver comparators. V_{REF} is usually set to half the V_{DDQ} power supply voltage.

Both the PTHxx050Y series employs an actively switched synchronous rectifier output to provide state-of-the-art stepdown switching conversion. The products are small in size (0.87 in × 0.5 in), and are an ideal choice where space, performance, and high efficiency are desired, along with the convenience of a ready-to-use module.

Operating features include an on/off inhibit and output over-current protection (source mode only). The on/off inhibit feature allows the V_{TT} bus to be turned off to save power in a standby mode of operation.

Package options include both throughhole and surface mount configurations.

STANDARD APPLICATION

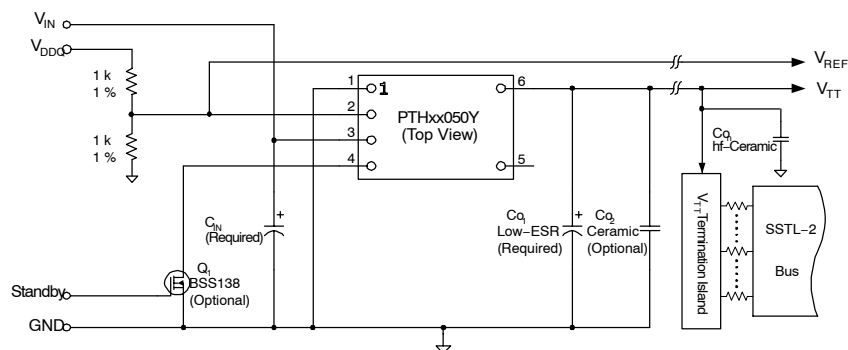

C_{IN} = Required Electrolytic Capacitor; 220 μF (3.3 \pm 5 V Input), 560 μF (12 V Input).
 C_{O1} = Required Low-ESR Electrolytic Capacitor; 470 μF (3.3 \pm 5 V Input), 940 μF (12 V Input).
 C_{O2} = Ceramic Capacitance for Response to a 3 A (+ 1.5 A) Load Transient; 200 μF (3.3 \pm 5 V Input), 400 μF (12 V Input).
 C_{ON} = Distributed hf-Ceramic Decoupling Capacitors for V_{TT} bus; as Recommended for DDR Memory Applications.



Please be aware that an important notice concerning availability, standard warranty, and use in critical applications of Texas Instruments semiconductor products and disclaimers thereto appears at the end of this data sheet.

POLA is a trademark of Texas Instruments.

ORDERING INFORMATION

PTHXX050Y (Base Part Number)				
Input Voltage	Part Number ⁽¹⁾	DESCRIPTION	Pb – free and RoHS	Mechanical Package ⁽²⁾
3.3 V	PTH03050YAH	Horizontal T/H	Yes ⁽³⁾	EUU
	PTH03050YAS	Standard SMD	No ⁽⁴⁾	EUV
	PTH03050YAZ	Optional SMD	Yes ⁽³⁾	EUV
5 V	PTH05050YAH	Horizontal T/H	Yes ⁽³⁾	EUU
	PTH05050YAS	Standard SMD	No ⁽⁴⁾	EUV
	PTH05050YAZ	Optional SMD	Yes ⁽³⁾	EUV
12 V	PTH12050YAH	Horizontal T/H	Yes ⁽³⁾	EUU
	PTH12050YAS	Standard SMD	No ⁽⁴⁾	EUV
	PTH12050YAZ	Optional SMD	Yes ⁽³⁾	EUV

- (1) Add *T* to end of part number for tape and reel on SMD packages only.
- (2) Reference the applicable package reference drawing for the dimensions and PC board layout.
- (3) *Lead (Pb) –free* option specifies Sn/Ag pin solder material.
- (4) *Standard* option specifies 63/37, Sn/Pb pin solder material.

ENVIRONMENTAL AND ABSOLUTE MAXIMUM RATINGS

voltages are with respect to GND

				UNIT
V _{REF}	Control input voltage			–0.3 V to V _I +0.3 V
T _A	Operating temperature range	Over V _{IN} range		–40°C to 85°C ⁽¹⁾
T _{wave}	Wave solder temperature	Surface temperature of module body or pins (5 seconds)	PTHXX050YAH	260°C ⁽²⁾
T _{reflow}	Solder reflow temperature	Surface temperature of module body or pins	PTHXX050YAS	235°C ⁽²⁾
			PTHXX050YAZ	260°C ⁽²⁾
T _s	Storage temperature			–40°C to 125°C
	Mechanical shock	Per Mil-STD-883D, Method 2002.3 1 msec, 1/2 Sine, mounted		500 G
	Mechanical vibration	Mil-STD-883D, Method 2007.2 20-2000 Hz		20 G
	Weight			2.9 grams
	Flammability	Meets UL 94V-O		

- (1) For operation below 0°C the external capacitors must have stable characteristics, use either a low ESR tantalum, Os-Con, or ceramic capacitor.
- (2) During soldering of package version, do not elevate peak temperature of the module, pins or internal components above the stated maximum.

ELECTRICAL SPECIFICATIONS

 $T_A = 25^\circ\text{C}$; nominal V_{IN} ; $V_{REF} = 1.25\text{ V}$; C_{IN} , C_{O1} , and C_{O2} = typical values; and $I_o = I_{o,max}$ (unless otherwise stated)

PARAMETER		TEST CONDITIONS		MIN	TYP	MAX	UNIT	
I_o	Output current	Over V_{REF} range	Continuous	0		$\pm 6^{(1)}$	A	
			Repetitive pulse			$\pm 8^{(2)}$	A	
V_{IN}	Input voltage range	Over I_o range	PTH03050Y	2.95		3.65	V	
			PTH05050Y	4.5		5.5		
			PTH12050Y	10.8		13.2		
ΔV_{REF}	Tracking range for V_{REF}			0.55		1.8	V	
$ V_{TT} - V_{REF} $	Tracking tolerance to V_{REF}	Over line, load and temperature		-10		10	mV	
η	Efficiency	$I_o = 4\text{ A}$	PTH03050Y		88%			
			PTH05050Y		87%			
			PTH12050Y		84%			
V_r	V_o Ripple (pk-pk)	20 MHz bandwidth			20		mVpp	
I_o trip	Overcurrent threshold	Reset, followed by auto recovery			12		A	
t_{tr}	Load transient response	15 A/ μs load step, from: - 1.5 A to 1.5 A ⁽³⁾	Recovery time		80		μsec	
			V_o over/undershoot		25	40	mV	
UVLO	Under-voltage lockout	V_{IN} Increasing	PTH03050Y	2.45		2.8	V	
			PTH05050Y	4.3		4.45		
			PTH12050Y	9.5		10.4		
		V_{IN} Dncreasing	PTH03050Y	2.0	2.40		V	
			PTH05050Y	3.4	3.7			
			PTH12050Y	8.8	9			
V_{IH}	Inhibit control (pin 4) Input high voltage	Referenced to GND		$V_{IN} - 0.5$		Open ⁽⁴⁾	V	
V_{IL}	Inhibit control (pin 4) Input low voltage			-0.2		0.6	V	
I_{IL} inhibit	Inhibit control (pin 4) Input low curent	Pin to GND			130		μA	
I_{IN} inh	Input standby current	Inhibit control (pin 4) to GND			10		mA	
f_s	Switching frequency	Over V_{IN} and I_o ranges	PTH03050Y/PTH05050Y	550	600	650	kHz	
			PTH12050Y	200	250	300		
C_{IN}	External input capacitance		PTH03050Y/PTH05050Y	220 ⁽⁵⁾			μF	
			PTH12050Y	560 ⁽⁵⁾				
C_{O1}, C_{O2}	External output capacitance	Capacitance value: Nonceramic	PTH03050Y/PTH05050Y	470 ⁽³⁾		3300 ⁽⁶⁾	μF	
			PTH12050Y	940 ⁽³⁾		3300 ⁽⁶⁾		
		Capacitance value: Ceramic	PTH03050Y/PTH05050Y		200 ⁽³⁾		300	μF
			PTH12050Y		400 ⁽³⁾		600	
		Equiv. series resistance (non-ceramic)		4 ⁽⁷⁾			m Ω	
MTBF	Reliability	Per Bellcore TR-332 50 % stress, $T_A = 40^\circ\text{C}$, ground benign		6			10^6 Hrs	

- (1) Rating is conditional on the module being directly soldered to a 4-layer PCB with 1 oz. copper. See the SOA curves or contact the factory for appropriate derating. The PTH03050Y and PTH05050Y require no derating up to 85°C operating temperature and natural convection airflow.
- (2) Up to 10 ms pulse period at 10% maximum duty.
- (3) The minimum value of external output capacitance value ensures that VTT meets the specified transient performance requirements for the memory bus terminations. Lower values of capacitance may be possible when the *measured* peak change in output current is consistently less than 3 A.
- (4) This control pin has an internal pull-up to the input voltage V_{IN} . If it is left open-circuit the module will operate when input power is applied. A small low-leakage (<100 nA) MOSFET is recommended for control. For further information, consult the related application note.
- (5) An input capacitor is required for proper operation. The capacitor must be rated for a minimum of 300 mA rms (750 mA rms for 12-V input) of ripple current.
- (6) This is the calculated maximum. The minimum ESR limitation will often result in a lower value. Consult the application notes for further guidance.
- (7) This is the typical ESR for all the electrolytic (non-ceramic) output capacitance. Use 8 m Ω as the minimum when using max-ESR values to calculate.

Terminal Functions

TERMINAL		DESCRIPTION
NAME	NO.	
V _{IN}	3	The positive input voltage power node to the module, which is referenced to common GND.
GND	1	This is the common ground connection for the V _{IN} and V _{TT} power connections. It is also the 0-VDC reference for the control inputs.
V _{REF}	2	The module senses the voltage at this input to regulate the output voltage, V _{TT} . The voltage at V _{REF} is also the reference voltage for the system bus receiver comparators. It is normally set to precisely half the bus driver supply voltage (V _{DDQ} + 2), using a resistor divider. The Thevenin impedance of the network driving the V _{REF} pin should not exceed 500 Ω. See the Typical DDR Application Diagram in the Application Information section for reference.
V _{TT}	6	This is the regulated power output from the module with respect to the GND node, and the tracking termination supply for the application data and address buses. It is precisely regulated to the voltage applied to the module's V _{REF} input, and is active active about 20 ms after a valid input source is applied to the module. Once active it will track the voltage applied at V _{REF} .
Inhibit	4	The Inhibit pin is an open-collector/drain negative logic input that is referenced to GND. Applying a low-level ground signal to this input turns off the output voltage, V _{TT} . Although the module is inhibited, a voltage, V _{DDQ} will be present at the output terminals, fed through the DDR memory. When the Inhibit is active, the input current drawn by the regulator is significantly reduced. If the Inhibit pin is left open circuit, the module will produce an output whenever a valid input source is applied. See the Typical DDR Application Diagram in the Application Information section for reference.
N/C	5	No Connection

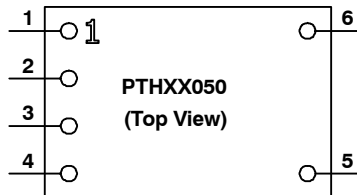

TYPICAL CHARACTERISTICS ($V_{REF} = 1.25\text{ V}$)⁽¹⁾⁽²⁾

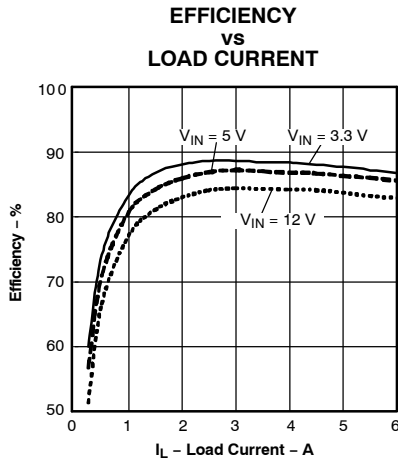

Figure 1.

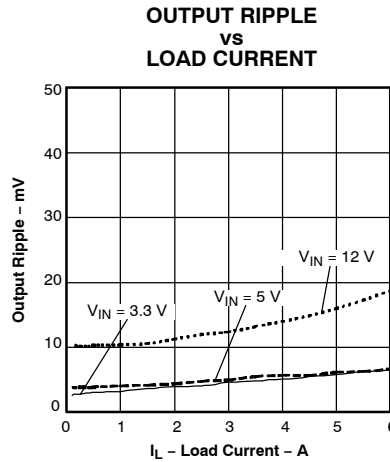

Figure 2.

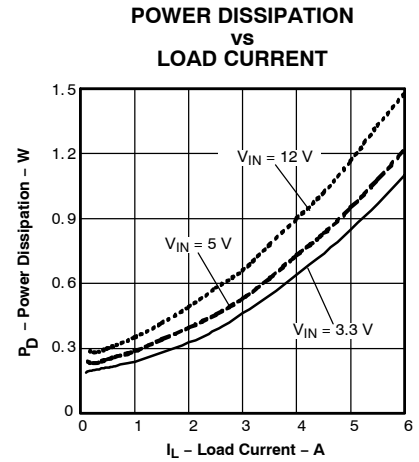

Figure 3.

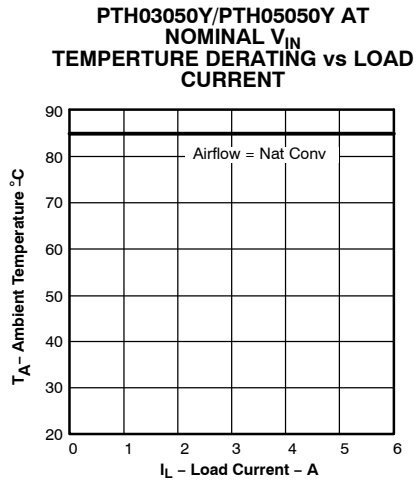

Figure 4.

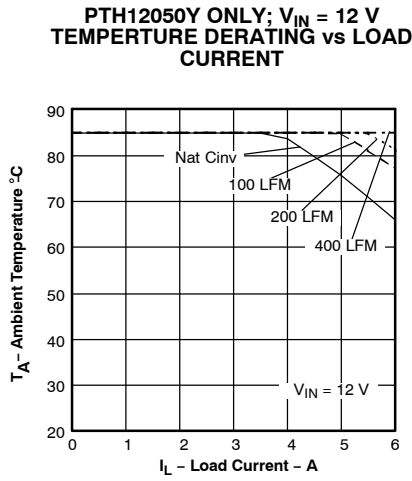

Figure 5.

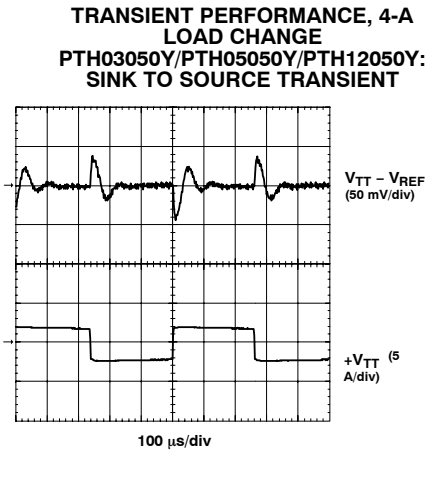
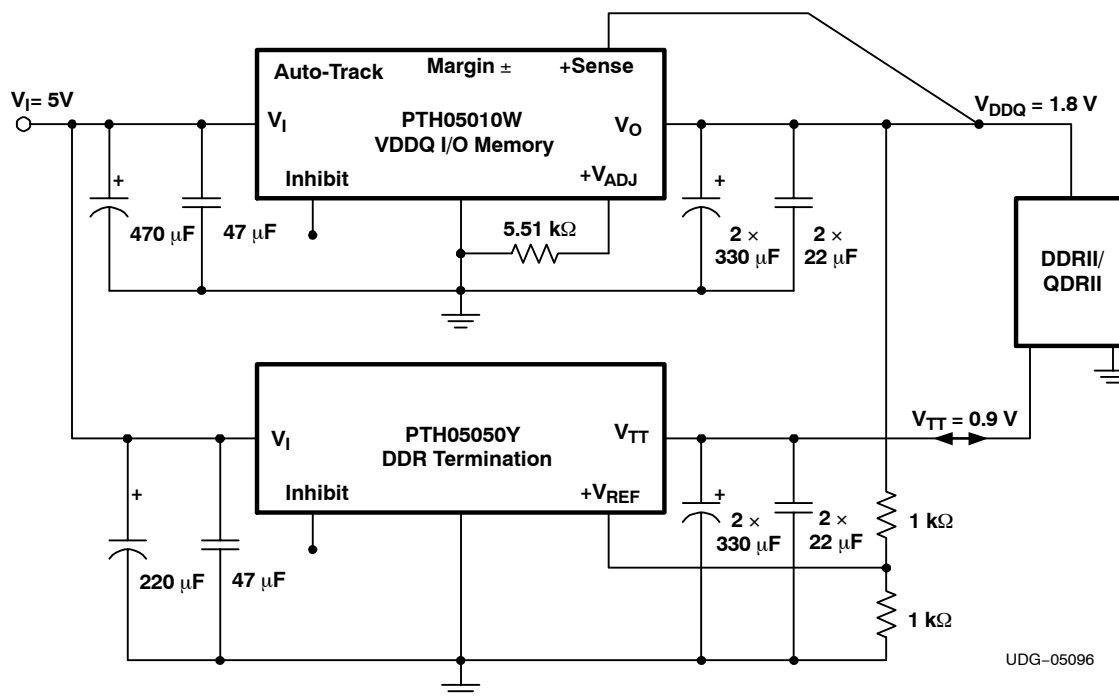

Figure 6.

- (1) The electrical characteristic data has been developed from actual products tested at 25°C. This data is considered typical for the converter. Applies to [Figure 1](#), [Figure 2](#), and [Figure 3](#).
- (2) The temperature derating curves represent the conditions at which internal components are at or below the manufacturer's maximum operating temperatures. Derating limits apply to modules soldered directly to a 4 mm x 4 mm double-sided PCB with 1 oz. copper. For surface mount packages (AS and AZ suffix), multiple vias (plated through holes) are required to add thermal paths around the power pins. Please refer to the mechanical specification for more information. Applies to [Figure 4](#), and [Figure 5](#).

APPLICATION INFORMATION

Typical DDR Application Diagram



UDG-05096

CAPACITOR RECOMMENDATIONS FOR THE PTH03050Y & PTH05050Y DDR POWER MODULES (3.3-V/5-V OPTION)

Input Capacitor

The recommended input capacitor(s) is determined by the 220 µF minimum capacitance and 500 mArms minimum ripple current rating.

Ripple current and less than 100 mΩ equivalent series resistance (ESR) values are the major considerations, along with temperature, when designing with different types of capacitors. Unlike polymer tantalum, regular tantalum capacitors have a recommended minimum voltage rating of 2 × (maximum DC voltage + AC ripple). This is standard practice to insure reliability.

For improved ripple reduction on the input bus, ceramic capacitors may be substituted for electrolytic types using the minimum required capacitance.

Output Capacitors

For applications with load transients (sudden changes in load current), regulator response will benefit from external output capacitance. The recommended output capacitance of 470 µF will allow the module to meet its transient response specification (see Electrical Specifications table). For most applications, a high quality computer-grade aluminum electrolytic capacitor is adequate. These capacitors provide decoupling over the frequency range, 2 kHz to 150 kHz, and are suitable when ambient temperatures are above 0°C. For operation below 0°C tantalum, ceramic or Os-Con type capacitors are recommended. When using one or more non-ceramic capacitors, the calculated equivalent ESR should be no lower than 4 mΩ (8 mΩ using the manufacturer's maximum ESR for a single capacitor). A list of preferred low-ESR type capacitors are identified in [Table 1](#).

APPLICATION INFORMATION (continued)

Ceramic Capacitors (Recommended)

Above 150 kHz the performance of aluminum electrolytic capacitors becomes less effective. To further improve the reflected input ripple current or the output transient response. Multilayer ceramic capacitors have very low ESR and their resonant frequency higher than the bandwidth of the regulator. They can be used to reduce the reflected ripple current at the input as well as improve the transient response of the output. When used on the output their combined ESR is not critical as long as the total value of ceramic capacitance does not exceed 300 μF . Also, to prevent the formation of local resonances, do not place more than five identical ceramic capacitors in parallel with values of 10 μF or greater.

Tantalum Capacitors

Tantalum type capacitors can be used at both the input and output, and are recommended for applications where the ambient operating temperature can be less than 0°C. The AVX TPS, Sprague 593D/594/595 and Kemet T495/T510 capacitor series are suggested over many other tantalum types due to their higher rated surge, power dissipation, and ripple current capability. As a caution many general purpose tantalum capacitors have considerably higher ESR, reduced power dissipation and lower ripple current capability. These capacitors are also less reliable when determining their power dissipation and surge current rating. Tantalum capacitors that do not have a stated ESR or surge current rating are not recommended for power applications.

When specifying Os-Con and polymer tantalum capacitors for the output, the minimum ESR limit will be encountered well before the maximum capacitance value is reached.

Capacitor Table

Table 1 identifies the characteristics of capacitors from a number of vendors with acceptable ESR and ripple current (rms) ratings. The recommended number of capacitors required at both the input and output buses is identified for each capacitor type.

This is not an extensive capacitor list. Capacitors from other vendors are available with comparable specifications. Those listed are for guidance. The RMS ripple current rating and ESR (at 100 kHz) are critical parameters necessary to insure both optimum regulator performance and long capacitor life.

Table 1. Input/Output Capacitors⁽¹⁾

Capacitor Vendor, Type/Series (Style)	Capacitor Characteristics					Quantity		Vendor Part Number
	Working Voltage (V)	Value (μF)	Max ESR at 100 kHz (Ω)	Max Ripple Current at 85°C (I _{rms}) (mA)	Physical Size (mm)	Input Bus	Output Bus	
Panasonic, Aluminum								
FC (Radial)	10	470	0.117	555	8×10	1	1	EEUFC1A471
FK (SMD)	25	470	0.080	850	10×10.2	1	1	EEVFK1E471P
FC (SMD)	16	470	0.150	670	10×10.2	1	1	EEVFC1C471P
United Chemi-Con								
PXA, Poly-Aluminum (SMD)	6.3	470	0.020	>4100	10×7.7	1	≤2	PXA6.3VC471MJ80TP
PS, Poly-Aluminum (Radial)	6.3	390	0.012	4770	8×11.5	1	≤1 ⁽²⁾	6PS390MH11
PSA, Poly-Aluminum (Radial)	10	470	0.008	5650	8×11.5	1	≤1	PSA10VB470MJ11
LXZ, Aluminum (Radial)	16	470	0.090	760	10×12.5	1	1	LXZ16VB471M10X12LL
Panasonic, Poly-Aluminum S/SE (SMD)	6.3	180	0.005	4000	7.3×4.3×4.2	2	N/R ⁽³⁾	EEFSE0J181R

(1) Capacitor Supplier Verification

Please verify availability of capacitors identified in this table. Capacitor suppliers may recommend alternative part numbers because of limited availability or obsolete products. In some instances, the capacitor product life cycle may be in decline and have short-term consideration for obsolescence.

RoHS, Lead-free and Material Details

Please consult capacitor suppliers regarding material composition, RoHS status, lead-free status, and manufacturing process requirements. Component designators or part number deviations can occur when material composition or soldering requirements are updated.

- (2) The total capacitance can be slightly lower than recommended minimum, but is acceptable based on the combined ripple current rating.
 (3) This capacitor is not recommended for the V_O bus. The capacitor ESR is below the specified minimum for non-ceramic capacitor.

APPLICATION INFORMATION (continued)

Table 1. Input/Output Capacitors (continued)

Capacitor Vendor, Type/Series (Style)	Capacitor Characteristics					Quantity		Vendor Part Number
	Working Voltage (V)	Value (μ F)	Max ESR at 100 kHz (Ω)	Max Ripple Current at 85°C (I _{rms}) (mA)	Physical Size (mm)	Input Bus	Output Bus	
Nichicon Aluminum								
WG (SMD)	10	470	0.150	670	10x10	1	1	UWG1A471MNR1GS
HD (Radial)	10	470	0.072	760	8x11.5	1	1	UHD1A471MPR
PM (Radial)	10	470	0.120	600	10x12.5	1	1	UPM1A471MPH6
Sanyo								
SP, Os-con (Radial)	10	470	0.015	4500	10x10.5	1	≤ 2	10SP470M
SVPA (SMD)	6.3	470	0.020	>4100	7,9x10	1	≤ 2	6SVPA470M
TPE, Poscap (SMD)	6.3	220	0.025	2400	7.3x4.3	1	≤ 3	6TPE220ML
AVX, Tantalum	10	330	0.045	1723	7.3L x5.7W x4.1H	1	≤ 5	TPSE337M010R0045
TPS (SMD)	10	330	0.060	1826		1	≤ 5	TPSV337M010R0060
Kemet, Poly-Tantalum								
T520 (SMD)	10	330	0.040	1800	4.3W x7.3L x4.0H	1	≤ 5	T520X337M010ASE045
T530 (SMD)	10	330	0.010	>5000		1	≤ 1	T530X337M010ASE010
Vishay-Sprague								
595D, Tantalum (SMD)	10	330	0.100	1040	7.2Lx6W x4.1H	1	≤ 5	595D377x0010D2T
594D, Tantalum (SMD)	10	330	0.045	2360	10x10.5	1	≤ 5	594D337X0016R2T
94SVP, Poly-Aluminum (Radial)	6.3	330	0.025	3500		1	≤ 3	94SA337X06R3FBP
Kemet, Ceramic X5R (SMD)	16	10	0.002	–	1210 /3225	1	≤ 5	C1210C106M4PAC
	6.3	47	0.002		3225 mm	1	≤ 5	C1210C476K9PAC
Murata, Ceramic X5R (SMD)	6.3	100	0.002	–	3225 mm	1 ⁽⁴⁾	≤ 3	GRM32ER60J107M
	6.3	47	0.002		3225 mm	1 ⁽⁴⁾	≤ 5	GRM32ER60J476M
	16	22	0.002			1 ⁽⁴⁾	≤ 5	GRM32ER61C226K
	16	10	0.002			1 ⁽⁴⁾	≤ 5	GRM32DR61C106K
TDK, Ceramic X5R (SMD)	6.3	100	0.002	–	3225 mm	1 ⁽⁴⁾	≤ 3	C3225X5R0J107MT
	6.3	47	0.002		3225 mm	1 ⁽⁴⁾	≤ 5	C3225X5R0J476MT
	16	22	0.002			1 ⁽⁴⁾	≤ 5	C3225X5R1C226MT
	16	10	0.002			1 ⁽⁴⁾	≤ 5	C3225X5R1C106MT

(4) A ceramic capacitor can be used to compliment electrolytic types at the input to further reduce high-frequency ripple current.

Designing for Very Fast Load Transients

The transient response of the DC/DC converter has been characterized using a load transient with a di/dt of 1 A/ μ s. The typical voltage deviation for this load transient is given in the data sheet specification table using the optional value of output capacitance. As the di/dt of a transient is increased, the response of a converter's regulation circuit ultimately depends on its output capacitor decoupling network. This is an inherent limitation with any DC/DC converter once the speed of the transient exceeds its bandwidth capability. If the target application specifies a higher di/dt or lower voltage deviation, the requirement can only be met with additional output capacitor decoupling. In these cases special attention must be paid to the type, value and ESR of the capacitors selected.

If the transient performance requirements exceed that specified in the data sheet, or the total amount of load capacitance is above 3300 μ F, the selection of output capacitors becomes more important.

CAPACITOR RECOMMENDATIONS FOR THE PTH12050Y DDR POWER MODULES PTH12050Y (12-V OPTION)

Input Capacitor

The recommended input capacitance is determined by the 560 μF minimum capacitance and 750 mArms minimum ripple current rating. A $\geq 10\text{-}\mu\text{F}$ X5R/X7R ceramic capacitor can be added to reduce the reflected input ripple current. The ceramic capacitor should be located between the input electrolytic and the module.

Ripple current, less than 100 m Ω equivalent series resistance (ESR) and temperature, are major considerations when selecting input capacitors. Unlike polymer-tantalum capacitors, regular tantalum capacitors have a recommended minimum voltage rating of $2 \times$ (max. dc voltage + ac ripple). No tantalum capacitors were found with sufficient voltage rating to meet this requirement. At temperatures below 0°C, the ESR of aluminum electrolytic capacitors increases. For these applications, Os-Con, polymer-tantalum, and polymer-aluminum types should be considered.

Output Capacitors

For applications with load transients (sudden changes in load current), regulator response will benefit from external output capacitance. The recommended minimum output capacitance of 940 μF will allow the module to meet its transient response specification (see Electrical Specifications table). For most applications, a high quality computer-grade aluminum electrolytic capacitor is adequate. These capacitors provide decoupling over the frequency range, 2 kHz to 150 kHz, and are suitable when ambient temperatures are above 0°C. For operation below 0°C tantalum, ceramic or Os-Con type capacitors are recommended. When using one or more non-ceramic capacitors, the calculated equivalent ESR should be no lower than 4 m Ω (8 m Ω using the manufacturer's maximum ESR for a single capacitor)

A list of preferred low-ESR type capacitors are identified in [Table 2](#).

In addition to electrolytic capacitance, adding a 10- μF to 22- μF X5R/X7R ceramic capacitor to the output reduces the output ripple voltage and improves the regulator's transient response. The measurement of both the output ripple and transient response is also best achieved across a 10- μF ceramic capacitor.

Ceramic Capacitors

Above 150 kHz, the performance of aluminum electrolytic capacitors is less effective. Multilayer ceramic capacitors have a low ESR and a resonant frequency higher than the bandwidth of the regulator. They can be used to reduce the reflected ripple current at the input, and improve the transient response of the output. When used on the output, their combined ESR is not critical as long as the total value of ceramic capacitance does not exceed 300 μF . Also, to prevent the formation of local resonances, do not place more than five identical ceramic capacitors in parallel with values of 10 μF or greater.

Tantalum Capacitors

Tantalum type capacitors are most suited for use on the output bus, and are recommended for applications where the ambient operating temperature can be less than 0°C. The AVX TPS, Sprague 593D/594/595, and Kemet T495/T510 capacitor series are suggested over other tantalum types due to their higher rated surge, power dissipation, and ripple current capability. As a caution, many general-purpose tantalum capacitors have considerably higher ESR, reduced power dissipation, and lower ripple current capability. These capacitors are also less reliable as they have lower power dissipation and surge current ratings. Tantalum capacitors that do not have a stated ESR or surge current rating are not recommended for power applications.

When specifying Os-con and polymer tantalum capacitors for the output, the minimum ESR limit is encountered well before the maximum capacitance value is reached.

Capacitor Table

[Table 2](#) identifies the characteristics of capacitors from a number of vendors with acceptable ESR and ripple current (rms) ratings. The recommended number of capacitors required at both the input and output buses is identified for each capacitor type.

Note: This is not an extensive capacitor list. Capacitors from other vendors are available with comparable specifications. Those listed are for guidance. The RMS ripple current rating and ESR (at 100 kHz) are critical parameters necessary to insure both optimum regulator performance and long capacitor life.

Table 2. Input/Output Capacitors⁽¹⁾

Capacitor Vendor, Type/Series (Style)	Capacitor Characteristics					Quantity		Vendor Number
	Working Voltage (V)	Value (μF)	Max ESR at 100 kHz (Ω)	Max Ripple Current at 85°C (I _{rms}) (mA)	Physical Size (mm)	Input Bus	Output Bus	
Panasonic, Aluminum FC Radial FK (SMD)	25	560	0.065	1205	12,5 × 15	1	1	EEUFC1E561S
	16	680	0.080	850	10 × 10,2	1	2	EEVFK1C681P
United Chemi-Con								
PXA, Poly-Aluminum (SMD)	16	330	0.014	5050	10 × 12,5	2	≤2	PXA16VC331MJ12TP
PS, Poly-Aluminum (Radial)	16	330	0.0014	5050	10 × 12,5	2	≤2	16PS330MJ12
LXZ, Aluminum (Radial)	16	680	0.068	1050	10 × 16	1	1	LXZ16VB681M10X16LL
Nichicon Aluminum	25	560	0.060	1060	12,5 × 15	1	1	UPM1E561MHH6
PM (Radial)	16	680	0.038	1430	10 × 16	1	2	UHD1C681MHR
HD (Radial)	35	560	0.048	1360	16 × 15	1	1	UPM1V561MHH6
Panasonic, Poly-Alum S/SE (SMD)	6.3	180	0.005	4000	7,3 × 4,3 × 4,2	N/R ⁽²⁾	≤1	EEFSE0J181R
Sanyo								
TPE, ps-Ccap (SMD)	10	330	0.025	3000	7,3 L × 5,7 W	N/R ⁽²⁾	≤3	10TPE330M
SEPC Os-con (Radial)	16	470	0.010	>6100	10 × 13	1 ⁽³⁾	≤1	16SEPC470M
SVP, Os-con (SMD)	16	330	0.016	4700	11 × 12	2	≤2	16SVP330M
SVPC Os-con (SMD)	4	1200	0.010	4700	8 × 11,9	N/R ⁽²⁾	≤1	4SVPC1200M
AVX, Tantalum TPS (SMD)	10	470	0.045	>1723	7,3 × 5,7 × 4,1	N/R ⁽²⁾	≤5	TPSE477M019R0045
	10	330	0.045	>1723		N/R ⁽²⁾	≤5	TPSE337M019R0045
Kemet								
T520, Poly-Tantalum (SMD)	6.3	470	0.040	1800		N/R ⁽²⁾	≤5	T520X477M006ASE040
T530, Tantalum/Organic	4	680	0.010	>5100	4,3 × 7,3 × 4	N/R ⁽²⁾	≤1	T530X687M004ASE010
T530, Tantalum/Organic	6.3	470	0.010	5200		N/R ⁽²⁾	≤1	T530X477M006ASE010
Vishay-Sprague								
594D, Tantalum (SMD)	10	470	0.100	1440	7,2 × 6 × 4,1	N/R ⁽²⁾	≤5	595D477X0010R2T
94SVP, Os-con (SMD)	16	330	0.017	>4500	10 × 12,7	2	≤2	94SVP337X0016F12
94SA, Organic (Radial)	16	1000	0.015	>9700	16 × 25	1	≤2	94SA108X0016HBP
Kemet, Ceramic X5R (SMD)	16	10	0.002		3225 mm	1 ⁽⁴⁾	≤5	C1210C106M4PAC
	6.3	47	0.002		3225 mm	N/R ⁽²⁾	≤5	C1210C476K9PAC
Murata, Ceramic X5R (SMD)	6.3	100	0.002		3225 mm	N/R ⁽²⁾	≤3	GRM32ER60J107M
	6.3	47			3225 mm	N/R ⁽²⁾	≤5	GRM32ER60J476M
	16	22				1 ⁽⁴⁾	≤5	GRM32ER61C226K
	16	10				1 ⁽⁴⁾	≤5	GRM32DR61C106K
TDK, Ceramic X5R (SMD)	6.3	100	0.002		3225 mm	N/R ⁽²⁾	≤3	C3225X5R0J107MT
	6.3	47			3225 mm	N/R ⁽²⁾	≤5	C3225X5R0J476MT
	16	22				1 ⁽⁴⁾	≤5	C3225X5R1C226MT
	16	10				1 ⁽⁴⁾	≤5	C3225X5R1C106MT

(1) Capacitor Supplier Verification

Please verify availability of capacitors identified in this table. Capacitor suppliers may recommend alternative part numbers because of limited availability or obsolete products. In some instances, the capacitor product life cycle may be in decline and have short-term consideration for obsolescence.

RoHS, Lead-free and Material Details

Please consult capacitor suppliers regarding material composition, RoHS status, lead-free status, and manufacturing process requirements. Component designators or part number deviations can occur when material composition or soldering requirements are updated.

(2) N/R – Not recommended. The capacitor voltage rating does not meet the minimum operating limits.

(3) A total capacitance of 470 μF is acceptable based on the combined ripple current rating.

(4) Ceramic capacitors are recommended to complement electrolytic types at the input and to reduce high-frequency ripple current.

Designing for Very Fast Load Transients

The transient response of the DC/DC converter has been characterized using a load transient with a di/dt of $1\text{ A}/\mu\text{s}$. The typical voltage deviation for this load transient is given in the data sheet specification table using the optional value of output capacitance. As the di/dt of a transient is increased, the response of a converter's regulation circuit ultimately depends on its output capacitor decoupling network. This is an inherent limitation with any DC/DC converter once the speed of the transient exceeds its bandwidth capability. If the target application specifies a higher di/dt or lower voltage deviation, the requirement can only be met with additional output capacitor decoupling. In these cases special attention must be paid to the type, value and ESR of the capacitors selected.

If the transient performance requirements exceed that specified in the data sheet, or the total amount of load capacitance is above $3300\ \mu\text{F}$, the selection of output capacitors becomes more important.

TAPE AND REEL SPECIFICATION

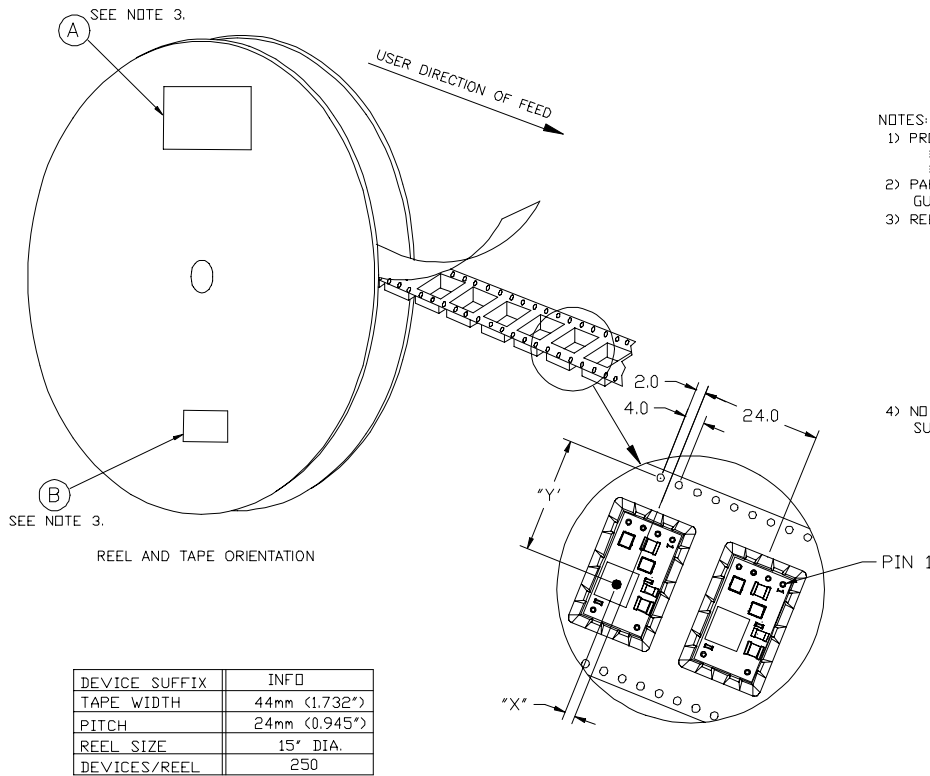

NOTES:

- 1) PROCESS IN ACCORDANCE WITH EIA-481-2
 - * TAPE LEADER DIMENSION 15.30" MIN.
 - * TAPE TRAILER DIMENSION 6.30" MIN.
- 2) PARTS SHOULD BE PACKAGED IN ACCORDANCE WITH ESD GUIDELINES IN EIA-541.
- 3) REEL LABEL: *A*-
 - * TI PART NUMBER.
 - * QUANTITY
 - * DATE CODE
 - * LOT NUMBER
 - * MSL DATA
 - * MADE IN
 - * ASSY SITE ORIGIN
 - * COUNTRY OF ORIGIN
 - * SUPPLIER
- *B*- ANTI-STATIC CAUTION LABEL
- 4) NO REQUIREMENT FOR TAPE DIRECTION OF FEED FROM SUPPLIER REEL.

PTXXXX5X	"X"	"Y"
PTH03050/05050	-2.2mm	23.2mm
PTH04050A	2.1mm	18.7mm
PTH04050C	-1.9mm	18.7mm
PTH12050	-1.4mm	22.7mm

TRAY SPECIFICATION

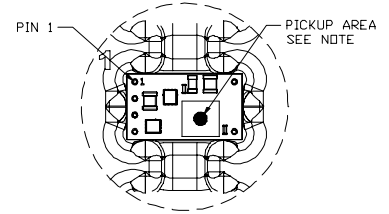
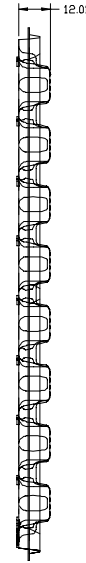
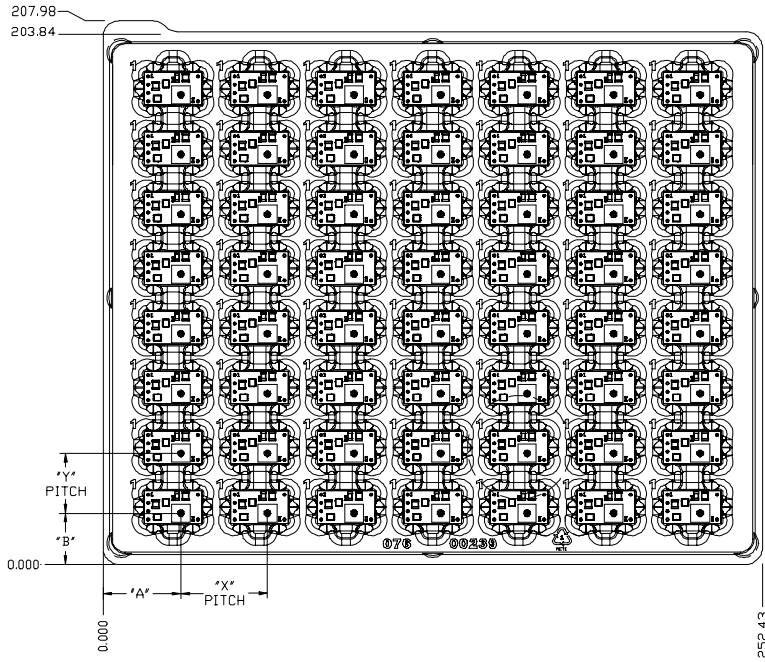

NOTE: THE INDUCTOR IS USED TO PICK AND PLACE THE MODULE. IT'S LOCATION MAY VARY FROM PACKAGE STYLE. SEE PRODUCT TABLE

PTXXX5X	"A"	"B"	"X"	"Y"
PTH03050/05050	29.90	19.62	33.12	22.86
PTH12050	29.35	20.39		
PTN04050A	25.29	23.88		
PTN04050C	25.32	19.88		

ALL DIMENSIONS ARE IN MILLIMETER.

DEVICES/TRAY	56
--------------	----

PACKAGING INFORMATION

Orderable Device	Status (1)	Package Type	Package Drawing	Pins	Package Qty	Eco Plan (2)	Lead/Ball Finish (6)	MSL Peak Temp (3)	Op Temp (°C)	Device Marking (4/5)	Samples
PTH03050YAH	ACTIVE	Through-Hole Module	EUU	6	56	RoHS (In Work) & Green (In Work)	SN	N / A for Pkg Type	-40 to 85		Samples
PTH03050YAS	ACTIVE	Surface Mount Module	EUV	6	56	RoHS (In Work) & Green (In Work)	SNPB	Level-1-235C-UNLIM/ Level-3-260C-168HRS	-40 to 85		Samples
PTH03050YAST	ACTIVE	Surface Mount Module	EUV	6	250	RoHS (In Work) & Green (In Work)	SNPB	Level-1-235C-UNLIM/ Level-3-260C-168HRS	-40 to 85		Samples
PTH03050YAZ	ACTIVE	Surface Mount Module	EUV	6	56	RoHS (In Work) & Green (In Work)	SNAGCU	Level-3-260C-168 HR	-40 to 85		Samples
PTH03050YAZT	ACTIVE	Surface Mount Module	EUV	6	250	RoHS (In Work) & Green (In Work)	SNAGCU	Level-3-260C-168 HR	-40 to 85		Samples
PTH05050YAH	ACTIVE	Through-Hole Module	EUU	6	56	RoHS (In Work) & Green (In Work)	SN	N / A for Pkg Type	-40 to 85		Samples
PTH05050YAS	ACTIVE	Surface Mount Module	EUV	6	56	RoHS (In Work) & Green (In Work)	SNPB	Level-1-235C-UNLIM/ Level-3-260C-168HRS	-40 to 85		Samples
PTH05050YAZ	ACTIVE	Surface Mount Module	EUV	6	56	RoHS (In Work) & Green (In Work)	SNAGCU	Level-3-260C-168 HR	-40 to 85		Samples
PTH05050YAZT	ACTIVE	Surface Mount Module	EUV	6	250	RoHS (In Work) & Green (In Work)	SNAGCU	Level-3-260C-168 HR	-40 to 85		Samples
PTH12050YAH	ACTIVE	Through-Hole Module	EUU	6	56	RoHS (In Work) & Green (In Work)	SN	N / A for Pkg Type	-40 to 85		Samples
PTH12050YAS	ACTIVE	Surface Mount Module	EUV	6	56	RoHS (In Work) & Green (In Work)	SNPB	Level-1-235C-UNLIM/ Level-3-260C-168HRS	-40 to 85		Samples
PTH12050YAST	ACTIVE	Surface Mount Module	EUV	6	250	RoHS (In Work) & Green (In Work)	SNPB	Level-1-235C-UNLIM/ Level-3-260C-168HRS	-40 to 85		Samples

Orderable Device	Status (1)	Package Type	Package Drawing	Pins	Package Qty	Eco Plan (2)	Lead/Ball Finish (6)	MSL Peak Temp (3)	Op Temp (°C)	Device Marking (4/5)	Samples
PTH12050YAZ	ACTIVE	Surface Mount Module	EUV	6	56	RoHS (In Work) & Green (In Work)	SNAGCU	Level-3-260C-168 HR	-40 to 85		Samples
PTH12050YAZT	ACTIVE	Surface Mount Module	EUV	6	250	RoHS (In Work) & Green (In Work)	SNAGCU	Level-3-260C-168 HR	-40 to 85		Samples

(1) The marketing status values are defined as follows:

ACTIVE: Product device recommended for new designs.

LIFEBUY: TI has announced that the device will be discontinued, and a lifetime-buy period is in effect.

NRND: Not recommended for new designs. Device is in production to support existing customers, but TI does not recommend using this part in a new design.

PREVIEW: Device has been announced but is not in production. Samples may or may not be available.

OBSOLETE: TI has discontinued the production of the device.

(2) **RoHS:** TI defines "RoHS" to mean semiconductor products that are compliant with the current EU RoHS requirements for all 10 RoHS substances, including the requirement that RoHS substance do not exceed 0.1% by weight in homogeneous materials. Where designed to be soldered at high temperatures, "RoHS" products are suitable for use in specified lead-free processes. TI may reference these types of products as "Pb-Free".

RoHS Exempt: TI defines "RoHS Exempt" to mean products that contain lead but are compliant with EU RoHS pursuant to a specific EU RoHS exemption.

Green: TI defines "Green" to mean the content of Chlorine (Cl) and Bromine (Br) based flame retardants meet JS709B low halogen requirements of <=100ppm threshold. Antimony trioxide based flame retardants must also meet the <=1000ppm threshold requirement.

(3) MSL, Peak Temp. - The Moisture Sensitivity Level rating according to the JEDEC industry standard classifications, and peak solder temperature.

(4) There may be additional marking, which relates to the logo, the lot trace code information, or the environmental category on the device.

(5) Multiple Device Markings will be inside parentheses. Only one Device Marking contained in parentheses and separated by a "~" will appear on a device. If a line is indented then it is a continuation of the previous line and the two combined represent the entire Device Marking for that device.

(6) Lead/Ball Finish - Orderable Devices may have multiple material finish options. Finish options are separated by a vertical ruled line. Lead/Ball Finish values may wrap to two lines if the finish value exceeds the maximum column width.

Important Information and Disclaimer:The information provided on this page represents TI's knowledge and belief as of the date that it is provided. TI bases its knowledge and belief on information provided by third parties, and makes no representation or warranty as to the accuracy of such information. Efforts are underway to better integrate information from third parties. TI has taken and continues to take reasonable steps to provide representative and accurate information but may not have conducted destructive testing or chemical analysis on incoming materials and chemicals. TI and TI suppliers consider certain information to be proprietary, and thus CAS numbers and other limited information may not be available for release.

In no event shall TI's liability arising out of such information exceed the total purchase price of the TI part(s) at issue in this document sold by TI to Customer on an annual basis.

EUU (R-PDSS-T6)

DOUBLE SIDED MODULE

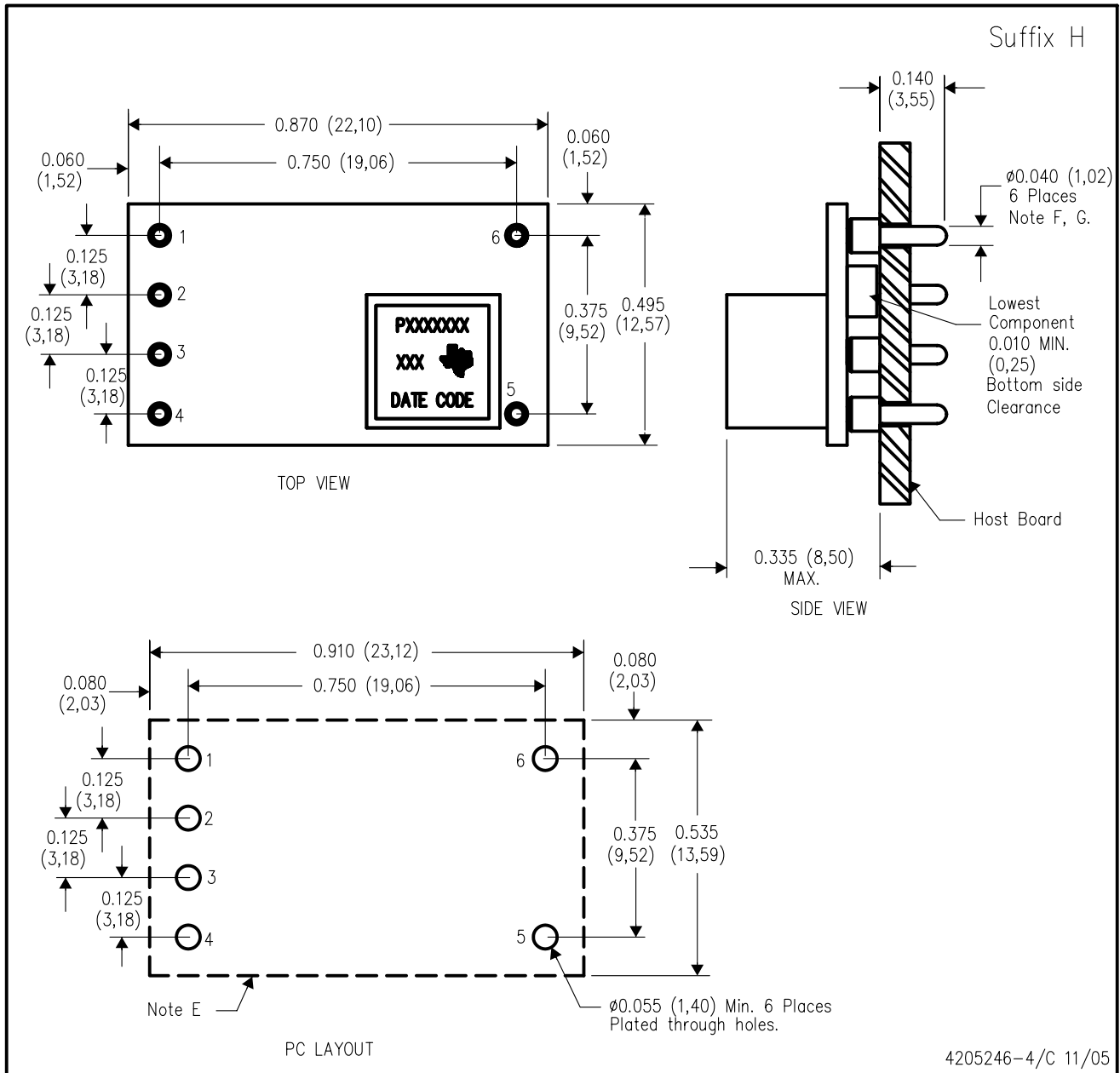

- NOTES:
- A. All linear dimensions are in inches (mm).
 - B. This drawing is subject to change without notice.
 - C. 2 place decimals are ± 0.030 ($\pm 0,76$ mm).
 - D. 3 place decimals are ± 0.010 ($\pm 0,25$ mm).
 - E. Recommended keep out area for user components.

- F. Pins are 0.040" (1,02) diameter with 0.070" (1,78) diameter standoff shoulder.
- G. All pins: Material - Copper Alloy
Finish - Tin (100%) over Nickel plate

EUV (R-PDSS-B6)

DOUBLE SIDED MODULE

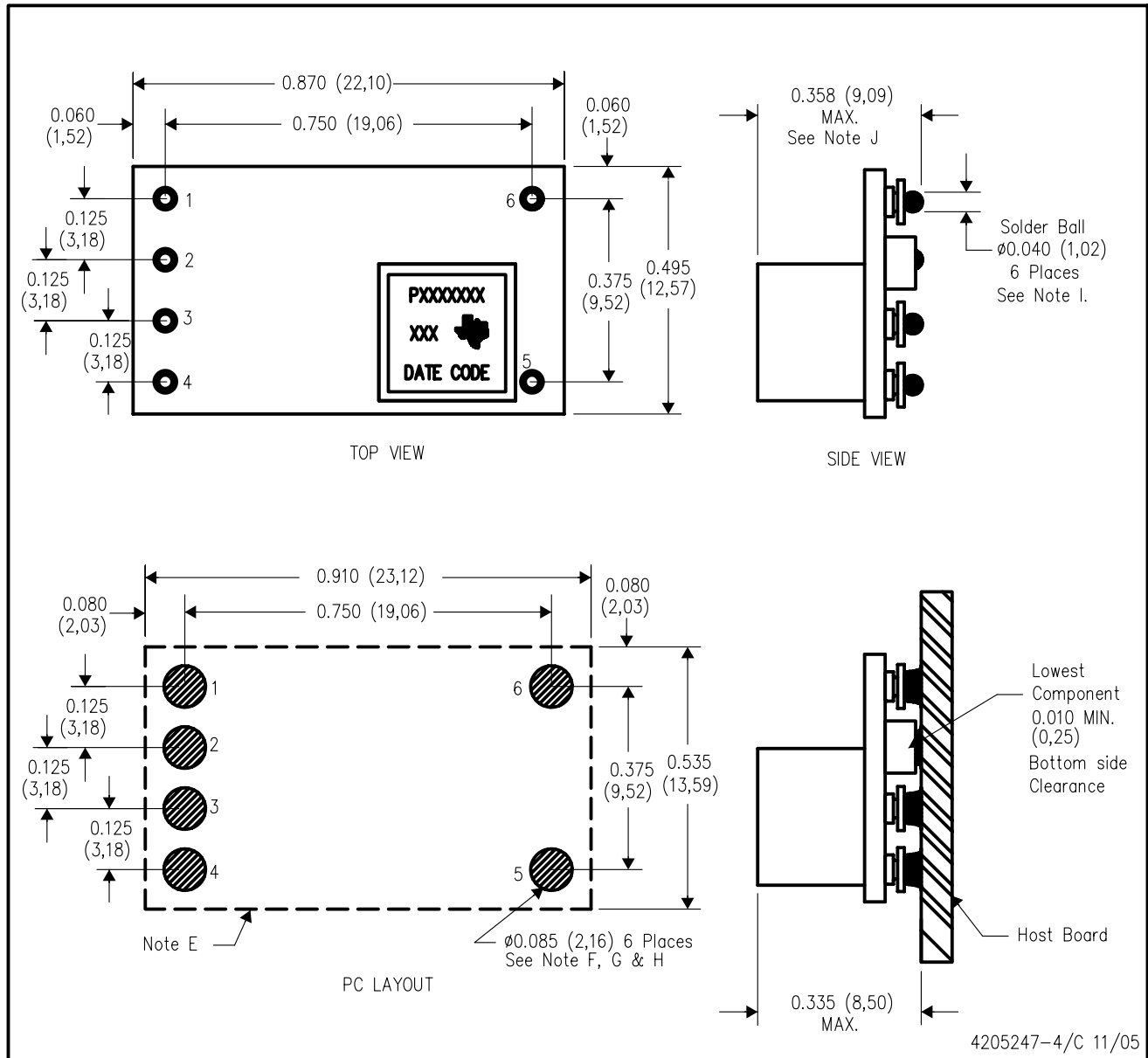

- NOTES:
- A. All linear dimensions are in inches (mm).
 - B. This drawing is subject to change without notice.
 - C. 2 place decimals are ± 0.030 ($\pm 0,76$ mm).
 - D. 3 place decimals are ± 0.010 ($\pm 0,25$ mm).
 - E. Recommended keep out area for user components.
 - F. Power pin connection should utilize two or more vias to the interior power plane of 0.025 (0,63) I.D. per input, ground and output pin (or the electrical equivalent).

- G. Paste screen opening: 0.080 (2,03) to 0.085 (2,16).
Paste screen thickness: 0.006 (0,15).
- H. Pad type: Solder mask defined.
- I. All pins: Material – Copper Alloy
Finish – Tin (100%) over Nickel plate
Solder Ball – See product data sheet.
- J. Dimension prior to reflow solder.

IMPORTANT NOTICE

Texas Instruments Incorporated (TI) reserves the right to make corrections, enhancements, improvements and other changes to its semiconductor products and services per JESD46, latest issue, and to discontinue any product or service per JESD48, latest issue. Buyers should obtain the latest relevant information before placing orders and should verify that such information is current and complete.

TI's published terms of sale for semiconductor products (<http://www.ti.com/sc/docs/stdterms.htm>) apply to the sale of packaged integrated circuit products that TI has qualified and released to market. Additional terms may apply to the use or sale of other types of TI products and services.

Reproduction of significant portions of TI information in TI data sheets is permissible only if reproduction is without alteration and is accompanied by all associated warranties, conditions, limitations, and notices. TI is not responsible or liable for such reproduced documentation. Information of third parties may be subject to additional restrictions. Resale of TI products or services with statements different from or beyond the parameters stated by TI for that product or service voids all express and any implied warranties for the associated TI product or service and is an unfair and deceptive business practice. TI is not responsible or liable for any such statements.

Buyers and others who are developing systems that incorporate TI products (collectively, "Designers") understand and agree that Designers remain responsible for using their independent analysis, evaluation and judgment in designing their applications and that Designers have full and exclusive responsibility to assure the safety of Designers' applications and compliance of their applications (and of all TI products used in or for Designers' applications) with all applicable regulations, laws and other applicable requirements. Designer represents that, with respect to their applications, Designer has all the necessary expertise to create and implement safeguards that (1) anticipate dangerous consequences of failures, (2) monitor failures and their consequences, and (3) lessen the likelihood of failures that might cause harm and take appropriate actions. Designer agrees that prior to using or distributing any applications that include TI products, Designer will thoroughly test such applications and the functionality of such TI products as used in such applications.

TI's provision of technical, application or other design advice, quality characterization, reliability data or other services or information, including, but not limited to, reference designs and materials relating to evaluation modules, (collectively, "TI Resources") are intended to assist designers who are developing applications that incorporate TI products; by downloading, accessing or using TI Resources in any way, Designer (individually or, if Designer is acting on behalf of a company, Designer's company) agrees to use any particular TI Resource solely for this purpose and subject to the terms of this Notice.

TI's provision of TI Resources does not expand or otherwise alter TI's applicable published warranties or warranty disclaimers for TI products, and no additional obligations or liabilities arise from TI providing such TI Resources. TI reserves the right to make corrections, enhancements, improvements and other changes to its TI Resources. TI has not conducted any testing other than that specifically described in the published documentation for a particular TI Resource.

Designer is authorized to use, copy and modify any individual TI Resource only in connection with the development of applications that include the TI product(s) identified in such TI Resource. NO OTHER LICENSE, EXPRESS OR IMPLIED, BY ESTOPPEL OR OTHERWISE TO ANY OTHER TI INTELLECTUAL PROPERTY RIGHT, AND NO LICENSE TO ANY TECHNOLOGY OR INTELLECTUAL PROPERTY RIGHT OF TI OR ANY THIRD PARTY IS GRANTED HEREIN, including but not limited to any patent right, copyright, mask work right, or other intellectual property right relating to any combination, machine, or process in which TI products or services are used. Information regarding or referencing third-party products or services does not constitute a license to use such products or services, or a warranty or endorsement thereof. Use of TI Resources may require a license from a third party under the patents or other intellectual property of the third party, or a license from TI under the patents or other intellectual property of TI.

TI RESOURCES ARE PROVIDED "AS IS" AND WITH ALL FAULTS. TI DISCLAIMS ALL OTHER WARRANTIES OR REPRESENTATIONS, EXPRESS OR IMPLIED, REGARDING RESOURCES OR USE THEREOF, INCLUDING BUT NOT LIMITED TO ACCURACY OR COMPLETENESS, TITLE, ANY EPIDEMIC FAILURE WARRANTY AND ANY IMPLIED WARRANTIES OF MERCHANTABILITY, FITNESS FOR A PARTICULAR PURPOSE, AND NON-INFRINGEMENT OF ANY THIRD PARTY INTELLECTUAL PROPERTY RIGHTS. TI SHALL NOT BE LIABLE FOR AND SHALL NOT DEFEND OR INDEMNIFY DESIGNER AGAINST ANY CLAIM, INCLUDING BUT NOT LIMITED TO ANY INFRINGEMENT CLAIM THAT RELATES TO OR IS BASED ON ANY COMBINATION OF PRODUCTS EVEN IF DESCRIBED IN TI RESOURCES OR OTHERWISE. IN NO EVENT SHALL TI BE LIABLE FOR ANY ACTUAL, DIRECT, SPECIAL, COLLATERAL, INDIRECT, PUNITIVE, INCIDENTAL, CONSEQUENTIAL OR EXEMPLARY DAMAGES IN CONNECTION WITH OR ARISING OUT OF TI RESOURCES OR USE THEREOF, AND REGARDLESS OF WHETHER TI HAS BEEN ADVISED OF THE POSSIBILITY OF SUCH DAMAGES.

Unless TI has explicitly designated an individual product as meeting the requirements of a particular industry standard (e.g., ISO/TS 16949 and ISO 26262), TI is not responsible for any failure to meet such industry standard requirements.

Where TI specifically promotes products as facilitating functional safety or as compliant with industry functional safety standards, such products are intended to help enable customers to design and create their own applications that meet applicable functional safety standards and requirements. Using products in an application does not by itself establish any safety features in the application. Designers must ensure compliance with safety-related requirements and standards applicable to their applications. Designer may not use any TI products in life-critical medical equipment unless authorized officers of the parties have executed a special contract specifically governing such use. Life-critical medical equipment is medical equipment where failure of such equipment would cause serious bodily injury or death (e.g., life support, pacemakers, defibrillators, heart pumps, neurostimulators, and implantables). Such equipment includes, without limitation, all medical devices identified by the U.S. Food and Drug Administration as Class III devices and equivalent classifications outside the U.S.

TI may expressly designate certain products as completing a particular qualification (e.g., Q100, Military Grade, or Enhanced Product). Designers agree that it has the necessary expertise to select the product with the appropriate qualification designation for their applications and that proper product selection is at Designers' own risk. Designers are solely responsible for compliance with all legal and regulatory requirements in connection with such selection.

Designer will fully indemnify TI and its representatives against any damages, costs, losses, and/or liabilities arising out of Designer's non-compliance with the terms and provisions of this Notice.