

HIGH-SPEED RAIL-TO-RAIL OUTPUT VIDEO AMPLIFIERS

FEATURES

- High Speed
 - 100 MHz Bandwidth (–3 dB, G = 2)
 - 900 V/s Slew Rate
- Excellent Video Performance
 - 50 MHz Bandwidth (0.1 dB, G = 2)
 - 0.007% Differential Gain
 - 0.007 Differential Phase
- Rail-to-Rail Output Swing
 - $V_O = -4.5 / 4.5$ ($R_L = 150 \Omega$)
- High Output Drive, $I_O = 100$ mA (typ)
- Ultralow Distortion
 - HD2 = –78 dBc ($f = 5$ MHz, $R_L = 150 \Omega$)
 - HD3 = –85 dBc ($f = 5$ MHz, $R_L = 150 \Omega$)
- Wide Range of Power Supplies
 - $V_S = 3$ V to 15 V

APPLICATIONS

- Video Line Driver
- Imaging
- DVD / CD ROM
- Active Filtering
- General Purpose Signal Chain Conditioning

DESCRIPTION

The SN1050x family is a set of rail-to-rail output single, dual, and triple low-voltage, high-output swing, low-distortion high-speed amplifiers ideal for driving data converters, video switching, or low distortion applications. This family of voltage-feedback amplifiers can operate from a single 15-V power supply down to a single 3-V power supply while consuming only 14 mA of quiescent current per channel. In addition, the family offers excellent ac performance with 100-MHz bandwidth, 900-V/ μ s slew rate and harmonic distortion (THD) at –78 dBc at 5 MHz.

DEVICE	DESCRIPTION
SN10501	Single
SN10502	Dual
SN10503	Triple

VIDEO DRIVE CIRCUIT

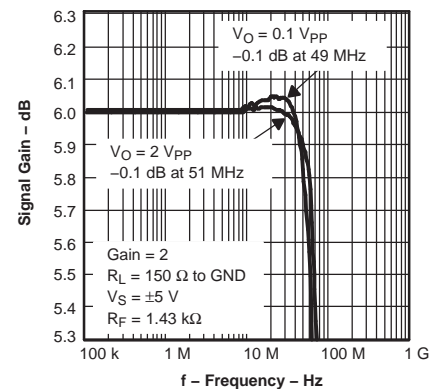
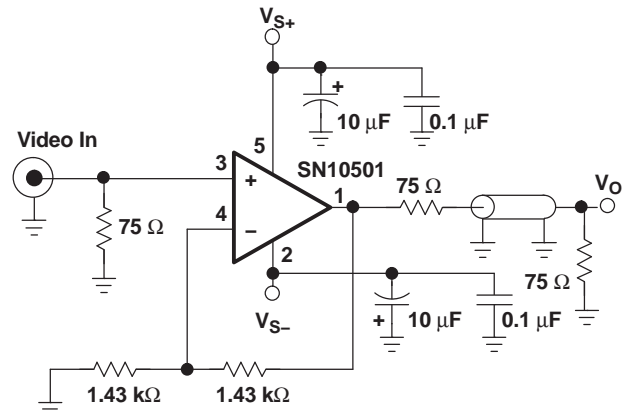

Please be aware that an important notice concerning availability, standard warranty, and use in critical applications of Texas Instruments semiconductor products and disclaimers thereto appears at the end of this data sheet.

PowerPAD is a trademark of Texas Instruments.



This integrated circuit can be damaged by ESD. Texas Instruments recommends that all integrated circuits be handled with appropriate precautions. Failure to observe proper handling and installation procedures can cause damage.

ESD damage can range from subtle performance degradation to complete device failure. Precision integrated circuits may be more susceptible to damage because very small parametric changes could cause the device not to meet its published specifications.

ABSOLUTE MAXIMUM RATINGS

operating free-air temperature range unless otherwise ⁽¹⁾

	UNIT
Supply voltage, V_S	16.5 V
Input voltage, V_I	$\pm V_S$
Output current, I_O	150 mA
Differential input voltage, V_{ID}	4 V
Continuous power dissipation See Dissipation Rating Table	
Maximum junction temperature, T_J	150°C
Maximum junction temperature, continuous operation, longterm reliability, $T_J^{(2)}$	125°C
Storage temperature range, T_{stg}	-65°C to 150°C
Lead temperature 1,6 mm (1/16 inch) from case for 10 seconds	300°C

- (1) The absolute maximum ratings under any condition is limited by the constraints of the silicon process. Stresses above these ratings may cause permanent damage. Exposure to absolute maximum conditions for extended periods may degrade device reliability. These are stress ratings only, and functional operation of the device at these or any other conditions beyond those specified is not implied.
- (2) The maximum junction temperature for continuous operation is limited by package constraints. Operation above this temperature may result in reduced reliability and/or lifetime of the device.

PACKAGE DISSIPATION RATINGS

PACKAGE	$\theta_{JC}(^{\circ}C/W)^{(1)}$	$\theta_{JA}(^{\circ}C/W)$	POWER RATING ⁽²⁾	
			$T_A \leq 25^{\circ}C$	$T_A = 85^{\circ}C$
DBV (5)	55	255.4	391 mW	156 mW
D (8)	38.3	97.5	1.02 W	410 mW
D (14)	26.9	66.6	1.5 W	600 mW
DGK (8)	54.2	260	385 mW	154 mW
DGN (8) ⁽³⁾	4.7	58.4	1.71 W	685 mW
PWP (14) ⁽³⁾	2.07	37.5	2.67 W	1.07 W

- (1) This data was taken using the JEDEC standard High-K test PCB.
- (2) Power rating is determined with a junction temperature of 125°C. This is the point where distortion starts to substantially increase. Thermal management of the final PCB should strive to keep the junction temperature at or below 125°C for best performance and long term reliability.
- (3) The SN10501, SN10502, and SN10503 may incorporate a PowerPAD™ on the underside of the chip. This acts as a heatsink and must be connected to a thermally dissipating plane for proper power dissipation. Failure to do so may result in exceeding the maximum junction temperature which could permanently damage the device. See TI Technical Brief [SLMA002](#) for more information about utilizing the PowerPAD™ thermally enhanced package.

RECOMMENDED OPERATING CONDITIONS

		MIN	MAX	UNIT
Supply voltage, (V _{S+} and V _{S-})	Dual supply	1.35	8	V
	Single supply	2.7	16	
Input common-mode voltage range		V _{S-} + 1.1	V _{S+} - 1.1	V

PACKAGE ORDERING INFORMATION

PACKAGED DEVICES			PACKAGE TYPE	TRANSPORT MEDIA, QUANTITY
SINGLE	DUAL	TRIPLE		
SN10501DBVT	—	—	SOT-23-5	Tape and Reel, 250
SN10501DBVR	—	—	SOT-23-5	Tape and Reel, 3000
SN10501DGK	SN10502DGK	—	MSOP-8	Rails, 75
SN10501DGKR	SN10502DGKR	—	MSOP-8	Tape and Reel, 2500
SN10501DGN	SN10502DGN	—	MSOP-8-PP	Rails, 75
SN10501DGNR	SN10502DGNR	—	MSOP-8-PP	Tape and Reel, 2500
SN10501D	SN10502D	SN10503D	SOIC	Rails, 75
SN10501DR	SN10502DR	SN10503DR	SOIC	Tape and Reel, 2500
—	—	SN10503PWP	TSSOP-14-PP	Rails, 75
—	—	SN10503PWPR	TSSOP-14-PP	Tape and Reel, 2000

PIN ASSIGNMENTS

PACKAGE DEVICES

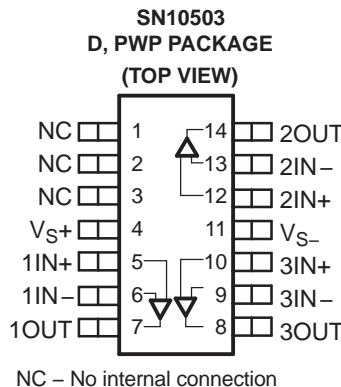
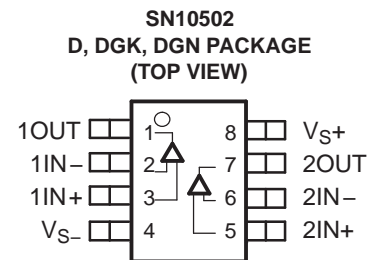
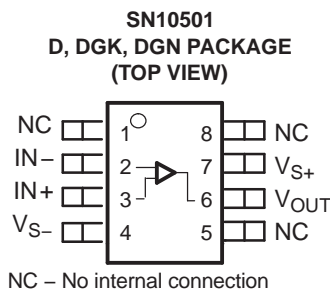
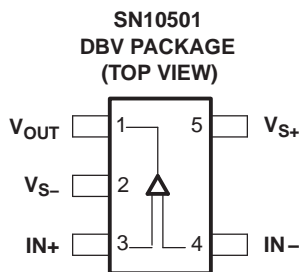

ELECTRICAL CHARACTERISTICS

$V_S = 5\text{ V}$, $R_L = 150\ \Omega$, and $G = 2$ unless otherwise noted

PARAMETER	TEST CONDITIONS	TYP	OVER TEMPERATURE				UNITS	MIN/MAX
		25°C	25°C	0°C to 70°C	-40°C to 85°C			
AC PERFORMANCE								
Small signal bandwidth	$G = 1, V_O = 100\text{ mV}_{PP}$	170					MHz	Typ
	$G = 2, V_O = 100\text{ mV}_{PP}, R_f = 1\text{ k}\Omega$	100					MHz	Typ
	$G = 10, V_O = 100\text{ mV}_{PP}, R_f = 1\text{ k}\Omega$	12					MHz	Typ
0.1 dB flat bandwidth	$G = 2, V_O = 100\text{ mV}_{PP}, R_f = 1.43\text{ k}\Omega$	50					MHz	Typ
Gain bandwidth product	$G > 10, f = 1\text{ MHz}, R_f = 1\text{ k}\Omega$	120					MHz	Typ
Full-power bandwidth ⁽¹⁾	$G = 2, V_O = \pm 2.5\text{ V}_{PP}$	57					MHz	Typ
Slew rate	$G = 2, V_O = \pm 2.5\text{ V}_{PP}$	900					V/ μs	Min
Settling time to 0.1%	$G = -2, V_O = \pm 2\text{ V}_{PP}$	25					ns	Typ
Settling time to 0.01%		52					ns	Typ
Harmonic distortion								
Second harmonic distortion	$G = 2, V_O = 2\text{ V}_{PP}, f = 5\text{ MHz}, R_L = 150\ \Omega$	-78					dBc	Typ
Third harmonic distortion		-85					dBc	Typ
Differential gain (NTSC, PAL)	$G = 2, R = 150\ \Omega$	0.007					%	Typ
Differential phase (NTSC, PAL)		0.007					°	Typ
Input voltage noise	$f = 1\text{ MHz}$	13					nV/ $\sqrt{\text{Hz}}$	Typ
Input current noise		0.8					pA/ $\sqrt{\text{Hz}}$	Typ
Crosstalk (dual and triple only)	$f = 5\text{ MHz Ch-to-Ch}$	-90					dB	Typ
DC PERFORMANCE								
Open-loop voltage gain (A_{OL})	$V_O = \pm 2\text{ V}$	100	80	75	75		dB	Min
Input offset voltage	$V_{CM} = 0\text{ V}$	12	25	30	30		mV	Max
Input bias current		0.9	3	5	5		μA	Max
Input offset current		100	500	700	700		nA	Max
INPUT CHARACTERISTICS								
Common-mode input range		-4 / 4	-3.9 / 3.9				V	Min
Common-mode rejection ratio	$V_{CM} = 2\text{ V}$	94	70	65	65		dB	Min
Input resistance		33					M Ω	Typ
Input capacitance	Common-mode / differential	1 / 0.5					pF	Max
OUTPUT CHARACTERISTICS								
Output voltage swing	$R_L = 150\ \Omega$	-4.5 / 4.5					V	Typ
	$R_L = 499\ \Omega$	-4.7 / 4.7	-4.5 / 4.5	-4.4 / 4.4	-4.4 / 4.4		V	Min
Output current (sourcing)	$R_L = 10\ \Omega$	100	92	88	88		mA	Min
Output current (sinking)		-100	-92	-88	-88		mA	Min
Output impedance	$f = 1\text{ MHz}$	0.09					Ω	Typ
POWER SUPPLY								
Specified operating voltage		± 5	± 8	± 8	± 8		V	Max
Maximum quiescent current	Per channel	14	18	20	22		mA	Max
Power supply rejection ($\pm\text{PSRR}$)		75	62	60	60		dB	Min

(1) Full-power bandwidth = $SR / 2\pi V_{pp}$

ELECTRICAL CHARACTERISTICS

 $V_S = 5\text{ V}$, $R_L = 150\ \Omega$, and $G = 2$ unless otherwise noted

PARAMETER	TEST CONDITIONS	TYP	OVER TEMPERATURE				UNITS	MIN/MAX
		25°C	25°C	0°C to 70C	-40°C to 85C			
AC PERFORMANCE								
Small signal bandwidth	$G = 1$, $V_O = 100\text{ mV}_{PP}$	170					MHz	Typ
	$G = 2$, $V_O = 100\text{ mV}_{PP}$, $R_f = 1.5\text{ k}\Omega$	100					MHz	Typ
	$G = 10$, $V_O = 100\text{ mV}_{PP}$, $R_f = 1.5\text{ k}\Omega$	12					MHz	Typ
0.1 dB flat bandwidth	$G = 2$, $V_O = 100\text{ mV}_{PP}$, $R_f = 1.24\text{ k}\Omega$	50					MHz	Typ
Gain bandwidth product	$G > 10$, $f = 1\text{ MHz}$, $R_f = 1.5\text{ k}\Omega$	120					MHz	Typ
Full-power bandwidth ⁽¹⁾	$G = 2$, $V_O = 4\text{ V}$ step	60					MHz	Typ
Slew rate		750					V/ μ s	Min
Settling time to 0.1%	$G = -2$, $V_O = 2\text{ V}$	27					ns	Typ
Settling time to 0.01%		48					ns	Typ
Harmonic distortion								
Second harmonic distortion	$G = 2$, $V_O = 2\text{ V}_{PP}$, $f = 5\text{ MHz}$, $R_L = 150\ \Omega$	-82					dBc	Typ
Third harmonic distortion		-88					dBc	Typ
Differential gain (NTSC, PAL)	$G = 2$, $R = 150\ \Omega$	0.014					%	Typ
Differential phase (NTSC, PAL)		0.011					°	Typ
Input voltage noise	$f = 1\text{ MHz}$	13					nV/ $\sqrt{\text{Hz}}$	Typ
Input current noise		0.8					pA/ $\sqrt{\text{Hz}}$	Typ
Crosstalk (dual and triple only)	$f = 5\text{ MHz}$ Ch-to-Ch	-90					dB	Typ
DC PERFORMANCE								
Open-loop voltage gain (A_{OL})	$V_O = 1.5\text{ V}$ to 3.5 V	100	80	75	75		dB	Min
Input offset voltage	$V_{CM} = 2.5\text{ V}$	12	25	30	30		mV	Max
Input bias current		0.9	3	5	5		μ A	Max
Input offset current		100	500	700	700		nA	Max
INPUT CHARACTERISTICS								
Common-mode input range		1 / 4	1.1 / 3.9				V	Min
Common-mode rejection ratio	$V_{CM} = 1.5\text{ V}$ to 3.5 V	96	70	65	65		dB	Min
Input resistance		33					M Ω	Typ
Input capacitance	Common-mode / differential	1 / 0.5					pF	Max
OUTPUT CHARACTERISTICS								
Output voltage swing	$R_L = 150\ \Omega$	0.5 / 4.5					V	Typ
	$R_L = 499\ \Omega$	0.2 / 4.8	0.3 / 4.7	0.4 / 4.6	0.4 / 4.6		V	Min
Output current (sourcing)	$R_L = 10\ \Omega$	95	85	80	80		mA	Min
Output current (sinking)		-95	-85	-80	-80		mA	Min
Output impedance	$f = 1\text{ MHz}$	0.09					Ω	Typ
POWER SUPPLY								
Specified operating voltage		5	16	16	16		V	Max
Maximum quiescent current	Per channel	12	15	17	19		mA	Max
Power supply rejection (\pm PSRR)		70	62	60	60		dB	Min

 (1) Full-power bandwidth = $SR / 2\pi V_{pp}$

TYPICAL CHARACTERISTICS

TABLE OF GRAPHS

		FIGURE
Frequency response		1– 8
Small signal frequency response		9, 10
Large signal frequency response		11
Slew rate	vs Output voltage step	12, 13
Harmonic distortion	vs Frequency	14, 15
Voltage and current noise	vs Frequency	16
Differential gain	vs Number of loads	17, 18
Differential phase	vs Number of loads	19, 20
Quiescent current	vs Supply voltage	21
Output voltage	vs Load resistance	22
Open-loop gain and phase	vs Frequency	23
Rejection ratio	vs Frequency	24
Rejection ratio	vs Case temperature	25
Common-mode rejection ratio	vs Input common-mode range	26, 27
Output impedance	vs Frequency	28, 29
Crosstalk	vs Frequency	30
Input bias and offset current	vs Case temperature	31, 32

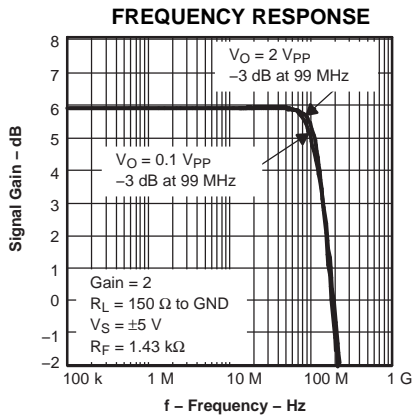

Figure 1.

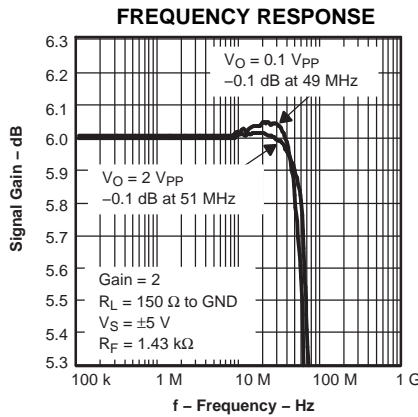

Figure 2.

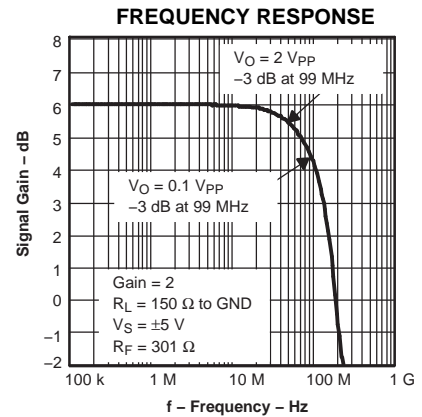

Figure 3.

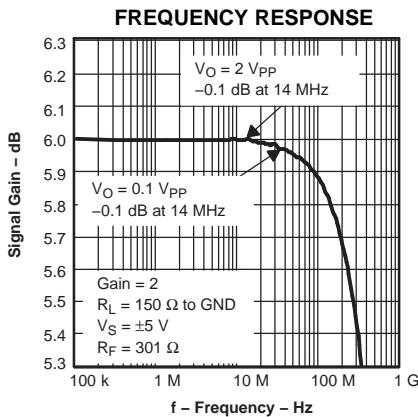

Figure 4.

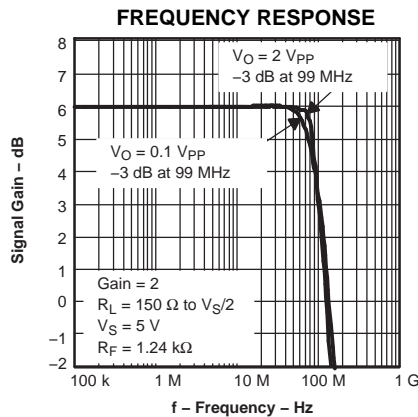

Figure 5.

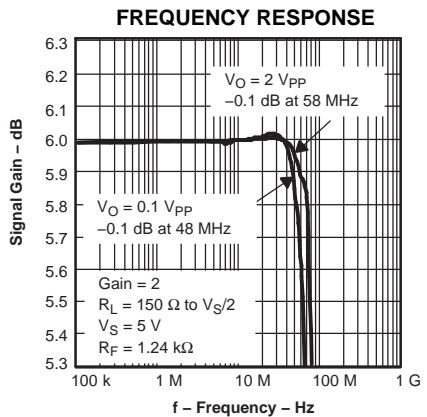

Figure 6.

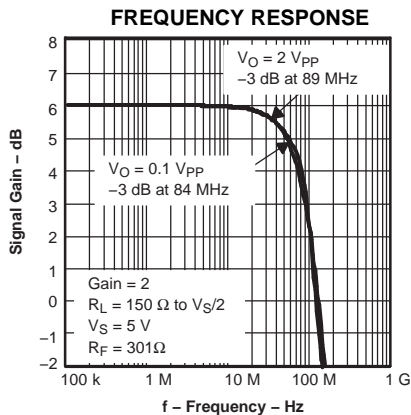

Figure 7.

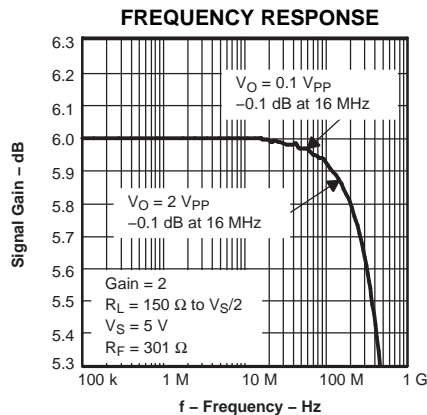

Figure 8.

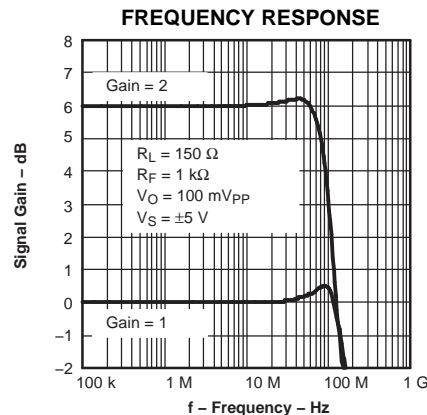

Figure 9.

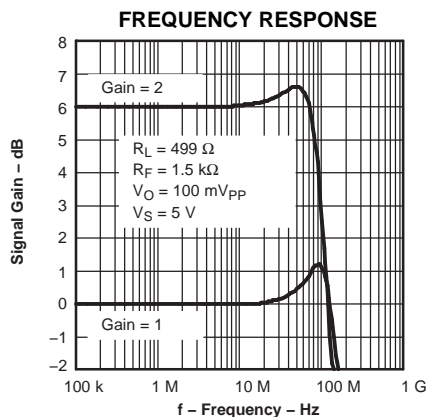

Figure 10.

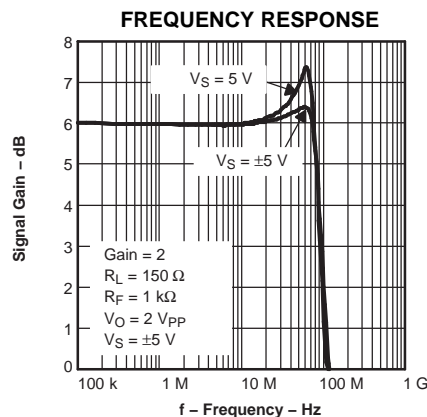

Figure 11.

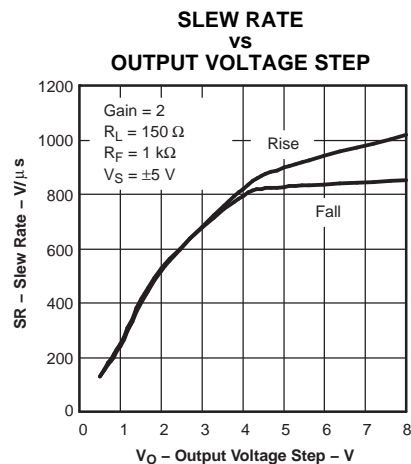

Figure 12.

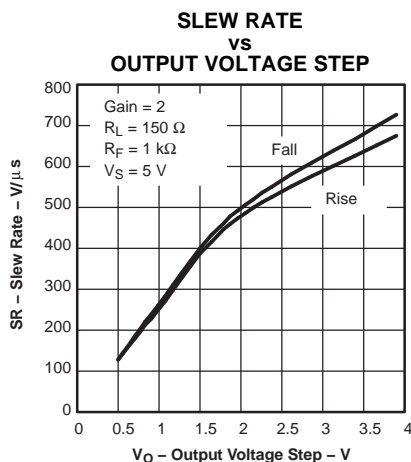

Figure 13.

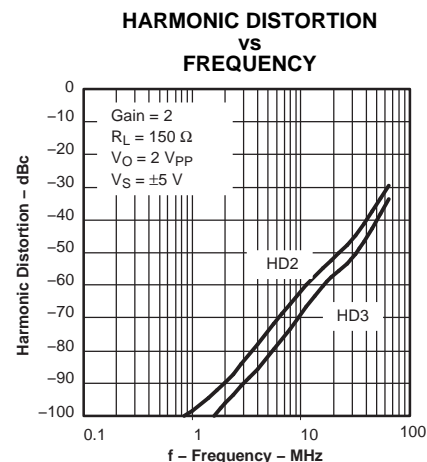

Figure 14.

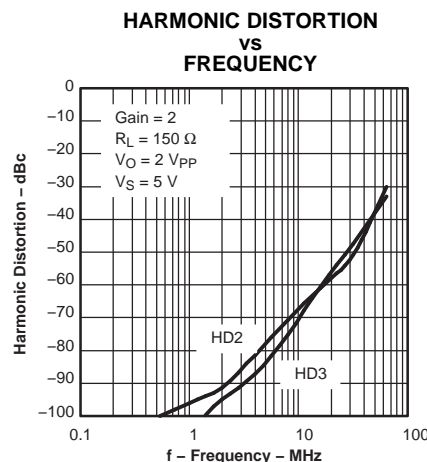

Figure 15.

VOLTAGE AND CURRENT NOISE
VS
FREQUENCY

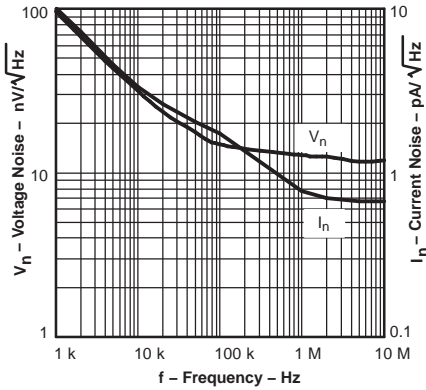

Figure 16.

DIFFERENTIAL GAIN
VS
NUMBER OF LOADS

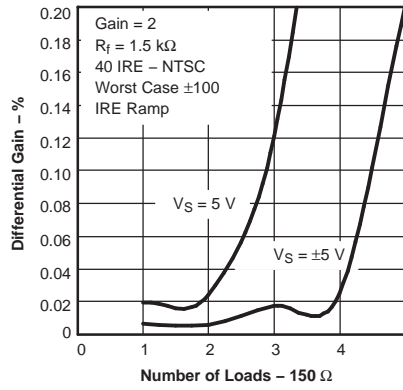

Figure 17.

DIFFERENTIAL PHASE
VS
NUMBER OF LOADS

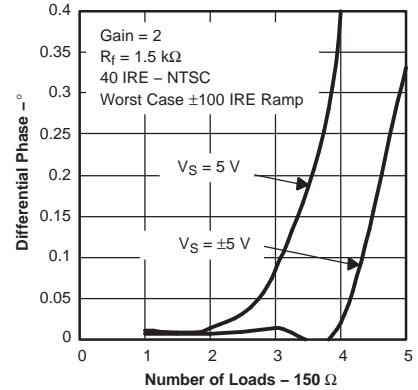

Figure 18.

DIFFERENTIAL GAIN
VS
NUMBER OF LOADS

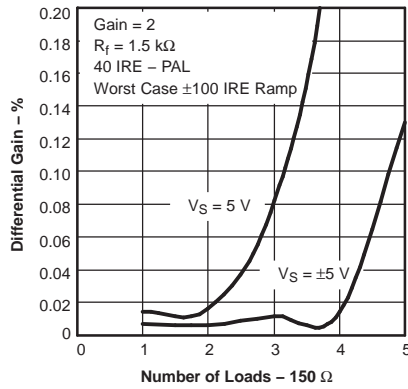

Figure 19.

DIFFERENTIAL PHASE
VS
NUMBER OF LOADS

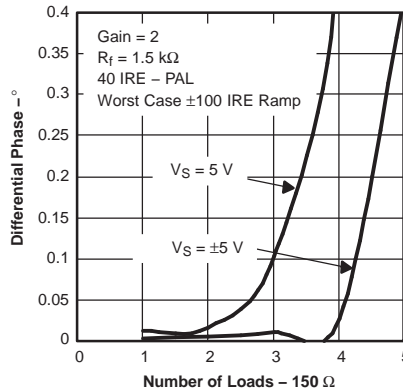

Figure 20.

QUIESCENT CURRENT
VS
SUPPLY VOLTAGE

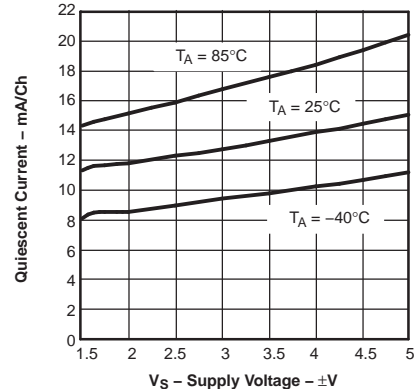

Figure 21.

OUTPUT VOLTAGE
VS
LOAD RESISTANCE

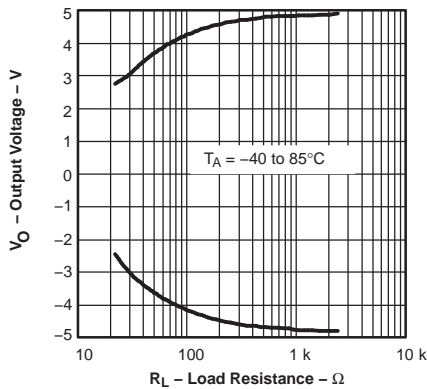

Figure 22.

OPEN-LOOP GAIN AND PHASE
VS
FREQUENCY

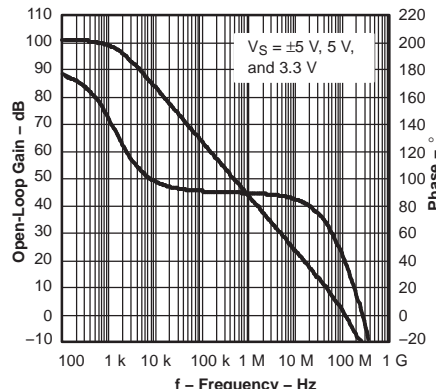

Figure 23.

REJECTION RATIO
VS
FREQUENCY

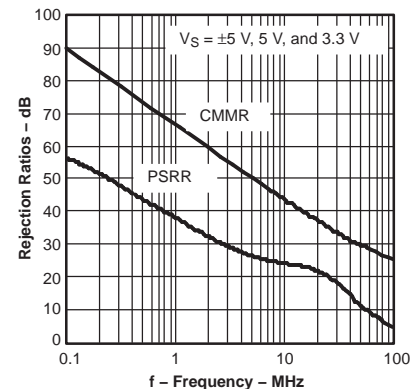

Figure 24.

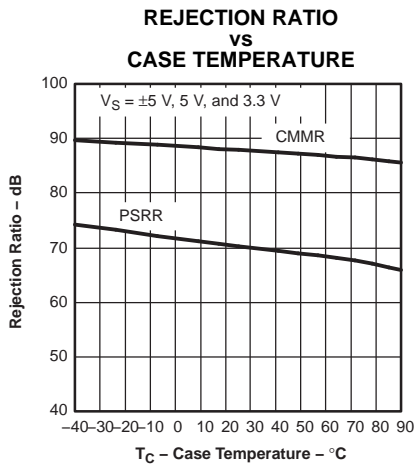

Figure 25.

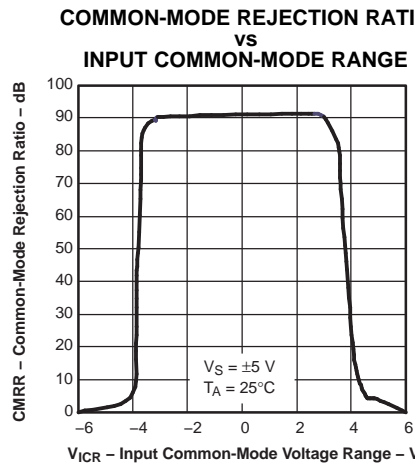

Figure 26.

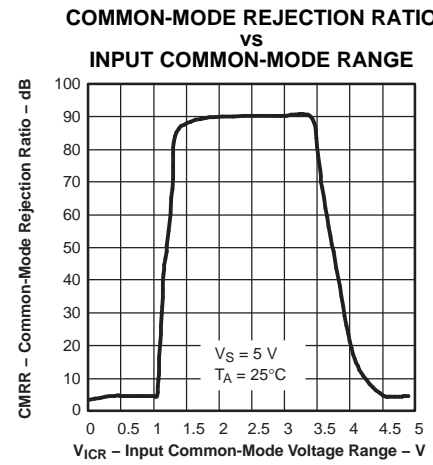

Figure 27.

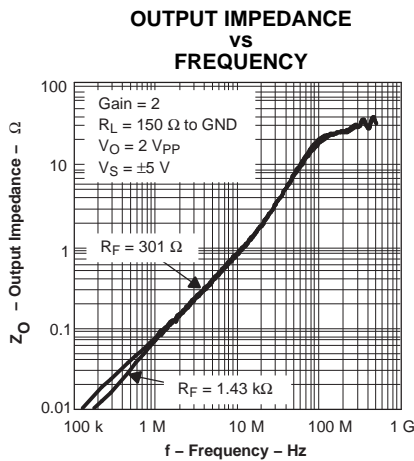

Figure 28.

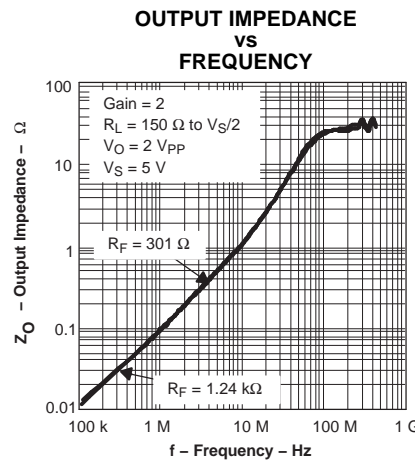

Figure 29.

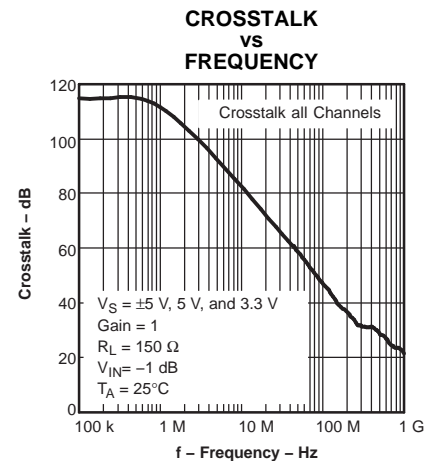

Figure 30.

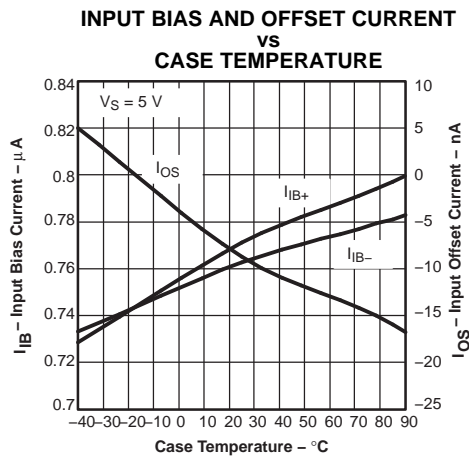

Figure 31.

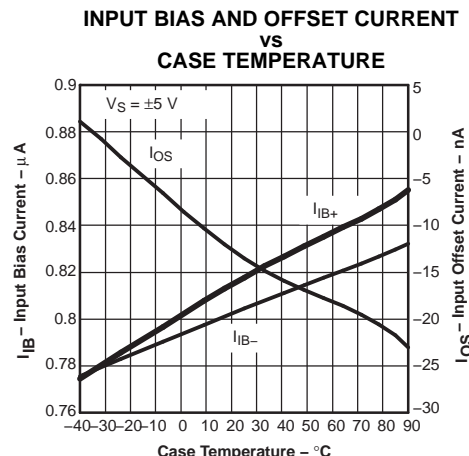

Figure 32.

APPLICATION INFORMATION

HIGH-SPEED OPERATIONAL AMPLIFIERS

The SN1050x operational amplifiers are a family of single, dual, and triple rail-to-rail output voltage feedback amplifiers. The SN1050x family combines both a high slew rate and a rail-to-rail output stage.

Applications Section Contents

- Wideband, Noninverting Operation
- Wideband, Inverting Gain Operation
- Video Drive Circuits
- Single Supply Operation
- Power Supply Decoupling Techniques and Recommendations
- Active Filtering With the SN1050x
- Driving Capacitive Loads
- Board Layout
- Thermal Analysis
- Additional Reference Material
- Mechanical Package Drawings

WIDEBAND, NONINVERTING OPERATION

The SN1050x is a family of unity gain stable rail-to-rail output voltage feedback operational amplifiers designed to operate from a single 3-V to 15-V power supply.

Figure 33 is the noninverting gain configuration of 2V/V used to demonstrate the typical performance curves.

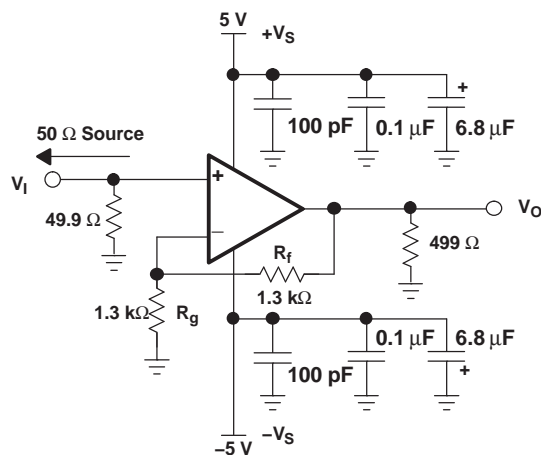

Figure 33. Wideband, Noninverting Gain Configuration

Voltage-feedback amplifiers, unlike current-feedback designs, can use a wide range of resistors values to set their gain with minimal impact on their stability and frequency response. Larger-valued resistors

decrease the loading effect of the feedback network on the output of the amplifier, but this enhancement comes at the expense of additional noise and potentially lower bandwidth. Feedback-resistor values between 1 k Ω and 2 k Ω are recommended for most situations.

WIDEBAND, INVERTING OPERATION

Since the SN1050x family are general-purpose, wideband voltage-feedback amplifiers, several familiar operational-amplifier applications circuits are available to the designer. Figure 34 shows a typical inverting configuration where the input and output impedances and noise gain from Figure 33 are retained in an inverting circuit configuration. Inverting operation is one of the more common requirements and offers several performance benefits. The inverting configuration shows improved slew rates and distortion due to the pseudo-static voltage maintained on the inverting input.

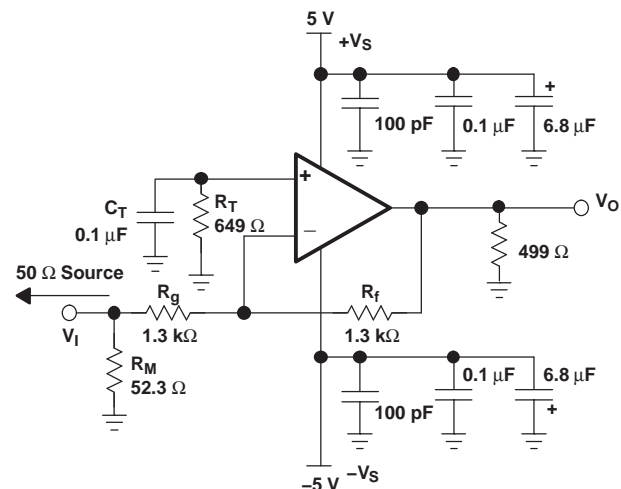

Figure 34. Wideband, Inverting Gain Configuration

In the inverting configuration, some key design considerations must be noted. One is that the gain resistor (R_g) becomes part of the signal channel input impedance. If input impedance matching is desired (beneficial when the signal is coupled through a cable, twisted pair, long PC-board trace, or other transmission-line conductors), R_g may be set equal to the required termination value and R_f adjusted to give the desired gain. However, care must be taken when dealing with low inverting gains, because the resulting feedback-resistor value can present a significant load to the amplifier output. For an inverting gain of 2, setting R_g to 49.9 Ω for input matching eliminates the need for R_M but requires a 100- Ω feedback resistor. This has the advantage that the noise gain becomes equal to 2 for a 50- Ω source impedance—the same

as the noninverting circuit in Figure 33. However, the amplifier output now sees the 100-Ω feedback resistor in parallel with the external load. To eliminate this excessive loading, increase both R_g and R_f values, as shown in Figure 34, and then provide the input-matching impedance with a third resistor (R_M) to ground. The total input impedance becomes the parallel combination of R_g and R_M .

The last major consideration to discuss in inverting amplifier design is setting the bias-current cancellation resistor on the noninverting input. If the resistance is set equal to the total dc resistance looking out of the inverting terminal, the output dc error, due to the input bias currents, is reduced to the input-offset current multiplied by R_f in Figure 34. The dc source impedance looking out of the inverting terminal is $1.3\text{ k}\Omega \parallel (1.3\text{ k}\Omega + 25.6\ \Omega) = 649\ \Omega$. To reduce the additional high-frequency noise introduced by the resistor at the noninverting input, and power-supply feedback, R_T is bypassed with a capacitor to ground.

SINGLE SUPPLY OPERATION

The SN1050x family is designed to operate from a single 3-V to 15-V power supply. When operating from a single power supply, care must be taken to ensure that the input signal and amplifier are biased appropriately to allow for the maximum output voltage swing. The circuits shown in Figure 35 demonstrate methods to configure an amplifier for single-supply operation.

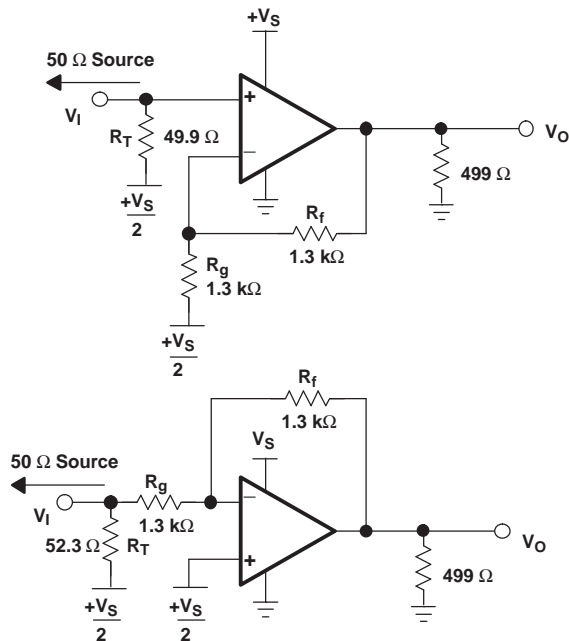

Figure 35. DC-Coupled Single Supply Operation

Video Drive Circuits

Most video-distribution systems are designed with 75-Ω series resistors to drive a matched 75-Ω cable. In order to deliver a net gain of 1 to the 75-Ω matched load, the amplifier is typically set up for a voltage gain of 2, compensating for the 6-dB attenuation of the voltage divider formed by the series and shunt 75-Ω resistors at either end of the cable. The circuit shown in Figure 36 meets this requirement. The SN1050x gain flatness and differential gain/phase performance provide exceptional results in video distribution applications.

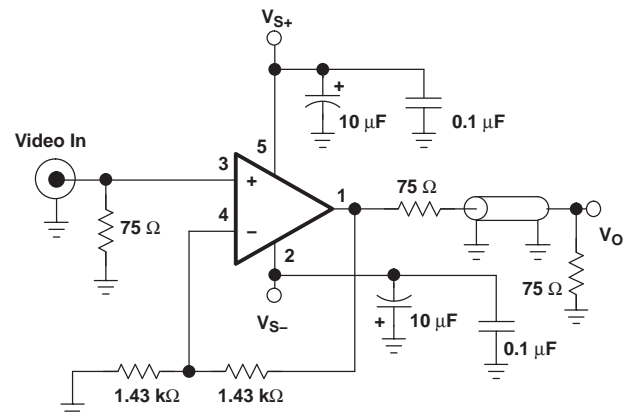

Figure 36. Cable Drive Application

Differential gain and phase measure the change in overall small-signal gain and phase for the color subcarrier frequency (3.58 MHz in NTSC systems) vs changes in the large-signal output level (which represents luminance information in a composite video signal). The SN1050x, with the typical 150-Ω load of a single matched video cable, shows less than 0.007% / 0.007° differential gain/phase errors over the standard luminance range for a positive video (negative sync) signal.

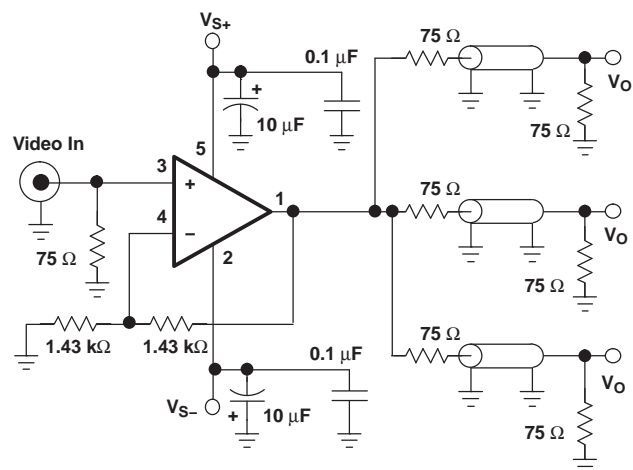

Figure 37. Video Distribution

Similar performance is observed for negative video signals. In practice, similar performance is achieved even with three video loads as shown in Figure 37 due to the linear high-frequency output impedance of the SN1050x. This circuit is suitable for driving video cables, provided that the length does not exceed a few feet. If longer cables are driven, the gain of the SN1050x can be increased to compensate for cable loss.

Configuring the SN1050x for single-supply video applications is easily done, but attention must be given to input and output bias voltages to ensure proper system operation. Unlike some video amplifiers, the SN1050x input common-mode voltage range does not include the negative power supply, but rather it is about 1-V from each power supply. For split supply configurations, this is very beneficial. For single-supply systems, there are some design constraints that must be observed.

Figure 38 shows a single-supply video configuration illustrating the dc bias voltages acceptable for the SN1050x. The lower end of the input common-mode range is specified as 1 V. The upper end is limited to 4 V with the 5-V supply shown, but the output range and gain of 2 limit the highest acceptable input voltage to $4.5 \text{ V} / 2 = 2.25 \text{ V}$. The 4.5-V output is what is typically expected with a 150- Ω load. It is easily seen that the input and output voltage ranges are limiting factors in the total system. Both specifications must be taken into account when designing a system.

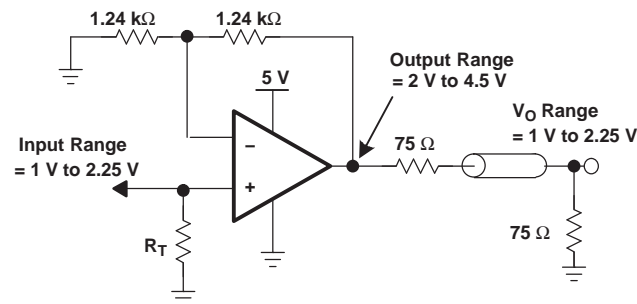

Figure 38. DC-Coupled Single-Supply Video Amplifier

In most systems, this may be acceptable because most receivers are ac-coupled and set the black level to the desired system value, typically 0 V (0-IRE). But, to ensure full compatibility with any system, it is often desirable to place an ac coupling capacitor on the output as shown in Figure 39. This removes the dc-bias voltage appearing at the amplifier output. To minimize field tilt, the size of this capacitor is typically 470 μF , although values as small as 220 μF have been used with acceptable results.

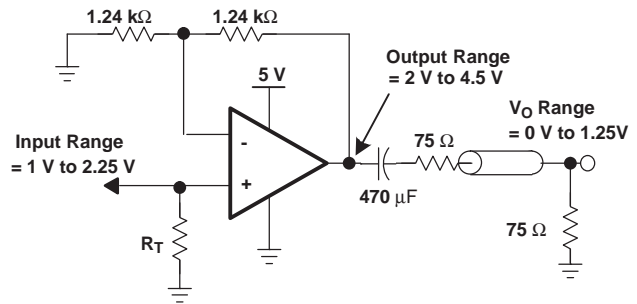

Figure 39. AC-Coupled Output Single-Supply Video Amplifier

In some systems, the physical size and/or cost of a 470- μF capacitor can be prohibitive. One way to circumvent this issue is to use two smaller capacitors in a feedback configuration as shown in Figure 40. This is commonly known as SAG correction. This circuit increases the gain of the amplifier up to 3 V/V at low frequencies to counteract the increased impedance of the capacitor placed at the amplifier output. One issue that must be resolved is that the gain at low frequencies is typically limited by the power-supply voltage and the output swing of the amplifier. Therefore, it is possible to saturate the amplifier at these low frequencies if full analysis is not done on this system which includes both input and output requirements.

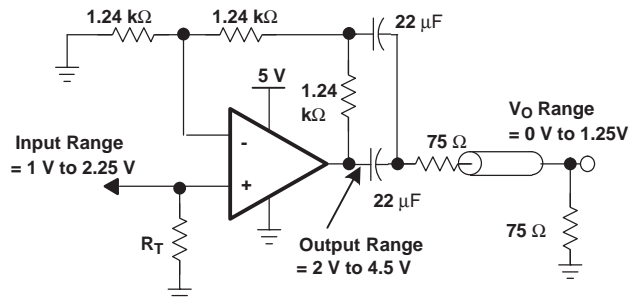

Figure 40. AC-Coupled SAG Corrected Output Single-Supply Video Amplifier

Many times the output of the video encoder or DAC does not have the capability to output the 1-V to 2.25-V range, but rather a 0-V to 1.25-V range. In this instance, the signal must be ac-coupled to the amplifier input as shown in Figure 41. Note that it does not matter what the voltage output of the DAC is, but rather the voltage swing should be kept less than $1.25 \text{ V}_{\text{PP}}$.

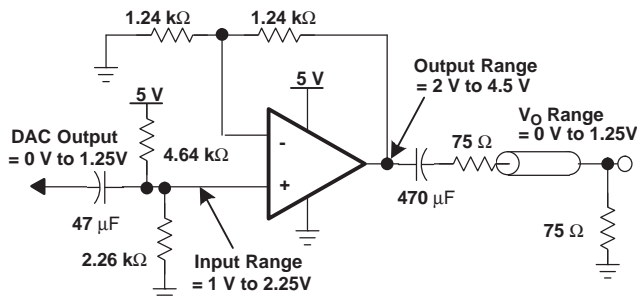

Figure 41. AC-Coupled Input and Output Single-Supply Video Amplifier

To further increase dynamic range at the output, the output dc bias should be centered around 2.5 V for the 5-V system shown. However, a wide output range requires a wide input range, and should be centered around 2.5 V. The best ways to accomplish this are to ac-couple the gain resistor or bias it at 2.5 V with a reference supply as shown in Figure 42 and Figure 43.

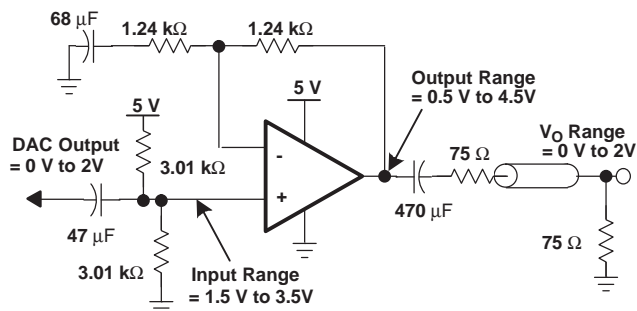

Figure 42. AC-Coupled Wide Output Swing Single-Supply Video Amplifier

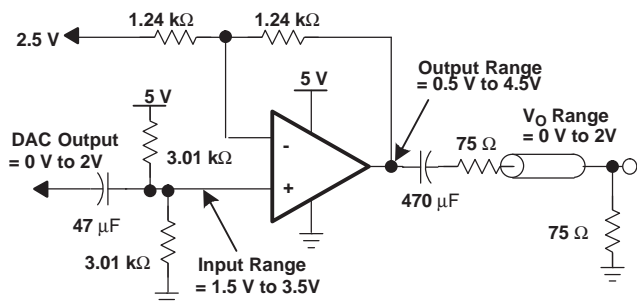

Figure 43. AC-Coupled Wide Output Swing Single-Supply Video Amplifier Using Voltage Reference

Another beneficial configuration is to use the amplifier in an inverting configuration as shown in Figure 44.

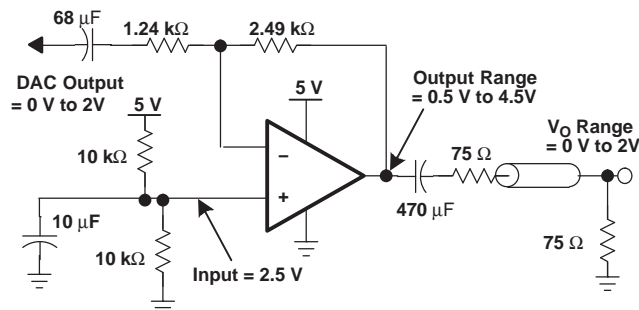

Figure 44. Inverting AC-Coupled Wide Output Swing Single-Supply Video Amplifier

APPLICATION CIRCUITS

Active Filtering With the SN1050x

High-frequency active filtering with the SN1050x is achievable due to the amplifier's high slew rate, wide bandwidth, and voltage feedback architecture. Several options are available for high-pass, low-pass, bandpass, and bandstop filters of varying orders. A simple two-pole, low-pass filter is presented in Figure 45 as an example, with two poles at 25 MHz.

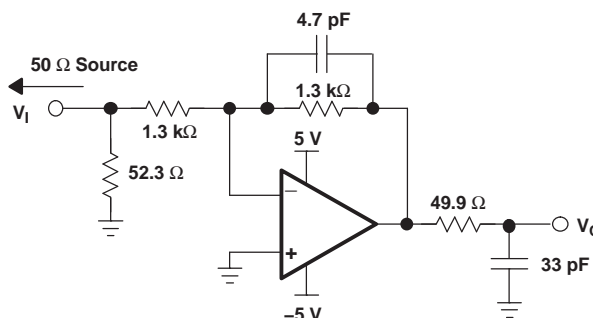

Figure 45. A Two-Pole Active Filter With Two Poles Between 90 MHz and 100 MHz

Driving Capacitive Loads

A demanding, yet very common application for an op amp is capacitive loading. Often, this load is the input of an A/D converter, including additional external capacitance, sometimes recommended to improve A/D linearity. A high-speed, high open-loop gain amplifier like the SN1050x can be very susceptible to decreased stability and closed-loop response peaking when a capacitive load is placed directly on the output pin. When the amplifier's open-loop output resistance is considered, the capacitance introduces an additional pole in the signal path that can decrease the phase margin. When the primary considerations are frequency-response flatness, pulse response fidelity, or distortion, the simplest and most effective solution is to isolate the capacitive load

from the feedback loop by inserting a series isolation resistor between the amplifier output and the capacitive load. This does not eliminate the pole from the loop response, but rather shifts it and adds a zero at a higher frequency. The additional zero cancels the phase lag from the capacitive-load pole, thus increasing the phase margin and improving stability.

Power Supply Decoupling Techniques and Recommendations

Power-supply decoupling is a critical aspect of any high-performance amplifier design process. Careful decoupling provides higher-quality ac performance, most notably improved distortion performance. The following guidelines ensure the highest level of performance.

1. Place decoupling capacitors as close to the power-supply inputs as possible, with the goal of minimizing the inductance of the path from ground to the power supply
2. Placement priority; locate the smallest-value capacitors nearest to the device.
3. Solid power and ground planes are recommended to reduce the inductance along power-supply return-current paths, with the exception of the areas underneath the input and output pins.
4. Recommended values for power supply decoupling include a bulk decoupling capacitor (6.8 to 22 μF), a mid-range decoupling capacitor (0.1 μF) and a high frequency decoupling capacitor (1000 pF) for each supply. A 100 pF capacitor can be used across the supplies as well for extremely high-frequency return currents, but often is not required.

BOARD LAYOUT

Achieving optimum performance with a high-frequency amplifier like the SN1050x requires careful attention to board layout parasitics and external component types.

Recommendations to optimize performance include:

1. **Minimize parasitic capacitance to any ac ground for all signal I/O pins.** Parasitic capacitance on the output and inverting-input pins can cause instability: on the noninverting input, it can react with the source impedance to cause unintentional band limiting. To reduce unwanted capacitance, open a window in all ground and power planes around the signal I/O pins. Keep ground and power planes unbroken elsewhere on the board.
2. **Minimize the distance (< 0.25") from the power-supply pins to high frequency 0.1- μF decoupling capacitors.** At the device pins, the

ground- and power-plane layout should not be in close proximity to the signal I/O pins. Avoid narrow power and ground traces to minimize inductance between the pins and the decoupling capacitors. The power supply connections should always be decoupled with these capacitors. Larger (2.2- μF to 6.8- μF) decoupling capacitors, effective at lower frequency, should also be used on the main supply pins. These may be placed somewhat farther from the device and may be shared among several devices in the same area of the PC board.

3. **Careful selection and placement of external components preserves the high frequency performance of the SN1050x.** Choose low-reactance resistors. Surface-mount resistors work best, and allow a tighter overall layout. Metal-film and carbon-composition axial-lead resistors can also provide good high-frequency performance. Again, keep component leads and PC-board trace length as short as possible. Never use wirewound resistors in a high frequency application. Since the output pin and inverting-input pin are the most sensitive to parasitic capacitance, always position the feedback and series-output resistor, if any, as close as possible to the output pin. Other network components, such as noninverting-input termination resistors, should also be placed close to the package. Where double-sided component mounting is allowed, place the feedback resistor directly under the package on the other side of the board between the output and inverting input pins. Even with a low parasitic capacitance shunting the external resistors, excessively high resistor values can create significant time constants that can degrade performance. Good axial-lead metal-film or surface-mount resistors have approximately 0.2 pF in shunt with the resistor. For resistor values > 2.0 k Ω , this parasitic capacitance can add a pole and/or a zero below 400 MHz that can affect circuit operation. Keep resistor values as low as possible, consistent with load-driving considerations. A good starting point for design is to set the R_f to 1.3 k Ω for low-gain, noninverting applications. This automatically keeps the resistor noise terms low, and minimizes the effect of their parasitic capacitance.
4. **Connections to other wideband devices on the board may be made with short, direct traces or through onboard transmission lines.** For short connections, consider the trace and the input to the next device as a lumped capacitive load. Use relatively wide traces (50 mils to 100 mils), preferably with ground and power planes opened up around them. Low parasitic capacitive loads (<4 pF) may not need an $R_{(ISO)}$, since the SN1050x is nominally compensated to operate

with a 2-pF parasitic load. Higher parasitic capacitive loads without an $R_{(ISO)}$ are allowed as the signal gain increases (increasing the unloaded phase margin). If a long trace is required, and the 6-dB signal loss intrinsic to a doubly-terminated transmission line is acceptable, implement a matched-impedance transmission line using microstrip or stripline techniques (consult an ECL design handbook for microstrip and stripline layout techniques). A 50- Ω environment is normally not necessary onboard, and in fact a higher-impedance environment improves distortion as shown in the distortion-versus-load plots. With a characteristic board-trace impedance definition based on board material and trace dimensions, a matching series resistor in the trace from the output of the SN1050x is used as well as a terminating shunt resistor at the input of the destination device. Remember also that the terminating impedance is the parallel combination of the shunt resistor and the input impedance of the destination device: this total effective impedance should be set to match the trace impedance. If the 6-dB attenuation of a doubly terminated transmission line is unacceptable, a long trace can be series-terminated at the source end only. Treat the trace as a capacitive load in this case and add an $R_{(ISO)}$ resistor in series with the output to isolate any capacitance to the amplifier. This setting does not preserve the signal integrity of a doubly-terminated line. If the input impedance of the destination device is low, the signal is attenuated due to the voltage divider formed by the series output into the terminating impedance.

5. **Socketing a high speed part like the SN1050x is not recommended.** The additional lead length and pin-to-pin capacitance introduced by the socket can create a troublesome parasitic network which can make it almost impossible to achieve a smooth, stable frequency response. Best results are obtained by soldering the SN1050x onto the board.

THERMAL ANALYSIS

The SN1050x family of devices does not incorporate automatic thermal shutoff protection, so the designer must take care to ensure that the design does not violate the absolute-maximum junction temperature of the device. Failure may result if the absolute-maximum junction temperature of 150°C is exceeded.

The thermal characteristics of the device are dictated by the package and the PC board. Maximum power dissipation for a given package can be calculated using the following formula.

$$P_{Dmax} = \frac{T_{max} - T_A}{\theta_{JA}}$$

where:

P_{Dmax} is the maximum power dissipation in the amplifier (W).

T_{max} is the absolute maximum junction temperature (°C).

T_A is the ambient temperature (°C).

$\theta_{JA} = \theta_{JC} + \theta_{CA}$

θ_{JC} is the thermal coefficient from the silicon junctions to the case (°C/W).

θ_{CA} is the thermal coefficient from the case to ambient air (°C/W).

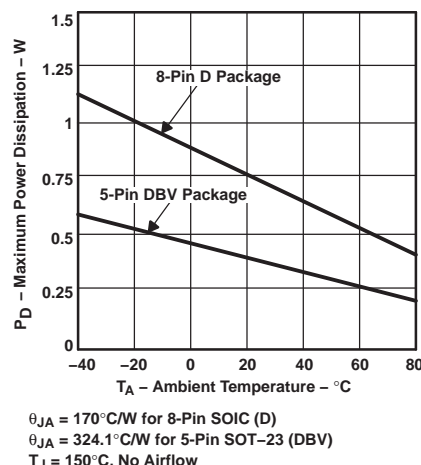

Figure 46. Maximum Power Dissipation vs Ambient Temperature

When determining whether or not the device satisfies the maximum power dissipation requirement, it is important to consider not only quiescent power dissipation, but also dynamic power dissipation. Often maximum power dissipation is difficult to quantify because the signal pattern is inconsistent, but an estimate of the RMS power dissipation can provide visibility into a possible problem.

PACKAGING INFORMATION

Orderable Device	Status ⁽¹⁾	Package Type	Package Drawing	Pins	Package Qty	Eco Plan ⁽²⁾	Lead/ Ball Finish	MSL Peak Temp ⁽³⁾	Samples (Requires Login)
SN10501D	ACTIVE	SOIC	D	8	75	Green (RoHS & no Sb/Br)	CU NIPDAU	Level-1-260C-UNLIM	
SN10501DBVR	ACTIVE	SOT-23	DBV	5	3000	Green (RoHS & no Sb/Br)	CU NIPDAU	Level-1-260C-UNLIM	
SN10501DBVRG4	ACTIVE	SOT-23	DBV	5	3000	Green (RoHS & no Sb/Br)	CU NIPDAU	Level-1-260C-UNLIM	
SN10501DBVT	ACTIVE	SOT-23	DBV	5	250	Green (RoHS & no Sb/Br)	CU NIPDAU	Level-1-260C-UNLIM	
SN10501DBVTG4	ACTIVE	SOT-23	DBV	5	250	Green (RoHS & no Sb/Br)	CU NIPDAU	Level-1-260C-UNLIM	
SN10501DG4	ACTIVE	SOIC	D	8	75	Green (RoHS & no Sb/Br)	CU NIPDAU	Level-1-260C-UNLIM	
SN10501DGK	ACTIVE	VSSOP	DGK	8	80	Green (RoHS & no Sb/Br)	CU NIPDAU	Level-1-260C-UNLIM	
SN10501DGKG4	ACTIVE	VSSOP	DGK	8	80	Green (RoHS & no Sb/Br)	CU NIPDAU	Level-1-260C-UNLIM	
SN10501DGN	ACTIVE	MSOP- PowerPAD	DGN	8	80	Green (RoHS & no Sb/Br)	CU NIPDAU	Level-1-260C-UNLIM	
SN10501DGNG4	ACTIVE	MSOP- PowerPAD	DGN	8	80	Green (RoHS & no Sb/Br)	CU NIPDAU	Level-1-260C-UNLIM	
SN10501DR	ACTIVE	SOIC	D	8	2500	Green (RoHS & no Sb/Br)	CU NIPDAU	Level-1-260C-UNLIM	
SN10501DRG4	ACTIVE	SOIC	D	8	2500	Green (RoHS & no Sb/Br)	CU NIPDAU	Level-1-260C-UNLIM	
SN10502D	ACTIVE	SOIC	D	8	75	Green (RoHS & no Sb/Br)	CU NIPDAU	Level-1-260C-UNLIM	
SN10502DG4	ACTIVE	SOIC	D	8	75	Green (RoHS & no Sb/Br)	CU NIPDAU	Level-1-260C-UNLIM	
SN10502DGK	ACTIVE	VSSOP	DGK	8	80	Green (RoHS & no Sb/Br)	CU NIPDAU	Level-1-260C-UNLIM	
SN10502DGKG4	ACTIVE	VSSOP	DGK	8	80	Green (RoHS & no Sb/Br)	CU NIPDAU	Level-1-260C-UNLIM	
SN10502DGKR	ACTIVE	VSSOP	DGK	8	2500	Green (RoHS & no Sb/Br)	CU NIPDAU	Level-1-260C-UNLIM	

Orderable Device	Status ⁽¹⁾	Package Type	Package Drawing	Pins	Package Qty	Eco Plan ⁽²⁾	Lead/ Ball Finish	MSL Peak Temp ⁽³⁾	Samples (Requires Login)
SN10502DGKRG4	ACTIVE	VSSOP	DGK	8	2500	Green (RoHS & no Sb/Br)	CU NIPDAU	Level-1-260C-UNLIM	
SN10502DGN	ACTIVE	MSOP- PowerPAD	DGN	8	80	Green (RoHS & no Sb/Br)	CU NIPDAU	Level-1-260C-UNLIM	
SN10502DGNG4	ACTIVE	MSOP- PowerPAD	DGN	8	80	Green (RoHS & no Sb/Br)	CU NIPDAU	Level-1-260C-UNLIM	
SN10502DGNR	ACTIVE	MSOP- PowerPAD	DGN	8		TBD	Call TI	Call TI	
SN10502DGNRG4	ACTIVE	MSOP- PowerPAD	DGN	8		TBD	Call TI	Call TI	
SN10502DR	ACTIVE	SOIC	D	8	2500	Green (RoHS & no Sb/Br)	CU NIPDAU	Level-1-260C-UNLIM	
SN10502DRG4	ACTIVE	SOIC	D	8	2500	Green (RoHS & no Sb/Br)	CU NIPDAU	Level-1-260C-UNLIM	
SN10503D	ACTIVE	SOIC	D	14	50	Green (RoHS & no Sb/Br)	CU NIPDAU	Level-1-260C-UNLIM	
SN10503DG4	ACTIVE	SOIC	D	14	50	Green (RoHS & no Sb/Br)	CU NIPDAU	Level-1-260C-UNLIM	
SN10503DR	ACTIVE	SOIC	D	14	2500	Green (RoHS & no Sb/Br)	CU NIPDAU	Level-1-260C-UNLIM	
SN10503DRG4	ACTIVE	SOIC	D	14	2500	Green (RoHS & no Sb/Br)	CU NIPDAU	Level-1-260C-UNLIM	
SN10503PWP	ACTIVE	HTSSOP	PWP	14	90	Green (RoHS & no Sb/Br)	CU NIPDAU	Level-2-260C-1 YEAR	
SN10503PWPG4	ACTIVE	HTSSOP	PWP	14	90	Green (RoHS & no Sb/Br)	CU NIPDAU	Level-2-260C-1 YEAR	

⁽¹⁾ The marketing status values are defined as follows:

ACTIVE: Product device recommended for new designs.

LIFEBUY: TI has announced that the device will be discontinued, and a lifetime-buy period is in effect.

NRND: Not recommended for new designs. Device is in production to support existing customers, but TI does not recommend using this part in a new design.

PREVIEW: Device has been announced but is not in production. Samples may or may not be available.

OBsolete: TI has discontinued the production of the device.

⁽²⁾ Eco Plan - The planned eco-friendly classification: Pb-Free (RoHS), Pb-Free (RoHS Exempt), or Green (RoHS & no Sb/Br) - please check <http://www.ti.com/productcontent> for the latest availability information and additional product content details.

TBD: The Pb-Free/Green conversion plan has not been defined.

Pb-Free (RoHS): TI's terms "Lead-Free" or "Pb-Free" mean semiconductor products that are compatible with the current RoHS requirements for all 6 substances, including the requirement that lead not exceed 0.1% by weight in homogeneous materials. Where designed to be soldered at high temperatures, TI Pb-Free products are suitable for use in specified lead-free processes.

Pb-Free (RoHS Exempt): This component has a RoHS exemption for either 1) lead-based flip-chip solder bumps used between the die and package, or 2) lead-based die adhesive used between the die and leadframe. The component is otherwise considered Pb-Free (RoHS compatible) as defined above.

Green (RoHS & no Sb/Br): TI defines "Green" to mean Pb-Free (RoHS compatible), and free of Bromine (Br) and Antimony (Sb) based flame retardants (Br or Sb do not exceed 0.1% by weight in homogeneous material)

⁽³⁾ MSL, Peak Temp. -- The Moisture Sensitivity Level rating according to the JEDEC industry standard classifications, and peak solder temperature.

Important Information and Disclaimer: The information provided on this page represents TI's knowledge and belief as of the date that it is provided. TI bases its knowledge and belief on information provided by third parties, and makes no representation or warranty as to the accuracy of such information. Efforts are underway to better integrate information from third parties. TI has taken and continues to take reasonable steps to provide representative and accurate information but may not have conducted destructive testing or chemical analysis on incoming materials and chemicals. TI and TI suppliers consider certain information to be proprietary, and thus CAS numbers and other limited information may not be available for release.

In no event shall TI's liability arising out of such information exceed the total purchase price of the TI part(s) at issue in this document sold by TI to Customer on an annual basis.

TAPE AND REEL INFORMATION
REEL DIMENSIONS

TAPE DIMENSIONS

A0	Dimension designed to accommodate the component width
B0	Dimension designed to accommodate the component length
K0	Dimension designed to accommodate the component thickness
W	Overall width of the carrier tape
P1	Pitch between successive cavity centers

TAPE AND REEL INFORMATION

*All dimensions are nominal

Device	Package Type	Package Drawing	Pins	SPQ	Reel Diameter (mm)	Reel Width W1 (mm)	A0 (mm)	B0 (mm)	K0 (mm)	P1 (mm)	W (mm)	Pin1 Quadrant
SN10501DBVR	SOT-23	DBV	5	3000	180.0	9.0	3.15	3.2	1.4	4.0	8.0	Q3
SN10501DBVT	SOT-23	DBV	5	250	180.0	9.0	3.15	3.2	1.4	4.0	8.0	Q3
SN10501DR	SOIC	D	8	2500	330.0	12.4	6.4	5.2	2.1	8.0	12.0	Q1
SN10502DGKR	VSSOP	DGK	8	2500	330.0	12.4	5.3	3.4	1.4	8.0	12.0	Q1
SN10502DR	SOIC	D	8	2500	330.0	12.4	6.4	5.2	2.1	8.0	12.0	Q1
SN10503DR	SOIC	D	14	2500	330.0	16.4	6.5	9.0	2.1	8.0	16.0	Q1

TAPE AND REEL BOX DIMENSIONS

*All dimensions are nominal

Device	Package Type	Package Drawing	Pins	SPQ	Length (mm)	Width (mm)	Height (mm)
SN10501DBVR	SOT-23	DBV	5	3000	182.0	182.0	20.0
SN10501DBVT	SOT-23	DBV	5	250	182.0	182.0	20.0
SN10501DR	SOIC	D	8	2500	367.0	367.0	35.0
SN10502DGKR	VSSOP	DGK	8	2500	358.0	335.0	35.0
SN10502DR	SOIC	D	8	2500	367.0	367.0	35.0
SN10503DR	SOIC	D	14	2500	367.0	367.0	38.0

DBV (R-PDSO-G5)

PLASTIC SMALL-OUTLINE PACKAGE

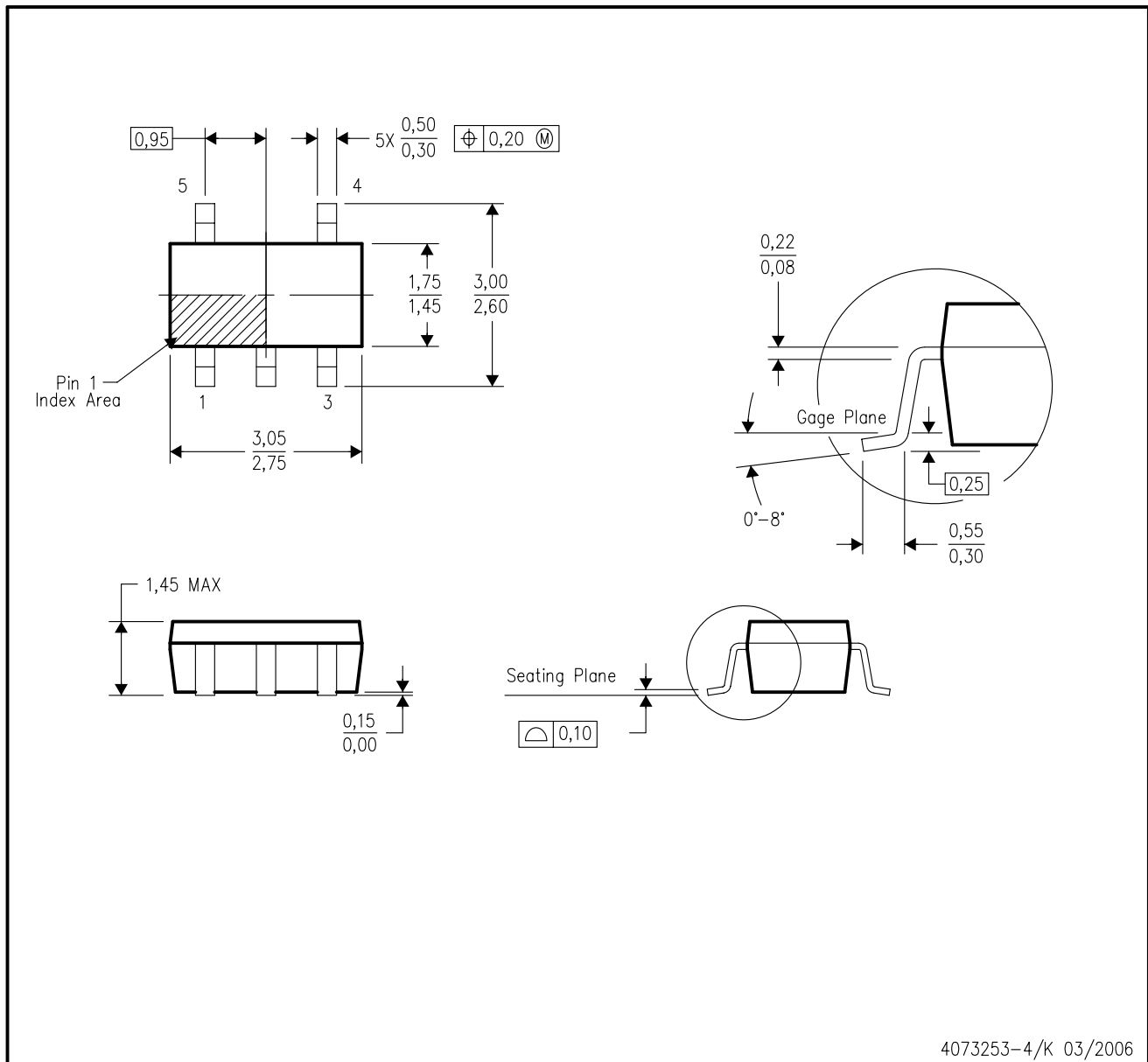

- NOTES:
- A. All linear dimensions are in millimeters.
 - B. This drawing is subject to change without notice.
 - C. Body dimensions do not include mold flash or protrusion. Mold flash and protrusion shall not exceed 0.15 per side.
 - D. Falls within JEDEC MO-178 Variation AA.

DBV (R-PDSO-G5)

PLASTIC SMALL OUTLINE



- NOTES:
- A. All linear dimensions are in millimeters.
 - B. This drawing is subject to change without notice.
 - C. Customers should place a note on the circuit board fabrication drawing not to alter the center solder mask defined pad.
 - D. Publication IPC-7351 is recommended for alternate designs.
 - E. Laser cutting apertures with trapezoidal walls and also rounding corners will offer better paste release. Customers should contact their board assembly site for stencil design recommendations. Example stencil design based on a 50% volumetric metal load solder paste. Refer to IPC-7525 for other stencil recommendations.

DGN (S-PDSO-G8)

PowerPAD™ PLASTIC SMALL OUTLINE

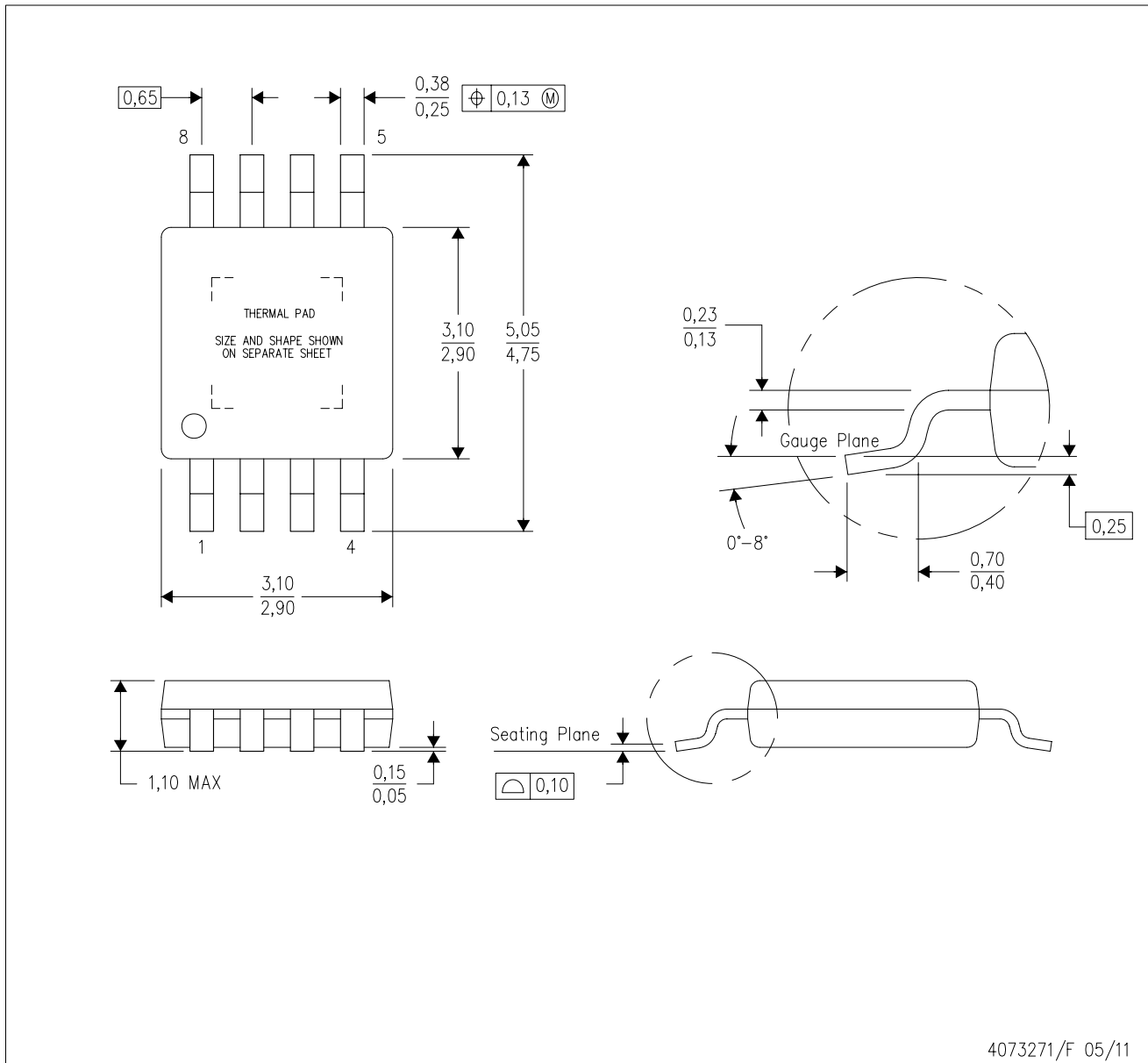

- NOTES:
- All linear dimensions are in millimeters.
 - This drawing is subject to change without notice.
 - Body dimensions do not include mold flash or protrusion.
 - This package is designed to be soldered to a thermal pad on the board. Refer to Technical Brief, PowerPad Thermally Enhanced Package, Texas Instruments Literature No. SLMA002 for information regarding recommended board layout. This document is available at www.ti.com <<http://www.ti.com>>.
 - See the additional figure in the Product Data Sheet for details regarding the exposed thermal pad features and dimensions.
 - Falls within JEDEC MO-187 variation AA-T

PowerPAD is a trademark of Texas Instruments.

PWP (R-PDSO-G14)

PowerPAD™ PLASTIC SMALL OUTLINE

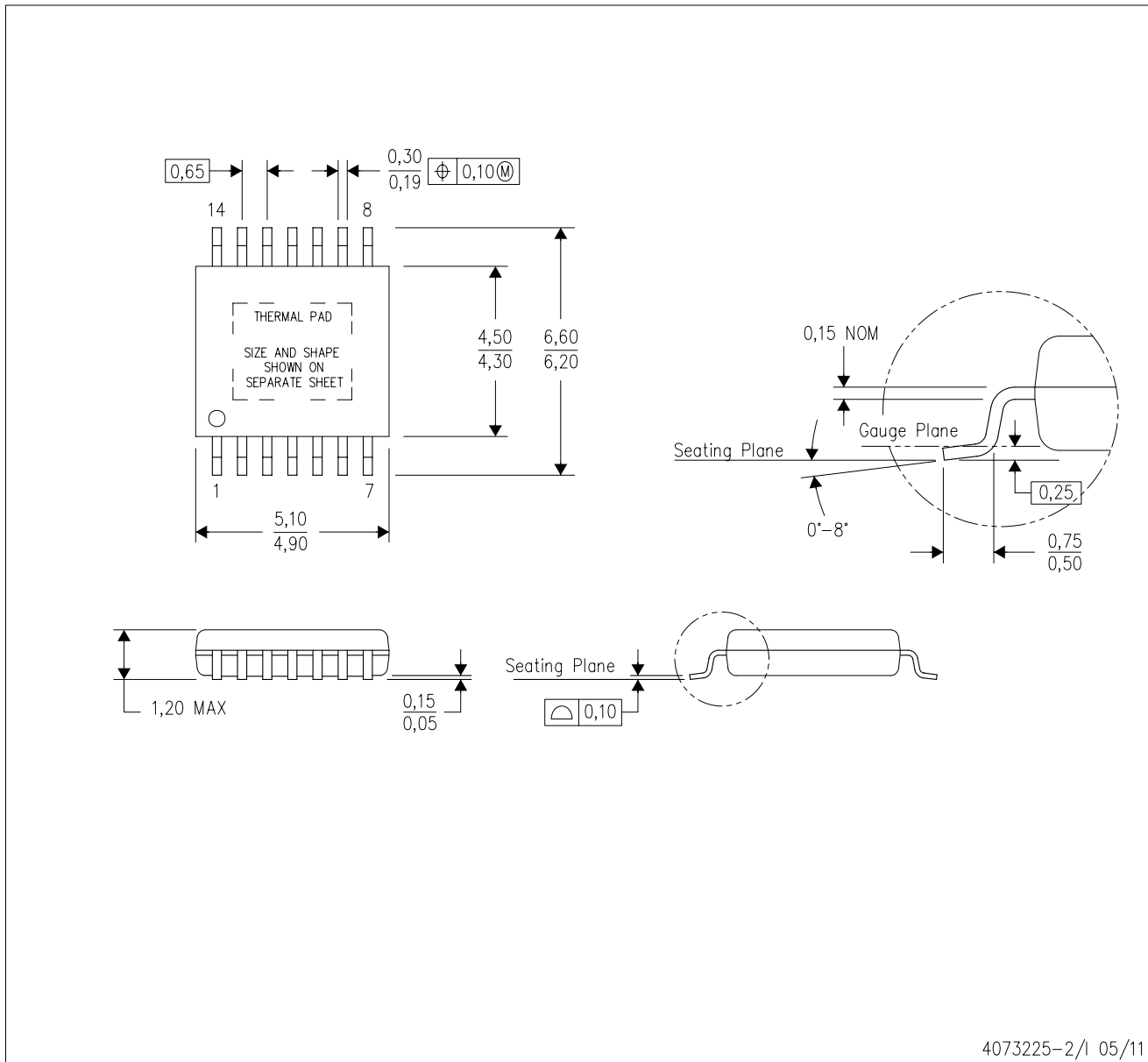

4073225-2/1 05/11

- NOTES:
- All linear dimensions are in millimeters.
 - This drawing is subject to change without notice.
 - Body dimensions do not include mold flash or protrusions. Mold flash and protrusion shall not exceed 0.15 per side.
 - This package is designed to be soldered to a thermal pad on the board. Refer to Technical Brief, PowerPad Thermally Enhanced Package, Texas Instruments Literature No. SLMA002 for information regarding recommended board layout. This document is available at www.ti.com <<http://www.ti.com>>.
 - See the additional figure in the Product Data Sheet for details regarding the exposed thermal pad features and dimensions.
 - Falls within JEDEC MO-153

PowerPAD is a trademark of Texas Instruments.

D (R-PDSO-G8)

PLASTIC SMALL OUTLINE

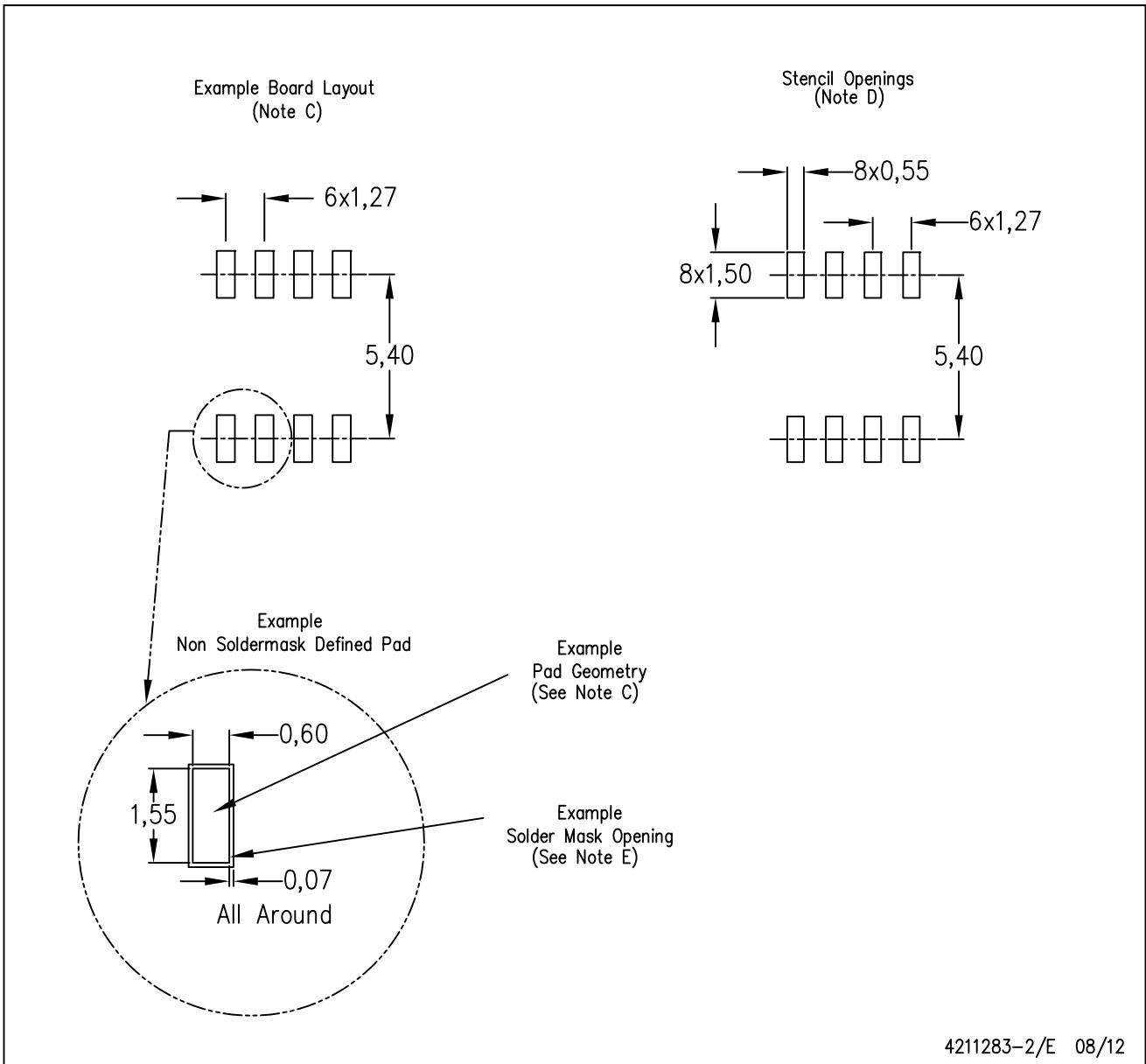

- NOTES:
- A. All linear dimensions are in millimeters.
 - B. This drawing is subject to change without notice.
 - C. Publication IPC-7351 is recommended for alternate designs.
 - D. Laser cutting apertures with trapezoidal walls and also rounding corners will offer better paste release. Customers should contact their board assembly site for stencil design recommendations. Refer to IPC-7525 for other stencil recommendations.
 - E. Customers should contact their board fabrication site for solder mask tolerances between and around signal pads.

IMPORTANT NOTICE

Texas Instruments Incorporated and its subsidiaries (TI) reserve the right to make corrections, enhancements, improvements and other changes to its semiconductor products and services per JESD46, latest issue, and to discontinue any product or service per JESD48, latest issue. Buyers should obtain the latest relevant information before placing orders and should verify that such information is current and complete. All semiconductor products (also referred to herein as "components") are sold subject to TI's terms and conditions of sale supplied at the time of order acknowledgment.

TI warrants performance of its components to the specifications applicable at the time of sale, in accordance with the warranty in TI's terms and conditions of sale of semiconductor products. Testing and other quality control techniques are used to the extent TI deems necessary to support this warranty. Except where mandated by applicable law, testing of all parameters of each component is not necessarily performed.

TI assumes no liability for applications assistance or the design of Buyers' products. Buyers are responsible for their products and applications using TI components. To minimize the risks associated with Buyers' products and applications, Buyers should provide adequate design and operating safeguards.

TI does not warrant or represent that any license, either express or implied, is granted under any patent right, copyright, mask work right, or other intellectual property right relating to any combination, machine, or process in which TI components or services are used. Information published by TI regarding third-party products or services does not constitute a license to use such products or services or a warranty or endorsement thereof. Use of such information may require a license from a third party under the patents or other intellectual property of the third party, or a license from TI under the patents or other intellectual property of TI.

Reproduction of significant portions of TI information in TI data books or data sheets is permissible only if reproduction is without alteration and is accompanied by all associated warranties, conditions, limitations, and notices. TI is not responsible or liable for such altered documentation. Information of third parties may be subject to additional restrictions.

Resale of TI components or services with statements different from or beyond the parameters stated by TI for that component or service voids all express and any implied warranties for the associated TI component or service and is an unfair and deceptive business practice. TI is not responsible or liable for any such statements.

Buyer acknowledges and agrees that it is solely responsible for compliance with all legal, regulatory and safety-related requirements concerning its products, and any use of TI components in its applications, notwithstanding any applications-related information or support that may be provided by TI. Buyer represents and agrees that it has all the necessary expertise to create and implement safeguards which anticipate dangerous consequences of failures, monitor failures and their consequences, lessen the likelihood of failures that might cause harm and take appropriate remedial actions. Buyer will fully indemnify TI and its representatives against any damages arising out of the use of any TI components in safety-critical applications.

In some cases, TI components may be promoted specifically to facilitate safety-related applications. With such components, TI's goal is to help enable customers to design and create their own end-product solutions that meet applicable functional safety standards and requirements. Nonetheless, such components are subject to these terms.

No TI components are authorized for use in FDA Class III (or similar life-critical medical equipment) unless authorized officers of the parties have executed a special agreement specifically governing such use.

Only those TI components which TI has specifically designated as military grade or "enhanced plastic" are designed and intended for use in military/aerospace applications or environments. Buyer acknowledges and agrees that any military or aerospace use of TI components which have **not** been so designated is solely at the Buyer's risk, and that Buyer is solely responsible for compliance with all legal and regulatory requirements in connection with such use.

TI has specifically designated certain components which meet ISO/TS16949 requirements, mainly for automotive use. Components which have not been so designated are neither designed nor intended for automotive use; and TI will not be responsible for any failure of such components to meet such requirements.

Products

Audio	www.ti.com/audio
Amplifiers	amplifier.ti.com
Data Converters	dataconverter.ti.com
DLP® Products	www.dlp.com
DSP	dsp.ti.com
Clocks and Timers	www.ti.com/clocks
Interface	interface.ti.com
Logic	logic.ti.com
Power Mgmt	power.ti.com
Microcontrollers	microcontroller.ti.com
RFID	www.ti-rfid.com
OMAP Applications Processors	www.ti.com/omap
Wireless Connectivity	www.ti.com/wirelessconnectivity

Applications

Automotive and Transportation	www.ti.com/automotive
Communications and Telecom	www.ti.com/communications
Computers and Peripherals	www.ti.com/computers
Consumer Electronics	www.ti.com/consumer-apps
Energy and Lighting	www.ti.com/energy
Industrial	www.ti.com/industrial
Medical	www.ti.com/medical
Security	www.ti.com/security
Space, Avionics and Defense	www.ti.com/space-avionics-defense
Video and Imaging	www.ti.com/video

TI E2E Community

e2e.ti.com