

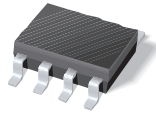
Distributed by:

**JAMECO**<sup>®</sup>  
ELECTRONICS

**www.Jameco.com ♦ 1-800-831-4242**

The content and copyrights of the attached  
material are the property of its owner.

Jameco Part Number 1372640



## 3.3-V CAN TRANSCEIVERS

### FEATURES

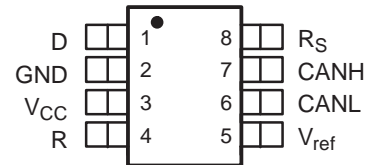
- Operates With a 3.3-V Supply
- Low Power Replacement for the PCA82C250 Footprint
- Bus/Pin ESD Protection Exceeds 16 kV HBM
- High Input Impedance Allows for 120 Nodes on a Bus
- Controlled Driver Output Transition Times for Improved Signal Quality on the SN65HVD230 and SN65HVD231
- Unpowered Node Does Not Disturb the Bus
- Compatible With the Requirements of the ISO 11898 Standard
- Low-Current SN65HVD230 Standby Mode 370  $\mu$ A Typical
- Low-Current SN65HVD231 Sleep Mode 40 nA Typical
- Designed for Signaling Rates<sup>(1)</sup> up to 1 Megabit/Second (Mbps)
- Thermal Shutdown Protection
- Open-Circuit Fail-Safe Design
- Glitch-Free Power-Up and Power-Down Protection for Hot-Plugging Applications

<sup>(1)</sup> The signaling rate of a line is the number of voltage transitions that are made per second expressed in the units bps (bits per second).

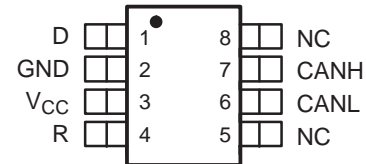
### APPLICATIONS

- Motor Control
- Industrial Automation
- Basestation Control and Status
- Robotics
- Automotive
- UPS Control

SN65HVD230D (Marked as VP230)  
SN65HVD231D (Marked as VP231)  
(TOP VIEW)

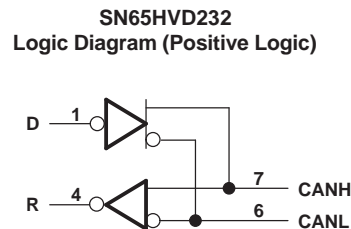
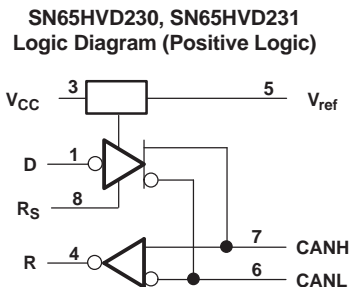


SN65HVD232D (Marked as VP232)  
(TOP VIEW)



NC – No internal connection

### LOGIC DIAGRAM (POSITIVE LOGIC)



Please be aware that an important notice concerning availability, standard warranty, and use in critical applications of Texas Instruments semiconductor products and disclaimers thereto appears at the end of this data sheet.

TMS320Lx240x is a trademark of Texas Instruments.



These devices have limited built-in ESD protection. The leads should be shorted together or the device placed in conductive foam during storage or handling to prevent electrostatic damage to the MOS gates.

## DESCRIPTION

The SN65HVD230, SN65HVD231, and SN65HVD232 controller area network (CAN) transceivers are designed for use with the Texas Instruments TMS320Lx240x™; 3.3-V DSPs with CAN controllers, or with equivalent devices. They are intended for use in applications employing the CAN serial communication physical layer in accordance with the ISO 11898 standard. Each CAN transceiver is designed to provide differential transmit capability to the bus and differential receive capability to a CAN controller at speeds up to 1 Mbps.

Designed for operation in especially-harsh environments, these devices feature cross-wire protection, loss-of-ground and overvoltage protection, overtemperature protection, as well as wide common-mode range.

The transceiver interfaces the single-ended CAN controller with the differential CAN bus found in industrial, building automation, and automotive applications. It operates over a -2-V to 7-V common-mode range on the bus, and it can withstand common-mode transients of  $\pm 25$  V.

On the SN65HVD230 and SN65HVD231, pin 8 provides three different modes of operation: high-speed, slope control, and low-power modes. The high-speed mode of operation is selected by connecting pin 8 to ground, allowing the transmitter output transistors to switch on and off as fast as possible with no limitation on the rise and fall slopes. The rise and fall slopes can be adjusted by connecting a resistor to ground at pin 8, since the slope is proportional to the pin's output current. This slope control is implemented with external resistor values of 10 k $\Omega$ , to achieve a 15-V/ $\mu$ s slew rate, to 100 k $\Omega$ , to achieve a 2-V/ $\mu$ s slew rate. See the *Application Information* section of this data sheet.

The circuit of the SN65HVD230 enters a low-current standby mode during which the driver is switched off and the receiver remains active if a high logic level is applied to pin 8. The DSP controller reverses this low-current standby mode when a dominant state (bus differential voltage > 900 mV typical) occurs on the bus.

The unique difference between the SN65HVD230 and the SN65HVD231 is that both the driver and the receiver are switched off in the SN65HVD231 when a high logic level is applied to pin 8 and remain in this sleep mode until the circuit is reactivated by a low logic level on pin 8.

The  $V_{ref}$  pin 5 on the SN65HVD230 and SN65HVD231 is available as a  $V_{CC}/2$  voltage reference.

The SN65HVD232 is a basic CAN transceiver with no added options; pins 5 and 8 are NC, no connection.

### AVAILABLE OPTIONS<sup>(1)</sup>

PART NUMBER	LOW POWER MODE	INTEGRATED SLOPE CONTROL	$V_{ref}$ PIN	$T_A$	MARKED AS:
SN65HVD230	Standby mode	Yes	Yes	40°C to 85°C	VP230
SN65HVD231	Sleep mode	Yes	Yes		VP231
SN65HVD232	No standby or sleep mode	No	No		VP232

(1) For the most current package and ordering information, see the Package Option Addendum at the end of this document, or see the TI web site at [www.ti.com](http://www.ti.com).

## FUNCTION TABLES

DRIVER (SN65HVD230, SN65HVD231) <sup>(1)</sup>				
INPUT D	$R_S$	OUTPUTS		BUS STATE
		CANH	CANL	
L	$V_{(R_S)} < 1.2$ V	H	L	Dominant
H		Z	Z	Recessive
Open	X	Z	Z	Recessive
X	$V_{(R_S)} > 0.75$ $V_{CC}$	Z	Z	Recessive

(1) H = high level; L = low level; X = irrelevant; ? = indeterminate; Z = high impedance

DRIVER (SN65HVD232) <sup>(1)</sup>			
INPUT D	OUTPUTS		BUS STATE
	CANH	CANL	
L	H	L	Dominant
H	Z	Z	Recessive
Open	Z	Z	Recessive

(1) H = high level; L = low level; Z = high impedance

RECEIVER (SN65HVD230) <sup>(1)</sup>		
DIFFERENTIAL INPUTS	R <sub>S</sub>	OUTPUT R
$V_{ID} \geq 0.9\text{ V}$	X	L
$0.5\text{ V} < V_{ID} < 0.9\text{ V}$	X	?
$V_{ID} \leq 0.5\text{ V}$	X	H
Open	X	H

(1) H = high level; L = low level; X = irrelevant; ? = indeterminate

RECEIVER (SN65HVD231) <sup>(1)</sup>		
DIFFERENTIAL INPUTS	R <sub>S</sub>	OUTPUT R
$V_{ID} \geq 0.9\text{ V}$	$V_{(RS)} < 1.2\text{ V}$	L
$0.5\text{ V} < V_{ID} < 0.9\text{ V}$		?
$V_{ID} \leq 0.5\text{ V}$		H
X	$V_{(RS)} > 0.75\text{ V}_{CC}$	H
X	$1.2\text{ V} < V_{(RS)} < 0.75\text{ V}_{CC}$	?
Open	X	H

(1) H = high level; L = low level; X = irrelevant; ? = indeterminate

RECEIVER (SN65HVD232) <sup>(1)</sup>	
DIFFERENTIAL INPUTS	OUTPUT R
$V_{ID} \geq 0.9\text{ V}$	L
$0.5\text{ V} < V_{ID} < 0.9\text{ V}$	?
$V_{ID} \leq 0.5\text{ V}$	H
Open	H

(1) H = high level; L = low level; X = irrelevant; ? = indeterminate

TRANSCIVER MODES (SN65HVD230, SN65HVD231)	
V <sub>(RS)</sub>	OPERATING MODE
$V_{(RS)} > 0.75\text{ V}_{CC}$	Standby
10 k $\Omega$ to 100 k $\Omega$ to ground	Slope control
$V_{(RS)} < 1\text{ V}$	High speed (no slope control)

## TERMINAL FUNCTIONS

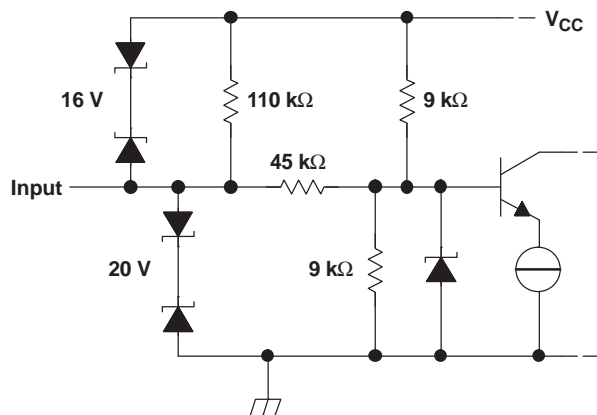
TERMINAL		DESCRIPTION
NAME	NO.	
<b>SN65HVD230, SN65HVD231</b>		
CANL	6	Low bus output
CANH	7	High bus output
D	1	Driver input
GND	2	Ground
R	4	Receiver output

**TERMINAL FUNCTIONS (continued)**

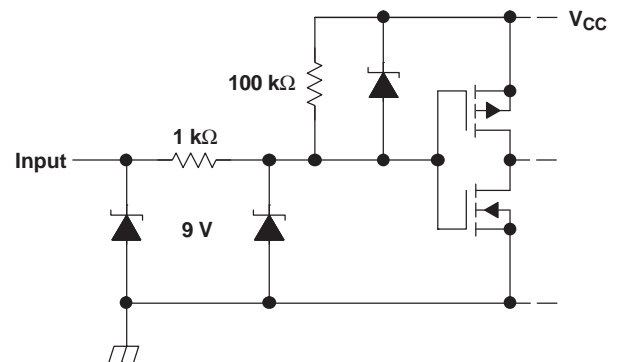
TERMINAL		DESCRIPTION
NAME	NO.	
R <sub>S</sub>	8	Standby/slope control
V <sub>CC</sub>	3	Supply voltage
V <sub>ref</sub>	5	Reference output
<b>SN65HVD232</b>		
CANL	6	Low bus output
CANH	7	High bus output
D	1	Driver input
GND	2	Ground
NC	5, 8	No connection
R	4	Receiver output
V <sub>CC</sub>	3	Supply voltage

**EQUIVALENT INPUT AND OUTPUT SCHEMATIC DIAGRAMS**

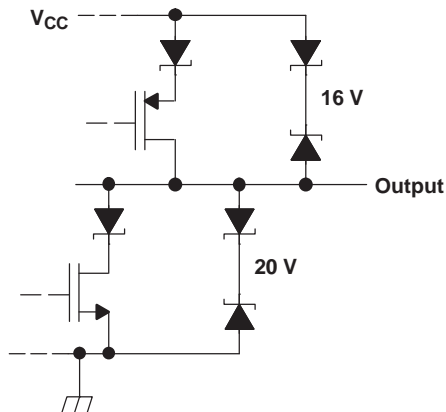
CANH and CANL Inputs



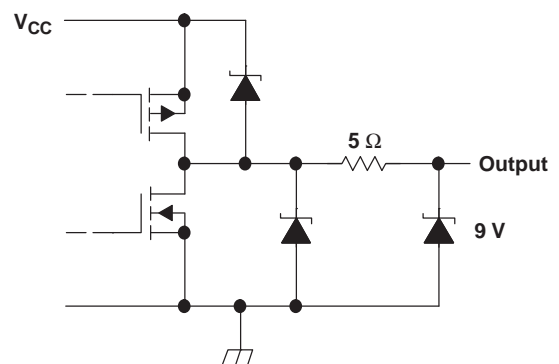
D Input



CANH and CANL Outputs



R Output



## ABSOLUTE MAXIMUM RATINGS

over operating free-air temperature range (unless otherwise noted)<sup>(1)(2)</sup>

			UNIT
Supply voltage range, $V_{CC}$			-0.3 V to 6 V
Voltage range at any bus terminal (CANH or CANL)			-4 V to 16 V
Voltage input range, transient pulse, CANH and CANL, through 100 $\Omega$ (see <a href="#">Figure 7</a> )			-25 V to 25 V
Input voltage range, $V_I$ (D or R)			-0.5 V to $V_{CC} + 0.5$ V
Receiver output current, $I_O$			$\pm 11$ mA
Electrostatic discharge	Human body model <sup>(3)</sup>	CANH, CANL and GND	16 kV
		All Pins	4 kV
	Charged-device model <sup>(4)</sup>	All pins	1 kV
Continuous total power dissipation			See Dissipation Rating Table

- (1) Stresses beyond those listed under "absolute maximum ratings" may cause permanent damage to the device. These are stress ratings only, and functional operation of the device at these or any other conditions beyond those indicated under "recommended operating conditions" is not implied. Exposure to absolute-maximum-rated conditions for extended periods may affect device reliability.
- (2) All voltage values, except differential I/O bus voltages, are with respect to network ground terminal.
- (3) Tested in accordance with JEDEC Standard 22, Test Method A114-A.
- (4) Tested in accordance with JEDEC Standard 22, Test Method C101.

## DISSIPATION RATING TABLE

PACKAGE	$T_A \leq 25^\circ\text{C}$ POWER RATING	DERATING FACTOR <sup>(1)</sup> ABOVE $T_A = 25^\circ\text{C}$	$T_A = 70^\circ\text{C}$ POWER RATING	$T_A = 85^\circ\text{C}$ POWER RATING
D	725 mW	5.8 mW/ $^\circ\text{C}$	464 mW	377 mW

- (1) This is the inverse of the junction-to-ambient thermal resistance when board-mounted and with no air flow.

## RECOMMENDED OPERATING CONDITIONS

		MIN	NOM	MAX	UNIT
Supply voltage, $V_{CC}$		3		3.6	V
Voltage at any bus terminal (common mode) $V_{IC}$		-2 <sup>(1)</sup>		7	V
Voltage at any bus terminal (separately) $V_I$		-2.5		7.5	V
High-level input voltage, $V_{IH}$	D, R	2			V
Low-level input voltage, $V_{IL}$	D, R			0.8	V
Differential input voltage, $V_{ID}$ (see <a href="#">Figure 5</a> )		-6		6	V
Input voltage, $V_{(RS)}$		0		$V_{CC}$	V
Input voltage for standby or sleep, $V_{(RS)}$		0.75 $V_{CC}$		$V_{CC}$	V
Wave-shaping resistance, $R_s$		0		100	k $\Omega$
High-level output current, $I_{OH}$	Driver	-40			mA
	Receiver	-8			
Low-level output current, $I_{OL}$	Driver			48	mA
	Receiver			8	
Operating free-air temperature, $T_A$		-40		85	$^\circ\text{C}$

- (1) The algebraic convention, in which the least positive (most negative) limit is designated as minimum is used in this data sheet.

## DRIVER ELECTRICAL CHARACTERISTICS

over recommended operating conditions (unless otherwise noted)

PARAMETER		TEST CONDITIONS		MIN	TYP <sup>(1)</sup>	MAX	UNIT		
V <sub>OH</sub>	Bus output voltage	Dominant	V <sub>I</sub> = 0 V, See Figure 1 and Figure 3	CANH	2.45	V <sub>CC</sub>	V		
				CANL	0.5	1.25			
V <sub>OL</sub>	Bus output voltage	Recessive	V <sub>I</sub> = 3 V, See Figure 1 and Figure 3	CANH	2.3				
				CANL	2.3				
V <sub>OD(D)</sub>	Differential output voltage	Dominant	V <sub>I</sub> = 0 V, See Figure 1	1.5	2	3	V		
			V <sub>I</sub> = 0 V, See Figure 2	1.2	2	3			
V <sub>OD(R)</sub>	Differential output voltage	Recessive	V <sub>I</sub> = 3 V, See Figure 1	-120	0	12	mV		
			V <sub>I</sub> = 3 V, No load	-0.5	-0.2	0.05	V		
I <sub>IH</sub>	High-level input current	V <sub>I</sub> = 2 V		-30			μA		
I <sub>IL</sub>	Low-level input current	V <sub>I</sub> = 0.8 V		-30			μA		
I <sub>OS</sub>	Short-circuit output current	V <sub>CANH</sub> = -2 V		-250		250	mA		
		V <sub>CANL</sub> = 7 V		-250		250			
C <sub>o</sub>	Output capacitance	See receiver							
I <sub>CC</sub>	Supply current	Standby	SN65HVD230	V <sub>(RS)</sub> = V <sub>CC</sub>		370	600	μA	
		Sleep	SN65HVD231	V <sub>(RS)</sub> = V <sub>CC</sub> , D at V <sub>CC</sub>		0.04	1		
		All devices	Dominant	V <sub>I</sub> = 0 V, No load	Dominant		10	17	mA
			Recessive	V <sub>I</sub> = V <sub>CC</sub> , No load	Recessive		10	17	

(1) All typical values are at 25°C and with a 3.3-V supply.

## DRIVER SWITCHING CHARACTERISTICS

over recommended operating conditions (unless otherwise noted)

PARAMETER		TEST CONDITIONS	MIN	TYP	MAX	UNIT	
<b>SN65HVD230 AND SN65HVD231</b>							
t <sub>PLH</sub>	Propagation delay time, low-to-high-level output	V <sub>(RS)</sub> = 0 V		35	85	ns	
		R <sub>S</sub> with 10 kΩ to ground		70	125		
		R <sub>S</sub> with 100 kΩ to ground		500	870		
t <sub>PHL</sub>	Propagation delay time, high-to-low-level output	V <sub>(RS)</sub> = 0 V		70	120	ns	
		R <sub>S</sub> with 10 kΩ to ground		130	180		
		R <sub>S</sub> with 100 kΩ to ground		870	1200		
t <sub>sk(p)</sub>	Pulse skew ( t <sub>PHL</sub> - t <sub>PLH</sub>  )	V <sub>(RS)</sub> = 0 V		35		ns	
		R <sub>S</sub> with 10 kΩ to ground	C <sub>L</sub> = 50 pF, See Figure 4	60			
		R <sub>S</sub> with 100 kΩ to ground		370			
t <sub>r</sub>	Differential output signal rise time	V <sub>(RS)</sub> = 0 V	25	50	100	ns	
t <sub>f</sub>	Differential output signal fall time		40	55	80	ns	
t <sub>r</sub>	Differential output signal rise time	R <sub>S</sub> with 10 kΩ to ground	80	120	160	ns	
t <sub>f</sub>	Differential output signal fall time		80	125	150	ns	
t <sub>r</sub>	Differential output signal rise time	R <sub>S</sub> with 100 kΩ to ground	600	800	1200	ns	
t <sub>f</sub>	Differential output signal fall time		600	825	1000	ns	
<b>SN65HVD232</b>							
t <sub>PLH</sub>	Propagation delay time, low-to-high-level output	C <sub>L</sub> = 50 pF, See Figure 4		35	85	ns	
t <sub>PHL</sub>	Propagation delay time, high-to-low-level output			70	120		
t <sub>sk(p)</sub>	Pulse skew ( t <sub>PHL</sub> - t <sub>PLH</sub>  )			35			
t <sub>r</sub>	Differential output signal rise time			25	50		100
t <sub>f</sub>	Differential output signal fall time			40	55		80

## RECEIVER ELECTRICAL CHARACTERISTICS

over recommended operating conditions (unless otherwise noted)

PARAMETER		TEST CONDITIONS	MIN	TYP <sup>(1)</sup>	MAX	UNIT	
$V_{IT+}$	Positive-going input threshold voltage	See <a href="#">Table 1</a>		750	900	mV	
$V_{IT-}$	Negative-going input threshold voltage			500	650	mV	
$V_{HYS}$	Hysteresis voltage ( $V_{IT+} - V_{IT-}$ )			100			
$V_{OH}$	High-level output voltage	$-6\text{ V} \leq V_{ID} \leq 500\text{ mV}$ , $I_O = -8\text{ mA}$ , See <a href="#">Figure 5</a>	2.4			V	
$V_{OL}$	Low-level output voltage	$900\text{ mV} \leq V_{ID} \leq 6\text{ V}$ , $I_O = 8\text{ mA}$ , See <a href="#">Figure 5</a>			0.4		
$I_I$	Bus input current	$V_{IH} = 7\text{ V}$	Other input at 0 V, D = 3 V		100	250	$\mu\text{A}$
		$V_{IH} = 7\text{ V}$ , $V_{CC} = 0\text{ V}$			100	350	
		$V_{IH} = -2\text{ V}$			-200	-30	$\mu\text{A}$
		$V_{IH} = -2\text{ V}$ , $V_{CC} = 0\text{ V}$			-100	-20	
$C_i$	CANH, CANL input capacitance	Pin-to-ground, $V_I = 0.4 \sin(4E6\pi t) + 0.5\text{ V}$ $V_{(D)} = 3\text{ V}$ ,		32		pF	
$C_{diff}$	Differential input capacitance	Pin-to-pin, $V_I = 0.4 \sin(4E6\pi t) + 0.5\text{ V}$ $V_{(D)} = 3\text{ V}$ ,		16		pF	
$R_{diff}$	Differential input resistance	Pin-to-pin, $V_{(D)} = 3\text{ V}$	40	70	100	k $\Omega$	
$R_I$	CANH, CANL input resistance		20	35	50	k $\Omega$	
$I_{CC}$	Supply current	See driver					

(1) All typical values are at 25°C and with a 3.3-V supply.

## RECEIVER SWITCHING CHARACTERISTICS

over recommended operating conditions (unless otherwise noted)

PARAMETER		TEST CONDITIONS	MIN	TYP	MAX	UNIT
$t_{PLH}$	Propagation delay time, low-to-high-level output	See <a href="#">Figure 6</a>		35	50	ns
$t_{PHL}$	Propagation delay time, high-to-low-level output			35	50	ns
$t_{sk(p)}$	Pulse skew ( $ t_{PHL} - t_{PLH} $ )				10	ns
$t_r$	Output signal rise time	See <a href="#">Figure 6</a>		1.5		ns
$t_f$	Output signal fall time			1.5		ns

## DEVICE SWITCHING CHARACTERISTICS

over recommended operating conditions (unless otherwise noted)

PARAMETER		TEST CONDITIONS	MIN	TYP	MAX	UNIT
$t_{(LOOP1)}$	Total loop delay, driver input to receiver output, recessive to dominant	$V_{(RS)} = 0\text{ V}$ , See <a href="#">Figure 9</a>		70	115	ns
		$R_S$ with 10 k $\Omega$ to ground, See <a href="#">Figure 9</a>		105	175	
		$R_S$ with 100 k $\Omega$ to ground, See <a href="#">Figure 9</a>		535	920	
$t_{(LOOP2)}$	Total loop delay, driver input to receiver output, dominant to recessive	$V_{(RS)} = 0\text{ V}$ , See <a href="#">Figure 9</a>		100	135	ns
		$R_S$ with 10 k $\Omega$ to ground, See <a href="#">Figure 9</a>		155	185	
		$R_S$ with 100 k $\Omega$ to ground, See <a href="#">Figure 9</a>		830	990	

## DEVICE CONTROL-PIN CHARACTERISTICS

over recommended operating conditions (unless otherwise noted)

PARAMETER		TEST CONDITIONS	MIN	TYP <sup>(1)</sup>	MAX	UNIT
$t_{(WAKE)}$	SN65HVD230 wake-up time from standby mode with $R_S$	See <a href="#">Figure 8</a>		0.55	1.5	$\mu\text{s}$
	SN65HVD231 wake-up time from sleep mode with $R_S$			3	5	$\mu\text{s}$

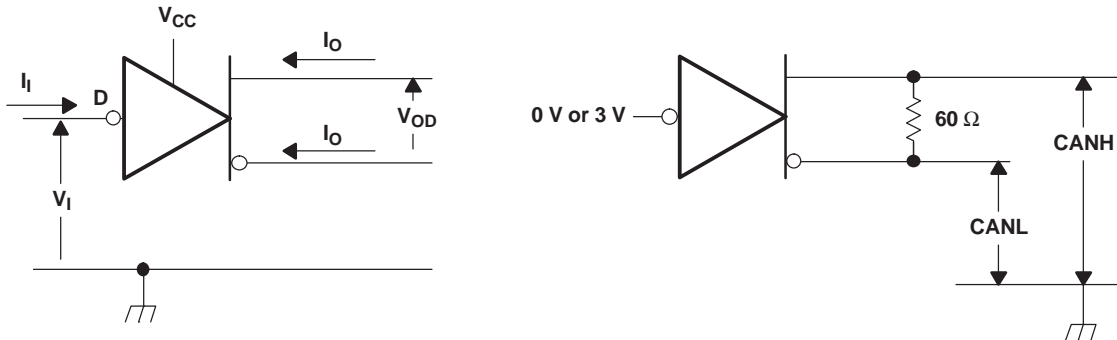
(1) All typical values are at 25°C and with a 3.3-V supply.

**DEVICE CONTROL-PIN CHARACTERISTICS (continued)**

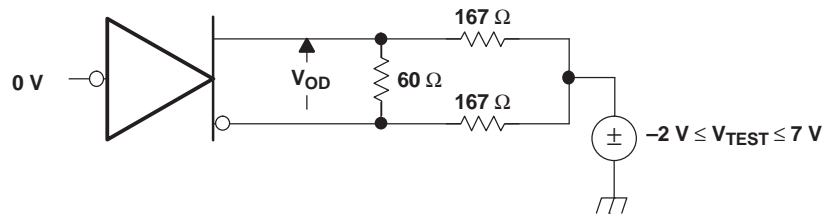
over recommended operating conditions (unless otherwise noted)

PARAMETER	TEST CONDITIONS	MIN	TYP <sup>(1)</sup>	MAX	UNIT
V <sub>ref</sub>	-5 μA < I <sub>(Vref)</sub> < 5 μA	0.45 V <sub>CC</sub>		0.55 V <sub>CC</sub>	V
	-50 μA < I <sub>(Vref)</sub> < 50 μA	0.4 V <sub>CC</sub>		0.6 V <sub>CC</sub>	
I <sub>(RS)</sub>	V <sub>(RS)</sub> < 1 V	-450		0	μA

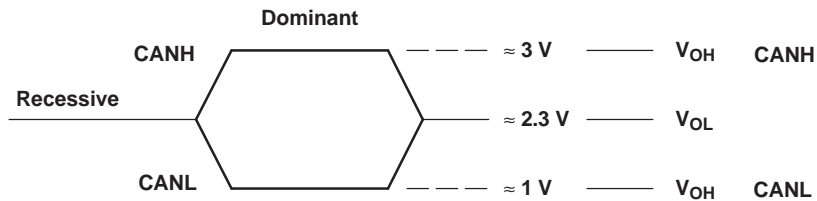
**PARAMETER MEASUREMENT INFORMATION**



**Figure 1. Driver Voltage and Current Definitions**

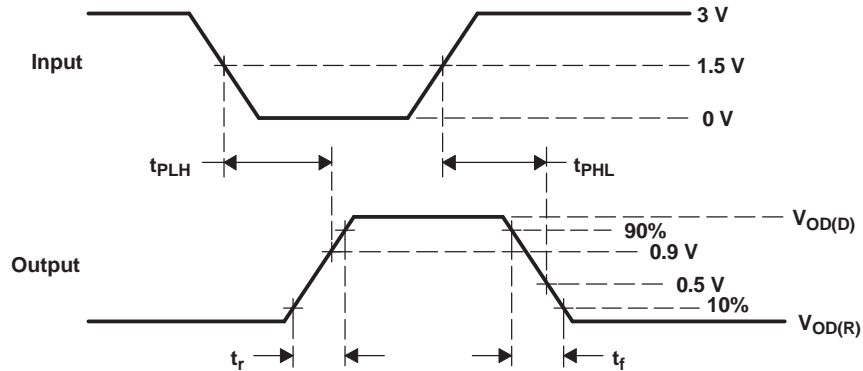
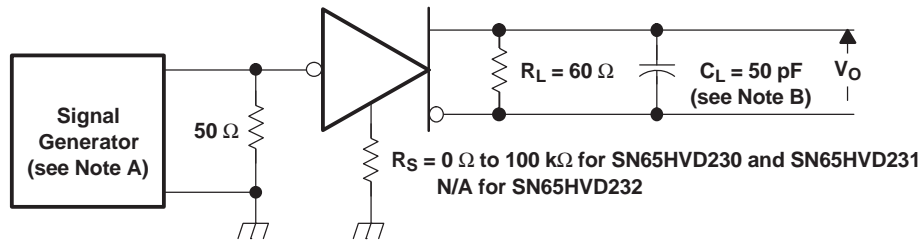


**Figure 2. Driver V<sub>OD</sub>**



**Figure 3. Driver Output Voltage Definitions**

PARAMETER MEASUREMENT INFORMATION (continued)



- A. The input pulse is supplied by a generator having the following characteristics:  $PRR \leq 500\ \text{kHz}$ , 50% duty cycle,  $t_r \leq 6\ \text{ns}$ ,  $t_f \leq 6\ \text{ns}$ ,  $Z_o = 50\ \Omega$ .
- B.  $C_L$  includes probe and jig capacitance.

Figure 4. Driver Test Circuit and Voltage Waveforms

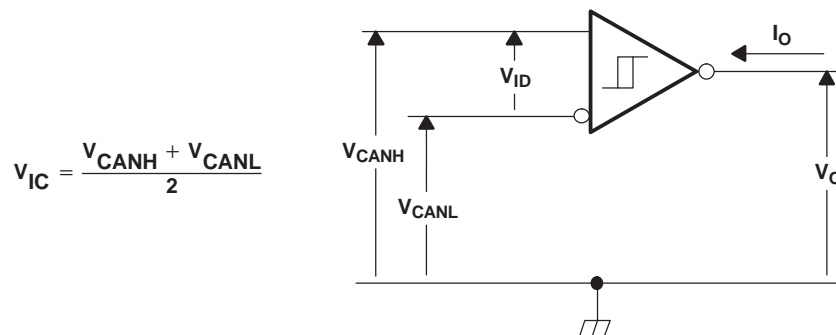
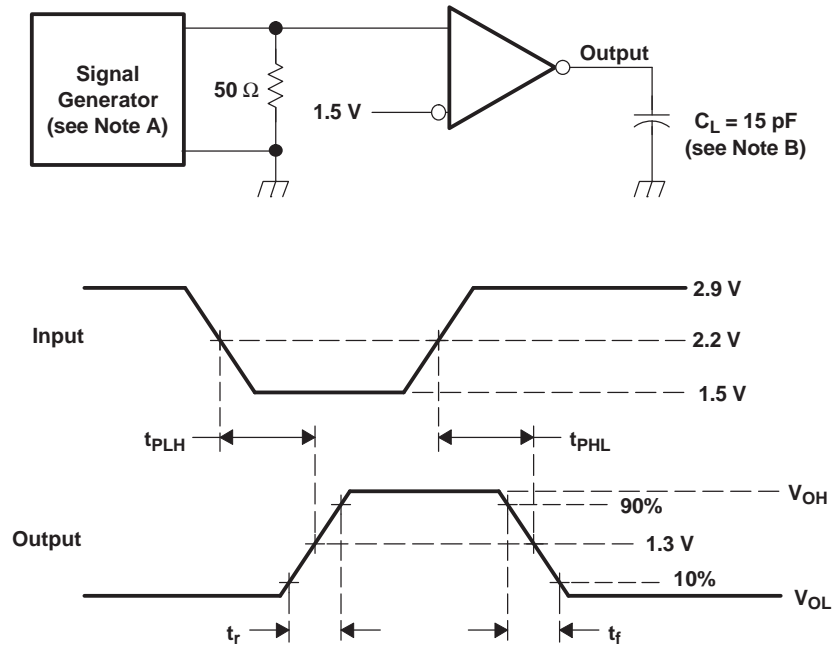


Figure 5. Receiver Voltage and Current Definitions

PARAMETER MEASUREMENT INFORMATION (continued)



- A. The input pulse is supplied by a generator having the following characteristics:  $\text{PRR} \leq 500 \text{ kHz}$ , 50% duty cycle,  $t_r \leq 6 \text{ ns}$ ,  $t_f \leq 6 \text{ ns}$ ,  $Z_o = 50 \Omega$ .
- B.  $C_L$  includes probe and jig capacitance.

Figure 6. Receiver Test Circuit and Voltage Waveforms

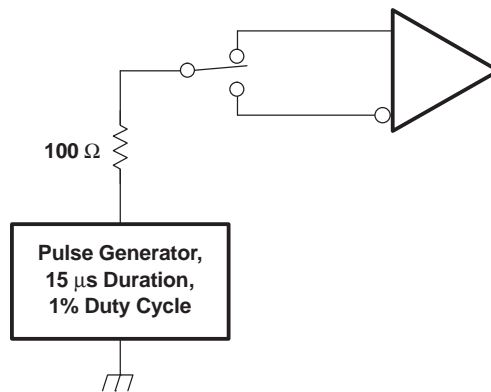


Figure 7. Overvoltage Protection

PARAMETER MEASUREMENT INFORMATION (continued)

Table 1. Receiver Characteristics Over Common Mode With  $V_{(Rs)} = 1.2\text{ V}$

$V_{IC}$	$V_{ID}$	$V_{CANH}$	$V_{CANL}$	R OUTPUT	
-2 V	900 mV	-1.55 V	-2.45 V	L	$V_{OL}$
7 V	900 mV	8.45 V	6.55 V	L	
1 V	6 V	4 V	-2 V	L	
4 V	6 V	7 V	1 V	L	
-2 V	500 mV	-1.75 V	-2.25 V	H	$V_{OH}$
7 V	500 mV	7.25 V	6.75 V	H	
1 V	-6 V	-2 V	4 V	H	
4 V	-6 V	1 V	7 V	H	
X	X	Open	Open	H	

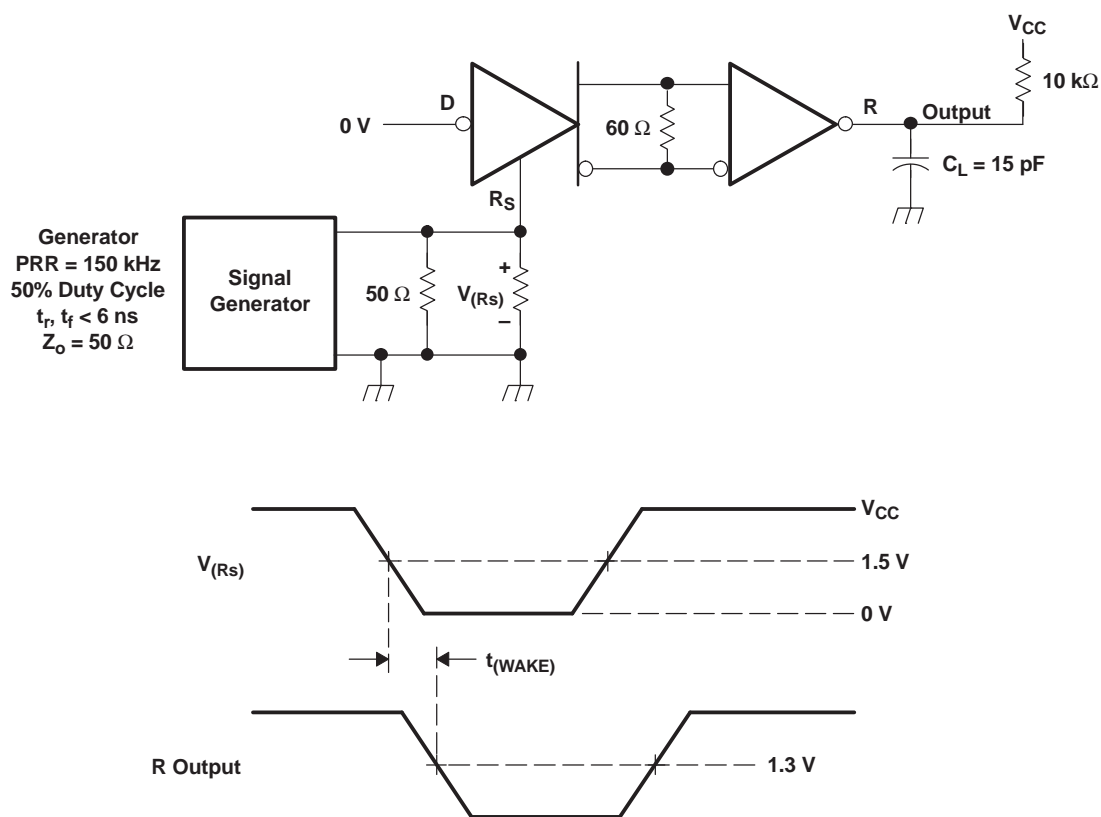
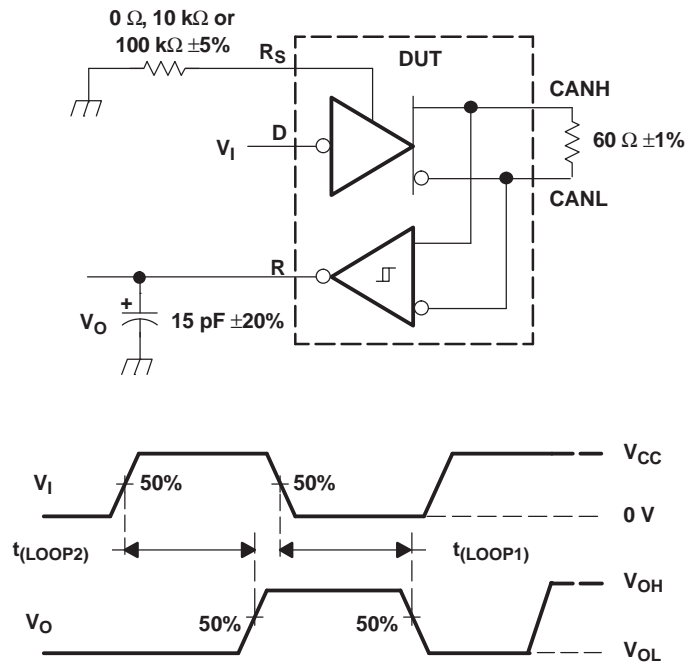


Figure 8.  $t_{(WAKE)}$  Test Circuit and Voltage Waveforms



- A. All  $V_1$  input pulses are supplied by a generator having the following characteristics:  $t_r$  or  $t_f \leq 6$  ns, Pulse Repetition Rate (PRR) = 125 kHz, 50% duty cycle.

Figure 9.  $t_{(LOOP)}$  Test Circuit and Voltage Waveforms

## TYPICAL CHARACTERISTICS

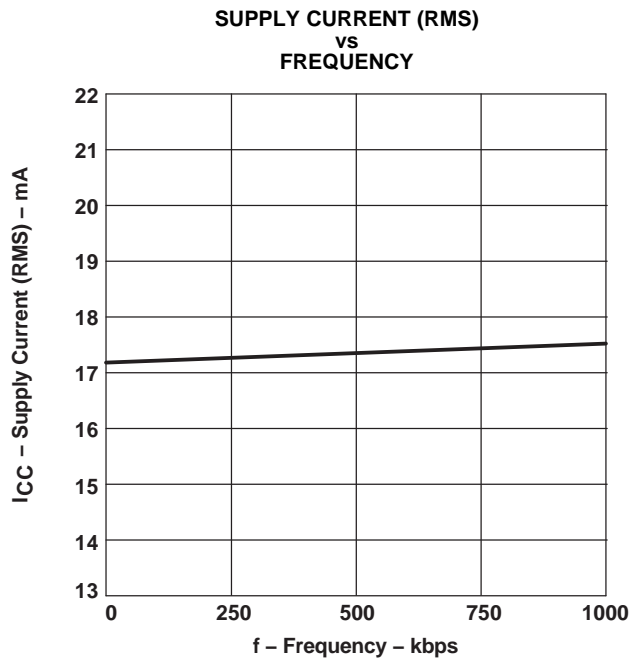


Figure 10.

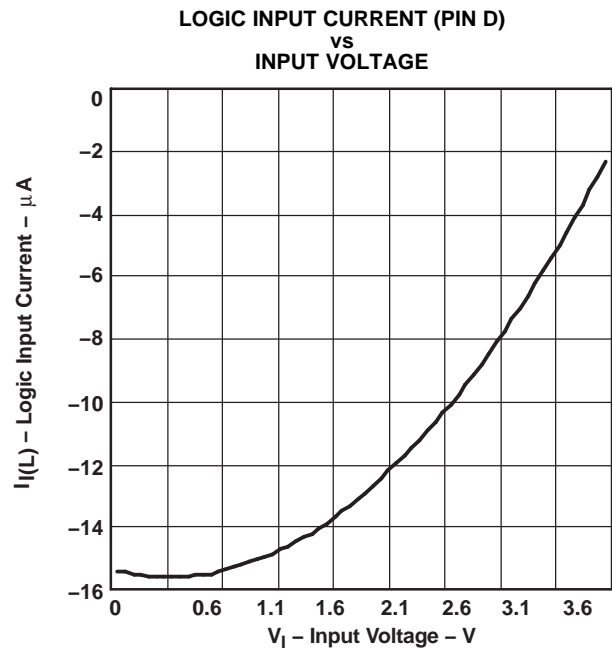


Figure 11.

**TYPICAL CHARACTERISTICS (continued)**

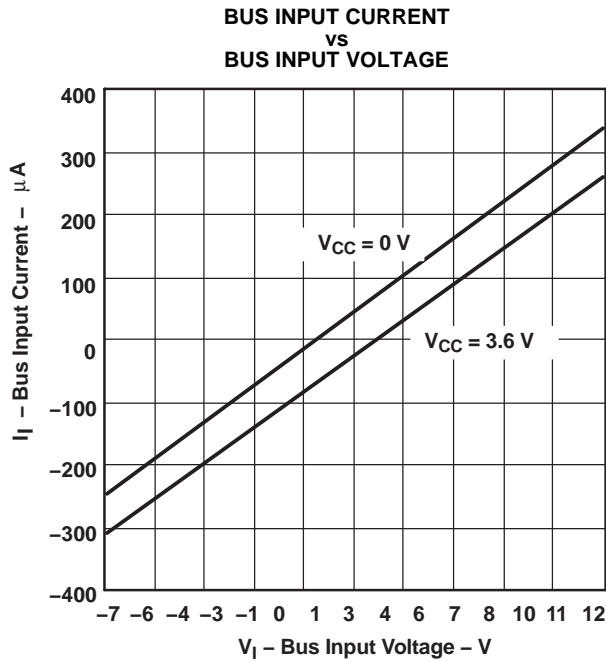


Figure 12.

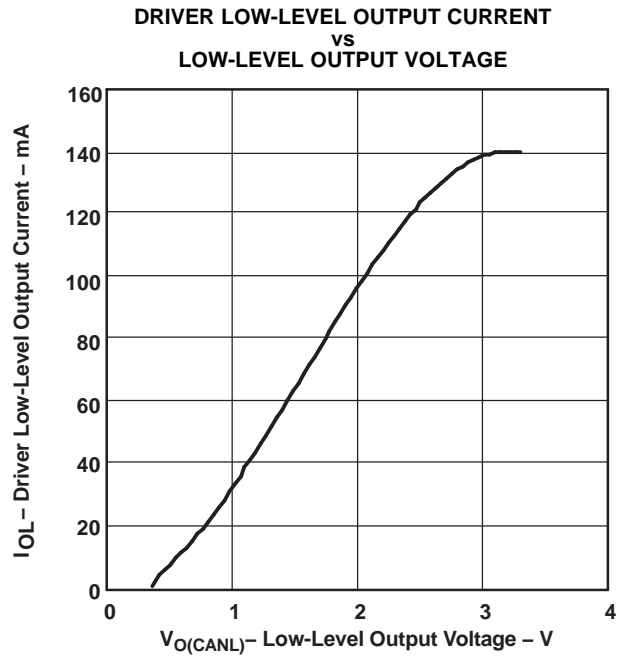


Figure 13.

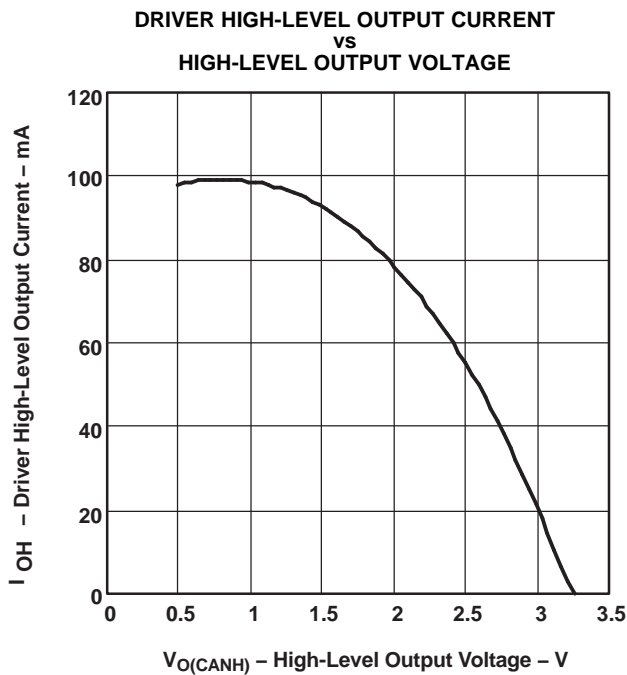


Figure 14.

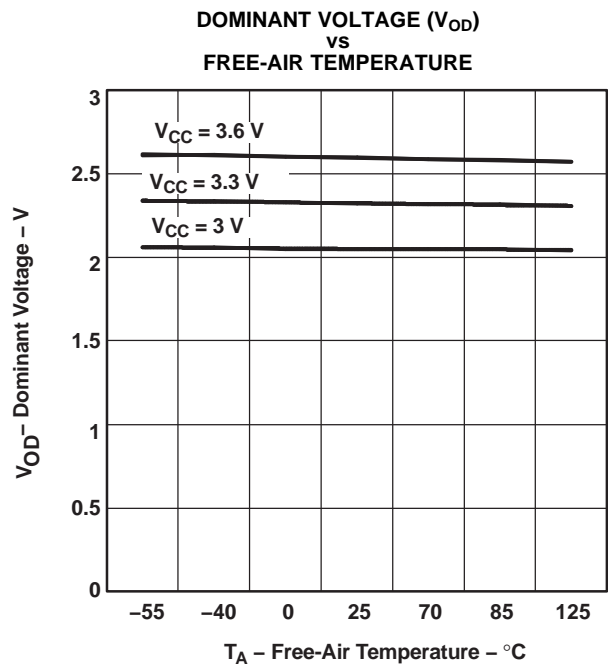


Figure 15.

TYPICAL CHARACTERISTICS (continued)

RECEIVER LOW-TO-HIGH PROPAGATION DELAY TIME  
 vs  
 FREE-AIR TEMPERATURE

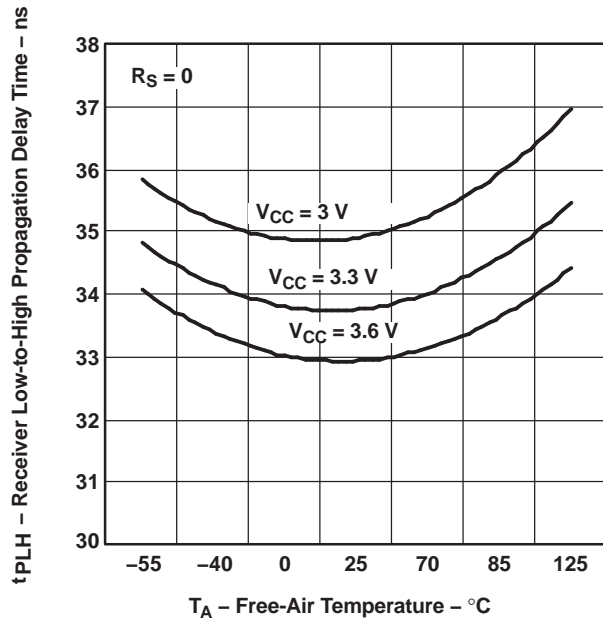


Figure 16.

RECEIVER HIGH-TO-LOW PROPAGATION DELAY TIME  
 vs  
 FREE-AIR TEMPERATURE

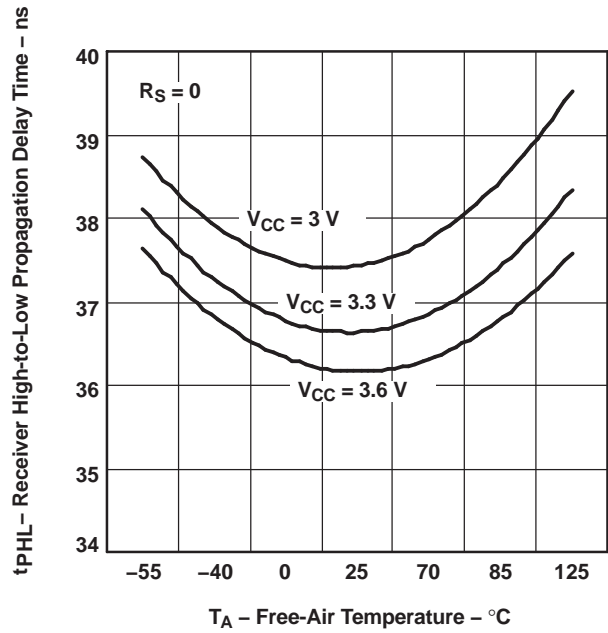


Figure 17.

DRIVER LOW-TO-HIGH PROPAGATION DELAY TIME  
 vs  
 FREE-AIR TEMPERATURE

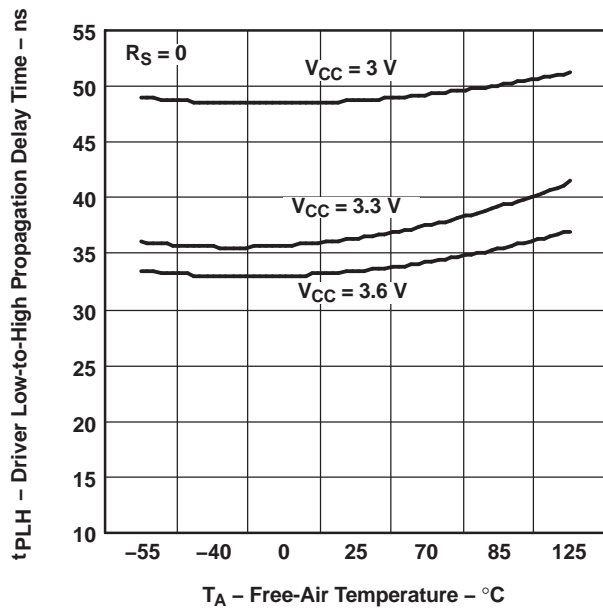


Figure 18.

DRIVER HIGH-TO-LOW PROPAGATION DELAY TIME  
 vs  
 FREE-AIR TEMPERATURE

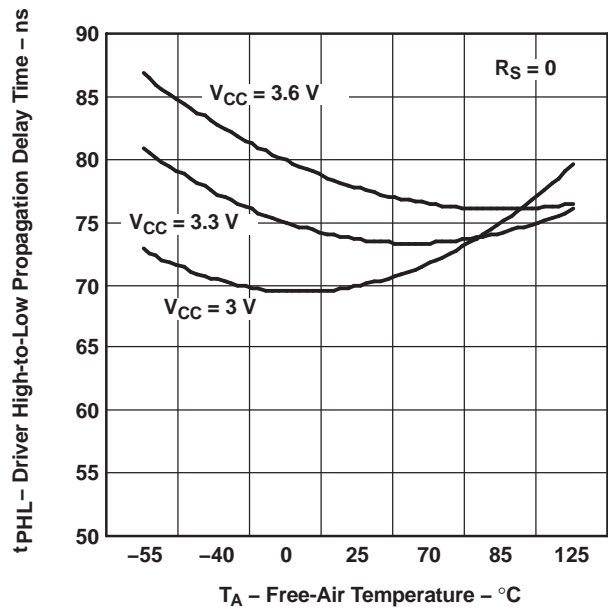


Figure 19.

**TYPICAL CHARACTERISTICS (continued)**

**DRIVER LOW-TO-HIGH PROPAGATION DELAY TIME  
vs  
FREE-AIR TEMPERATURE**

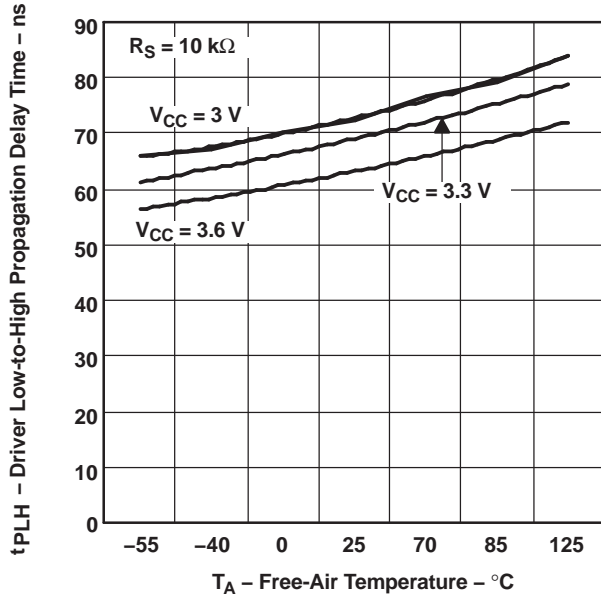


Figure 20.

**DRIVER HIGH-TO-LOW PROPAGATION DELAY TIME  
vs  
FREE-AIR TEMPERATURE**

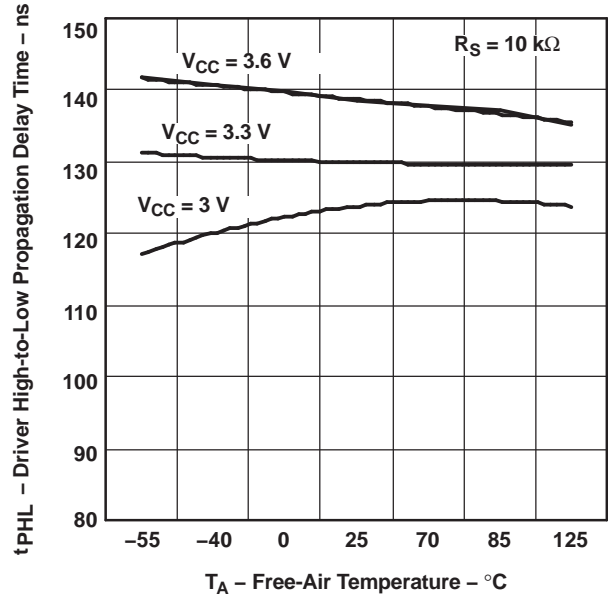


Figure 21.

**DRIVER LOW-TO-HIGH PROPAGATION DELAY TIME  
vs  
FREE-AIR TEMPERATURE**

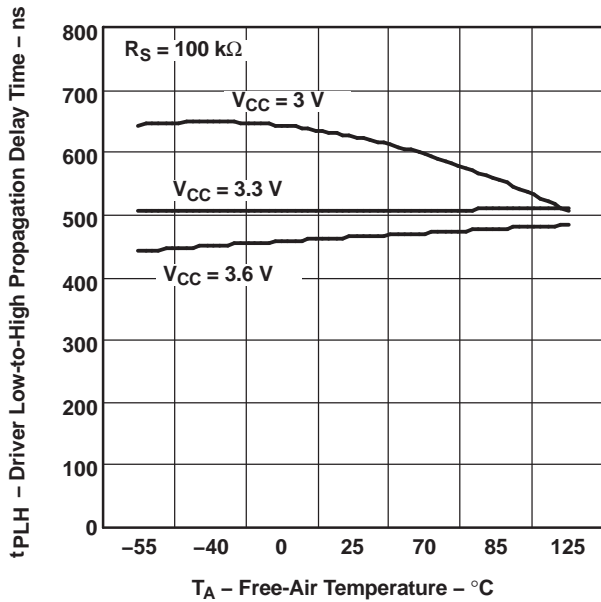


Figure 22.

**DRIVER HIGH-TO-LOW PROPAGATION DELAY TIME  
vs  
FREE-AIR TEMPERATURE**

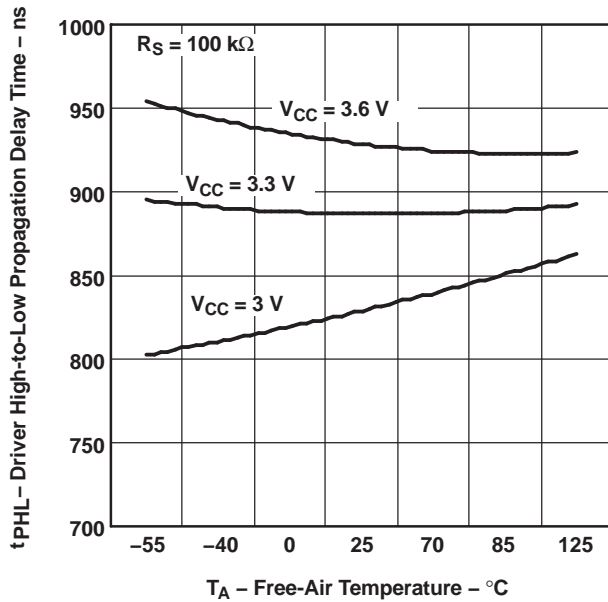


Figure 23.

TYPICAL CHARACTERISTICS (continued)

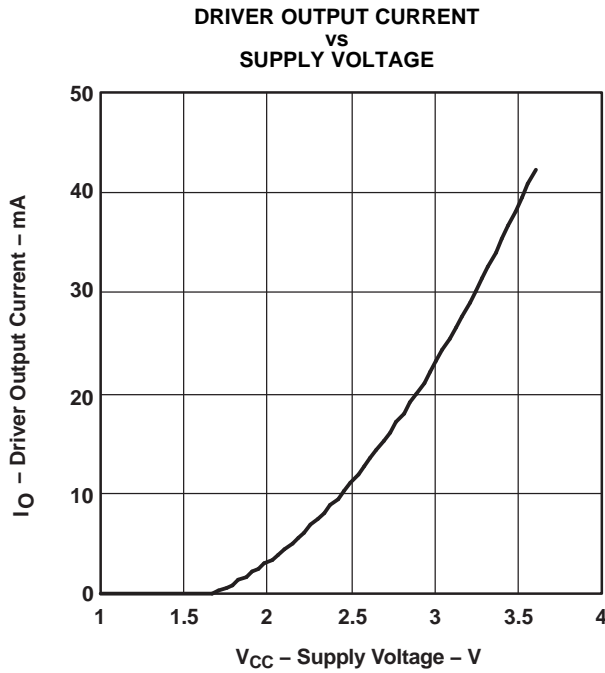


Figure 24.

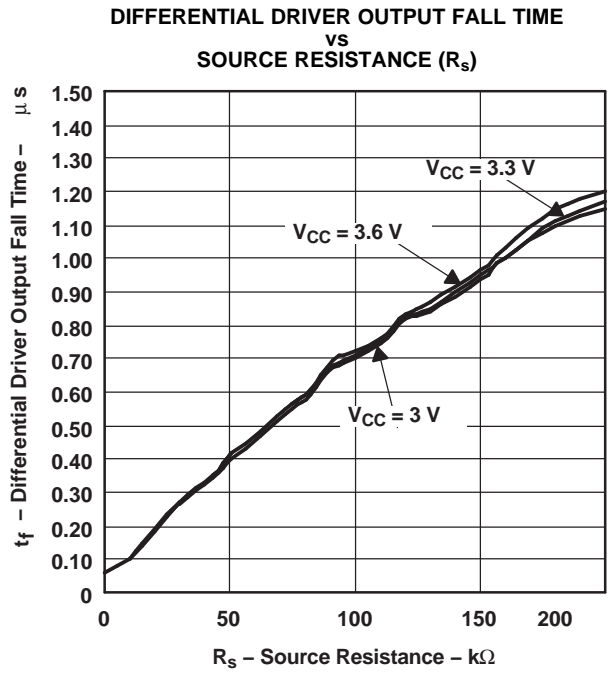


Figure 25.

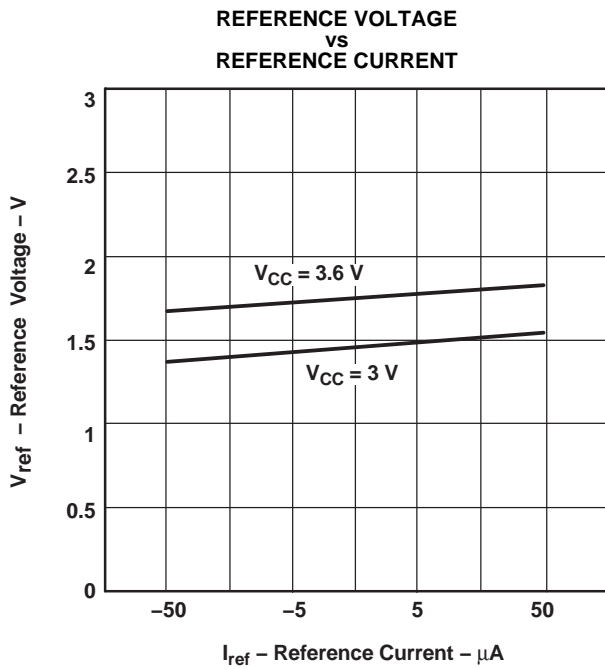


Figure 26.

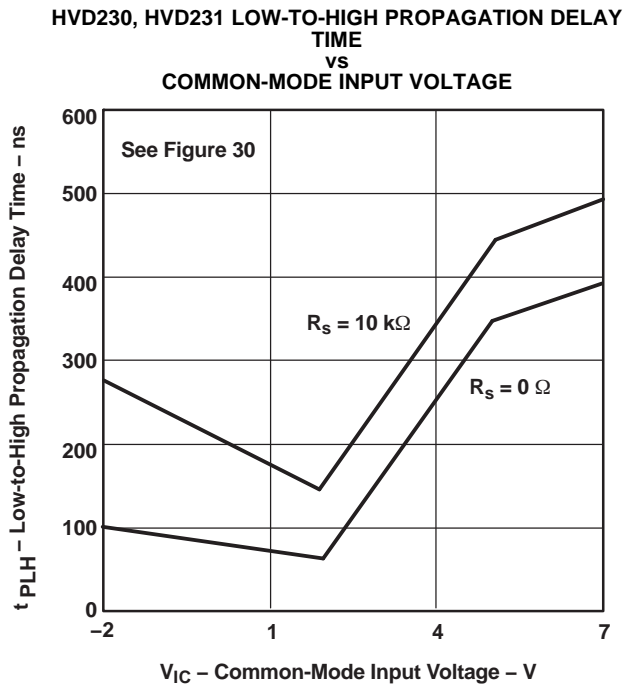


Figure 27.

**TYPICAL CHARACTERISTICS (continued)**

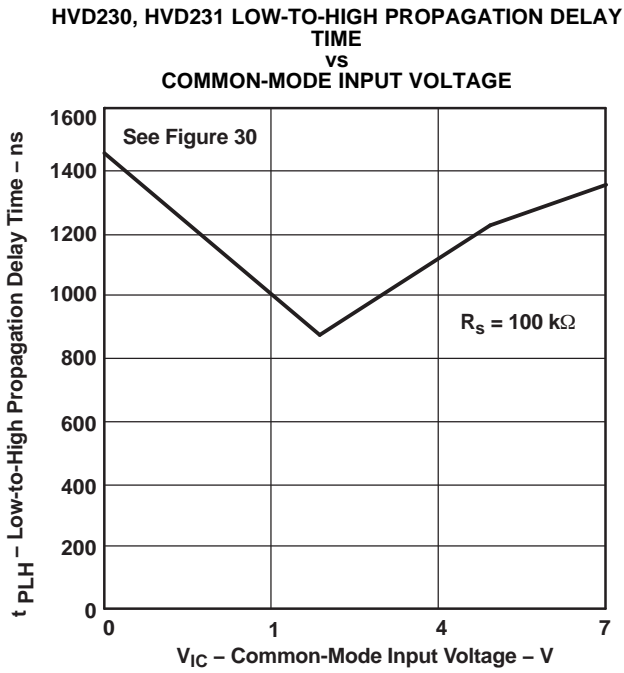


Figure 28.

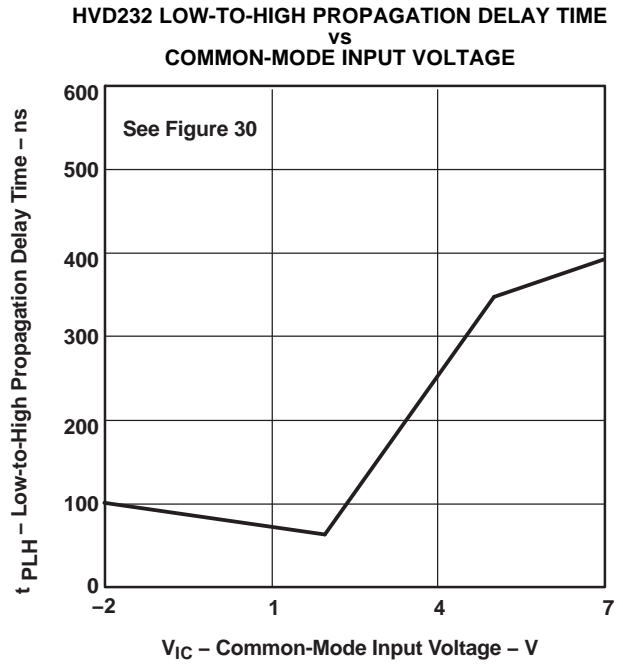


Figure 29.

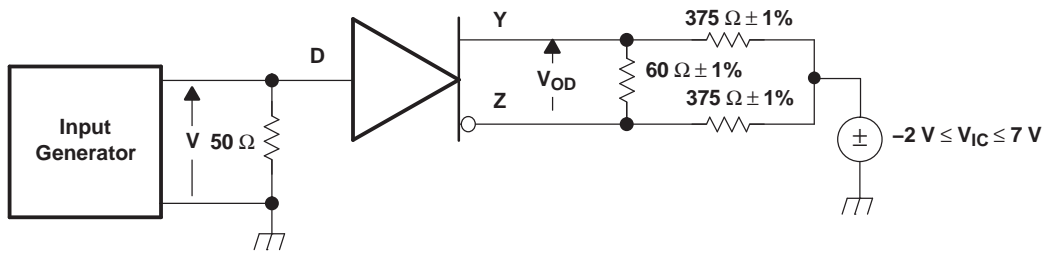


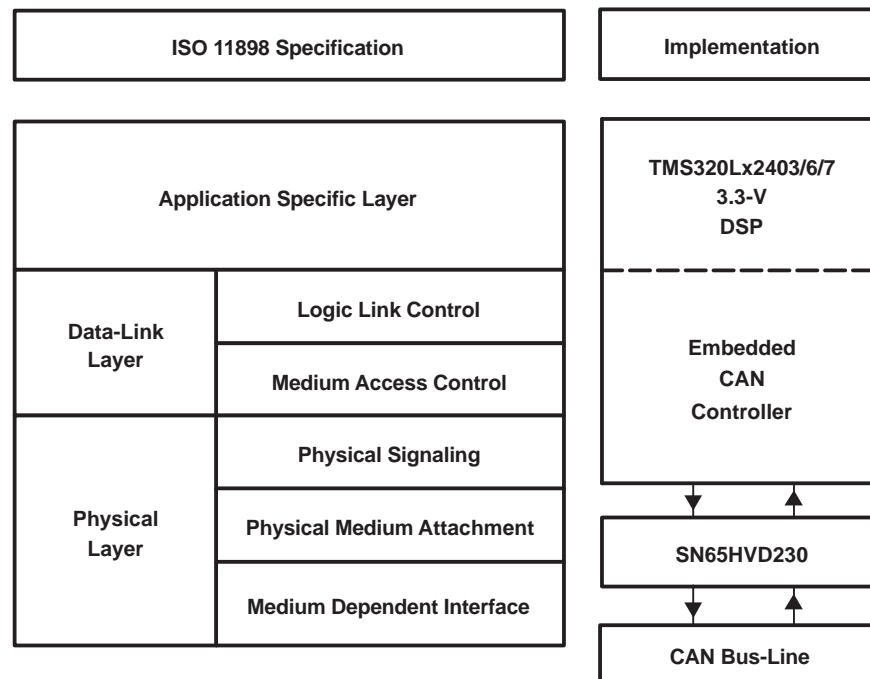
Figure 30. Driver Schematic

## APPLICATION INFORMATION

This application provides information concerning the implementation of the physical medium attachment layer in a CAN network according to the ISO 11898 standard. It presents a typical application circuit and test results, as well as discussions on slope control, total loop delay, and interoperability in 5-V systems.

### INTRODUCTION

ISO 11898 is the international standard for high-speed serial communication using the controller area network (CAN) bus protocol. It supports multimaster operation, real-time control, programmable data rates up to 1 Mbps, and powerful redundant error checking procedures that provide reliable data transmission. It is suited for networking *intelligent* devices as well as sensors and actuators within the rugged electrical environment of a machine chassis or factory floor. The SN65HVD230 family of 3.3-V CAN transceivers implement the lowest layers of the ISO/OSI reference model. This is the interface with the physical signaling output of the CAN controller of the Texas Instruments TMS320Lx240x 3.3-V DSPs, as illustrated in [Figure 31](#).



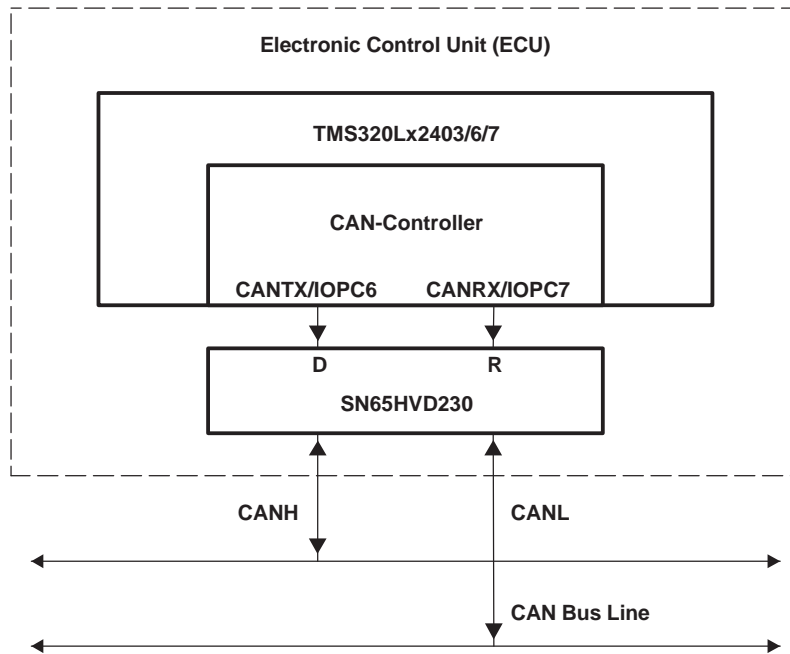
**Figure 31. The Layered ISO 11898 Standard Architecture**

The SN65HVD230 family of CAN transceivers are compatible with the ISO 11898 standard; this ensures interoperability with other standard-compliant products.

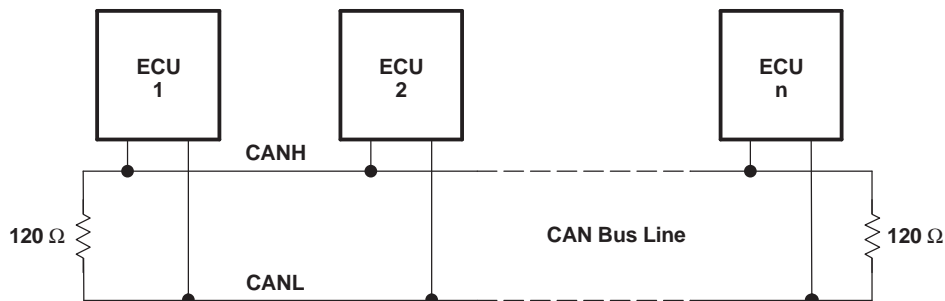
### APPLICATION OF THE SN65HVD230

[Figure 32](#) illustrates a typical application of the SN65HVD230 family. The output of a DSP's CAN controller is connected to the serial driver input, pin D, and receiver serial output, pin R, of the transceiver. The transceiver is then attached to the differential bus lines at pins CANH and CANL. Typically, the bus is a twisted pair of wires with a characteristic impedance of 120  $\Omega$ , in the standard half-duplex multipoint topology of [Figure 33](#). Each end of the bus is terminated with 120- $\Omega$  resistors in compliance with the standard to minimize signal reflections on the bus.

**APPLICATION INFORMATION (continued)**



**Figure 32. Details of a Typical CAN Node**



**Figure 33. Typical CAN Network**

The SN65HVD230/231/232 3.3-V CAN transceivers provide the interface between the 3.3-V TMS320Lx2403/6/7 CAN DSPs and the differential bus line, and are designed to transmit data at signaling rates up to 1 Mbps as defined by the ISO 11898 standard.

**FEATURES of the SN65HVD230, SN65HVD231, and SN65HVD232**

The SN65HVD230/231/232 are pin-compatible (but not functionally identical) with one another and, depending upon the application, may be used with identical circuit boards.

These transceivers feature 3.3-V operation and standard compatibility with signaling rates up to 1 Mbps, and also offer 16-kV HBM ESD protection on the bus pins, thermal shutdown protection, bus fault protection, and open-circuit receiver failsafe. The fail-safe design of the receiver assures a logic high at the receiver output if the bus wires become open circuited. If a high ambient operating environment temperature or excessive output current result in thermal shutdown, the bus pins become high impedance, while the D and R pins default to a logic high.

## APPLICATION INFORMATION (continued)

The bus pins are also maintained in a high-impedance state during low  $V_{CC}$  conditions to ensure glitch-free power-up and power-down bus protection for hot-plugging applications. This high-impedance condition also means that an unpowered node does not disturb the bus. Transceivers without this feature usually have a very low output impedance. This results in a high current demand when the transceiver is unpowered, a condition that could affect the entire bus.

## OPERATING MODES

$R_S$  (pin 8) of the SN65HVD230 and SN65HVD231 provides for three different modes of operation: high-speed mode, slope-control mode, and low-power mode.

### High-Speed

The high-speed mode can be selected by applying a logic low to  $R_S$  (pin 8). The high-speed mode of operation is commonly employed in industrial applications. High-speed allows the output to switch as fast as possible with no internal limitation on the output rise and fall slopes. The only limitations of the high-speed operation are cable length and radiated emission concerns, each of which is addressed by the slope control mode of operation.

If the low-power standby mode is to be employed in the circuit, direct connection to a DSP output pin can be used to switch between a logic-low level ( $< 1\text{ V}$ ) for high speed operation, and the logic-high level ( $> 0.75 V_{CC}$ ) for standby. Figure 34 shows a typical DSP connection, and Figure 35 shows the HVD230 driver output signal in high-speed mode on the CAN bus.

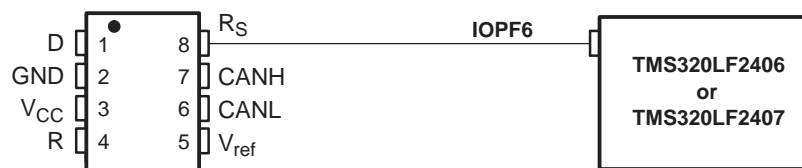


Figure 34.  $R_S$  (Pin 8) Connection to a TMS320LF2406/07 for High Speed/Standby Operation

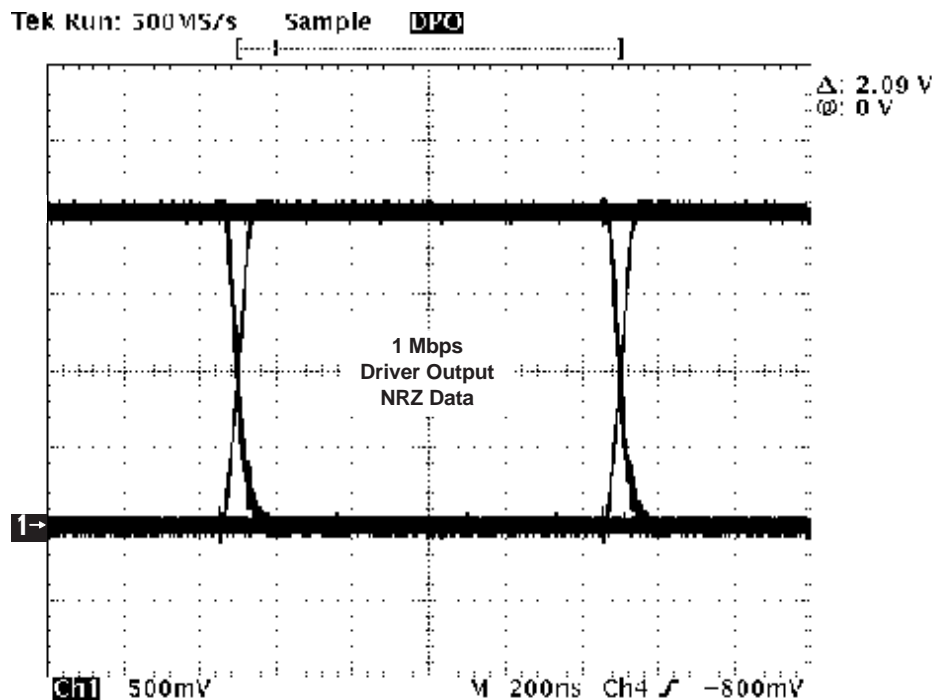


Figure 35. Typical High Speed SN65HVD230 Output Waveform Into a 60- $\Omega$  Load

## APPLICATION INFORMATION (continued)

### Slope Control

Electromagnetic compatibility is essential in many applications using unshielded bus cable to reduce system cost. To reduce the electromagnetic interference generated by fast rise times and resulting harmonics, the rise and fall slopes of the SN65HVD230 and SN65HVD231 driver outputs can be adjusted by connecting a resistor from  $R_S$  (pin 8) to ground or to a logic low voltage, as shown in Figure 36. The slope of the driver output signal is proportional to the pin's output current. This slope control is implemented with an external resistor value of  $10\text{ k}\Omega$  to achieve a  $\approx 15\text{ V}/\mu\text{s}$  slew rate, and up to  $100\text{ k}\Omega$  to achieve a  $\approx 2.0\text{ V}/\mu\text{s}$  slew rate as displayed in Figure 37. Typical driver output waveforms from a pulse input signal with and without slope control are displayed in Figure 38. A pulse input is used rather than NRZ data to clearly display the actual slew rate.

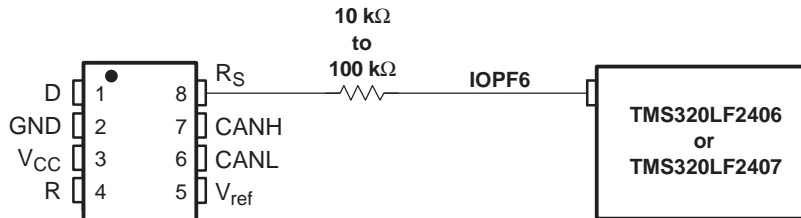


Figure 36. Slope Control/Standby Connection to a DSP

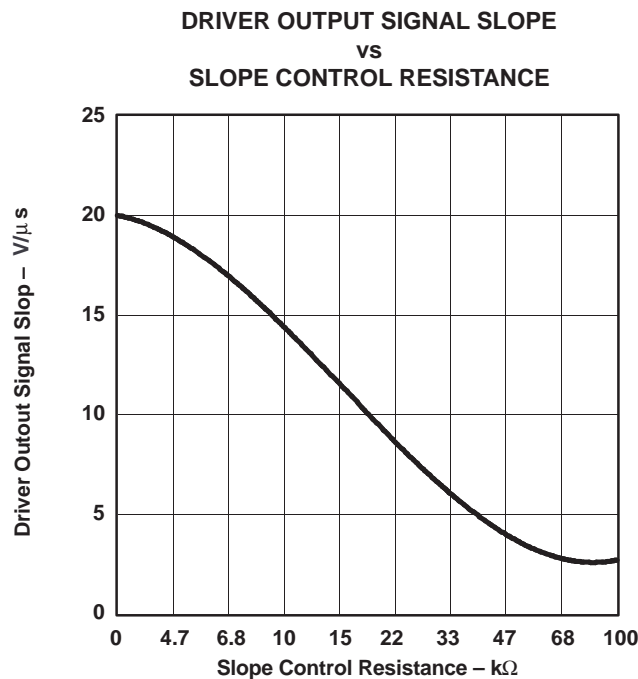


Figure 37. HVD230 Driver Output Signal Slope vs Slope Control Resistance Value

## APPLICATION INFORMATION (continued)

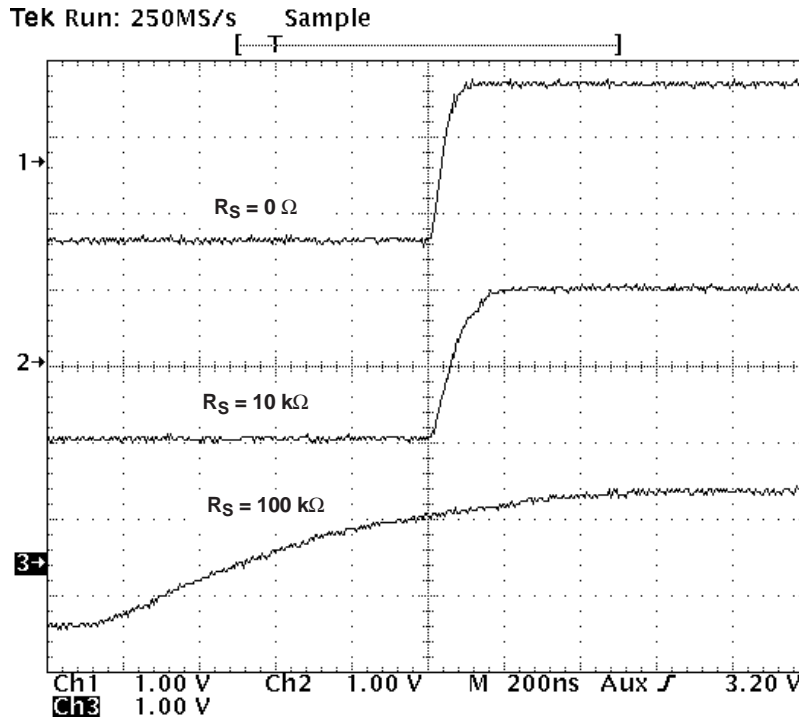


Figure 38. Typical SN65HVD230 250-kbps Output Pulse Waveforms With Slope Control

### Standby Mode (Listen Only Mode) of the HVD230

If a logic high ( $> 0.75 V_{CC}$ ) is applied to  $R_S$  (pin 8) in [Figure 34](#) and [Figure 36](#), the circuit of the SN65HVD230 enters a low-current, *listen only* standby mode, during which the driver is switched off and the receiver remains active. In this *listen only* state, the transceiver is completely passive to the bus. It makes no difference if a slope control resistor is in place as shown in [Figure 36](#). The DSP can reverse this low-power standby mode when the rising edge of a dominant state (bus differential voltage  $> 900$  mV typical) occurs on the bus. The DSP, sensing bus activity, reactivates the driver circuit by placing a logic low ( $< 1.2$  V) on  $R_S$  (pin 8).

### The Babbling Idiot Protection of the HVD230

Occasionally, a runaway CAN controller unintentionally sends messages that completely tie up the bus (what is referred to in CAN jargon as a babbling idiot). When this occurs, the DSP can engage the *listen-only* standby mode to disengage the driver and release the bus, even when access to the CAN controller has been lost. When the driver circuit is deactivated, its outputs default to a high-impedance state.

### Sleep Mode of the HVD231

The unique difference between the SN65HVD230 and the SN65HVD231 is that both driver and receiver are switched off in the SN65HVD231 when a logic high is applied to  $R_S$  (pin 8). The device remains in a very low power-sleep mode until the circuit is reactivated with a logic low applied to  $R_S$  (pin 8). While in this sleep mode, the bus-pins are in a high-impedance state, while the D and R pins default to a logic high.

## LOOP PROPAGATION DELAY

Transceiver loop delay is a measure of the overall device propagation delay, consisting of the delay from the driver input to the differential outputs, plus the delay from the receiver inputs to its output.

The loop delay of the transceiver displayed in [Figure 39](#) increases accordingly when slope control is being used. This increased loop delay means that the total bus length must be reduced to meet the CAN bit-timing requirements of the overall system. The loop delay becomes  $\approx 100$  ns when employing slope control with a

### APPLICATION INFORMATION (continued)

10-k $\Omega$  resistor, and  $\approx$  500 ns with a 100-k $\Omega$  resistor. Therefore, considering that the rule-of-thumb propagation delay of typical bus cable is 5 ns/m, slope control with the 100-k $\Omega$  resistor decreases the allowable bus length by the difference between the 500-ns max loop delay and the loop delay with no slope control, 70.7 ns. This equates to (500-70.7 ns)/5 ns, or approximately 86 m less bus length. This slew-rate/bus length trade-off to reduce electromagnetic interference to adjoining circuits from the bus can also be solved with a quality shielded bus cable.

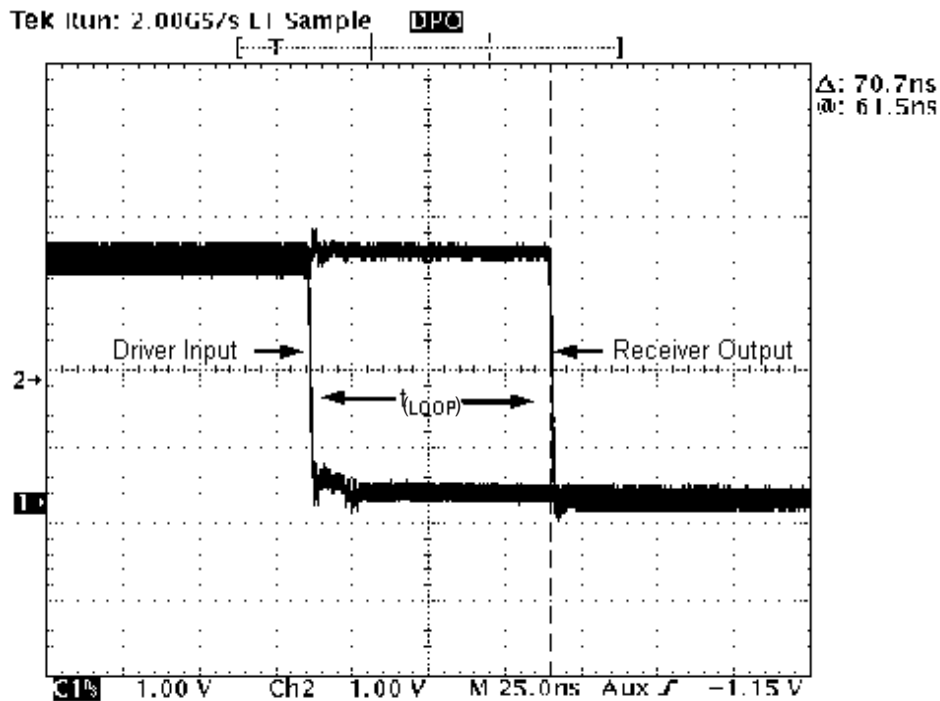
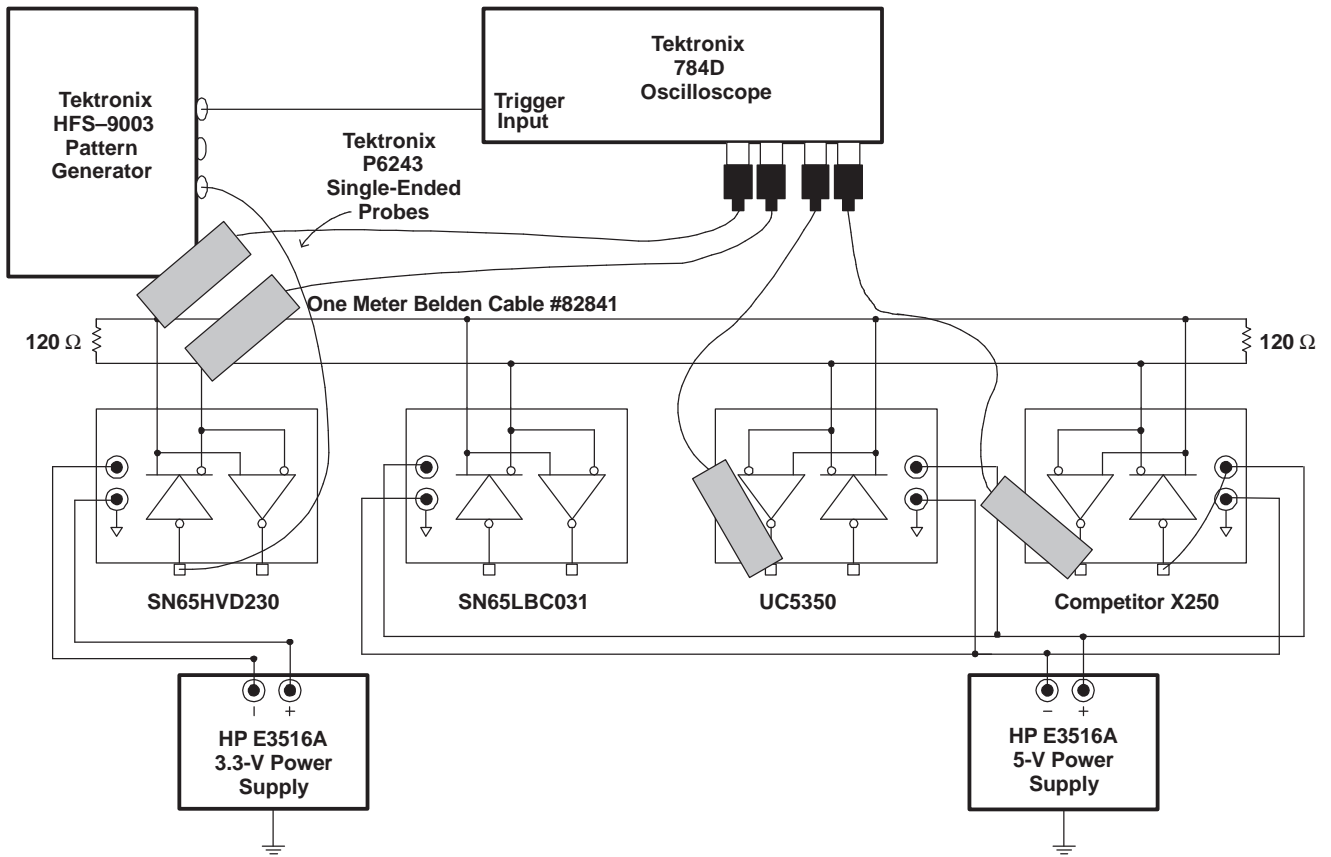


Figure 39. 70.7-ns Loop Delay Through the HVD230 With  $R_S = 0$

### INTEROPERABILITY WITH 5-V CAN SYSTEMS

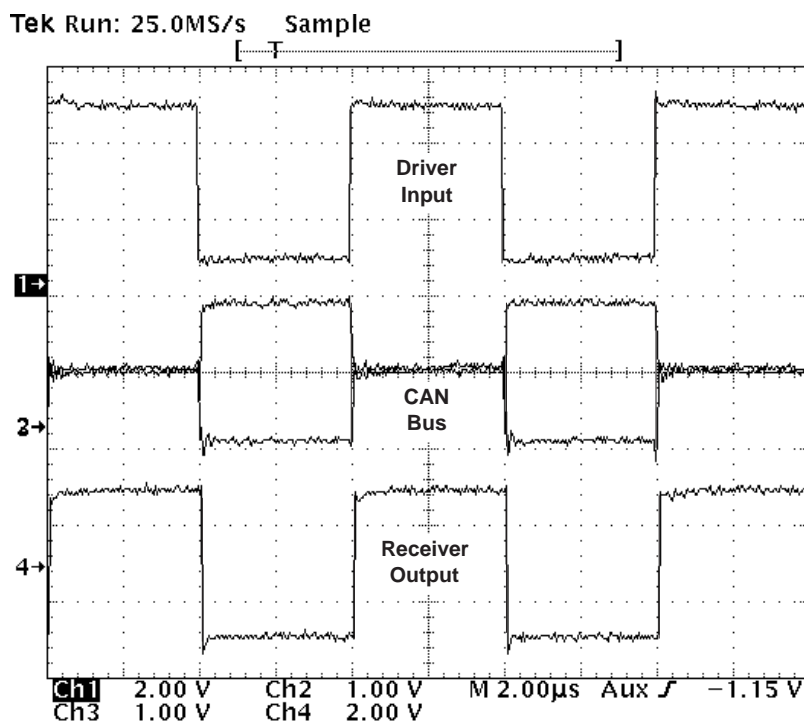
It is essential that the 3.3-V HVD230 family performs seamlessly with 5-V transceivers because of the large number of 5-V devices installed. Figure 40 displays a test bus of a 3.3-V node with the HVD230, and three 5-V nodes: one for each of TI's SN65LBC031 and UC5350 transceivers, and one using a competitor X250 transceiver.

**APPLICATION INFORMATION (continued)**



**Figure 40. 3.3-V/5-V CAN Transceiver Test Bed**

## APPLICATION INFORMATION (continued)



**Figure 41. The HVD230's Input, CAN Bus, and X250's RXD Output Waveforms**

Figure 41 displays the HVD230's input signal, the CAN bus, and the competitor X250's receiver output waveforms. The input waveform from the Tektronix HFS-9003 Pattern Generator in Figure 40 to the HVD230 is a 250-kbps pulse for this test. The circuit is monitored with Tektronix P6243, 1-GHz single-ended probes in order to display the CAN dominant and recessive bus states.

Figure 41 displays the 250-kbps pulse input waveform to the HVD230 on channel 1. Channels 2 and 3 display CANH and CANL respectively, with their recessive bus states overlaying each other to clearly display the dominant and recessive CAN bus states. Channel 4 is the receiver output waveform of the competitor X250.

PACKAGING INFORMATION

Orderable Device	Status <sup>(1)</sup>	Package Type	Package Drawing	Pins	Package Qty	Eco Plan <sup>(2)</sup>	Lead/Ball Finish	MSL Peak Temp <sup>(3)</sup>
SN65HVD230D	ACTIVE	SOIC	D	8	75	Green (RoHS & no Sb/Br)	CU NIPDAU	Level-1-260C-UNLIM
SN65HVD230DG4	ACTIVE	SOIC	D	8	75	Green (RoHS & no Sb/Br)	CU NIPDAU	Level-1-260C-UNLIM
SN65HVD230DR	ACTIVE	SOIC	D	8	2500	Green (RoHS & no Sb/Br)	CU NIPDAU	Level-1-260C-UNLIM
SN65HVD230DRG4	ACTIVE	SOIC	D	8	2500	Green (RoHS & no Sb/Br)	CU NIPDAU	Level-1-260C-UNLIM
SN65HVD231D	ACTIVE	SOIC	D	8	75	Green (RoHS & no Sb/Br)	CU NIPDAU	Level-1-260C-UNLIM
SN65HVD231DG4	ACTIVE	SOIC	D	8	75	Green (RoHS & no Sb/Br)	CU NIPDAU	Level-1-260C-UNLIM
SN65HVD231DR	ACTIVE	SOIC	D	8	2500	Green (RoHS & no Sb/Br)	CU NIPDAU	Level-1-260C-UNLIM
SN65HVD231DRG4	ACTIVE	SOIC	D	8	2500	Green (RoHS & no Sb/Br)	CU NIPDAU	Level-1-260C-UNLIM
SN65HVD232D	ACTIVE	SOIC	D	8	75	Green (RoHS & no Sb/Br)	CU NIPDAU	Level-1-260C-UNLIM
SN65HVD232DG4	ACTIVE	SOIC	D	8	75	Green (RoHS & no Sb/Br)	CU NIPDAU	Level-1-260C-UNLIM
SN65HVD232DR	ACTIVE	SOIC	D	8	2500	Green (RoHS & no Sb/Br)	CU NIPDAU	Level-1-260C-UNLIM
SN65HVD232DRG4	ACTIVE	SOIC	D	8	2500	Green (RoHS & no Sb/Br)	CU NIPDAU	Level-1-260C-UNLIM

<sup>(1)</sup> The marketing status values are defined as follows:

**ACTIVE:** Product device recommended for new designs.

**LIFEBUY:** TI has announced that the device will be discontinued, and a lifetime-buy period is in effect.

**NRND:** Not recommended for new designs. Device is in production to support existing customers, but TI does not recommend using this part in a new design.

**PREVIEW:** Device has been announced but is not in production. Samples may or may not be available.

**OBSOLETE:** TI has discontinued the production of the device.

<sup>(2)</sup> Eco Plan - The planned eco-friendly classification: Pb-Free (RoHS), Pb-Free (RoHS Exempt), or Green (RoHS & no Sb/Br) - please check <http://www.ti.com/productcontent> for the latest availability information and additional product content details.

**TBD:** The Pb-Free/Green conversion plan has not been defined.

**Pb-Free (RoHS):** TI's terms "Lead-Free" or "Pb-Free" mean semiconductor products that are compatible with the current RoHS requirements for all 6 substances, including the requirement that lead not exceed 0.1% by weight in homogeneous materials. Where designed to be soldered at high temperatures, TI Pb-Free products are suitable for use in specified lead-free processes.

**Pb-Free (RoHS Exempt):** This component has a RoHS exemption for either 1) lead-based flip-chip solder bumps used between the die and package, or 2) lead-based die adhesive used between the die and leadframe. The component is otherwise considered Pb-Free (RoHS compatible) as defined above.

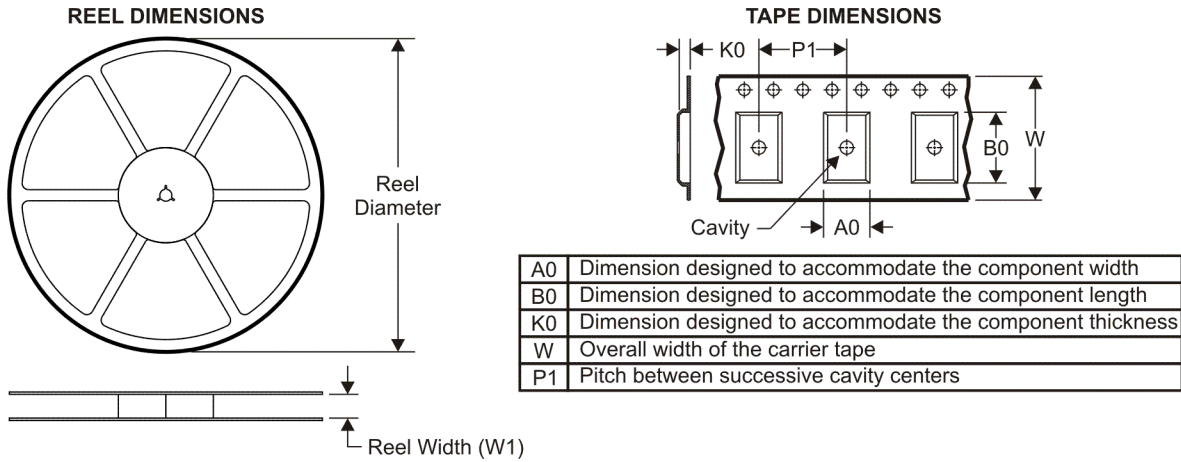
**Green (RoHS & no Sb/Br):** TI defines "Green" to mean Pb-Free (RoHS compatible), and free of Bromine (Br) and Antimony (Sb) based flame retardants (Br or Sb do not exceed 0.1% by weight in homogeneous material)

<sup>(3)</sup> MSL, Peak Temp. -- The Moisture Sensitivity Level rating according to the JEDEC industry standard classifications, and peak solder temperature.

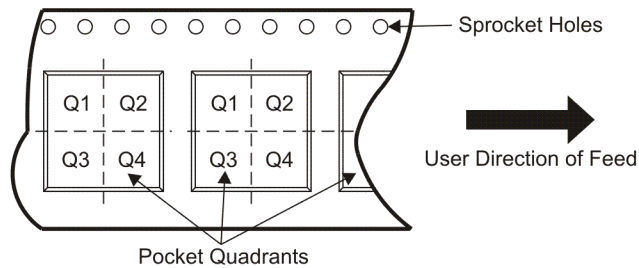
**Important Information and Disclaimer:**The information provided on this page represents TI's knowledge and belief as of the date that it is provided. TI bases its knowledge and belief on information provided by third parties, and makes no representation or warranty as to the accuracy of such information. Efforts are underway to better integrate information from third parties. TI has taken and continues to take reasonable steps to provide representative and accurate information but may not have conducted destructive testing or chemical analysis on incoming materials and chemicals. TI and TI suppliers consider certain information to be proprietary, and thus CAS numbers and other limited information may not be available for release.

In no event shall TI's liability arising out of such information exceed the total purchase price of the TI part(s) at issue in this document sold by TI to Customer on an annual basis.

**TAPE AND REEL INFORMATION**



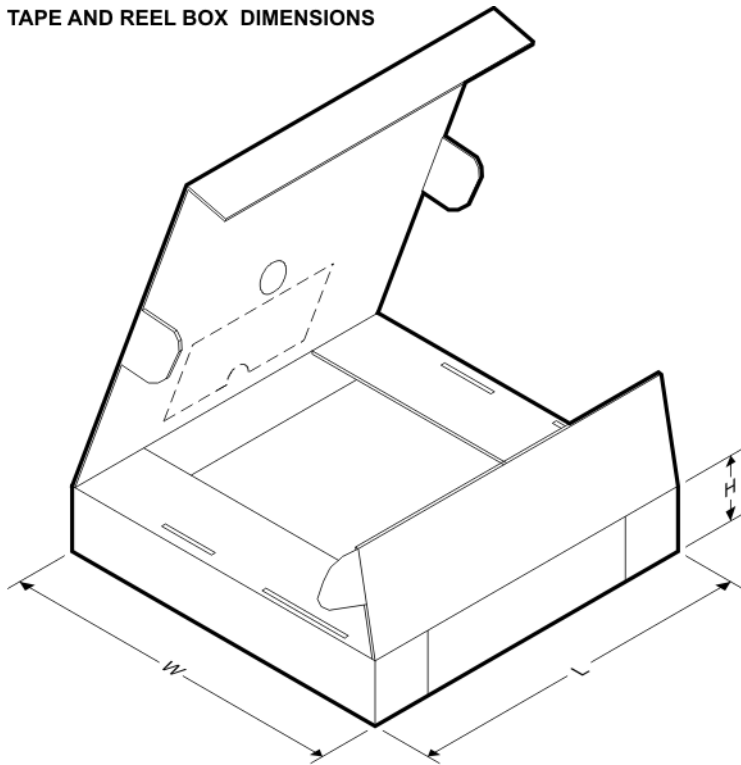
**QUADRANT ASSIGNMENTS FOR PIN 1 ORIENTATION IN TAPE**



\*All dimensions are nominal

Device	Package Type	Package Drawing	Pins	SPQ	Reel Diameter (mm)	Reel Width W1 (mm)	A0 (mm)	B0 (mm)	K0 (mm)	P1 (mm)	W (mm)	Pin1 Quadrant
SN65HVD230DR	SOIC	D	8	2500	330.0	12.4	6.4	5.2	2.1	8.0	12.0	Q1
SN65HVD231DR	SOIC	D	8	2500	330.0	12.4	6.4	5.2	2.1	8.0	12.0	Q1
SN65HVD232DR	SOIC	D	8	2500	330.0	12.4	6.4	5.2	2.1	8.0	12.0	Q1

**TAPE AND REEL BOX DIMENSIONS**

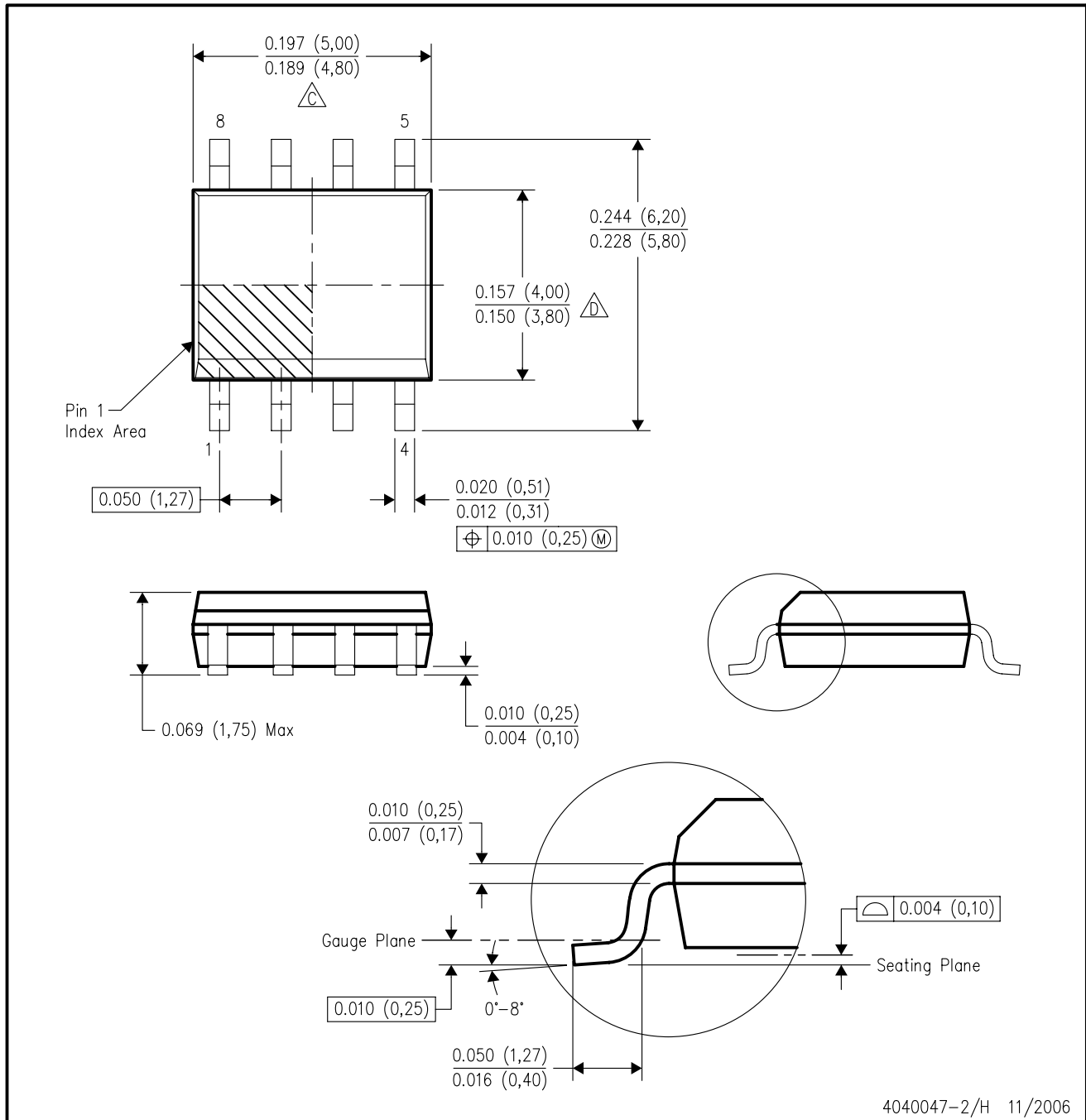


\*All dimensions are nominal

Device	Package Type	Package Drawing	Pins	SPQ	Length (mm)	Width (mm)	Height (mm)
SN65HVD230DR	SOIC	D	8	2500	340.5	338.1	20.6
SN65HVD231DR	SOIC	D	8	2500	340.5	338.1	20.6
SN65HVD232DR	SOIC	D	8	2500	340.5	338.1	20.6

D (R-PDSO-G8)

PLASTIC SMALL-OUTLINE PACKAGE



## IMPORTANT NOTICE

Texas Instruments Incorporated and its subsidiaries (TI) reserve the right to make corrections, modifications, enhancements, improvements, and other changes to its products and services at any time and to discontinue any product or service without notice. Customers should obtain the latest relevant information before placing orders and should verify that such information is current and complete. All products are sold subject to TI's terms and conditions of sale supplied at the time of order acknowledgment.

TI warrants performance of its hardware products to the specifications applicable at the time of sale in accordance with TI's standard warranty. Testing and other quality control techniques are used to the extent TI deems necessary to support this warranty. Except where mandated by government requirements, testing of all parameters of each product is not necessarily performed.

TI assumes no liability for applications assistance or customer product design. Customers are responsible for their products and applications using TI components. To minimize the risks associated with customer products and applications, customers should provide adequate design and operating safeguards.

TI does not warrant or represent that any license, either express or implied, is granted under any TI patent right, copyright, mask work right, or other TI intellectual property right relating to any combination, machine, or process in which TI products or services are used. Information published by TI regarding third-party products or services does not constitute a license from TI to use such products or services or a warranty or endorsement thereof. Use of such information may require a license from a third party under the patents or other intellectual property of the third party, or a license from TI under the patents or other intellectual property of TI.

Reproduction of TI information in TI data books or data sheets is permissible only if reproduction is without alteration and is accompanied by all associated warranties, conditions, limitations, and notices. Reproduction of this information with alteration is an unfair and deceptive business practice. TI is not responsible or liable for such altered documentation. Information of third parties may be subject to additional restrictions.

Resale of TI products or services with statements different from or beyond the parameters stated by TI for that product or service voids all express and any implied warranties for the associated TI product or service and is an unfair and deceptive business practice. TI is not responsible or liable for any such statements.

TI products are not authorized for use in safety-critical applications (such as life support) where a failure of the TI product would reasonably be expected to cause severe personal injury or death, unless officers of the parties have executed an agreement specifically governing such use. Buyers represent that they have all necessary expertise in the safety and regulatory ramifications of their applications, and acknowledge and agree that they are solely responsible for all legal, regulatory and safety-related requirements concerning their products and any use of TI products in such safety-critical applications, notwithstanding any applications-related information or support that may be provided by TI. Further, Buyers must fully indemnify TI and its representatives against any damages arising out of the use of TI products in such safety-critical applications.

TI products are neither designed nor intended for use in military/aerospace applications or environments unless the TI products are specifically designated by TI as military-grade or "enhanced plastic." Only products designated by TI as military-grade meet military specifications. Buyers acknowledge and agree that any such use of TI products which TI has not designated as military-grade is solely at the Buyer's risk, and that they are solely responsible for compliance with all legal and regulatory requirements in connection with such use.

TI products are neither designed nor intended for use in automotive applications or environments unless the specific TI products are designated by TI as compliant with ISO/TS 16949 requirements. Buyers acknowledge and agree that, if they use any non-designated products in automotive applications, TI will not be responsible for any failure to meet such requirements.

Following are URLs where you can obtain information on other Texas Instruments products and application solutions:

### Products

Amplifiers	<a href="http://amplifier.ti.com">amplifier.ti.com</a>
Data Converters	<a href="http://dataconverter.ti.com">dataconverter.ti.com</a>
DSP	<a href="http://dsp.ti.com">dsp.ti.com</a>
Clocks and Timers	<a href="http://www.ti.com/clocks">www.ti.com/clocks</a>
Interface	<a href="http://interface.ti.com">interface.ti.com</a>
Logic	<a href="http://logic.ti.com">logic.ti.com</a>
Power Mgmt	<a href="http://power.ti.com">power.ti.com</a>
Microcontrollers	<a href="http://microcontroller.ti.com">microcontroller.ti.com</a>
RFID	<a href="http://www.ti-rfid.com">www.ti-rfid.com</a>
RF/IF and ZigBee® Solutions	<a href="http://www.ti.com/lprf">www.ti.com/lprf</a>

### Applications

Audio	<a href="http://www.ti.com/audio">www.ti.com/audio</a>
Automotive	<a href="http://www.ti.com/automotive">www.ti.com/automotive</a>
Broadband	<a href="http://www.ti.com/broadband">www.ti.com/broadband</a>
Digital Control	<a href="http://www.ti.com/digitalcontrol">www.ti.com/digitalcontrol</a>
Medical	<a href="http://www.ti.com/medical">www.ti.com/medical</a>
Military	<a href="http://www.ti.com/military">www.ti.com/military</a>
Optical Networking	<a href="http://www.ti.com/opticalnetwork">www.ti.com/opticalnetwork</a>
Security	<a href="http://www.ti.com/security">www.ti.com/security</a>
Telephony	<a href="http://www.ti.com/telephony">www.ti.com/telephony</a>
Video & Imaging	<a href="http://www.ti.com/video">www.ti.com/video</a>
Wireless	<a href="http://www.ti.com/wireless">www.ti.com/wireless</a>

Mailing Address: Texas Instruments, Post Office Box 655303, Dallas, Texas 75265  
Copyright © 2008, Texas Instruments Incorporated