

HIGH-SPEED DIFFERENTIAL LINE TRANSCEIVERS

FEATURES

- **Sixteen Low-Voltage Differential Transceivers. Designed for Signaling Rates up to 200 Mbps per Receiver or 650 Mbps per Transmitter.**
- **Simplex (Point-to-Point) or Half-Duplex (Multipoint) Interface**
- **Typical Differential Output Voltage of 340 mV Into a 50-Ω Load**
- **Integrated 110-Ω Line Termination on 'LVDM1677 Product**
- **Propagation Delay Time:**
 - Driver: 2.5 ns Typ
 - Receiver: 3 ns Typ
- **Driver is High Impedance When Disabled or With $V_{CC} < 1.5$ V for Power Up/Down Glitch-Free Performance and Hot-Plugging Events**
- **Bus-Terminal ESD Protection Exceeds 12 kV**
- **Low-Voltage TTL (LVTTTL) Logic Input Levels Are 5-V Tolerant**
- **Packaged in Thin Shrink Small-Outline Package With 20 mil Terminal Pitch**

DESCRIPTION

The SN65LVDM1676 and SN65LVDM1677 (integrated termination) are sixteen differential line transmitters or receivers (transceivers) that use low-voltage differential signaling (LVDS) to achieve signaling rates up to 200 Mbps per transceiver configured as a receiver and up to 650 Mbps per transceiver configured as a transmitter. These products are similar to TIA/EIA-644 standard compliant devices (SN65LVDS) counterparts except that the output current of the drivers are doubled. This modification provides a minimum differential output voltage magnitude of 247 mV into a 50-Ω load and allows double-terminated lines and half-duplex operation. The receivers detect a voltage difference of 100 mV with up to 1 V of ground potential difference between a transmitter and receiver.

SN65LVDM1676DGG (Marked as LVDM1676)
SN65LVDM1677DGG (Marked as LVDM1677)
(TOP VIEW)

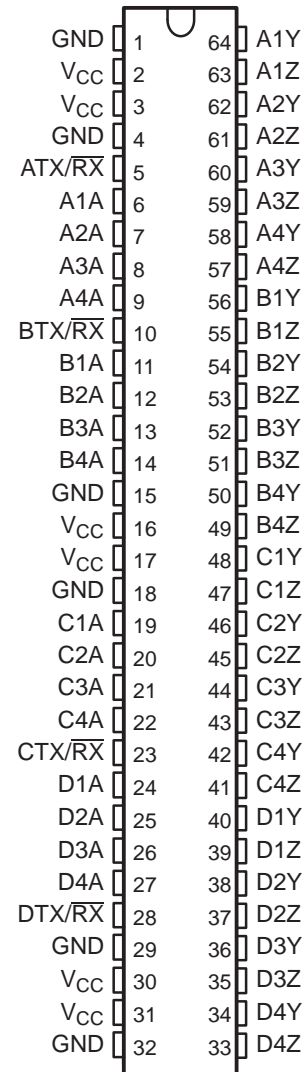

Please be aware that an important notice concerning availability, standard warranty, and use in critical applications of Texas Instruments semiconductor products and disclaimers thereto appears at the end of this data sheet.



These devices have limited built-in ESD protection. The leads should be shorted together or the device placed in conductive foam during storage or handling to prevent electrostatic damage to the MOS gates.

DESCRIPTION (CONTINUED)

The intended application of this device and signaling technique is for point-to-point baseband data transmission over controlled impedance media of approximately 100 Ω. The transmission media may be printed-circuit board traces, backplanes, or cables. The large number of transceivers integrated into the same substrate along with the low pulse skew of balanced signaling, allows extremely precise timing alignment of clock and data for synchronous parallel data transfers. (Note: The ultimate rate and distance of data transfer is dependent upon the attenuation characteristics of the media, the noise coupling to the environment, and other system characteristics.)

The SN65LVDM1676 and SN65LVDM1677 are characterized for operation from –40°C to 85°C.

FUNCTION TABLE⁽¹⁾

INPUTS			OUTPUTS		
(Y – Z)	TX/RX	A	Y	Z	A
$V_{ID} \geq 100 \text{ mV}$	L	NA	Z	Z	H
$-100 \text{ mV} < V_{ID} < 100 \text{ mV}$	L	NA	Z	Z	?
$V_{ID} \leq -100 \text{ mV}$	L	NA	Z	Z	L
Open circuit	L	NA	Z	Z	H
NA	H	L	L	H	Z
NA	H	H	H	L	Z

(1) H = high level, L= low level, Z= high impedance, ? = indeterminate

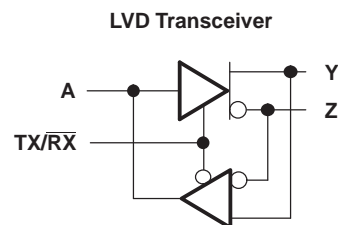

LOGIC DIAGRAM (POSITIVE LOGIC)

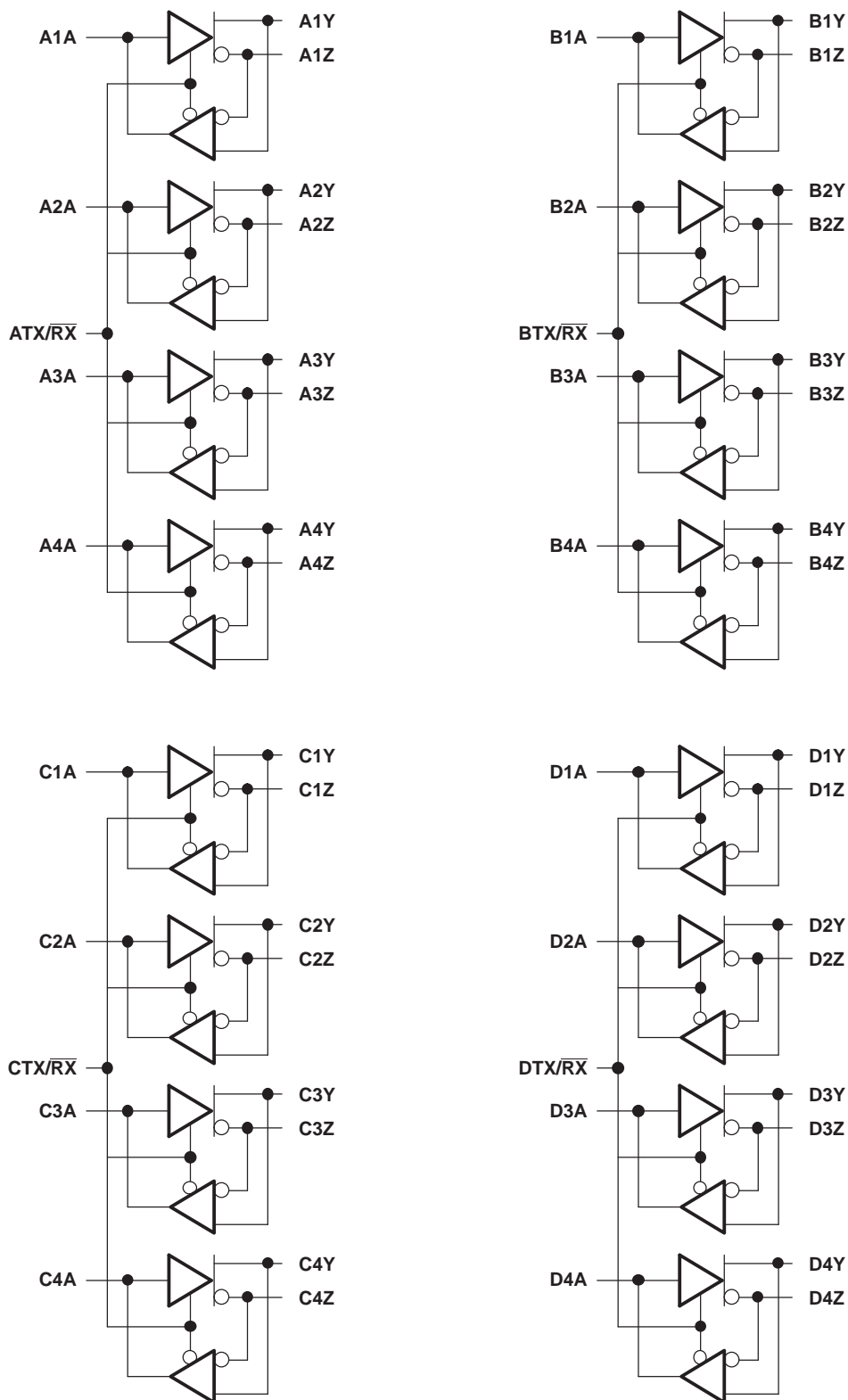

EQUIVALENT INPUT AND OUTPUT SCHEMATIC DIAGRAMS

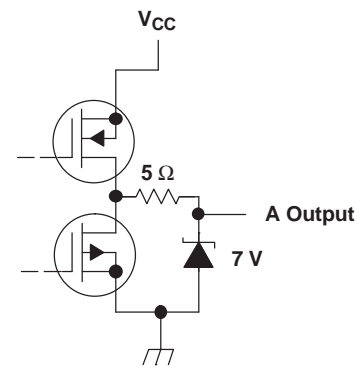
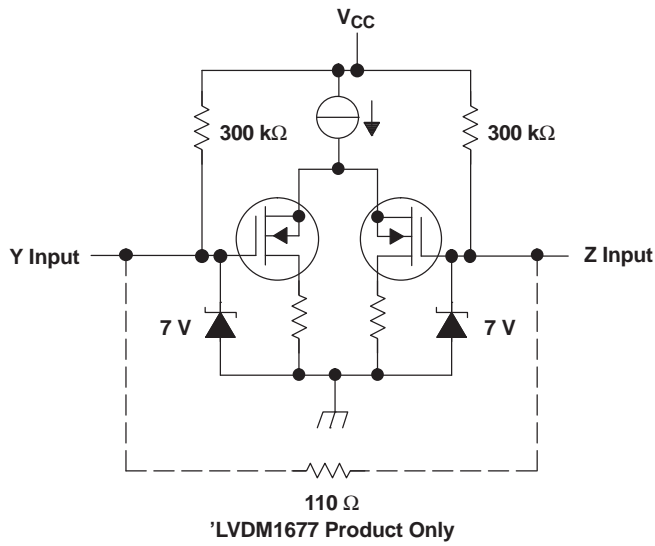
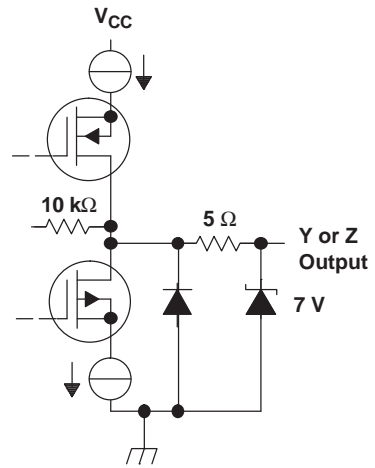
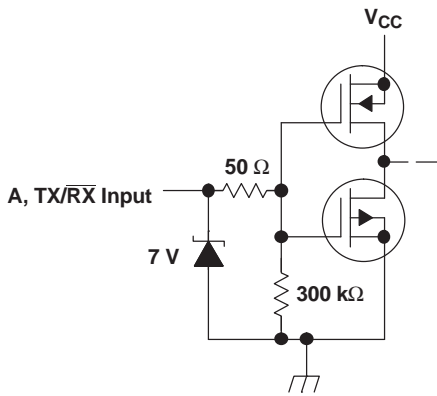

ABSOLUTE MAXIMUM RATINGS

over operating free-air temperature range (unless otherwise noted)⁽¹⁾⁽²⁾

		RATING	
V _{CC}	Supply voltage range	–0.5 V to 4 V	
V _I	Input voltage range	A, TX/RX	–0.5 V to 6 V
		Y or Z	–0.5 V to 4 V
V _{ID}	Differential input voltage magnitude, (SN65LVDM1677 only)	1 V	
I _O	Receiver output current	±20 mA	
P _D	Continuous power dissipation	See the Dissipation Rating Table	
ESD	Electrostatic discharge ⁽³⁾	Y, Z, and GND	Class 3, A: 8 kV, B: 600 V
		All Pins	Class 3, A: 7 kV, B: 500 V

- (1) Stresses beyond those listed under absolute maximum ratings may cause permanent damage to the device. These are stress ratings only, and functional operation of the device at these or any other conditions beyond those indicated under recommended operating conditions is not implied. Exposure to absolute-maximum-rated conditions for extended periods may affect device reliability.
- (2) All voltage values, except differential I/O bus voltages, are with respect to network ground terminal.
- (3) Tested in accordance with MIL-STD-883C Method 3015.7.

DISSIPATION RATING TABLE

PACKAGE	T _A ≤ 25°C POWER RATING	DERATING FACTOR ⁽¹⁾ ABOVE T _A = 25°C	T _A = 85°C POWER RATING
DGG	2094 mW	16.7 mW/°C	1089 mW

- (1) This is the inverse of the junction-to-ambient thermal resistance when board mounted and with no air flow.

RECOMMENDED OPERATING CONDITIONS

		MIN	NOM	MAX	UNIT
V _{CC}	Supply voltage	3	3.3	3.6	V
V _{IH}	High-level input voltage	2			
V _{IL}	Low-level input voltage	0.8			
V _{ID}	Magnitude of differential input voltage	0.1	0.6		
V _{IC}	Common-mode input voltage	$\frac{ V_{ID} }{2}$	$2.4 - \frac{ V_{ID} }{2}$		
		V _{CC} –0.8			V
I _{OL}	Receiver low-level output current	8			mA
I _{OH}	Receiver high-level output current	–8 ⁽¹⁾			
T _A	Operating free-air temperature	–40	85		°C

- (1) The algebraic convention in which the least positive (most negative) limit is designated as minimum is used in this data sheet.

ELECTRICAL CHARACTERISTICS

over recommended operating free-air temperature range (unless otherwise noted)

PARAMETER		TEST CONDITIONS	MIN	TYP ⁽¹⁾	MAX	UNIT	
DRIVER							
I _{CC}	Supply current	Driver enabled, receiver disabled R _L = 50 Ω ('LVDM1676) or R _L = 100 Ω ('LVDM1677)	140	175		mA	
		Driver disabled, receiver enabled, no load	45	60			
V _{OD}	Differential output voltage magnitude	R _L = 50 Ω ('LVDM1676) or R _L = 100 Ω ('LVDM1677), See Figure 2 and Figure 1	247	340	454	mV	
Δ V _{OD}	Change in differential output voltage magnitude between logic states		-50		50		
V _{OC(SS)}	Steady-state common-mode output voltage	R _L = 50 Ω ('LVDM1676) or R _L = 100 Ω ('LVDM1677), See Figure 3	1.125	1.37	5	V	
ΔV _{OC(S)}	Change in steady-state common-mode output voltage between logic states		-50		50	mV	
V _{OC(PP)}	Peak-to-peak common-mode output voltage		50		150	mV	
I _{IH}	High-level input current	V _{IH} = 2 V		3	20	μA	
I _{IL}	Low-level input current	V _{IL} = 0.8 V		2	10	μA	
I _{OS}	Short-circuit output current	V _{OY} or V _{OZ} = 0 V			10	mA	
		V _{OD} = 0 V			10		
I _{O(OFF)}	Power-off output current	V _{CC} = 1.5 V, V _O = 2.4 V	-10		10	μA	
C _{IN}	Input capacitance	V _I = 0.4 sin(4E6πt) + 0.5 V		5		pF	
RECEIVER							
V _{IT+}	Positive-going differential input voltage threshold	See Figure 6 and Table 1			100	mV	
V _{IT-}	Negative-going differential input voltage threshold		-100				
V _{OH}	High-level output voltage	I _{OH} = -8 mA	2.4			V	
V _{OL}	Low-level output voltage	I _{OL} = 8 mA			0.4	V	
I _I	Input current (Y or Z inputs)	V _{IY} = V _{Iz} = 0 V	-40	-24		μA	
		V _{IY} = V _{Iz} = 2.4 V		-8	-1.2		
I _{ID}	Differential input current I _{IY} - I _{Iz} (inputs)	'LVDM1676	V _{IY} = 0 V and V _{Iz} = 100 mV, V _{IY} = 2.4 V and V _{Iz} = 2.3 V		5	10	μA
		'LVDM1677	V _{IY} = 0.2 V and V _{Iz} = 0 V, V _{IY} = 2.4 V and V _{Iz} = 2.2 V		1.5	2.2	mA
I _{I(OFF)}	Power-off input current (Y or Z inputs)	V _{CC} = 0 V, V _I = 2.4 V	-25		25	μA	

(1) All typical values are at 25°C and with a 3.3-V supply.

SWITCHING CHARACTERISTICS

over recommended operating free-air temperature range (unless otherwise noted)

PARAMETER		TEST CONDITIONS	MIN	TYP ⁽¹⁾	MAX	UNIT	
DRIVER							
t_{PLH}	Propagation delay time, low-to-high-level output	$R_L = 50\ \Omega$ ('LVDM1676) or $R_L = 100\ \Omega$ ('LVDM1677), $C_L = 10\ \text{pF}$, See Figure 4	1.3	2.5	3.6	ns	
t_{PHL}	Propagation delay time, high-to-low-level output		1.3	2.5	3.6		
t_r	Differential output signal rise time		0.5	1.2			
t_f	Differential output signal fall time		0.5	1.2			
$t_{sk(p)}$	Pulse skew ($t_{PHL} - t_{PLH}$)		0.1	0.6			
$t_{sk(o)}$	Channel-to-channel output skew ⁽²⁾		0.1	0.4			
$t_{sk(pp)}$	Part-to-part skew ⁽³⁾			1			
t_{PZH}	Propagation delay time, high-impedance-to-high-level output		See Figure 5	11	20		
t_{PZL}	Propagation delay time, high-impedance-to-low-level output			10	20		
t_{PHZ}	Propagation delay time, high-level-to-high-impedance output			3	10		
t_{PLZ}	Propagation delay time, low-level-to-high-impedance output		3	10			
RECEIVER							
t_{PLH}	Propagation delay time, low-to-high-level output	$C_L = 10\ \text{pF}$, See Figure 7	1.5	3	4.5	ns	
t_{PHL}	Propagation delay time, high-to-low-level output		1.5	3	4.5		
t_r	Output signal rise time		0.6	1.6			
t_f	Output signal fall time		0.6	1.6			
$t_{sk(p)}$	Pulse skew ($t_{PHL} - t_{PLH}$)		0.2	0.8			
$t_{sk(o)}$	Channel-to-channel output skew ⁽⁴⁾		0.7	1.2			
$t_{sk(pp)}$	Part-to-part skew ⁽⁵⁾			1			
t_{PZH}	Propagation delay time, high-impedance-to-high-level output		See Figure 8	9	15		
t_{PZL}	Propagation delay time, high-impedance-to-low-level output			8	15		
t_{PHZ}	Propagation delay time, high-level-to-high-impedance output			12	20		
t_{PLZ}	Propagation delay time, low-level-to-high-impedance output		11	20			

(1) All typical values are at 25°C and with a 3.3-V supply.

(2) $t_{sk(o)}$ is the skew between specified outputs of a single device with all driving inputs connected together and the outputs switching in the same direction while driving identical specified loads.

(3) $t_{sk(pp)}$ is the magnitude of the difference in propagation delay times between any specified terminals of two devices when both devices operate with the same supply voltages, at the same temperature, and have identical packages and test circuits.

(4) $t_{sk(o)}$ is the skew between specified outputs of a single device with all driving inputs connected together and the outputs switching in the same direction while driving identical specified loads.

(5) $t_{sk(pp)}$ is the magnitude of the difference in propagation delay times between any specified terminals of two devices when both devices operate with the same supply voltages, at the same temperature, and have identical packages and test circuits.

PARAMETER MEASUREMENT INFORMATION

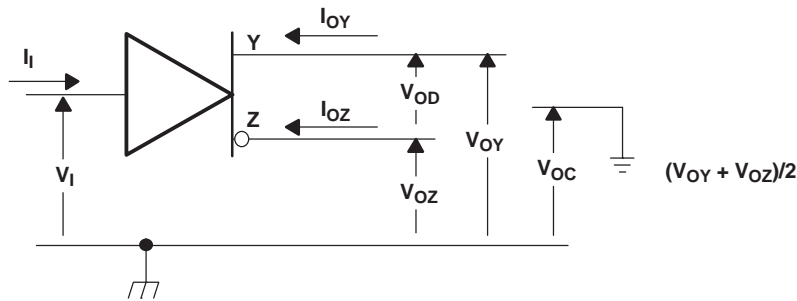

Figure 1. Driver Voltage and Current Definitions

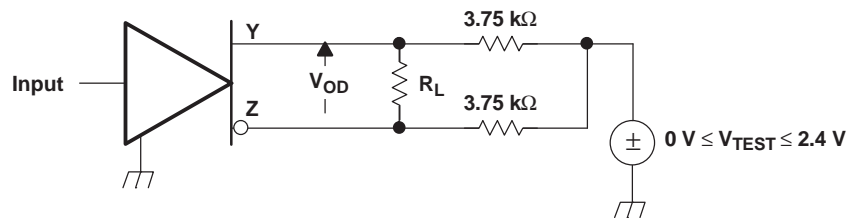
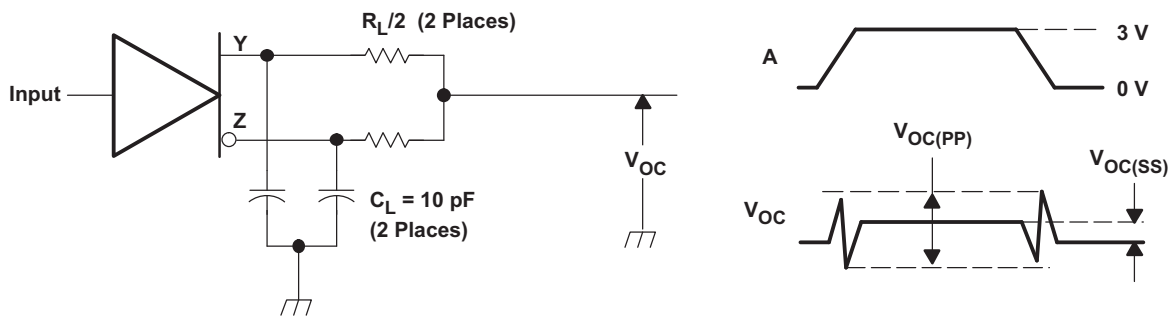

Figure 2. Driver V_{OD} Test Circuit



NOTE: All input pulses are supplied by a generator having the following characteristics: t_r or $t_f \leq 1$ ns, pulse repetition rate (PRR) = 0.5 Mpps, pulse width = 500 ± 10 ns. C_L includes instrumentation and fixture capacitance within 0,06 m of the D.U.T. The measurement of $V_{OC(PP)}$ is made on test equipment with a -3 dB bandwidth of at least 300 MHz.

Figure 3. Test Circuit and Definitions for the Driver Common-Mode Output Voltage

PARAMETER MEASUREMENT INFORMATION (continued)

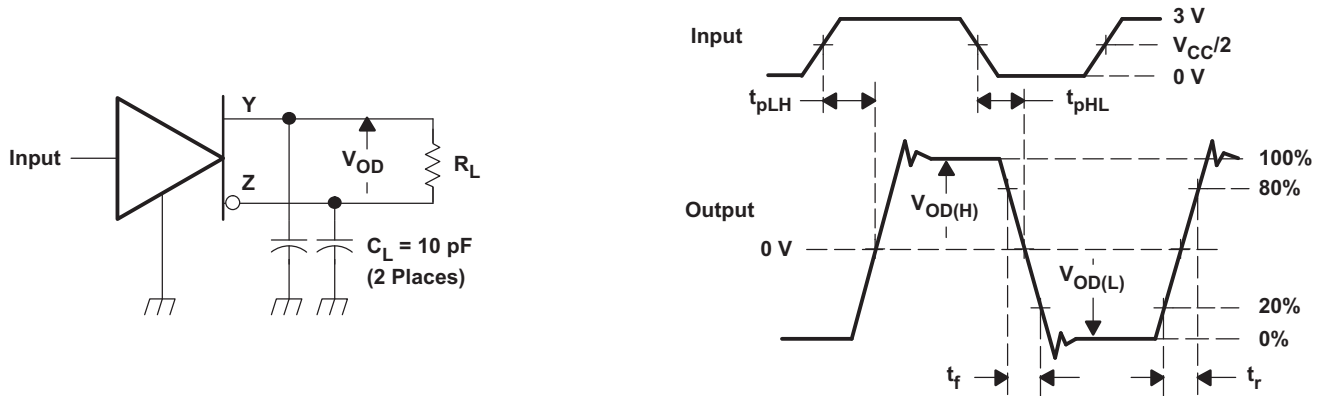

NOTE: All input pulses are supplied by a generator having the following characteristics: t_f or $t_r \leq 1$ ns, pulse repetition rate (PRR) = 0.5 Mpps, pulse width = 10 ± 0.2 ns. C_L includes instrumentation and fixture capacitance within 0,06 m of the D.U.T.

Figure 4. Test Circuit, Timing, and Voltage Definitions for the Differential Output Signal

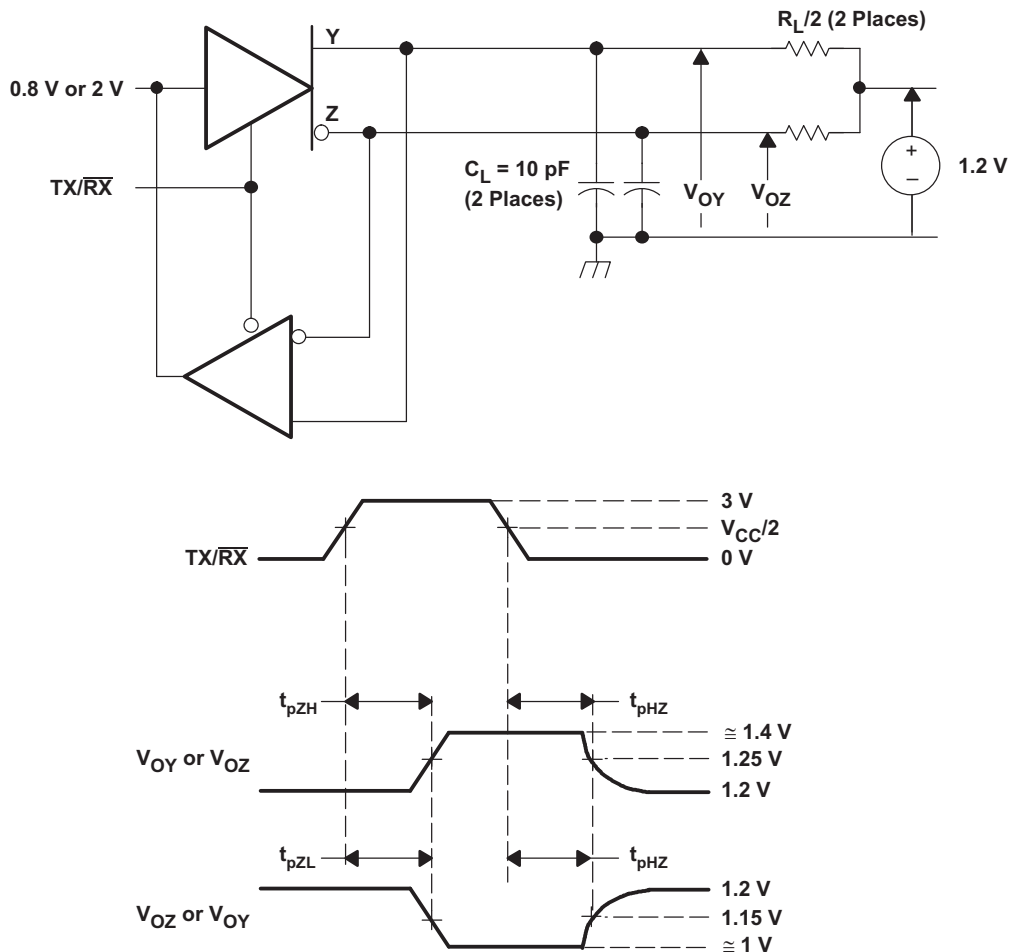

NOTE: All input pulses are supplied by a generator having the following characteristics: t_f or $t_r \leq 1$ ns, pulse repetition rate (PRR) = 0.5 Mpps, pulse width = 500 ± 10 ns. C_L includes instrumentation and fixture capacitance within 0,06 m of the D.U.T.

Figure 5. Enable and Disable Time Circuit and Definitions

PARAMETER MEASUREMENT INFORMATION (continued)

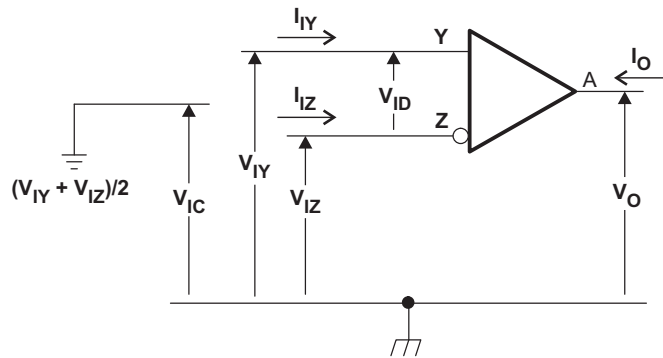
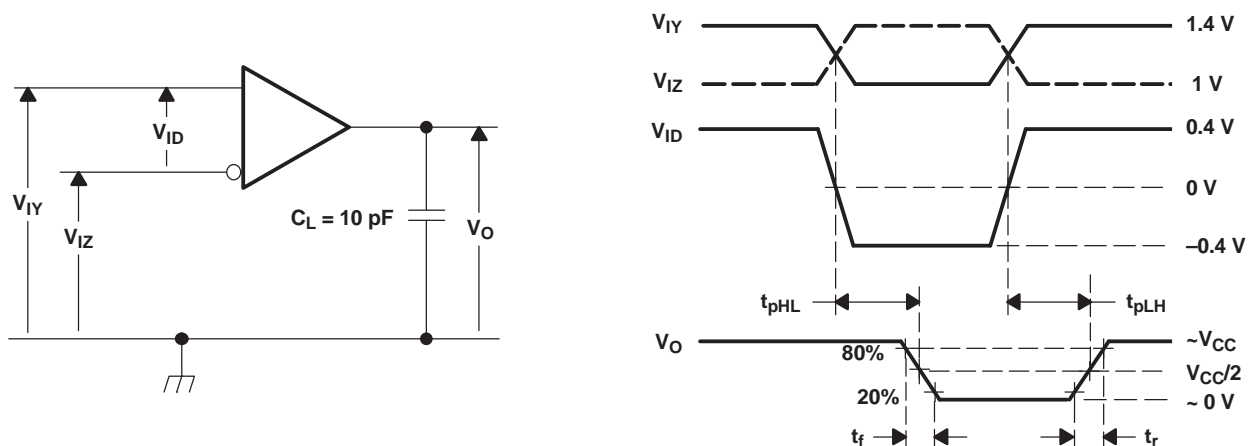

Figure 6. Voltage Definitions

Table 1. Receiver Minimum and Maximum Input Threshold Test Voltages

APPLIED VOLTAGES		RESULTING DIFFERENTIAL INPUT VOLTAGE	RESULTING COMMON-MODE INPUT VOLTAGE
V_{IY}	V_{IZ}	V_{ID}	V_{IC}
1.25 V	1.15 V	100 mV	1.2 V
1.15 V	1.25 V	-100 mV	1.2 V
2.4 V	2.3 V	100 mV	2.35 V
2.3 V	2.4 V	-100 mV	2.35 V
0.1 V	0 V	100 mV	0.05 V
0 V	0.1 V	-100 mV	0.05 V
1.5 V	0.9 V	600 mV	1.2 V
0.9 V	1.5 V	-600 mV	1.2 V
2.4 V	1.8 V	600 mV	2.1 V
1.8 V	2.4 V	-600 mV	2.1 V
0.6 V	0 V	600 mV	0.3 V
0 V	0.6 V	-600 mV	0.3 V



NOTE: All input pulses are supplied by a generator having the following characteristics: t_r or $t_f \leq 1$ ns, pulse repetition rate (PRR) = 0.5 Mpps, pulse width = 10 ± 0.2 ns. C_L includes instrumentation and fixture capacitance within 0,06 m of the D.U.T.

Figure 7. Timing Test Circuit and Waveforms

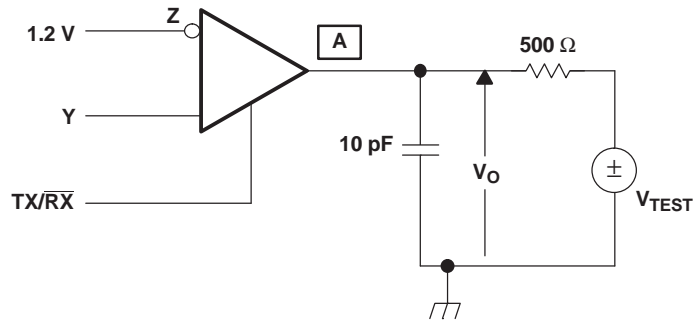

NOTE: All input pulses are supplied by a generator having the following characteristics: t_r or $t_f \leq 1$ ns, pulse repetition rate (PRR) = 0.5 Mpps, pulse width = 500 ± 10 ns. C_L includes instrumentation and fixture capacitance within 0,06 m of the D.U.T.

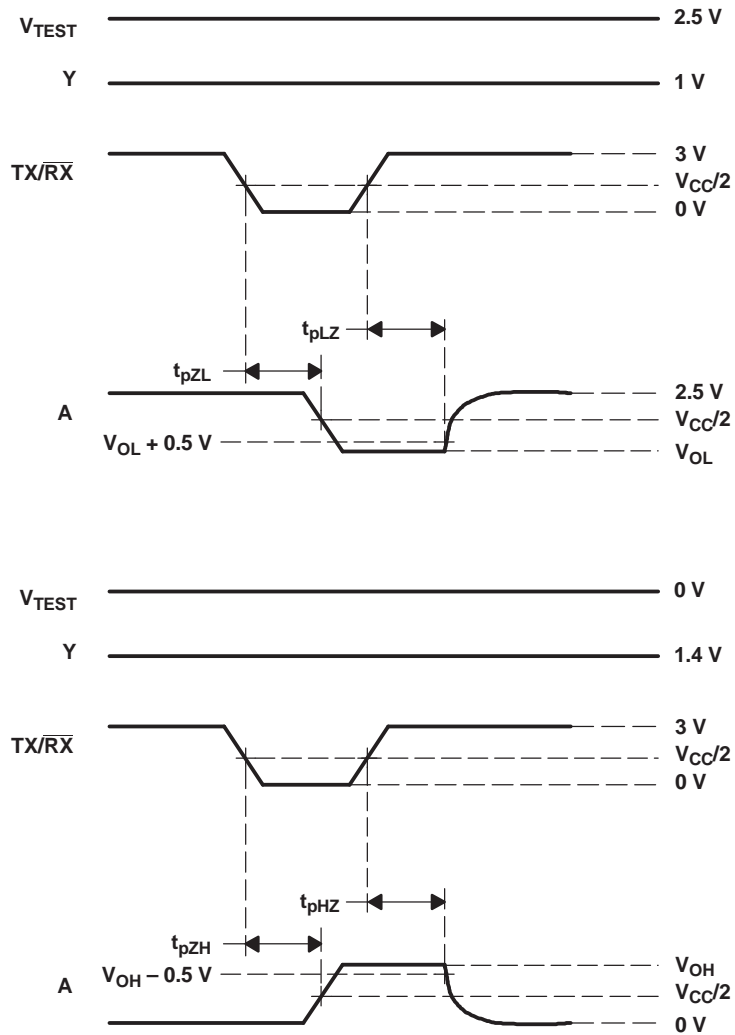
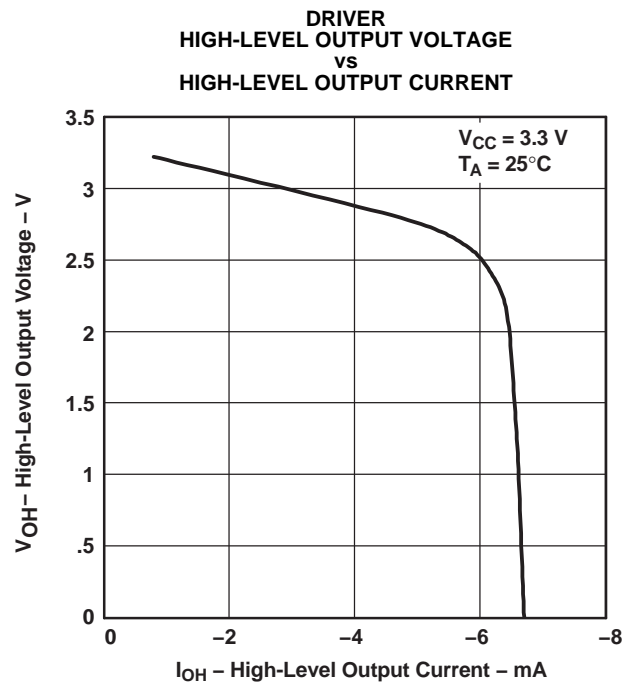
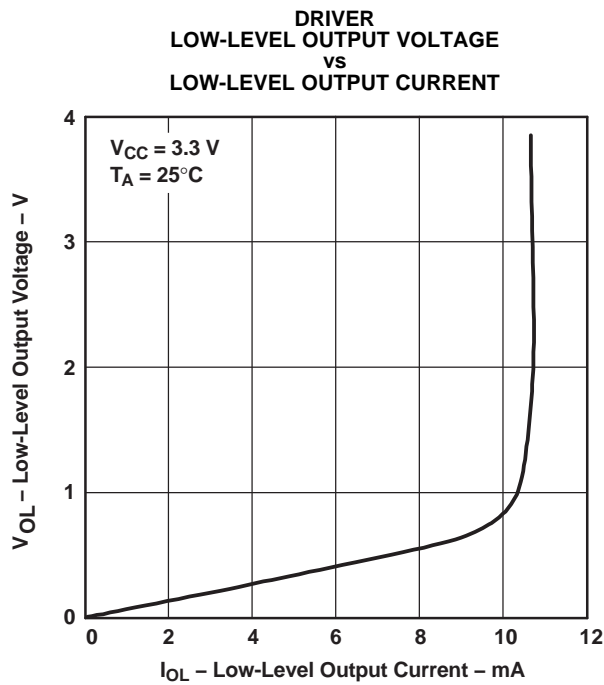
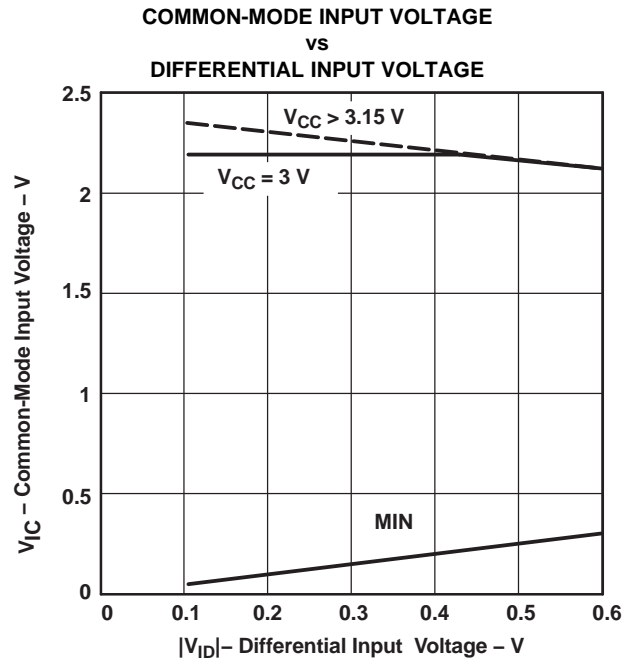

Figure 8. Enable/Disable Time Test Circuit and Waveforms

TYPICAL CHARACTERISTICS



TYPICAL CHARACTERISTICS (continued)

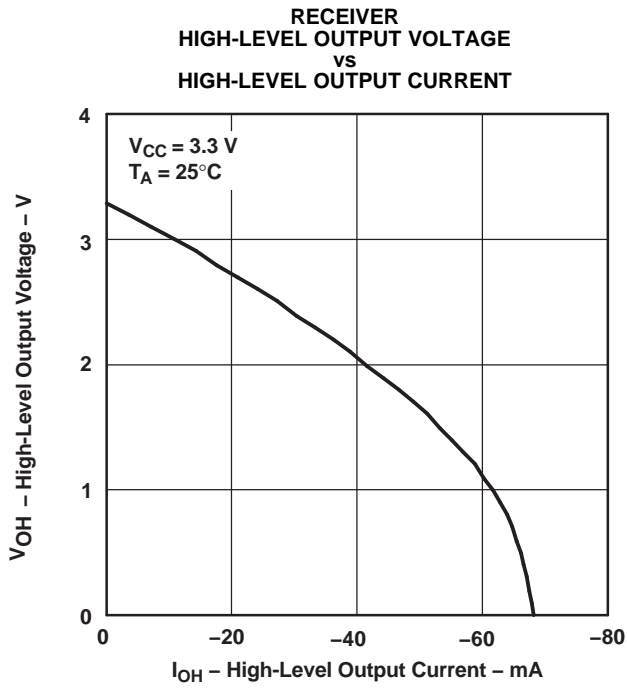

Figure 12.

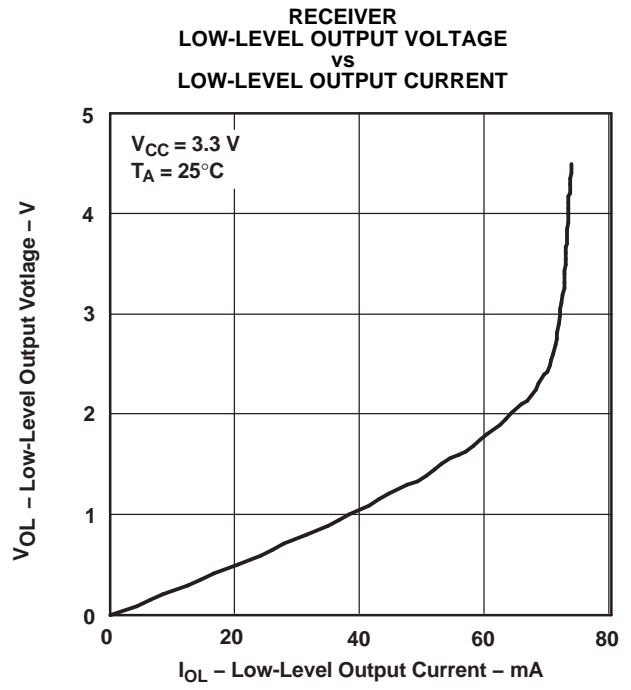

Figure 13.

TYPICAL CHARACTERISTICS (continued)

DRIVER EYE PATTERN

TEST CONDITIONS

- $V_{CC} = 3.6\text{ V}$
- $T_A = 25^\circ\text{C}$ (ambient temperature)
- All 16 channels switching simultaneously with NRZ data. Scope is triggered at the same frequency with pulse. Input signal level = 0 V to 3 V single ended.
- Resistive loading with no added capacitance

EQUIPMENT

- Hewlett Packard HP6624A DC power supply
- Tektronix TDS6604 Digital Storage Scope
- Agilent ParBERT E4832A

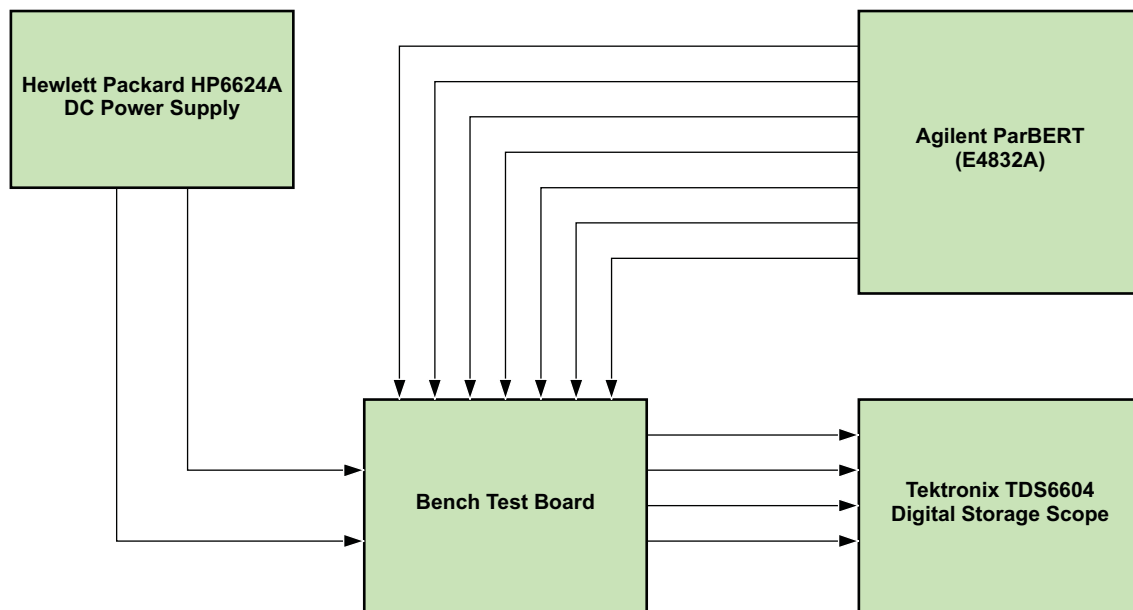
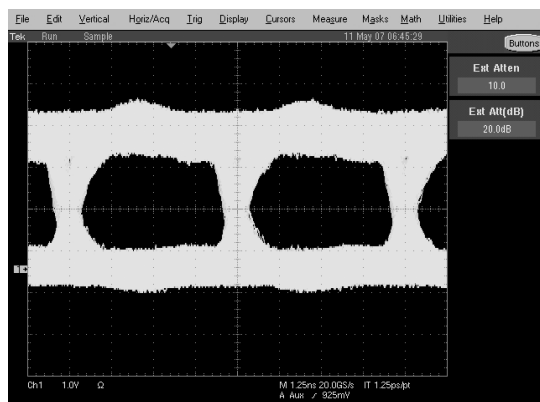
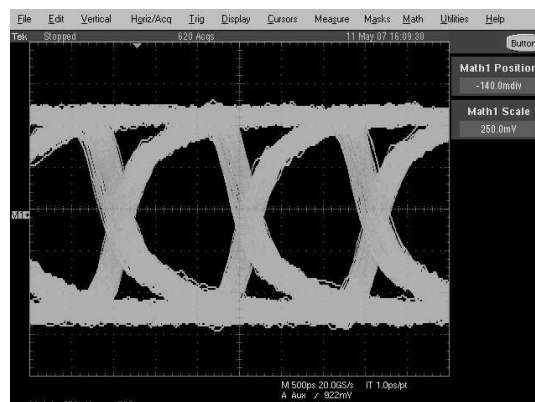

Figure 14. Equipment Setup

TYPICAL CHARACTERISTICS (continued)



(a) representative Transceiver configured as Rx @ 200 Mbps (Ch1 = xyA)



(b) representative Transceiver configured as Tx @ 650 Mbps (M1 = xyY-xyZ)

NOTE: x represents transceiver group A, B, C, or D, and y represents transceiver 1, 2, 3, or 4.

Figure 15. Typical Driver Eye Pattern for the SN65LVDM1676 With 12 Transceivers Configured as Rx and 4 Transceivers Configured as Tx all Switching Frequency Asynchronous Data
 ($T_A = 25^\circ\text{C}$; $V_{CC} = 3.6\text{ V}$; PRBS = $2^{23}-1$)

APPLICATION INFORMATION

FAIL SAFE

One of the most common problems with differential signaling applications is how the system responds when no differential voltage is present on the signal pair. The LVDS receiver is like most differential line receivers, in that its output logic state can be indeterminate when the differential input voltage is between -50 mV and 50 mV and within its recommended input common-mode voltage range. TI's LVDS receiver is different, however, in how it handles the open-input circuit situation.

Open-circuit means that there is little or no input current to the receiver from the data line itself. This could be when the driver is in a high-impedance state or the cable is disconnected. When this occurs, the LVDS receiver will pull each line of the signal pair to near V_{CC} through $300\text{-k}\Omega$ resistors as shown in Figure 16. The fail-safe feature uses an AND gate with input voltage thresholds at about 2.3 V to detect this condition and force the output to a high-level, regardless of the differential input voltage.

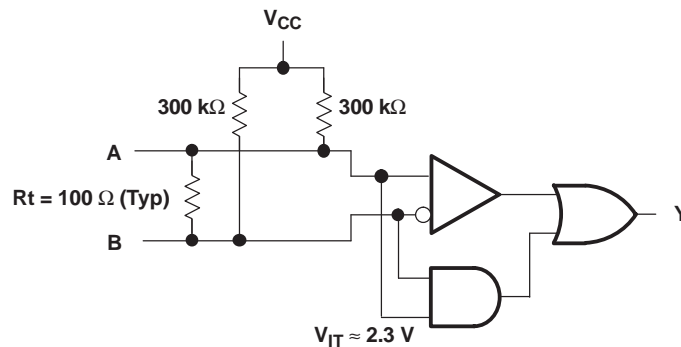

Figure 16. Open-Circuit Fail Safe of the LVDS Receiver

It is only under these conditions that the output of the receiver will be valid with less than a 50-mV differential input voltage magnitude. The presence of the termination resistor, R_t , does not affect the fail-safe function as long as it is connected as shown in the figure. Other termination circuits may allow a dc current to ground that could defeat the pullup currents from the receiver and the fail-safe feature.

PACKAGING INFORMATION

Orderable Device	Status ⁽¹⁾	Package Type	Package Drawing	Pins	Package Qty	Eco Plan ⁽²⁾	Lead/Ball Finish	MSL Peak Temp ⁽³⁾
SN65LVDM1676DGG	ACTIVE	TSSOP	DGG	64	25	Green (RoHS & no Sb/Br)	CU NIPDAU	Level-2-260C-1 YEAR
SN65LVDM1676DGGG4	ACTIVE	TSSOP	DGG	64	25	Green (RoHS & no Sb/Br)	CU NIPDAU	Level-2-260C-1 YEAR
SN65LVDM1676DGGR	ACTIVE	TSSOP	DGG	64	2000	Green (RoHS & no Sb/Br)	CU NIPDAU	Level-2-260C-1 YEAR
SN65LVDM1676DGGRG4	ACTIVE	TSSOP	DGG	64	2000	Green (RoHS & no Sb/Br)	CU NIPDAU	Level-2-260C-1 YEAR
SN65LVDM1677DGG	ACTIVE	TSSOP	DGG	64	25	Green (RoHS & no Sb/Br)	CU NIPDAU	Level-2-260C-1 YEAR
SN65LVDM1677DGGG4	ACTIVE	TSSOP	DGG	64	25	Green (RoHS & no Sb/Br)	CU NIPDAU	Level-2-260C-1 YEAR
SN65LVDM1677DGGR	ACTIVE	TSSOP	DGG	64	2000	Green (RoHS & no Sb/Br)	CU NIPDAU	Level-2-260C-1 YEAR
SN65LVDM1677DGGRG4	ACTIVE	TSSOP	DGG	64	2000	Green (RoHS & no Sb/Br)	CU NIPDAU	Level-2-260C-1 YEAR

⁽¹⁾ The marketing status values are defined as follows:

ACTIVE: Product device recommended for new designs.

LIFEBUY: TI has announced that the device will be discontinued, and a lifetime-buy period is in effect.

NRND: Not recommended for new designs. Device is in production to support existing customers, but TI does not recommend using this part in a new design.

PREVIEW: Device has been announced but is not in production. Samples may or may not be available.

OBSOLETE: TI has discontinued the production of the device.

⁽²⁾ Eco Plan - The planned eco-friendly classification: Pb-Free (RoHS), Pb-Free (RoHS Exempt), or Green (RoHS & no Sb/Br) - please check <http://www.ti.com/productcontent> for the latest availability information and additional product content details.

TBD: The Pb-Free/Green conversion plan has not been defined.

Pb-Free (RoHS): TI's terms "Lead-Free" or "Pb-Free" mean semiconductor products that are compatible with the current RoHS requirements for all 6 substances, including the requirement that lead not exceed 0.1% by weight in homogeneous materials. Where designed to be soldered at high temperatures, TI Pb-Free products are suitable for use in specified lead-free processes.

Pb-Free (RoHS Exempt): This component has a RoHS exemption for either 1) lead-based flip-chip solder bumps used between the die and package, or 2) lead-based die adhesive used between the die and leadframe. The component is otherwise considered Pb-Free (RoHS compatible) as defined above.

Green (RoHS & no Sb/Br): TI defines "Green" to mean Pb-Free (RoHS compatible), and free of Bromine (Br) and Antimony (Sb) based flame retardants (Br or Sb do not exceed 0.1% by weight in homogeneous material)

⁽³⁾ MSL, Peak Temp. -- The Moisture Sensitivity Level rating according to the JEDEC industry standard classifications, and peak solder temperature.

Important Information and Disclaimer:The information provided on this page represents TI's knowledge and belief as of the date that it is provided. TI bases its knowledge and belief on information provided by third parties, and makes no representation or warranty as to the accuracy of such information. Efforts are underway to better integrate information from third parties. TI has taken and continues to take reasonable steps to provide representative and accurate information but may not have conducted destructive testing or chemical analysis on incoming materials and chemicals. TI and TI suppliers consider certain information to be proprietary, and thus CAS numbers and other limited information may not be available for release.

In no event shall TI's liability arising out of such information exceed the total purchase price of the TI part(s) at issue in this document sold by TI to Customer on an annual basis.

TAPE AND REEL INFORMATION

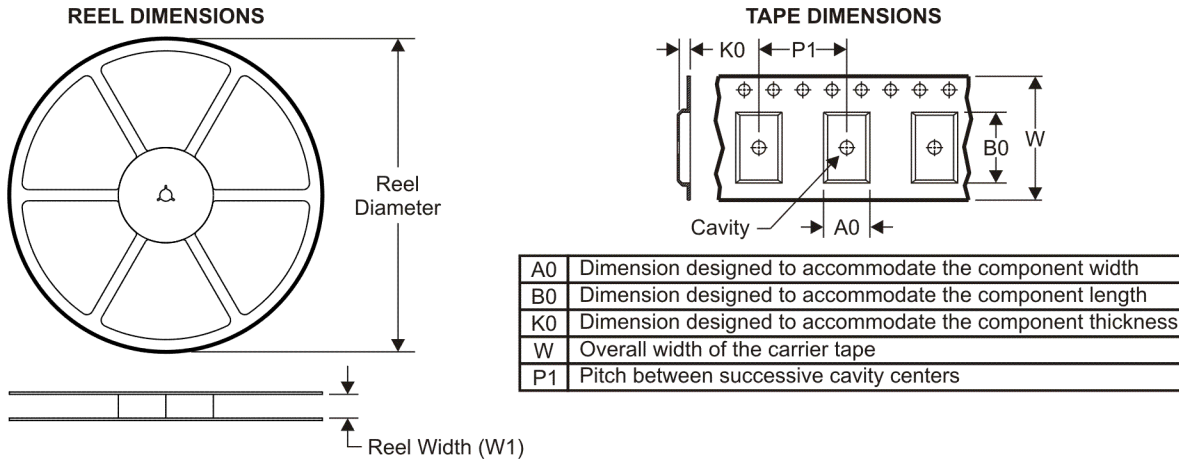

QUADRANT ASSIGNMENTS FOR PIN 1 ORIENTATION IN TAPE



*All dimensions are nominal

Device	Package Type	Package Drawing	Pins	SPQ	Reel Diameter (mm)	Reel Width W1 (mm)	A0 (mm)	B0 (mm)	K0 (mm)	P1 (mm)	W (mm)	Pin1 Quadrant
SN65LVDM1676DGGR	TSSOP	DGG	64	2000	330.0	24.4	8.4	17.3	1.7	12.0	24.0	Q1
SN65LVDM1677DGGR	TSSOP	DGG	64	2000	330.0	24.4	8.4	17.3	1.7	12.0	24.0	Q1

TAPE AND REEL BOX DIMENSIONS

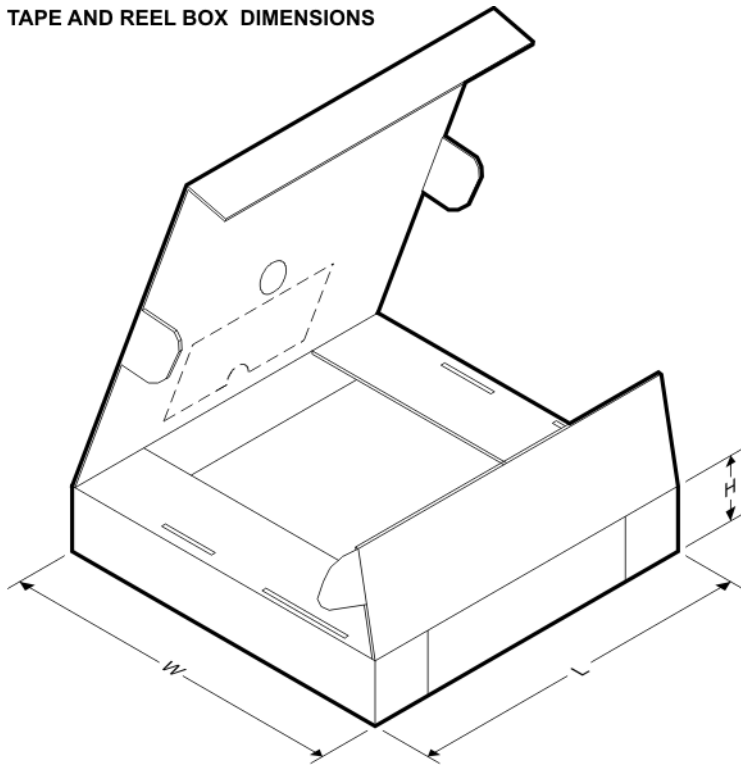

*All dimensions are nominal

Device	Package Type	Package Drawing	Pins	SPQ	Length (mm)	Width (mm)	Height (mm)
SN65LVDM1676DGGR	TSSOP	DGG	64	2000	346.0	346.0	41.0
SN65LVDM1677DGGR	TSSOP	DGG	64	2000	346.0	346.0	41.0

DGG (R-PDSO-G**)

PLASTIC SMALL-OUTLINE PACKAGE

48 PINS SHOWN

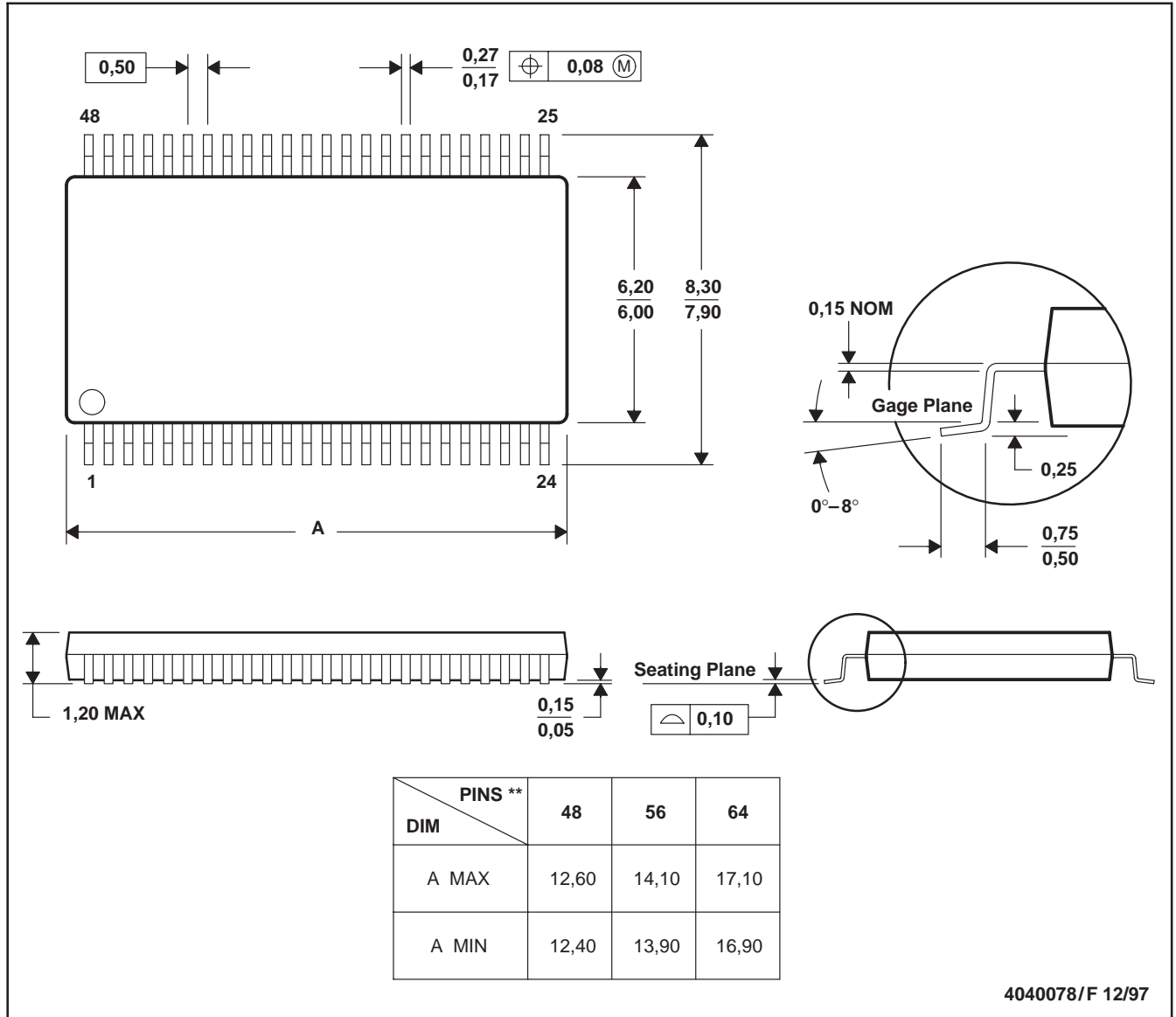

- NOTES: A. All linear dimensions are in millimeters.
 B. This drawing is subject to change without notice.
 C. Body dimensions do not include mold protrusion not to exceed 0,15.
 D. Falls within JEDEC MO-153

IMPORTANT NOTICE

Texas Instruments Incorporated and its subsidiaries (TI) reserve the right to make corrections, modifications, enhancements, improvements, and other changes to its products and services at any time and to discontinue any product or service without notice. Customers should obtain the latest relevant information before placing orders and should verify that such information is current and complete. All products are sold subject to TI's terms and conditions of sale supplied at the time of order acknowledgment.

TI warrants performance of its hardware products to the specifications applicable at the time of sale in accordance with TI's standard warranty. Testing and other quality control techniques are used to the extent TI deems necessary to support this warranty. Except where mandated by government requirements, testing of all parameters of each product is not necessarily performed.

TI assumes no liability for applications assistance or customer product design. Customers are responsible for their products and applications using TI components. To minimize the risks associated with customer products and applications, customers should provide adequate design and operating safeguards.

TI does not warrant or represent that any license, either express or implied, is granted under any TI patent right, copyright, mask work right, or other TI intellectual property right relating to any combination, machine, or process in which TI products or services are used. Information published by TI regarding third-party products or services does not constitute a license from TI to use such products or services or a warranty or endorsement thereof. Use of such information may require a license from a third party under the patents or other intellectual property of the third party, or a license from TI under the patents or other intellectual property of TI.

Reproduction of TI information in TI data books or data sheets is permissible only if reproduction is without alteration and is accompanied by all associated warranties, conditions, limitations, and notices. Reproduction of this information with alteration is an unfair and deceptive business practice. TI is not responsible or liable for such altered documentation. Information of third parties may be subject to additional restrictions.

Resale of TI products or services with statements different from or beyond the parameters stated by TI for that product or service voids all express and any implied warranties for the associated TI product or service and is an unfair and deceptive business practice. TI is not responsible or liable for any such statements.

TI products are not authorized for use in safety-critical applications (such as life support) where a failure of the TI product would reasonably be expected to cause severe personal injury or death, unless officers of the parties have executed an agreement specifically governing such use. Buyers represent that they have all necessary expertise in the safety and regulatory ramifications of their applications, and acknowledge and agree that they are solely responsible for all legal, regulatory and safety-related requirements concerning their products and any use of TI products in such safety-critical applications, notwithstanding any applications-related information or support that may be provided by TI. Further, Buyers must fully indemnify TI and its representatives against any damages arising out of the use of TI products in such safety-critical applications.

TI products are neither designed nor intended for use in military/aerospace applications or environments unless the TI products are specifically designated by TI as military-grade or "enhanced plastic." Only products designated by TI as military-grade meet military specifications. Buyers acknowledge and agree that any such use of TI products which TI has not designated as military-grade is solely at the Buyer's risk, and that they are solely responsible for compliance with all legal and regulatory requirements in connection with such use.

TI products are neither designed nor intended for use in automotive applications or environments unless the specific TI products are designated by TI as compliant with ISO/TS 16949 requirements. Buyers acknowledge and agree that, if they use any non-designated products in automotive applications, TI will not be responsible for any failure to meet such requirements.

Following are URLs where you can obtain information on other Texas Instruments products and application solutions:

Products

Amplifiers	amplifier.ti.com
Data Converters	dataconverter.ti.com
DSP	dsp.ti.com
Clocks and Timers	www.ti.com/clocks
Interface	interface.ti.com
Logic	logic.ti.com
Power Mgmt	power.ti.com
Microcontrollers	microcontroller.ti.com
RFID	www.ti-rfid.com
RF/IF and ZigBee® Solutions	www.ti.com/lprf

Applications

Audio	www.ti.com/audio
Automotive	www.ti.com/automotive
Broadband	www.ti.com/broadband
Digital Control	www.ti.com/digitalcontrol
Medical	www.ti.com/medical
Military	www.ti.com/military
Optical Networking	www.ti.com/opticalnetwork
Security	www.ti.com/security
Telephony	www.ti.com/telephony
Video & Imaging	www.ti.com/video
Wireless	www.ti.com/wireless

Mailing Address: Texas Instruments, Post Office Box 655303, Dallas, Texas 75265
Copyright © 2008, Texas Instruments Incorporated