

DUAL MULTIPLEXED LVDS REPEATERS

FEATURES

- Meets or Exceeds the Requirements of ANSI TIA/EIA-644-1995 Standard
- Designed for Clock Rates up to 200 MHz (400 Mbps)
- Designed for Data Rates up to 250 Mbps
- Pin Compatible With SN65LVDS122 and SN65LVDT122, 1.5 Gbps 2x2 Crosspoint Switch From TI
- ESD Protection Exceeds 12 kV on Bus Pins
- Operates From a Single 3.3-V Supply
- Low-Voltage Differential Signaling With Output Voltages of 350 mV Into:
 - 100-Ω Load (SN65LVDS22)
 - 50-Ω Load (SN65LVDM22)
- Propagation Delay Time; 4 ns Typ
- Power Dissipation at 400 Mbps of 150 mW
- Bus Pins Are High Impedance When Disabled or With V_{CC} Less Than 1.5 V
- LVTTTL Levels Are 5 V Tolerant
- Open-Circuit Fail Safe Receiver

DESCRIPTION

The SN65LVDS22 and SN65LVDM22 are differential line drivers and receivers that use low-voltage differential signaling (LVDS) to achieve signaling rates as high as 400 Mbps. The receiver outputs can be switched to either or both drivers through the multiplexer control signals S0 and S1. This allows the flexibility to perform splitter or signal routing functions with a single device.

The TIA/EIA-644 standard compliant electrical interface provides a minimum differential output voltage magnitude of 247 mV into a 100-Ω load and receipt of 100 mV signals with up to 1 V of ground potential difference between a transmitter and receiver. The SN65LVDM22 doubles the output drive current to achieve LVDS levels with a 50-Ω load.

SN65LVDS22D and SN65LVDS22PW (Marked as LVDS22)
SN65LVDM22D and SN65LVDM22PW (Marked as LVDM22)

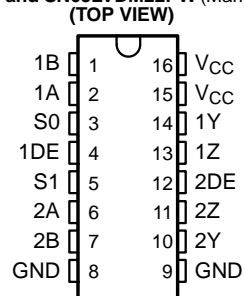

logic diagram (positive logic)

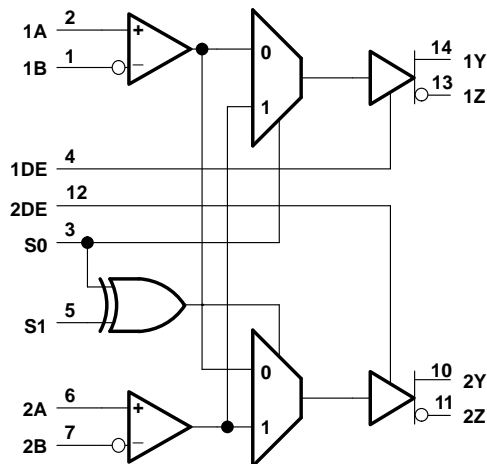

MUX TRUTH TABLE

INPUT		OUTPUT		FUNCTION
S1	S0	1Y/1Z	2Y/2Z	
0	0	1A/1B	1A/1B	Splitter
0	1	2A/2B	2A/2B	Splitter
1	0	1A/1B	2A/2B	Router
1	1	2A/2B	1A/1B	Router



Please be aware that an important notice concerning availability, standard warranty, and use in critical applications of Texas Instruments semiconductor products and disclaimers thereto appears at the end of this data sheet.

SN65LVDS22 SN65LVDM22

SLLS315C–DECEMBER 1998–REVISED JUNE 2002

The intended application of these devices and signaling technique is for both point-to-point baseband (single termination) and multipoint (double termination) data transmissions over controlled impedance media. The transmission media may be printed-circuit board traces, backplanes, or cables. (Note: The ultimate rate and distance of data transfer is dependent upon the attenuation characteristics of the media, the noise coupling to the environment, and other application specific characteristics).

The SN65LVDS22 and SN65LVDM22 are characterized for operation from -40°C to 85°C .



These devices have limited built-in ESD protection. The leads should be shorted together or the device placed in conductive foam during storage or handling to prevent electrostatic damage to the MOS gates.

EQUIVALENT INPUT AND OUTPUT SCHEMATIC DIAGRAMS

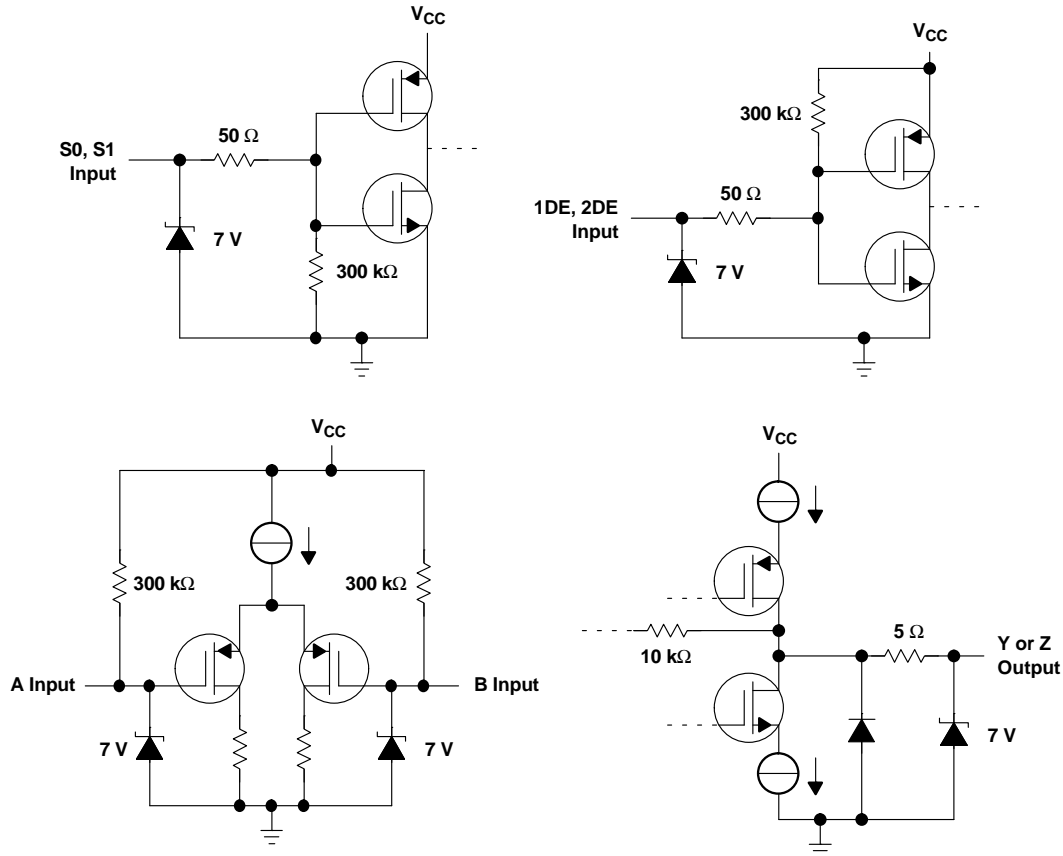

ABSOLUTE MAXIMUM RATINGS

over operating free-air temperature range (unless otherwise noted)⁽¹⁾

		UNIT
Supply voltage range, V_{CC} (see Note ⁽²⁾)		-0.5 V to 4 V
Voltage range	(DE, S0, S1)	-0.5 V to 6 V
	(Y, Z, A, and B)	-0.5 V to 4 V
Electrostatic discharge	A, B, Y, Z and GND (see Note ⁽³⁾)	Class 3, A:12 kV, B:600 V
	All pins	Class 3, A:5 kV, B:500 V
Continuous power dissipation		See Dissipation Rating Table
Storage temperature range		-65°C to 150°C
Lead temperature 1,6 mm (1/16 inch) from case for 10 seconds		260°C

(1) Stresses beyond those listed under *absolute maximum ratings* may cause permanent damage to the device. These are stress ratings only, and functional operation of the device at these or any other conditions beyond those indicated under *recommended operating conditions* is not implied. Exposure to absolute-maximum-rated conditions for extended periods may affect device reliability.

(2) All voltage values, except differential I/O bus voltages, are with respect to network ground terminal.

(3) Tested in accordance with MIL-STD-883C Method 3015.7.

DISSIPATION RATING TABLE

PACKAGE	$T_A \leq 25^\circ\text{C}$ POWER RATING	DERATING FACTOR ⁽¹⁾ ABOVE $T_A = 25^\circ\text{C}$	$T_A = 85^\circ\text{C}$ POWER RATING
D	1110 mW	8.9 mW/°C	577 mW
PW	839 mW	6.7 mW/°C	437 mW

(1) This is the inverse of the junction-to-ambient thermal resistance when board-mounted and with no air flow.

RECOMMENDED OPERATING CONDITIONS

		MIN	NOM	MAX	UNIT
V_{CC}	Supply voltage	3	3.3	3.6	V
V_{IH}	High-level input voltage	S0, S1, 1DE, 2DE		2	V
V_{IL}	Low-level input voltage	S0, S1, 1DE, 2DE		0.8	V
$ V_{ID} $	Magnitude of differential input voltage	0.1		0.6	V
V_{IC}	Common-mode input voltage (see Figure 1)	$\frac{ V_{ID} }{2}$		$2.4 - \frac{ V_{ID} }{2}$	V
				$V_{CC} - 0.8$	V
T_A	Operating free-air temperature	40		85	°C

TIMING REQUIREMENTS

PARAMETER		MIN	NOM	MAX	UNIT
t_{su}	Input to select setup time		1.6		ns
t_h	Input to select hold time		1		ns
t_{switch}	Select to switch output		3.2	5	ns

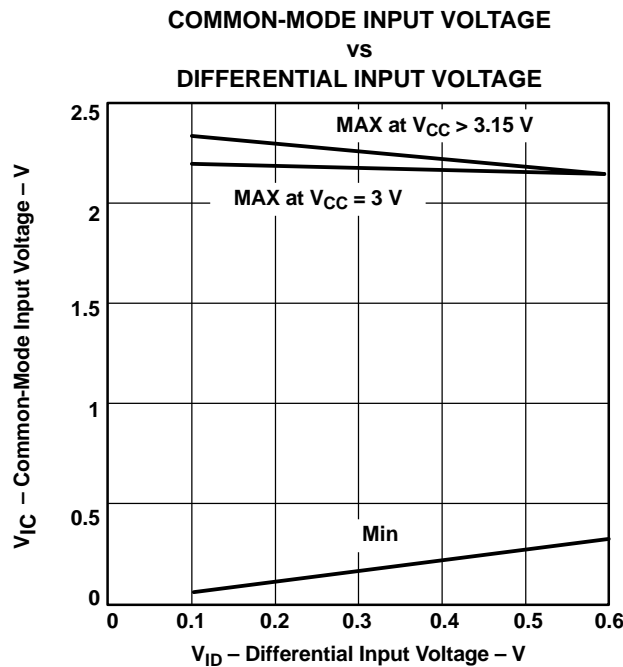

Figure 1. Common-Mode Input Voltage vs Differential Input Voltage

RECEIVER ELECTRICAL CHARACTERISTICS

over recommended operating conditions (unless otherwise noted)

PARAMETER		TEST CONDITIONS	MIN	TYP	MAX	UNIT
V_{IT+}	Positive-going differential input voltage threshold				100	mV
V_{IT-}	Negative-going differential input voltage threshold		100			mV
I_i	Input current (A or B inputs)	$V_I = 0\text{ V}$	2		20	μA
		$V_I = 2.4\text{ V}$	1.2			
$I_{i(OFF)}$	Power-off input current (A or B inputs)	$V_{CC} = 0\text{ V}$			20	μA

RECEIVER/DRIVER ELECTRICAL CHARACTERISTICS

over recommended operating conditions (unless otherwise noted)

PARAMETER		TEST CONDITIONS	MIN	TYP ⁽¹⁾	MAX	UNIT
V_{OD}	Differential output voltage magnitude	See Figure 2	247	340	454	mV
ΔV_{OD}	Change in differential output voltage magnitude between logic states		-50		50	mV
$V_{OC(SS)}$	Steady-state common-mode output voltage	$R_L = 100\ \Omega$ ('LVDS22), $R_L = 50\ \Omega$ ('LVDM22) See Figure 3	1.125		1.375	V
$\Delta V_{OC(SS)}$	Change in steady-state common-mode output voltage between logic states		-50	3	50	mV
$V_{OC(PP)}$	Peak-to-peak common-mode output voltage				150	mV
I_{CC}	Supply current	No Load		8	12	mA
		$R_L = 100\ \Omega$ ('LVDS22)		13	20	
		$R_L = 50\ \Omega$ ('LVDM22)		21	27	
		Disabled		3	6	
I_{IH}	High-level input current	DE	$V_{IH} = 5\text{ V}$		-10	μA
		S0, S1			20	
I_{IL}	Low-level input current	DE	$V_{IL} = 0.8\text{ V}$		-10	μA
		S0, S1			10	
I_{OS}	Short-circuit output current	V_{OY} or $V_{OZ} = 0\text{ V}$, $V_{OD} = 0\text{ V}$ ('LVDS22)			-10	mA
		V_{OY} or $V_{OZ} = 0\text{ V}$, $V_{OD} = 0\text{ V}$ ('LVDM22)			-10	
		V_{OY} or $V_{OZ} = 0\text{ V}$, $V_{OD} = 0\text{ V}$ ('LVDM22)			-10	
I_{OZ}	High-impedance output current	$V_{OD} = 600\text{ mV}$		0.015	± 1	μA
		$V_O = 0\text{ V}$ or V_{CC}		0.015	± 1	
$I_{O(OFF)}$	Power-off output current	$V_{CC} = 0\text{ V}$, $V_O = 3.6\text{ V}$		0.015	± 1	μA
C_{IN}	Input capacitance			3		pF

(1) All typical values are at 25°C and with a 3.3-V supply.

DIFFERENTIAL RECEIVER TO DRIVER SWITCHING CHARACTERISTICS

over recommended operating conditions (unless otherwise noted)

PARAMETER		TEST CONDITIONS	MIN	TYP ⁽¹⁾	MAX	UNIT	
t_{PLH}	Differential propagation delay time, low-to-high	$C_L = 10$ pF, See Figure 4		4	6	ns	
t_{PHL}	Differential propagation delay time, high-to-low			4	6	ns	
$t_{sk(p)}$	Pulse skew ($ t_{PHL} - t_{PLH} $)			0.2		ns	
t_r	Transition time, low-to-high		SN65LVDS22		1	1.5	ns
t_f	Transition time, low-to-high		SN65LVDM22		0.8	1.3	ns
t_f	Transition time, high-to-low		SN65LVDS22		1	1.5	ns
t_f	Transition time, high-to-low		SN65LVDM22		0.8	1.3	ns
t_{PHZ}	Propagation delay time, high-level-to-high-impedance output		See Figure 5		4	10	ns
t_{PLZ}	Propagation delay time, low-level-to-high-impedance output			5	10	ns	
t_{PZH}	Propagation delay time, high-impedance-to-high-level output			5	10	ns	
t_{PZL}	Propagation delay time, high-impedance-to-low-level output			6	10	ns	
$t_{PHL_R1_Dx}$	Channel-to-channel skew, receiver to driver ⁽²⁾			0.2		ns	
$t_{PLH_R1_Dx}$				0.2			
$t_{PHL_R2_Dx}$				0.2			
$t_{PLH_R2_Dx}$				0.2			
f_{max}	Maximum operating frequency	All channels switching		200		MHz	

(1) All typical values are at 25°C and with a 3.3-V supply.

(2) These parametric values are measured over supply voltage and temperature ranges recommended for the device.

PARAMETER MEASUREMENT INFORMATION

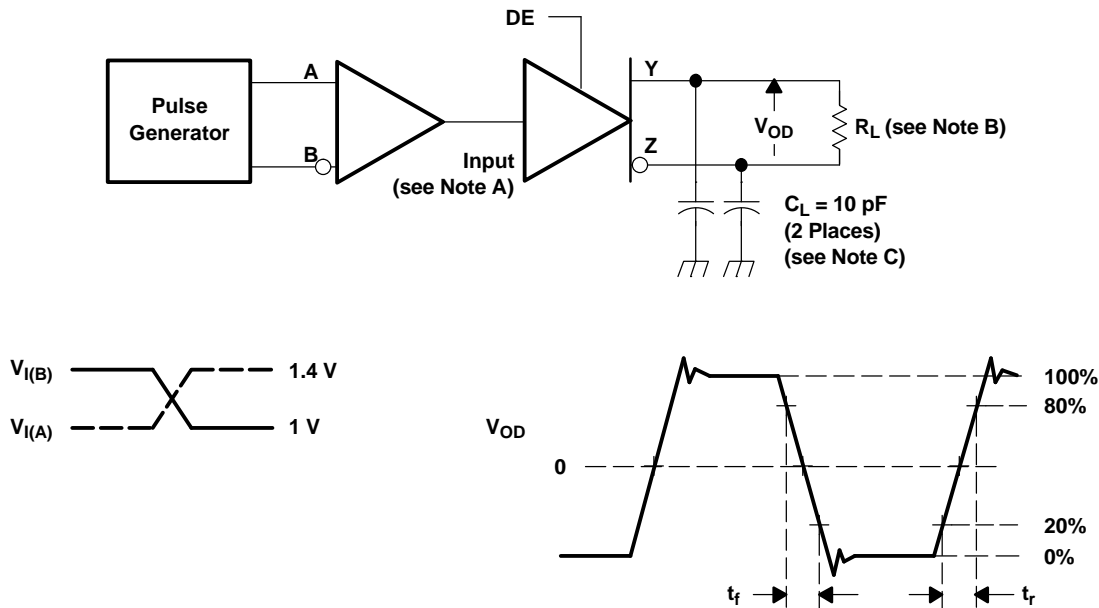

- All input pulses are supplied by a generator having the following characteristics: t_r or $t_f \leq 1$ ns, pulse repetition rate (PRR) = 50 Mpps, pulse width = 10 ± 0.2 ns.
- $R_L = 100 \Omega$ or $50 \Omega \pm 1\%$
- C_L includes instrumentation and fixture capacitance within 6 mm of the D.U.T.

Figure 2. Test Circuit and Voltage Definitions for the Differential Output Signal

PARAMETER MEASUREMENT INFORMATION (continued)

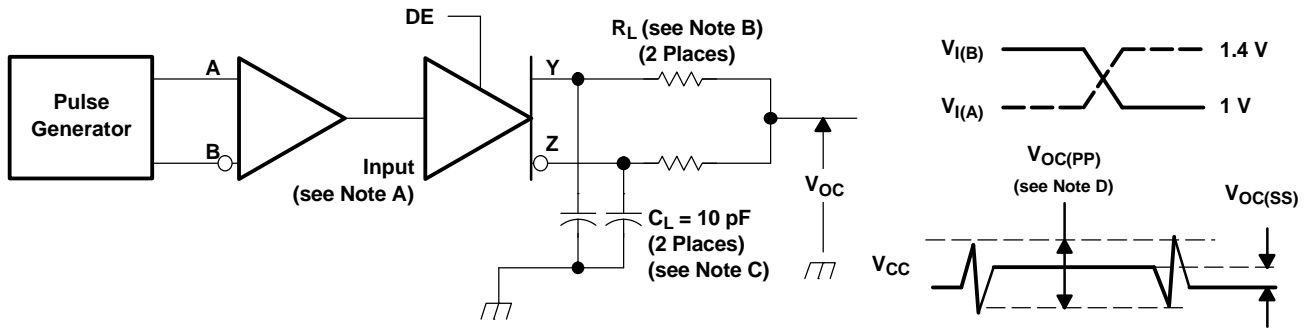

- A. All input pulses are supplied by a generator having the following characteristics: t_r or $t_f \leq 1$ ns, pulse repetition rate (PRR) = 50 Mpps, pulse width = 10 ± 0.2 ns.
- B. $R_L = 100 \Omega$ or $50 \Omega \pm 1\%$
- C. C_L includes instrumentation and fixture capacitance within 6 mm of the D.U.T.
- D. The measurement of $V_{OC(PP)}$ is made on test equipment with a -3 dB bandwidth of at least 300 MHz.

Figure 3. Test Circuit and Definitions for the Driver Common-Mode Output Voltage

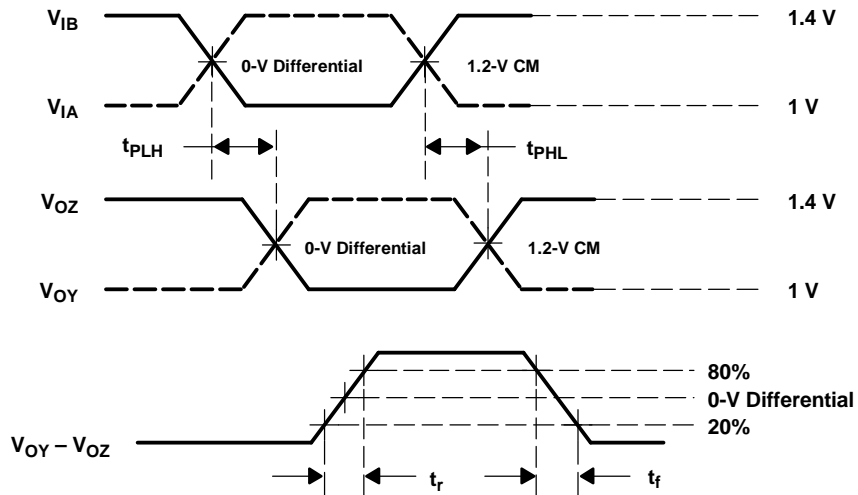
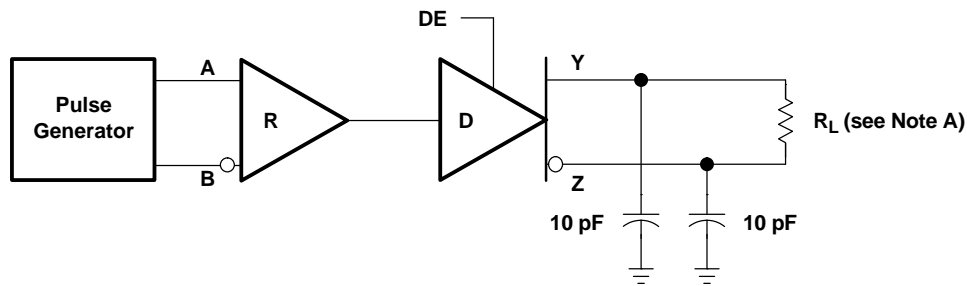

- A. $R_L = 100 \Omega$ or $50 \Omega \pm 1\%$
- B. All input pulses are supplied by a generator having the following characteristics: pulse repetition rate (PRR) = 50 Mpps, pulse width = 10 ± 0.2 ns.

Figure 4. Differential Receiver to Driver Propagation Delay and Driver Transition Time Waveforms

PARAMETER MEASUREMENT INFORMATION (continued)

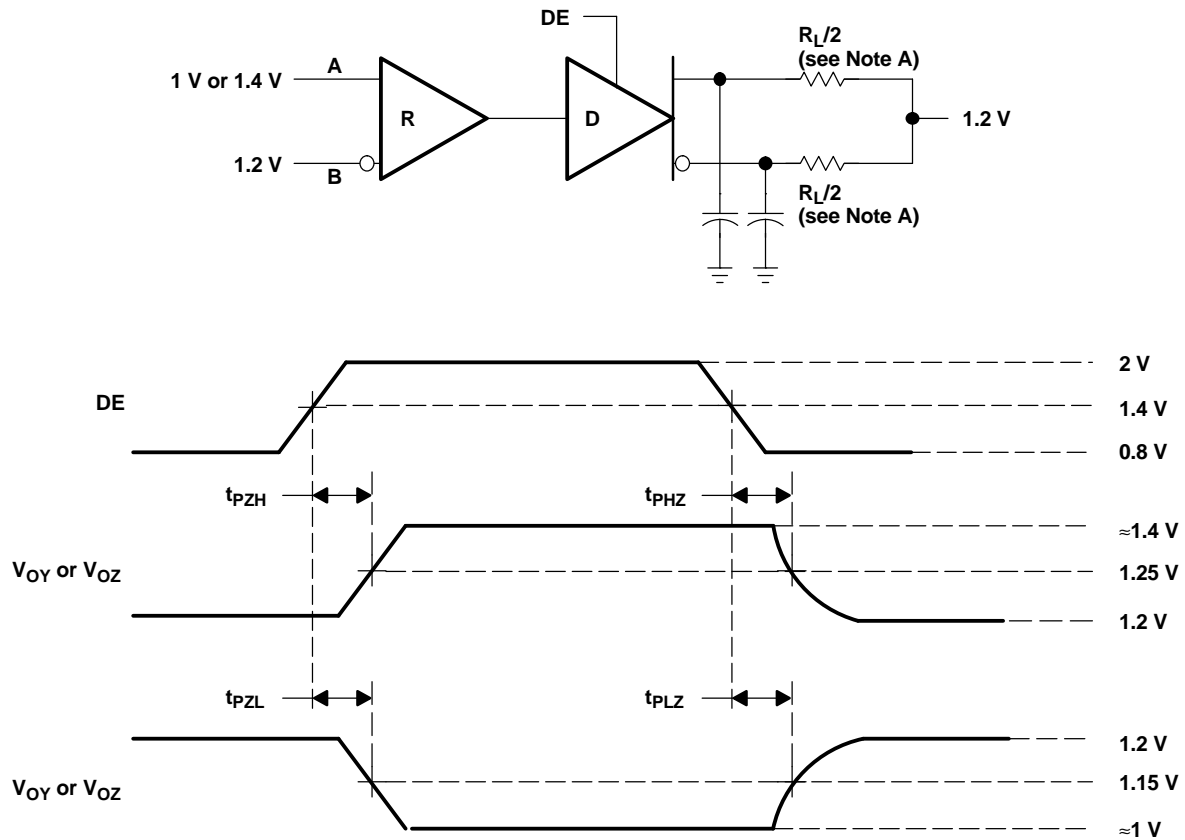

- A. $R_L = 100 \Omega$ or $50 \Omega \pm 1\%$
- B. All input pulses are supplied by a generator having the following characteristics: pulse repetition rate (PRR) = 0.5 Mpps, pulse width = 500 ± 10 ns.

Figure 5. Enable and Disable Timing Circuit

PARAMETER MEASUREMENT INFORMATION (continued)

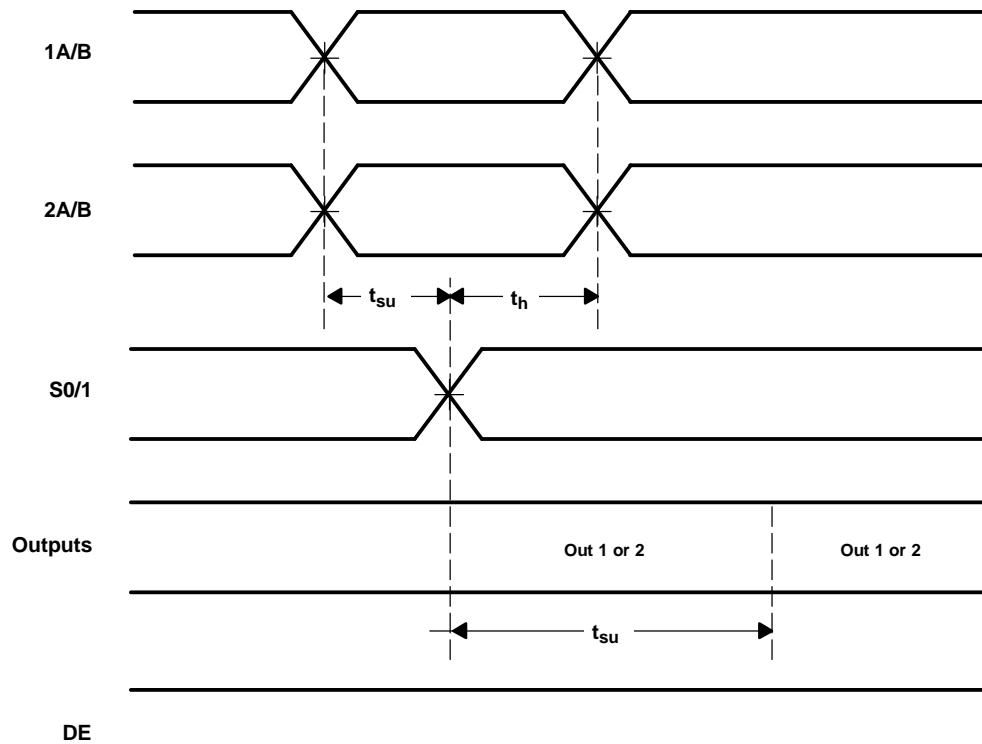

NOTE: t_{su} and t_h times specify that data must be in a stable state before and after MUX control switches.

Figure 6. Input-to-Select for Both Rising and Falling Edge Setup and Hold Times

TYPICAL CHARACTERISTICS

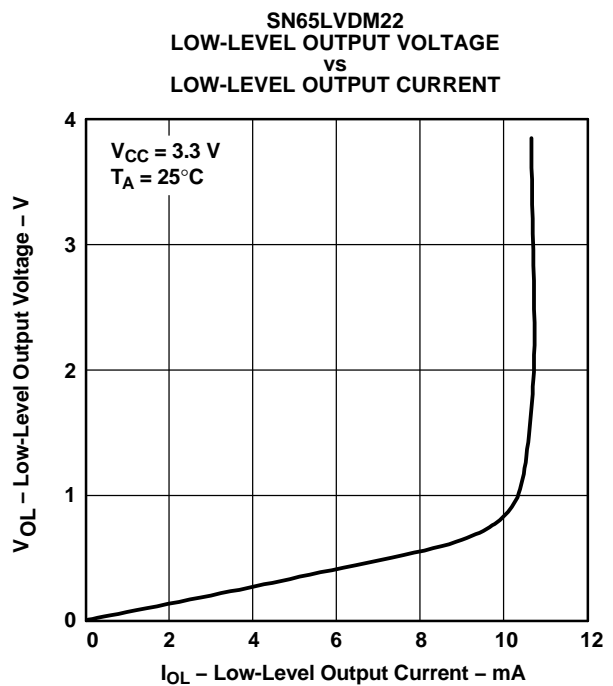
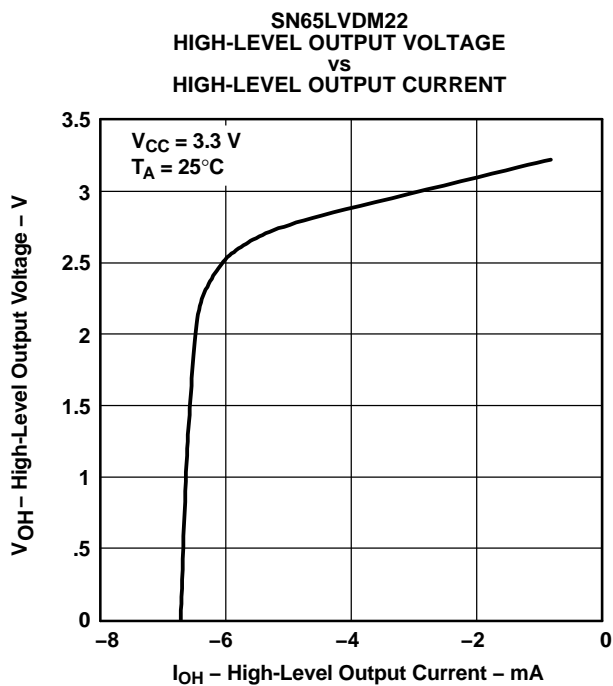
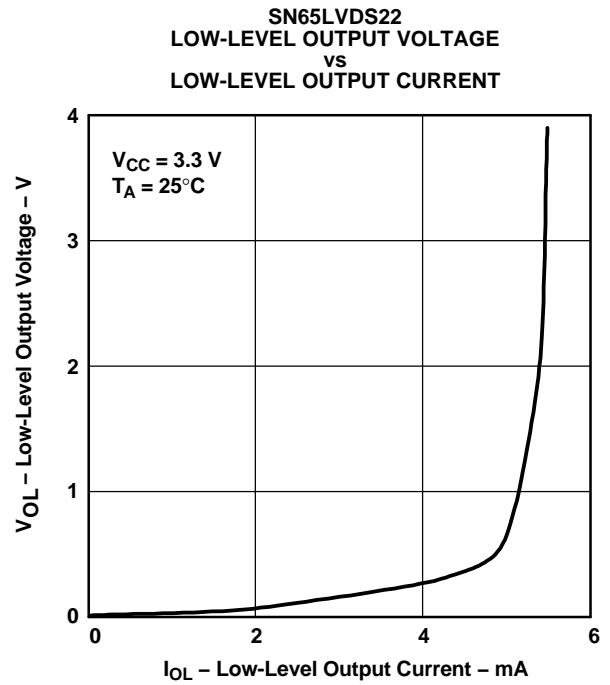
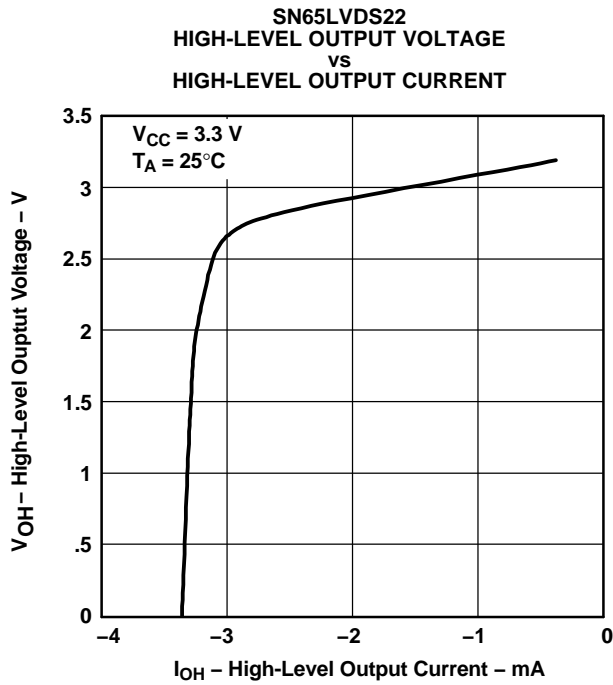

APPLICATION INFORMATION

FAIL SAFE

One of the most common problems with differential signaling applications is how the system responds when no differential voltage is present on the signal pair. The LVDS receiver is like most differential line receivers, in that its output logic state can be indeterminate when the differential input voltage is between -100 mV and 100 mV and within its recommended input common-mode voltage range. However, TI's LVDS receiver is different in how it handles the open-input circuit situation.

Open-circuit means that there is little or no input current to the receiver from the data line itself. This could be when the driver is in a high-impedance state or the cable is disconnected. When this occurs, the LVDS receiver pulls each line of the signal pair to near V_{CC} through $300\text{-k}\Omega$ resistors as shown in [Figure 11](#). The fail-safe feature uses an AND gate with input voltage thresholds at about 2.3 V to detect this condition and force the output to a high-level regardless of the differential input voltage.

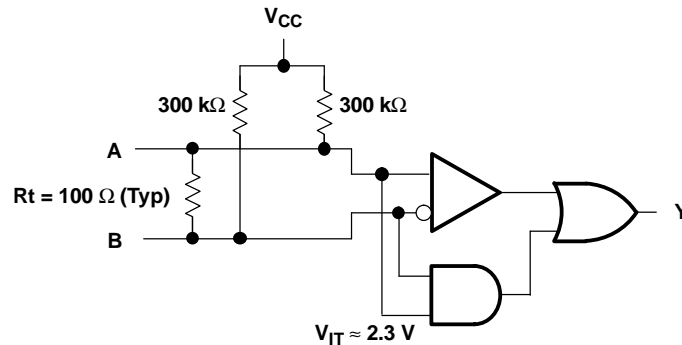

Figure 11. Open-Circuit Fail Safe of the LVDS Receiver

It is only under these conditions that the output of the receiver is valid with less than a 100 mV differential input voltage magnitude. The presence of the termination resistor, R_t , does not affect the fail-safe function as long as it is connected as shown in [Figure 11](#). Other termination circuits may allow a dc current to ground that could defeat the pullup currents from the receiver and the fail-safe feature.

PACKAGING INFORMATION

Orderable Device	Status ⁽¹⁾	Package Type	Package Drawing	Pins	Package Qty	Eco Plan ⁽²⁾	Lead/Ball Finish	MSL Peak Temp ⁽³⁾
SN65LVDM22D	ACTIVE	SOIC	D	16	40	Green (RoHS & no Sb/Br)	CU NIPDAU	Level-1-260C-UNLIM
SN65LVDM22DG4	ACTIVE	SOIC	D	16	40	Green (RoHS & no Sb/Br)	CU NIPDAU	Level-1-260C-UNLIM
SN65LVDM22PW	ACTIVE	TSSOP	PW	16	90	Green (RoHS & no Sb/Br)	CU NIPDAU	Level-1-260C-UNLIM
SN65LVDM22PWG4	ACTIVE	TSSOP	PW	16	90	Green (RoHS & no Sb/Br)	CU NIPDAU	Level-1-260C-UNLIM
SN65LVDS22D	ACTIVE	SOIC	D	16	40	Green (RoHS & no Sb/Br)	CU NIPDAU	Level-1-260C-UNLIM
SN65LVDS22DG4	ACTIVE	SOIC	D	16	40	Green (RoHS & no Sb/Br)	CU NIPDAU	Level-1-260C-UNLIM
SN65LVDS22DR	ACTIVE	SOIC	D	16	2500	Green (RoHS & no Sb/Br)	CU NIPDAU	Level-1-260C-UNLIM
SN65LVDS22DRG4	ACTIVE	SOIC	D	16	2500	Green (RoHS & no Sb/Br)	CU NIPDAU	Level-1-260C-UNLIM
SN65LVDS22PW	ACTIVE	TSSOP	PW	16	90	Green (RoHS & no Sb/Br)	CU NIPDAU	Level-1-260C-UNLIM
SN65LVDS22PWG4	ACTIVE	TSSOP	PW	16	90	Green (RoHS & no Sb/Br)	CU NIPDAU	Level-1-260C-UNLIM
SN65LVDS22PWR	ACTIVE	TSSOP	PW	16	2000	Green (RoHS & no Sb/Br)	CU NIPDAU	Level-1-260C-UNLIM
SN65LVDS22PWRG4	ACTIVE	TSSOP	PW	16	2000	Green (RoHS & no Sb/Br)	CU NIPDAU	Level-1-260C-UNLIM

⁽¹⁾ The marketing status values are defined as follows:

ACTIVE: Product device recommended for new designs.

LIFEBUY: TI has announced that the device will be discontinued, and a lifetime-buy period is in effect.

NRND: Not recommended for new designs. Device is in production to support existing customers, but TI does not recommend using this part in a new design.

PREVIEW: Device has been announced but is not in production. Samples may or may not be available.

OBSOLETE: TI has discontinued the production of the device.

⁽²⁾ Eco Plan - The planned eco-friendly classification: Pb-Free (RoHS), Pb-Free (RoHS Exempt), or Green (RoHS & no Sb/Br) - please check <http://www.ti.com/productcontent> for the latest availability information and additional product content details.

TBD: The Pb-Free/Green conversion plan has not been defined.

Pb-Free (RoHS): TI's terms "Lead-Free" or "Pb-Free" mean semiconductor products that are compatible with the current RoHS requirements for all 6 substances, including the requirement that lead not exceed 0.1% by weight in homogeneous materials. Where designed to be soldered at high temperatures, TI Pb-Free products are suitable for use in specified lead-free processes.

Pb-Free (RoHS Exempt): This component has a RoHS exemption for either 1) lead-based flip-chip solder bumps used between the die and package, or 2) lead-based die adhesive used between the die and leadframe. The component is otherwise considered Pb-Free (RoHS compatible) as defined above.

Green (RoHS & no Sb/Br): TI defines "Green" to mean Pb-Free (RoHS compatible), and free of Bromine (Br) and Antimony (Sb) based flame retardants (Br or Sb do not exceed 0.1% by weight in homogeneous material)

⁽³⁾ MSL, Peak Temp. -- The Moisture Sensitivity Level rating according to the JEDEC industry standard classifications, and peak solder temperature.

Important Information and Disclaimer: The information provided on this page represents TI's knowledge and belief as of the date that it is provided. TI bases its knowledge and belief on information provided by third parties, and makes no representation or warranty as to the accuracy of such information. Efforts are underway to better integrate information from third parties. TI has taken and continues to take reasonable steps to provide representative and accurate information but may not have conducted destructive testing or chemical analysis on incoming materials and chemicals. TI and TI suppliers consider certain information to be proprietary, and thus CAS numbers and other limited information may not be available for release.

In no event shall TI's liability arising out of such information exceed the total purchase price of the TI part(s) at issue in this document sold by TI to Customer on an annual basis.

TAPE AND REEL INFORMATION



QUADRANT ASSIGNMENTS FOR PIN 1 ORIENTATION IN TAPE



*All dimensions are nominal

Device	Package Type	Package Drawing	Pins	SPQ	Reel Diameter (mm)	Reel Width W1 (mm)	A0 (mm)	B0 (mm)	K0 (mm)	P1 (mm)	W (mm)	Pin1 Quadrant
SN65LVDS22DR	SOIC	D	16	2500	330.0	16.4	6.5	10.3	2.1	8.0	16.0	Q1
SN65LVDS22PWR	TSSOP	PW	16	2000	330.0	12.4	6.9	5.6	1.6	8.0	12.0	Q1

TAPE AND REEL BOX DIMENSIONS

*All dimensions are nominal

Device	Package Type	Package Drawing	Pins	SPQ	Length (mm)	Width (mm)	Height (mm)
SN65LVDS22DR	SOIC	D	16	2500	346.0	346.0	33.0
SN65LVDS22PWR	TSSOP	PW	16	2000	346.0	346.0	29.0

IMPORTANT NOTICE

Texas Instruments Incorporated and its subsidiaries (TI) reserve the right to make corrections, modifications, enhancements, improvements, and other changes to its products and services at any time and to discontinue any product or service without notice. Customers should obtain the latest relevant information before placing orders and should verify that such information is current and complete. All products are sold subject to TI's terms and conditions of sale supplied at the time of order acknowledgment.

TI warrants performance of its hardware products to the specifications applicable at the time of sale in accordance with TI's standard warranty. Testing and other quality control techniques are used to the extent TI deems necessary to support this warranty. Except where mandated by government requirements, testing of all parameters of each product is not necessarily performed.

TI assumes no liability for applications assistance or customer product design. Customers are responsible for their products and applications using TI components. To minimize the risks associated with customer products and applications, customers should provide adequate design and operating safeguards.

TI does not warrant or represent that any license, either express or implied, is granted under any TI patent right, copyright, mask work right, or other TI intellectual property right relating to any combination, machine, or process in which TI products or services are used. Information published by TI regarding third-party products or services does not constitute a license from TI to use such products or services or a warranty or endorsement thereof. Use of such information may require a license from a third party under the patents or other intellectual property of the third party, or a license from TI under the patents or other intellectual property of TI.

Reproduction of TI information in TI data books or data sheets is permissible only if reproduction is without alteration and is accompanied by all associated warranties, conditions, limitations, and notices. Reproduction of this information with alteration is an unfair and deceptive business practice. TI is not responsible or liable for such altered documentation. Information of third parties may be subject to additional restrictions.

Resale of TI products or services with statements different from or beyond the parameters stated by TI for that product or service voids all express and any implied warranties for the associated TI product or service and is an unfair and deceptive business practice. TI is not responsible or liable for any such statements.

TI products are not authorized for use in safety-critical applications (such as life support) where a failure of the TI product would reasonably be expected to cause severe personal injury or death, unless officers of the parties have executed an agreement specifically governing such use. Buyers represent that they have all necessary expertise in the safety and regulatory ramifications of their applications, and acknowledge and agree that they are solely responsible for all legal, regulatory and safety-related requirements concerning their products and any use of TI products in such safety-critical applications, notwithstanding any applications-related information or support that may be provided by TI. Further, Buyers must fully indemnify TI and its representatives against any damages arising out of the use of TI products in such safety-critical applications.

TI products are neither designed nor intended for use in military/aerospace applications or environments unless the TI products are specifically designated by TI as military-grade or "enhanced plastic." Only products designated by TI as military-grade meet military specifications. Buyers acknowledge and agree that any such use of TI products which TI has not designated as military-grade is solely at the Buyer's risk, and that they are solely responsible for compliance with all legal and regulatory requirements in connection with such use.

TI products are neither designed nor intended for use in automotive applications or environments unless the specific TI products are designated by TI as compliant with ISO/TS 16949 requirements. Buyers acknowledge and agree that, if they use any non-designated products in automotive applications, TI will not be responsible for any failure to meet such requirements.

Following are URLs where you can obtain information on other Texas Instruments products and application solutions:

Products

Amplifiers	amplifier.ti.com
Data Converters	dataconverter.ti.com
DLP® Products	www.dlp.com
DSP	dsp.ti.com
Clocks and Timers	www.ti.com/clocks
Interface	interface.ti.com
Logic	logic.ti.com
Power Mgmt	power.ti.com
Microcontrollers	microcontroller.ti.com
RFID	www.ti-rfid.com
RF/IF and ZigBee® Solutions	www.ti.com/lprf

Applications

Audio	www.ti.com/audio
Automotive	www.ti.com/automotive
Broadband	www.ti.com/broadband
Digital Control	www.ti.com/digitalcontrol
Medical	www.ti.com/medical
Military	www.ti.com/military
Optical Networking	www.ti.com/opticalnetwork
Security	www.ti.com/security
Telephony	www.ti.com/telephony
Video & Imaging	www.ti.com/video
Wireless	www.ti.com/wireless

Mailing Address: Texas Instruments, Post Office Box 655303, Dallas, Texas 75265
Copyright © 2009, Texas Instruments Incorporated