

SN54LS594, SN54LS599, SN74LS594, SN74LS599 8-BIT SHIFT REGISTERS WITH OUTPUT LATCHES

SDLS005 – D2747, JUNE 1983 – REVISED MARCH 1988

- **8-Bit Serial-In, Parallel-Out Shift Registers with Storage**
- **Choice of Output Configurations:**
'LS594 ... Buffered
'LS599 ... Open-Collector
- **Guaranteed Shift Frequency:**
DC to 20 MHz
- **Independent Direct-Overriding Clears on Shift and Storage Registers**
- **Independent Clocks for Both Shift and Storage Registers**

SN54LS594, SN54LS599 . . . J OR W PACKAGE
SN74LS594, SN74LS599 . . . N PACKAGE
(TOP VIEW)

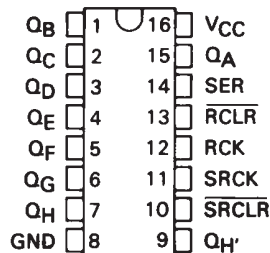

SN54LS594, SN54LS599 . . . FK PACKAGE
(TOP VIEW)

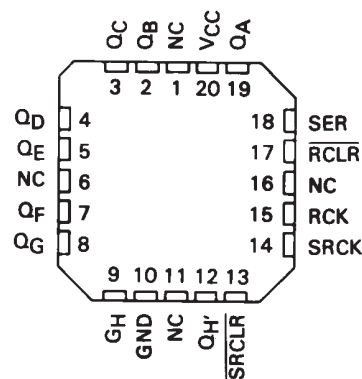

description

These devices each contain an 8-bit D-type storage register. The storage register has buffered ('LS594) or open-collector ('LS599) outputs. Separate clocks and direct-overriding clears are provided on both the shift and storage registers. A shift output (Q_H') is provided for cascading purposes.

Both the shift register and the storage register clocks are positive-edge triggered. If the user wishes to connect both clocks together, the shift register will always be one clock pulse ahead of the storage register.

NC — No internal connection

schematics of inputs and outputs

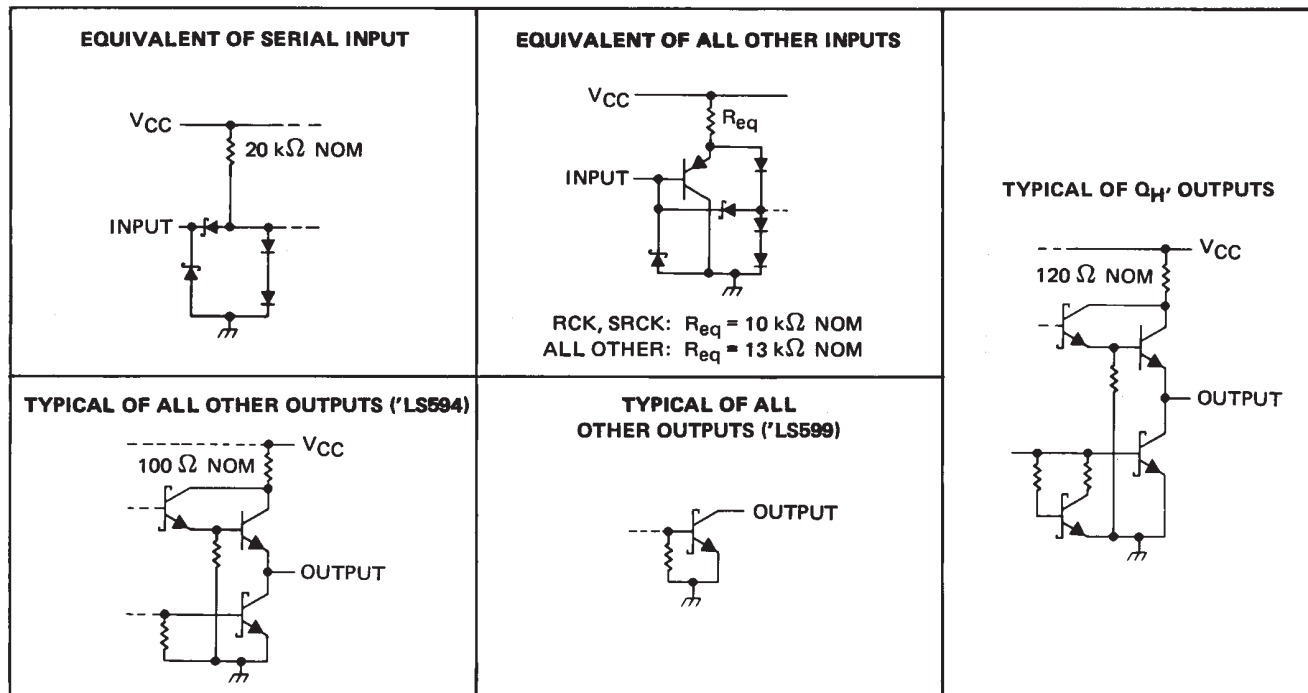

PRODUCTION DATA information is current as of publication date. Products conform to specifications per the terms of Texas Instruments standard warranty. Production processing does not necessarily include testing of all parameters.

**TEXAS
INSTRUMENTS**

POST OFFICE BOX 655303 • DALLAS, TEXAS 75265

Copyright © 1988, Texas Instruments Incorporated

SN54LS594, SN54LS599, SN74LS594, SN74LS599 8-BIT SHIFT REGISTERS WITH OUTPUT LATCHES

SDLS005 – D2747, JUNE 1983 – REVISED MARCH 1988

electrical characteristics over recommended operating free-air temperature range (unless otherwise noted)

PARAMETER	TEST CONDITIONS †	SN54LS'		SN74LS'		UNIT		
		MIN	TYP‡	MAX	MIN		TYP‡	MAX
V _{IK}	V _{CC} = MIN, I _I = -18 mA			-1.5		V		
V _{OH}	'LS594 Q Q _H '	V _{CC} = MIN, V _{IH} = 2 V, V _{IL} = MAX	I _{OH} = -1 mA		2.4 3.2		V	
			I _{OH} = -2.6 mA		2.4 3.1			
			I _{OH} = -1 mA		2.4 3.2			
I _{OH}	'LS599 Q	V _{CC} = MIN, V _{OH} = 5.5 V	V _{IH} = 2 V, V _{IL} = MAX,	0.1		0.1	mA	
V _{OL}	Q Q _H '	V _{CC} = MIN, V _{IL} = MAX	V _{IH} = 2 V,	I _{OL} = 12 mA		0.25 0.4		V
				I _{OL} = 24 mA		0.35 0.5		
				I _{OL} = 8 mA		0.25 0.4		
				I _{OL} = 16 mA		0.35 0.5		
I _I		V _{CC} = MAX, V _I = 7 V			0.1		0.1	mA
I _{IH}		V _{CC} = MAX, V _I = 2.7 V			20		20	μA
I _{IL}	SER	V _{CC} = MAX, V _I = 0.4 V			-0.4		-0.4	mA
	All others				-0.2		-0.2	
I _{OS} §	'LS594 Q	V _{CC} = MAX, V _O = 0			-30 -130		-30 -130	mA
	Q _H '				-20 -100		-20 -100	
I _{CCH}	'LS594	V _{CC} = MAX, All possible inputs grounded,			34 50		34 50	mA
	'LS599				30 45		30 45	
I _{CCL}	'LS594	All outputs open			42 65		42 65	mA
	'LS599				38 55		38 55	

† For conditions shown as MIN or MAX, use the appropriate value specified under recommended operating conditions.

‡ All typical values are at V_{CC} = 5 V, T_A = 25°C.

§ Not more than one output should be shorted at a time, and duration of the short-circuit should not exceed one second.

switching characteristics, V_{CC} = 5 V, T_A = 25°C, (see note 3)

PARAMETER	FROM (INPUT)	TO (OUTPUT)	TEST CONDITIONS	'LS594			'LS599			UNIT
				MIN	TYP	MAX	MIN	TYP	MAX	
t _{PLH}	SRCK↑	Q _H '	R _L = 1 kΩ, C _L = 30 pF	12 18			12 18			ns
t _{PHL}				15 23			17 25			
t _{PLH}	RCK↑	Q _A thru Q _H	R _L = 667 Ω, C _L = 45 pF	12 18			28 42			ns
t _{PHL}				20 30			24 35			
t _{PHL}	SRCLR↓	Q _H '	R _L = 1 kΩ, C _L = 30 pF	22 33			24 35			ns
t _{PHL}	RCLR↓	Q _A thru Q _H	R _L = 667 Ω, C _L = 45 pF	38 57			40 60			ns

NOTE 3: Load circuits and voltage waveforms are shown in Section 1.



POST OFFICE BOX 655303 • DALLAS, TEXAS 75265

SN54LS594, SN54LS599, SN74LS594, SN74LS599 8-BIT SHIFT REGISTERS WITH OUTPUT LATCHES

SDLS005 – D2747, JUNE 1983 – REVISED MARCH 1988

logic symbols†

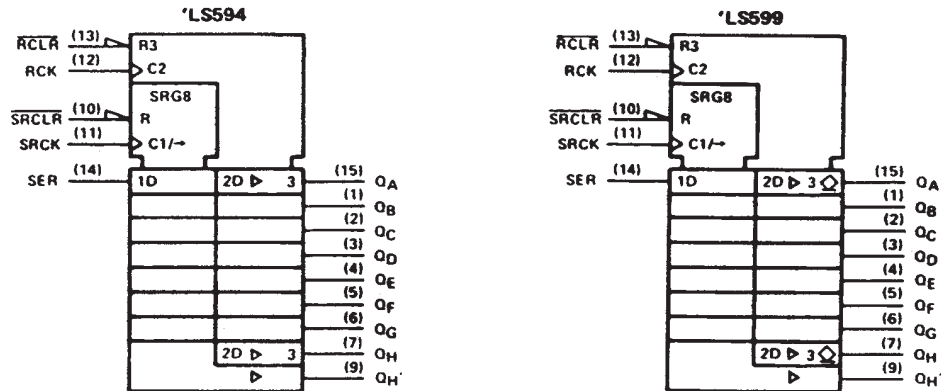

†These symbols are in accordance with ANSI/IEEE Std 91-1984 and IEC Publication 617-12. Pin numbers shown are for J, N, and W packages.

absolute maximum ratings over operating free-air temperature range (unless otherwise noted)

Supply voltage, V_{CC} (see Note 1)	7 V
Input voltage	7 V
Off-state output voltage	5.5 V
Operating free-air temperature range: SN54LS594, SN54LS599	-55°C to 125°C
SN74LS594, SN74LS599	0°C to 70°C
Storage temperature range	-65°C to 150°C

NOTE 1: Voltage values are with respect to the network ground terminal.

recommended operating conditions

		SN54LS'			SN74LS'			UNIT
		MIN	NOM	MAX	MIN	NOM	MAX	
V_{CC}	Supply voltage	4.5	5	5.5	4.75	5	5.25	V
V_{IH}	High-level input voltage	2			2			V
V_{IL}	Low-level input voltage			0.7			0.8	V
V_{OH}	High-level output voltage			5.5			5.5	V
I_{OH}	High-level output current	Q_A thru Q_H , 'LS599 only						mA
		Q_H'			-1		-1	
I_{OL}	Low-level output current	Q_A thru Q_H , 'LS594 only						mA
		Q_H'			-1		-2.6	
I_{OL}	Low-level output current	Q			8		16	mA
					12		24	
f_{SRCK}	Shift clock frequency	0		20	0		20	MHz
f_{RCK}	Register clock frequency	0		25	0		25	MHz
$t_w(SRCK)$	Duration of shift clock pulse	25			25			ns
$t_w(RCK)$	Duration of register clock pulse	20			20			ns
$t_w(SRCLR)$	Duration of shift clear pulse, low level	20			20			ns
$t_w(RCLR)$	Duration of register clear pulse, low level	35			35			ns
t_{su}	Setup time	SRCLR inactive before SRCK↑		20		20		ns
		SER before SRCK↑		20		20		
		SRCK↑ before RCK↑ (see Note 2)		40		40		
		SRCLR low before RCK↑		40		40		
		RCLR high before RCK↑		20		20		
t_h	Hold time	SER after SRCK↑		0		0		ns
T_A	Operating free-air temperature	-55		125	0		70	$^{\circ}\text{C}$

NOTE 2: This setup time ensures the register will see stable data from the shift-register outputs. The clocks may be connected together, in which case the storage register state will be one clock pulse behind the shift register.



POST OFFICE BOX 655303 • DALLAS, TEXAS 75265

TAPE AND REEL INFORMATION

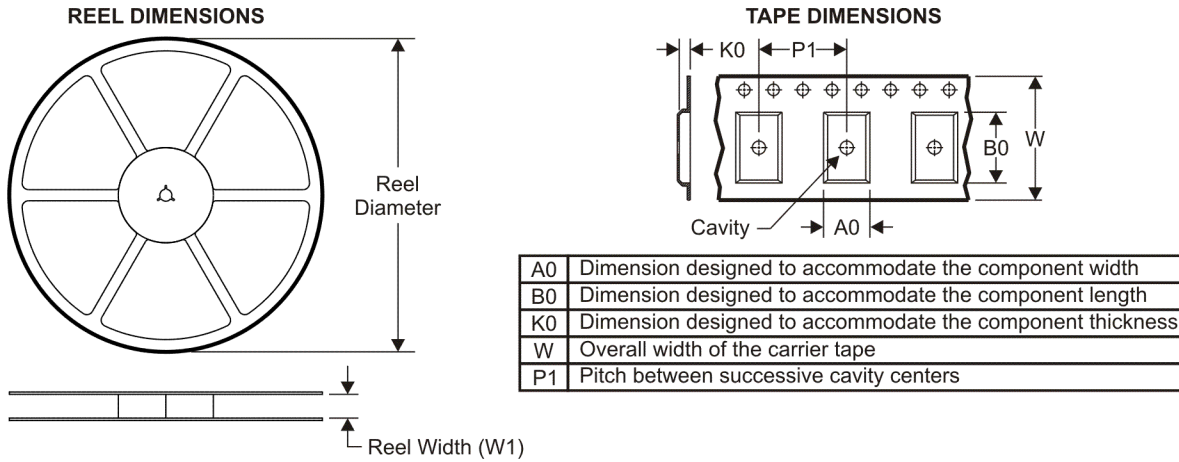

QUADRANT ASSIGNMENTS FOR PIN 1 ORIENTATION IN TAPE

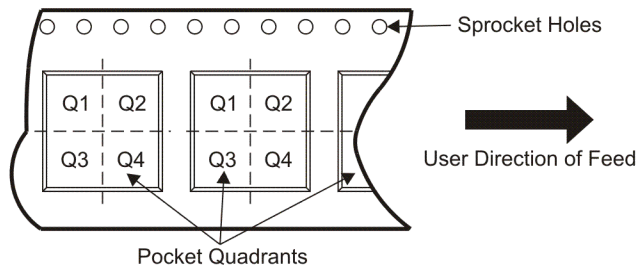

*All dimensions are nominal

Device	Package Type	Package Drawing	Pins	SPQ	Reel Diameter (mm)	Reel Width W1 (mm)	A0 (mm)	B0 (mm)	K0 (mm)	P1 (mm)	W (mm)	Pin1 Quadrant
SN74LS594NSR	SO	NS	16	2000	330.0	16.4	8.2	10.5	2.5	12.0	16.0	Q1

TAPE AND REEL BOX DIMENSIONS

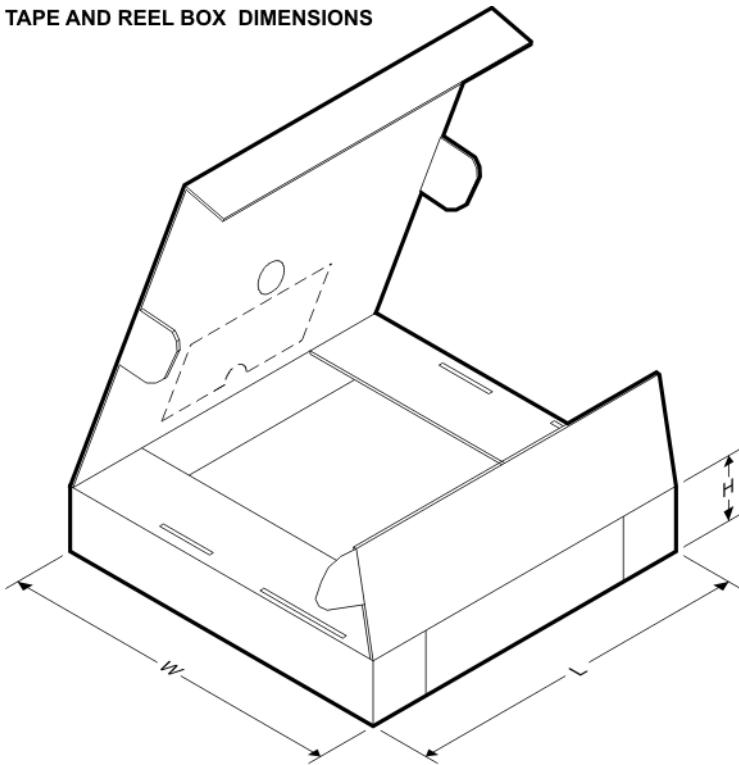

*All dimensions are nominal

Device	Package Type	Package Drawing	Pins	SPQ	Length (mm)	Width (mm)	Height (mm)
SN74LS594NSR	SO	NS	16	2000	346.0	346.0	33.0

IMPORTANT NOTICE

Texas Instruments Incorporated and its subsidiaries (TI) reserve the right to make corrections, modifications, enhancements, improvements, and other changes to its products and services at any time and to discontinue any product or service without notice. Customers should obtain the latest relevant information before placing orders and should verify that such information is current and complete. All products are sold subject to TI's terms and conditions of sale supplied at the time of order acknowledgment.

TI warrants performance of its hardware products to the specifications applicable at the time of sale in accordance with TI's standard warranty. Testing and other quality control techniques are used to the extent TI deems necessary to support this warranty. Except where mandated by government requirements, testing of all parameters of each product is not necessarily performed.

TI assumes no liability for applications assistance or customer product design. Customers are responsible for their products and applications using TI components. To minimize the risks associated with customer products and applications, customers should provide adequate design and operating safeguards.

TI does not warrant or represent that any license, either express or implied, is granted under any TI patent right, copyright, mask work right, or other TI intellectual property right relating to any combination, machine, or process in which TI products or services are used. Information published by TI regarding third-party products or services does not constitute a license from TI to use such products or services or a warranty or endorsement thereof. Use of such information may require a license from a third party under the patents or other intellectual property of the third party, or a license from TI under the patents or other intellectual property of TI.

Reproduction of TI information in TI data books or data sheets is permissible only if reproduction is without alteration and is accompanied by all associated warranties, conditions, limitations, and notices. Reproduction of this information with alteration is an unfair and deceptive business practice. TI is not responsible or liable for such altered documentation. Information of third parties may be subject to additional restrictions.

Resale of TI products or services with statements different from or beyond the parameters stated by TI for that product or service voids all express and any implied warranties for the associated TI product or service and is an unfair and deceptive business practice. TI is not responsible or liable for any such statements.

TI products are not authorized for use in safety-critical applications (such as life support) where a failure of the TI product would reasonably be expected to cause severe personal injury or death, unless officers of the parties have executed an agreement specifically governing such use. Buyers represent that they have all necessary expertise in the safety and regulatory ramifications of their applications, and acknowledge and agree that they are solely responsible for all legal, regulatory and safety-related requirements concerning their products and any use of TI products in such safety-critical applications, notwithstanding any applications-related information or support that may be provided by TI. Further, Buyers must fully indemnify TI and its representatives against any damages arising out of the use of TI products in such safety-critical applications.

TI products are neither designed nor intended for use in military/aerospace applications or environments unless the TI products are specifically designated by TI as military-grade or "enhanced plastic." Only products designated by TI as military-grade meet military specifications. Buyers acknowledge and agree that any such use of TI products which TI has not designated as military-grade is solely at the Buyer's risk, and that they are solely responsible for compliance with all legal and regulatory requirements in connection with such use.

TI products are neither designed nor intended for use in automotive applications or environments unless the specific TI products are designated by TI as compliant with ISO/TS 16949 requirements. Buyers acknowledge and agree that, if they use any non-designated products in automotive applications, TI will not be responsible for any failure to meet such requirements.

Following are URLs where you can obtain information on other Texas Instruments products and application solutions:

Products

Amplifiers	amplifier.ti.com
Data Converters	dataconverter.ti.com
DLP® Products	www.dlp.com
DSP	dsp.ti.com
Clocks and Timers	www.ti.com/clocks
Interface	interface.ti.com
Logic	logic.ti.com
Power Mgmt	power.ti.com
Microcontrollers	microcontroller.ti.com
RFID	www.ti-rfid.com
RF/IF and ZigBee® Solutions	www.ti.com/lprf

Applications

Audio	www.ti.com/audio
Automotive	www.ti.com/automotive
Broadband	www.ti.com/broadband
Digital Control	www.ti.com/digitalcontrol
Medical	www.ti.com/medical
Military	www.ti.com/military
Optical Networking	www.ti.com/opticalnetwork
Security	www.ti.com/security
Telephony	www.ti.com/telephony
Video & Imaging	www.ti.com/video
Wireless	www.ti.com/wireless

Mailing Address: Texas Instruments, Post Office Box 655303, Dallas, Texas 75265
Copyright © 2009, Texas Instruments Incorporated