

SN65LBC171, SN75LBC171 TRIPLE DIFFERENTIAL TRANSCIEVERS

SLLS460A – NOVEMBER 2000 – REVISED FEBRUARY 2001

AVAILABLE OPTIONS†

T _A	PACKAGE	
	PLASTIC SMALL-OUTLINE (JEDEC MS-013)	PLASTIC SHRINK SMALL-OUTLINE (JEDEC MO-150)
0°C to 70°C	SN75LBC171DW	SN75LBC171DB
-40°C to 85°C	SN65LBC171DW	SN65LBC171DB

† Add R suffix for taped and reel

Function Tables

EACH DRIVER

INPUT D	ENABLE		OUTPUTS	
	DE	CDE	A	B
H	H	H	H	L
L	H	H	L	H
OPEN	H	H	L	H
X	L	X	Z	Z
X	X	L	Z	Z
X	OPEN	X	Z	Z
X	X	OPEN	Z	Z

EACH RECEIVER

DIFFERENTIAL INPUT (V _A -V _B)	ENABLE RE	OUTPUT R
V _{ID} ≥ 0.2 V	L	H
-0.2 V < V _{ID} < 0.2 V	L	?
V _{ID} ≤ -0.2 V	L	L
X	H	Z
OPEN	L	H

H = high level, L = low level, X = irrelevant,
Z = high impedance (off), ? = indeterminate

equivalent input and output schematic diagrams

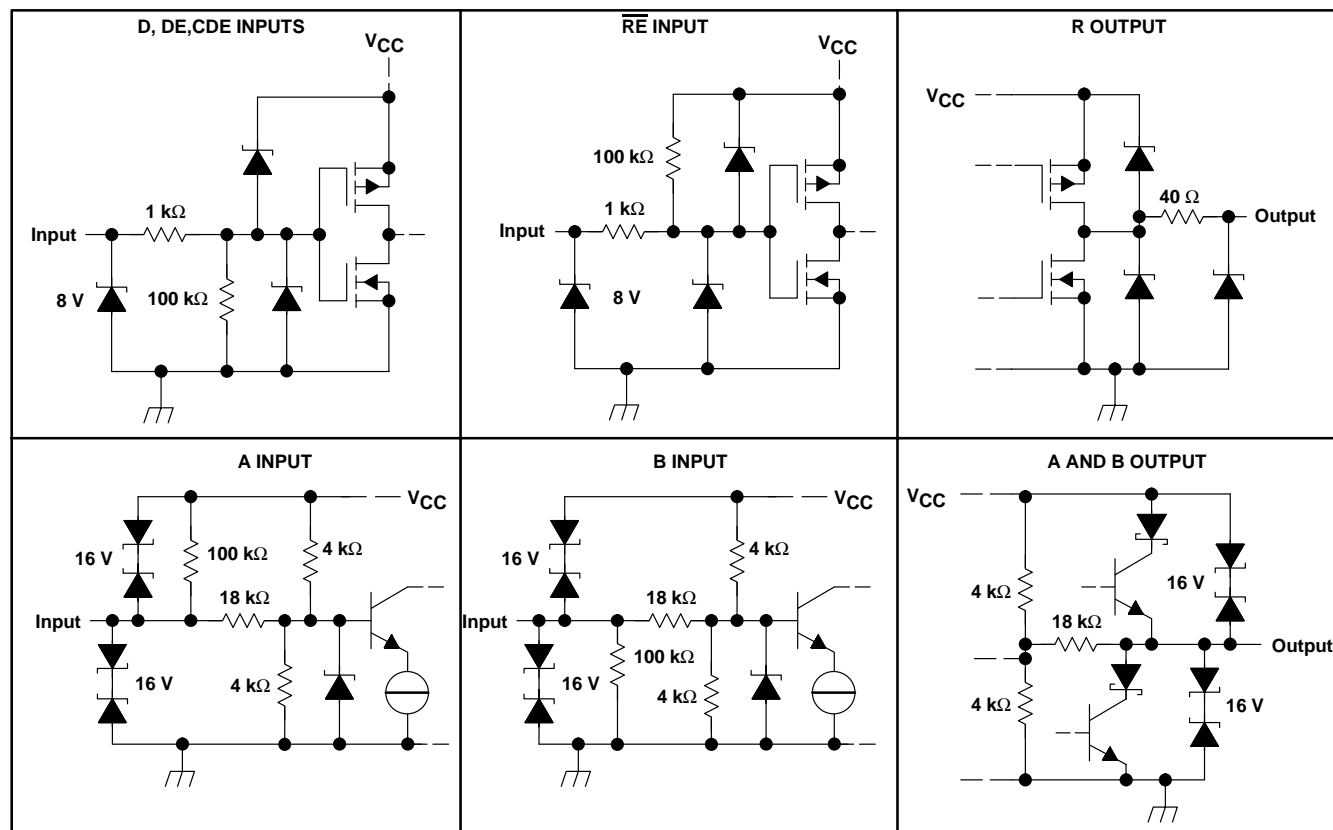

SN65LBC171, SN75LBC171 TRIPLE DIFFERENTIAL TRANSCEIVERS

SLLS460A – NOVEMBER 2000 – REVISED FEBRUARY 2001

absolute maximum ratings†

Supply voltage, V_{CC} (see Note 1)	–0.3 V to 6 V
Voltage range at any bus I/O terminal (steady state)	–10 V to 15 V
Voltage input range, A and B, (transient pulse through 100 Ω , see Figure 12)	–30 V to 30 V
Voltage range at any DE, \overline{RE} , or CDE terminal	–0.5 V to $V_{CC} + 0.5$ V
Electrostatic discharge: Human body model (A, B, GND) (see Note 2)	12 kV
All pins	5 kV
Charged-device model (all pins) (see Note 3)	1 kV
Continuous total power dissipation	See Power Dissipation Rating Table
Storage temperature range, T_{stg}	–65°C to 150°C
Lead temperature 1,6 mm (1/16 inch) from case for 10 seconds	260°C

† Stresses beyond those listed under “absolute maximum ratings” may cause permanent damage to the device. These are stress ratings only, and functional operation of the device at these or any other conditions beyond those indicated under “recommended operating conditions” is not implied. Exposure to absolute-maximum-rated conditions for extended periods may affect device reliability.

- NOTES: 1. All voltage values, except differential I/O bus voltages, are with respect to network ground terminal.
 2. Tested in accordance with JEDEC Standard 22, Test Method A114–A.
 3. Tested in accordance with JEDEC Standard 22, Test Method C101.

POWER DISSIPATION RATING TABLE

PACKAGE	$T_A \leq 25^\circ\text{C}$	DERATING FACTOR‡	$T_A = 70^\circ\text{C}$	$T_A = 85^\circ\text{C}$
	POWER RATING	ABOVE $T_A = 25^\circ\text{C}$	POWER RATING	POWER RATING
DB	995 mW	8.0 mW/°C	635 mW	515 mW
DW	1480 mW	11.8 mW/°C	950 mW	770 mW

‡ This is the inverse of the junction-to-ambient thermal resistance when board-mounted and with no air flow.

recommended operating conditions

		MIN	NOM	MAX	UNIT
Supply voltage, V_{CC}		4.75	5	5.25	V
Voltage at any bus I/O terminal	A, B	–7		12	V
High-level input voltage, V_{IH}	DE, CDE, RE	2		V_{CC}	V
Low-level input voltage, V_{IL}		0		0.8	
Differential input voltage, V_{ID}	A with respect to B	–12		12	V
Output current	Driver	–60		60	mA
	Receiver	–8		8	
Operating free-air temperature, T_A	SN75LBC171	0		70	°C
	SN65LBC171	–40		85	



SN65LBC171, SN75LBC171 TRIPLE DIFFERENTIAL TRANSCEIVERS

SLLS460A – NOVEMBER 2000 – REVISED FEBRUARY 2001

DRIVER SECTION

electrical characteristics over recommended operating conditions

PARAMETER		TEST CONDITIONS	MIN	TYP†	MAX	UNIT	
V_{IK}	Input clamp voltage	D, DE, CDE $I_I = 18 \text{ mA}$	-1.5	-0.7		V	
V_O	Open-circuit output voltage (single-ended)	A or B, No load	0		V_{CC}	V	
$ V_{OD(SS)} $	Steady-state differential output voltage magnitude‡	No load	3.8	4.3	V_{CC}	V	
		$R_L = 54 \Omega$, See Figure 1	1	1.6	2.4	V	
		With common-mode loading, See Figure 2	1	1.6	2.4	V	
ΔV_{OD}	Change in differential output voltage magnitude, $ V_{OD(H)} - V_{OD(L)} $	$R_L = 54 \Omega$, $C_L = 50 \text{ pF}$	See Figure 1	-0.2	0.2	V	
$V_{OC(SS)}$	Steady-state common-mode output voltage			2	2.4	2.8	V
$\Delta V_{OC(SS)}$	Change in steady-state common-mode output voltage ($V_{OC(H)} - V_{OC(L)}$)			-0.2	0.2	V	
I_I	Input current	D, DE, CDE	-100		100	μA	
I_O	Output current with power off	$V_{CC} = 0 \text{ V}$, $V_O = -7 \text{ V to } 12 \text{ V}$	-700		900	μA	
I_{OS}	Short-circuit output current	$V_O = -7 \text{ V to } 12 \text{ V}$, See Figure 7	-250		250	mA	
I_{CC}	Supply current (driver enabled)	D at 0 V or V_{CC} , CDE, DE, \overline{RE} at V_{CC} , No load		14	20	mA	

† All typical values are at $V_{CC} = 5 \text{ V}$ and $T_A = 25^\circ\text{C}$.

‡ The minimum V_{OD} may not fully comply with TIA/EIA-485-A at operating temperatures below 0°C . System designers should take the possibly lower output signal into account in determining the maximum signal-transmission distance.

switching characteristics over recommended operating conditions

PARAMETER		TEST CONDITIONS	MIN	TYP	MAX	UNIT
t_{PLH}	Differential output propagation delay, low-to-high	$R_L = 54 \Omega$, See Figure 3 $C_L = 50 \text{ pF}$,	4	8.5	12	ns
t_{PHL}	Differential output propagation delay, high-to-low		4	8.5	11	
t_r	Differential output rise time		3	7.5	11	
t_f	Differential output fall time		3	7.5	11	
$t_{sk(p)}$	Pulse skew $ (t_{PLH} - t_{PHL}) $				2	
$t_{sk(o)}$	Output skew§				1.5	
$t_{sk(pp)}$	Part-to-part skew¶				2	
t_{PLH}	Differential output propagation delay, low-to-high	See Figure 4, (HVD SCSI double-terminated load)	3	7	10	ns
t_{PHL}	Differential output propagation delay, high-to-low		3	7.5	10	
t_r	Differential output rise time		3	7.5	12	
t_f	Differential output fall time		3	7.5	12	
$t_{sk(p)}$	Pulse skew $ (t_{PLH} - t_{PHL}) $				3	
$t_{sk(o)}$	Output skew§				1.5	
$t_{sk(pp)}$	Part-to-part skew¶				2.5	
t_{PZH}	Output enable time to high level	See Figure 5		15	25	ns
t_{PHZ}	Output disable time from high level			18	25	
t_{PZL}	Output enable time to low level	See Figure 6		10	25	ns
t_{PLZ}	Output disable time from low level			17	25	

§ Output skew ($t_{sk(o)}$) is the magnitude of the time delay difference between the outputs of a single device with all of the inputs connected together.

¶ Part-to-part skew ($t_{sk(pp)}$) is the magnitude of the difference in propagation delay times between any specified terminals of two devices when both devices operate with the same input signals, the same supply voltages, at the same temperature, and have identical packages and test circuits.



RECEIVER SECTION

electrical characteristics over recommended operating conditions

PARAMETER		TEST CONDITIONS	MIN	TYP†	MAX	UNIT
V _{IT+}	Positive-going differential input voltage threshold				0.2	V
V _{IT-}	Negative-going differential input voltage threshold		-0.2			
V _{hys}	Hysteresis voltage (V _{IT+} - V _{IT-})			40		mV
V _{OH}	High-level output voltage	V _{ID} = 200 mV, I _{OH} = -8 mA, see Figure 10	4	4.7	V _{CC}	V
V _{OL}	Low-level output voltage	V _{ID} = -200 mV, I _{OL} = -8 mA, see Figure 10	0	0.2	0.4	
I _I	Line input current	Other input = 0 V	V _I = 12 V		0.9	mA
			V _I = -7 V		-0.7	
I _I	Input current	\overline{RE}	-100		100	μA
R _I	Input resistance	A, B	12			kΩ
I _{CC}	Supply current (receiver enabled)	A, B, D open, \overline{RE} , DE, and CDE at 0 V			16	mA

† All typical values are at V_{CC} = 5 V and T_A = 25°C.

switching characteristics over recommended operating conditions

PARAMETER		TEST CONDITIONS	MIN	TYP	MAX	UNIT
t _{PLH}	Propagation delay time, low-to-high level output	V _{ID} = -3 V to 3 V, See Figure 9	7		16	ns
t _{PHL}	Propagation delay time, high-to-low level output		7		16	ns
t _r	Receiver output rise time		1.3		3	ns
t _f	Receiver output fall time		1.3		3	ns
t _{PZH}	Receiver output enable time to high level	See Figure 10		26	40	ns
t _{PHZ}	Receiver output disable time from high level				40	
t _{PZL}	Receiver output enable time to low level	See Figure 11		29	40	ns
t _{PLZ}	Receiver output enable time to high level				40	
t _{sk(p)}	Pulse skew (t _{PLH} - t _{PHL})				2	ns
t _{sk(o)}	Output skew‡				1.5	ns
t _{sk(pp)}	Part-to-part skew§				3	ns

‡ Output skew (t_{sk(o)}) is the magnitude of the time delay difference between the outputs of a single device with all of the inputs connected together.

§ Part-to-part skew (t_{sk(pp)}) is the magnitude of the difference in propagation delay times between any specified terminals of two devices when both devices operate with the same input signals, the same supply voltages, at the same temperature, and have identical packages and test circuits.

SN65LBC171, SN75LBC171 TRIPLE DIFFERENTIAL TRANSCIEVERS

SLLS460A – NOVEMBER 2000 – REVISED FEBRUARY 2001

PARAMETER MEASUREMENT INFORMATION

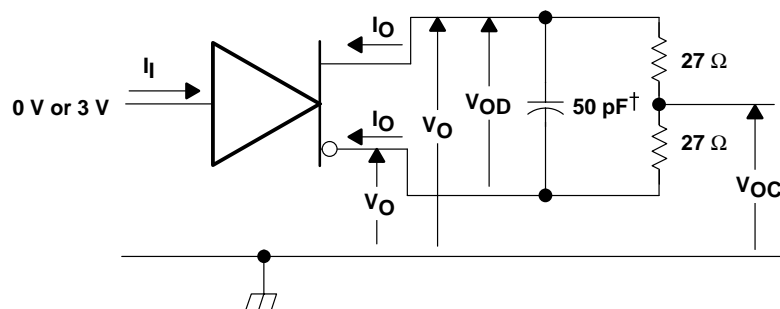

†Includes probe and jig capacitance

Figure 1. Driver Test Circuit, V_{OD} and V_{OC} Without Common-Mode Loading

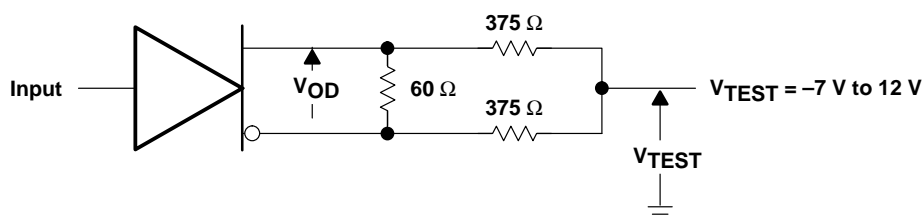
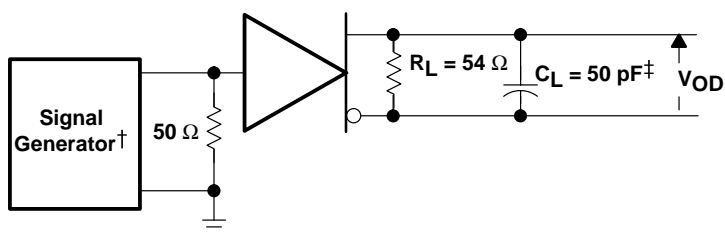

Figure 2. Driver Test Circuit, V_{OD} With Common-Mode Loading



† PRR = 1 MHz, 50% Duty Cycle, $t_r < 6$ ns, $t_f < 6$ ns, $Z_0 = 50 \Omega$

‡ Includes Probe and Jig Capacitance

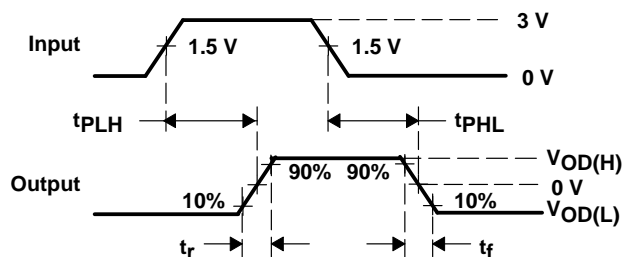
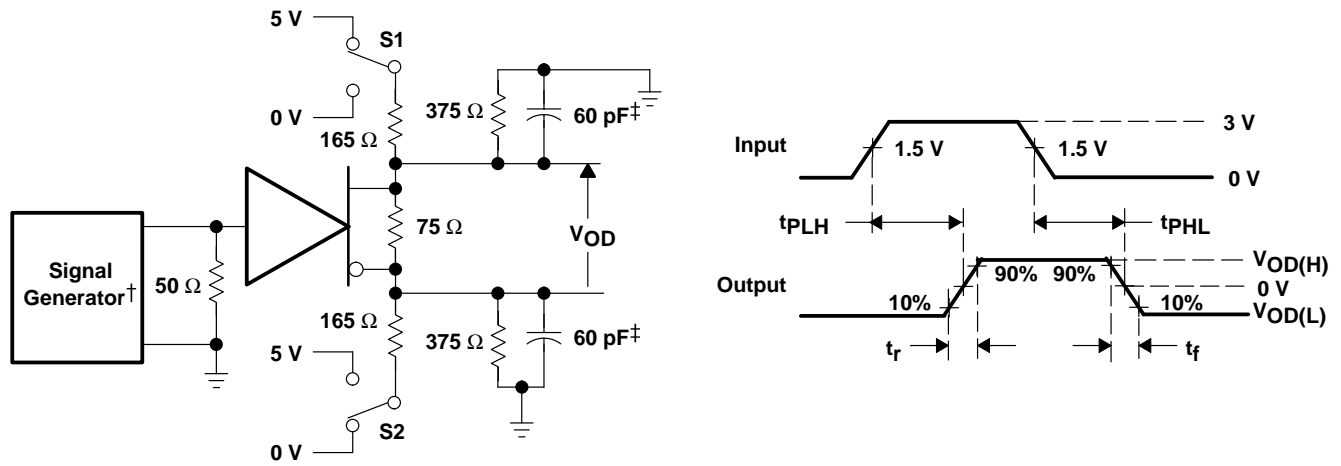

Figure 3. Driver Switching Test Circuit and Waveforms, 485-Loading

PARAMETER MEASUREMENT INFORMATION



† PRR = 1 MHz, 50% Duty Cycle, $t_r < 6$ ns, $t_f < 6$ ns, $Z_0 = 50 \Omega$

‡ Includes Probe and Jig Capacitance

Figure 4. Driver Switching Test Circuit and Waveforms, HVD SCSI-Loading (double terminated)

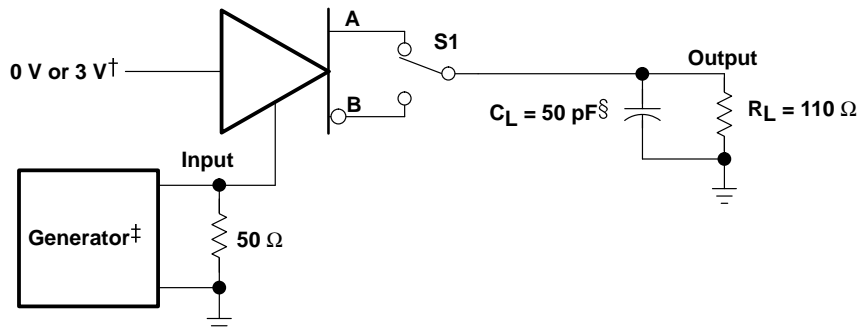

† 3 V if testing A output, 0 V if testing B output

‡ PRR = 1 MHz, 50% Duty Cycle, $t_r < 6$ ns, $t_f < 6$ ns, $Z_0 = 50 \Omega$

§ Includes Probe and Jig Capacitance

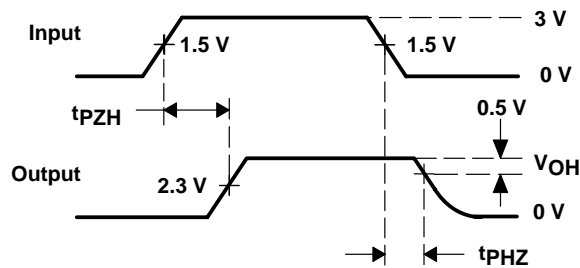
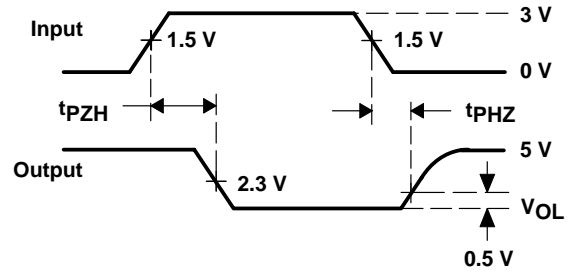
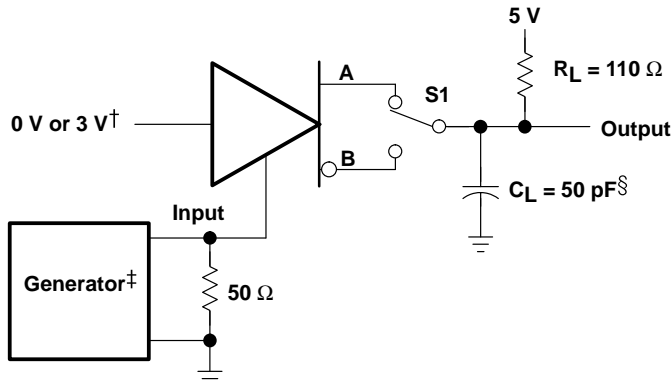

Figure 5. Driver Enable/Disable Test, High Output

SN65LBC171, SN75LBC171 TRIPLE DIFFERENTIAL TRANSCIEVERS

SLLS460A – NOVEMBER 2000 – REVISED FEBRUARY 2001

PARAMETER MEASUREMENT INFORMATION



† 0 V if testing A output, 3 V if testing B output
‡ PRR = 1 MHz, 50% Duty Cycle, $t_r < 6$ ns, $t_f < 6$ ns, $Z_0 = 50 \Omega$
§ Includes Probe and Jig Capacitance

Figure 6. Driver Enable/Disable Test, Low Output

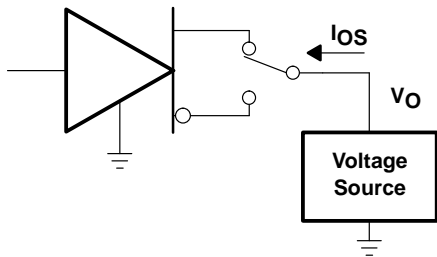

Figure 7. Driver Short-Circuit Test

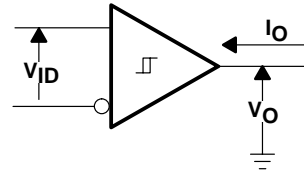
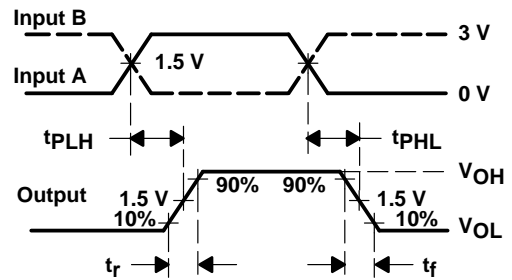
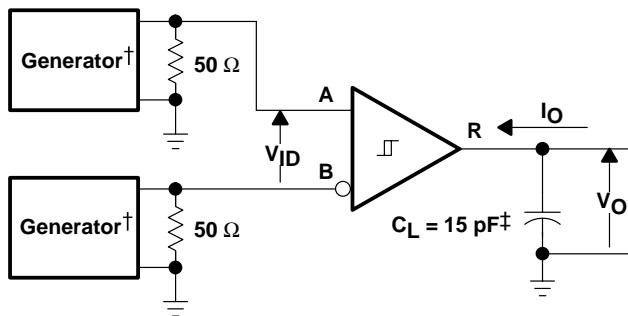

Figure 8. Receiver DC Parameters



† PRR = 1 MHz, 50% Duty Cycle, $t_r < 6$ ns, $t_f < 6$ ns, $Z_0 = 50 \Omega$
‡ Includes Probe and Jig Capacitance

Figure 9. Receiver Switching Test Circuit and Waveforms

PARAMETER MEASUREMENT INFORMATION

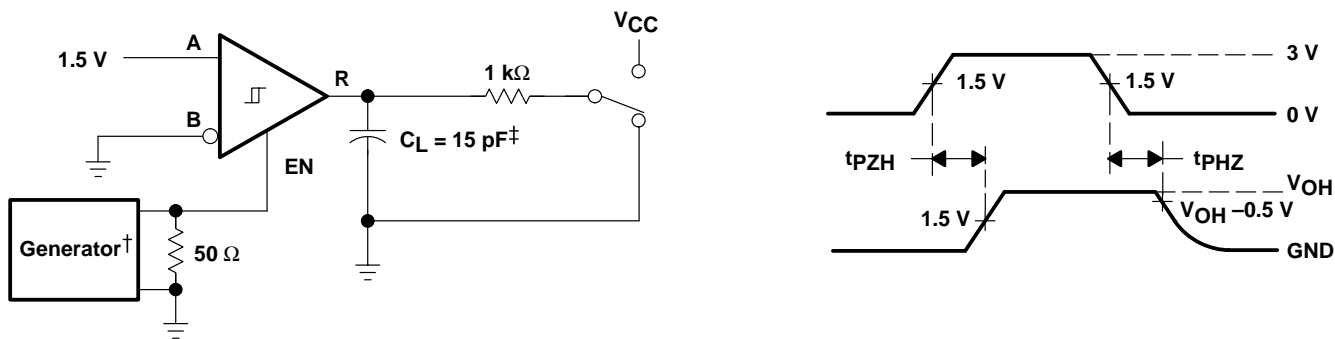

† PRR = 1 MHz, 50% Duty Cycle, $t_r < 6$ ns, $t_f < 6$ ns, $Z_0 = 50 \Omega$
‡ Includes Probe and Jig Capacitance

Figure 10. Receiver Enable/Disable Test, High Output

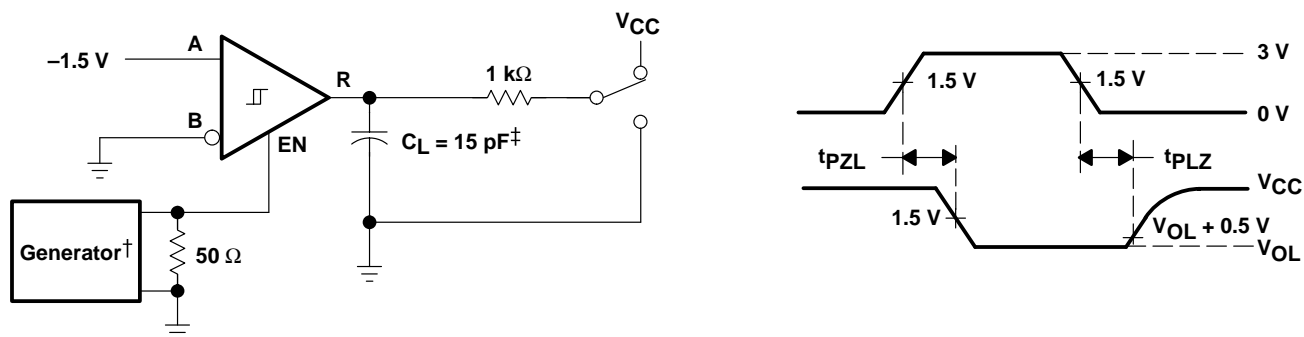

† PRR = 1 MHz, 50% Duty Cycle, $t_r < 6$ ns, $t_f < 6$ ns, $Z_0 = 50 \Omega$
‡ Includes Probe and Jig Capacitance

Figure 11. Receiver Enable/Disable Test, Low Output

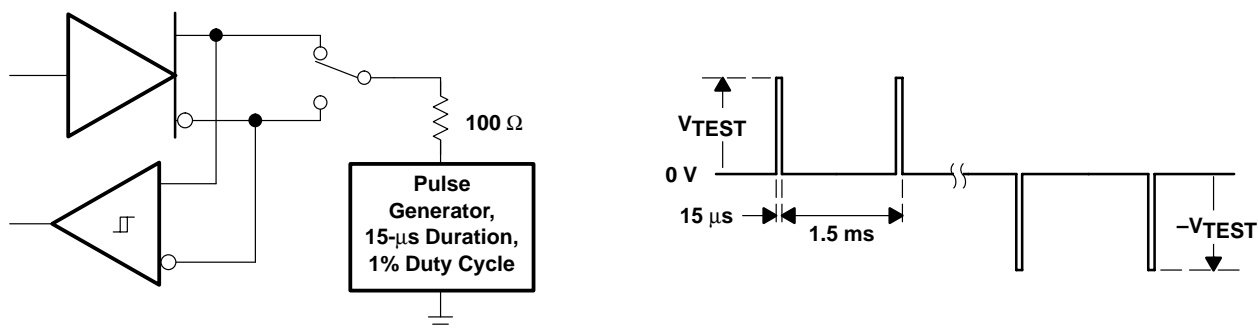

Figure 12. Test Circuit and Waveform, Transient Over Voltage Test

SN65LBC171, SN75LBC171 TRIPLE DIFFERENTIAL TRANSCEIVERS

SLLS460A – NOVEMBER 2000 – REVISED FEBRUARY 2001

TYPICAL CHARACTERISTICS

DIFFERENTIAL OUTPUT VOLTAGE
vs
OUTPUT CURRENT

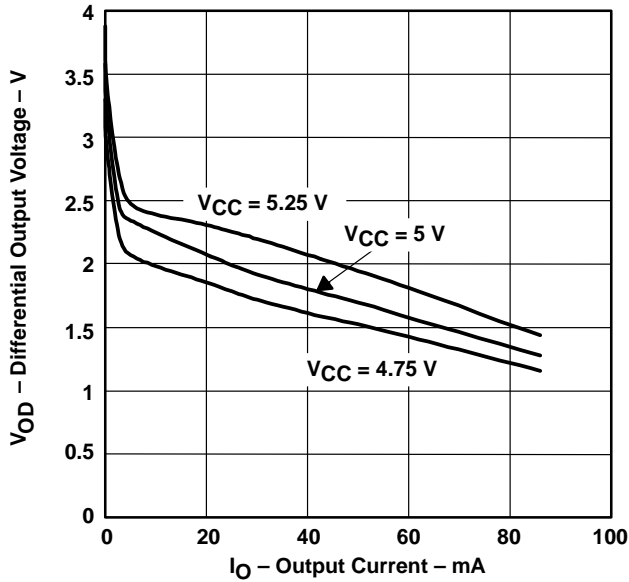

Figure 13

DIFFERENTIAL OUTPUT VOLTAGE
vs
FREE-AIR TEMPERATURE

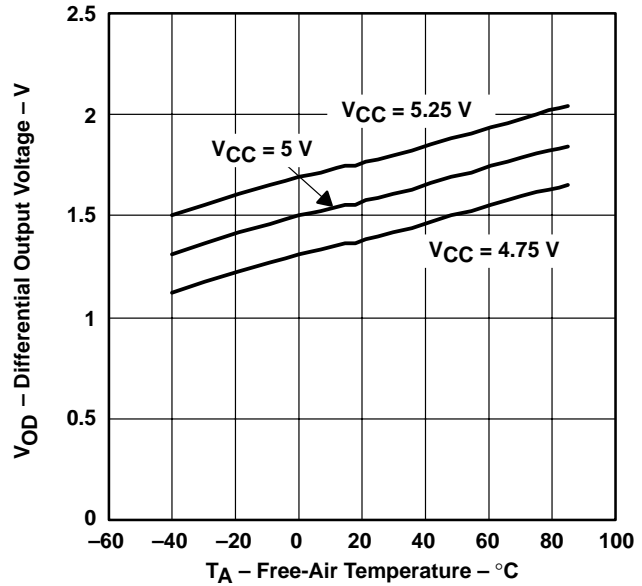

Figure 14

DRIVER PROPAGATION DELAY
vs
FREE-AIR TEMPERATURE

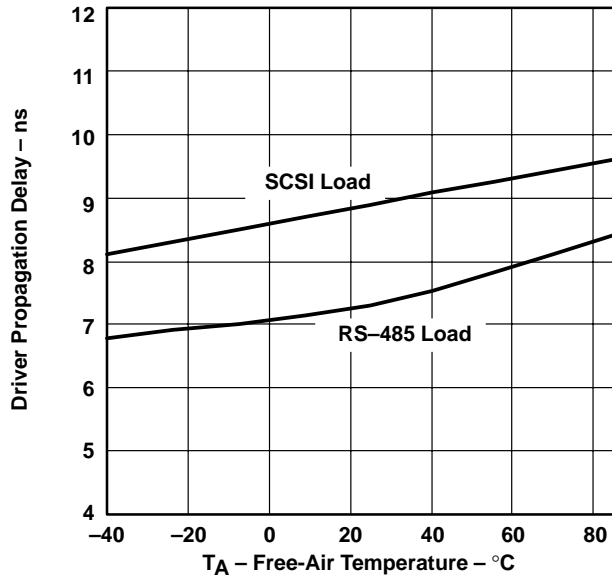

Figure 15

SUPPLY CURRENT
vs
SIGNALING RATE

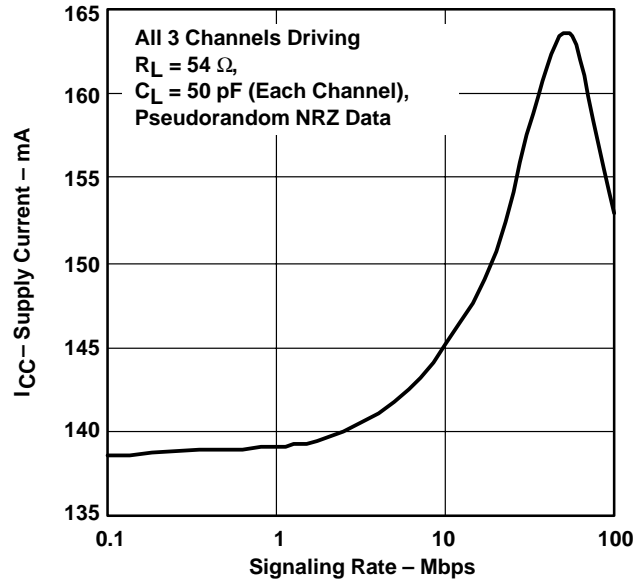

Figure 16



TYPICAL CHARACTERISTICS

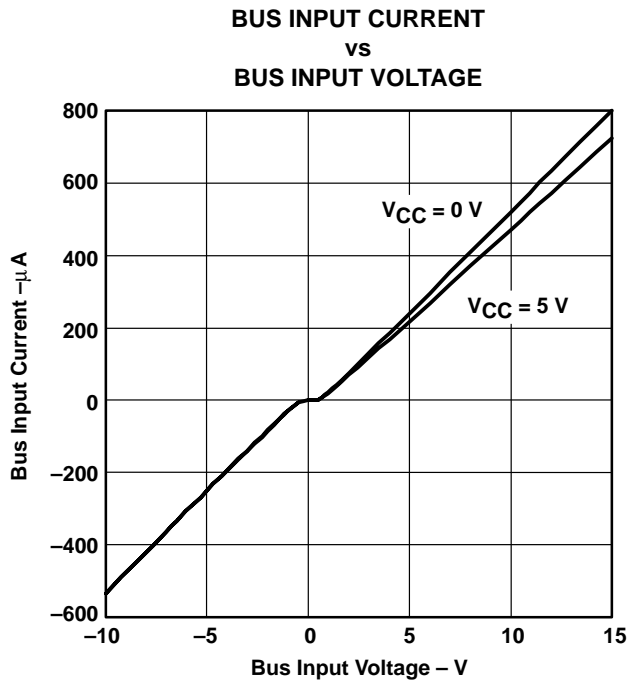

Figure 17

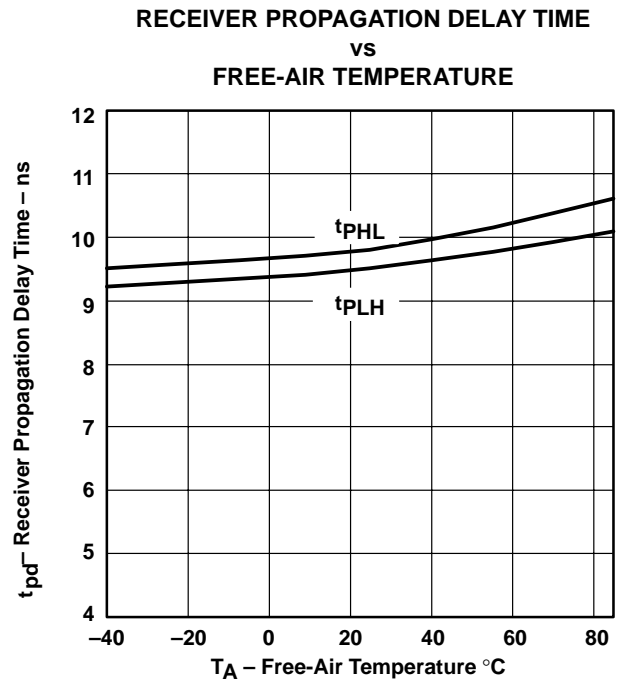

Figure 18

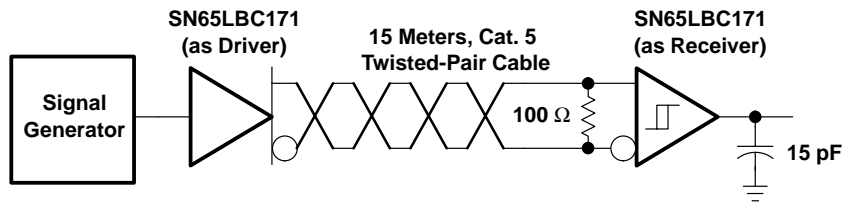

Figure 19. Circuit Diagram for Signaling Characteristics

SN65LBC171, SN75LBC171 TRIPLE DIFFERENTIAL TRANSCEIVERS

SLLS460A – NOVEMBER 2000 – REVISED FEBRUARY 2001

TYPICAL CHARACTERISTICS

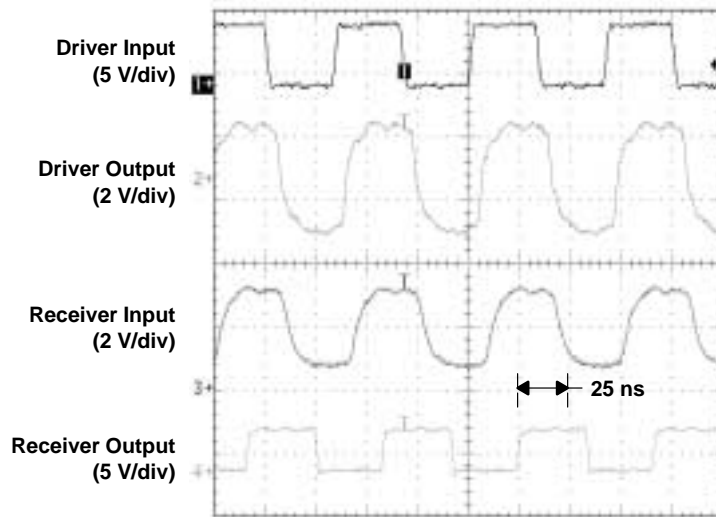

Figure 20. Signal Waveforms at 30 Mbps

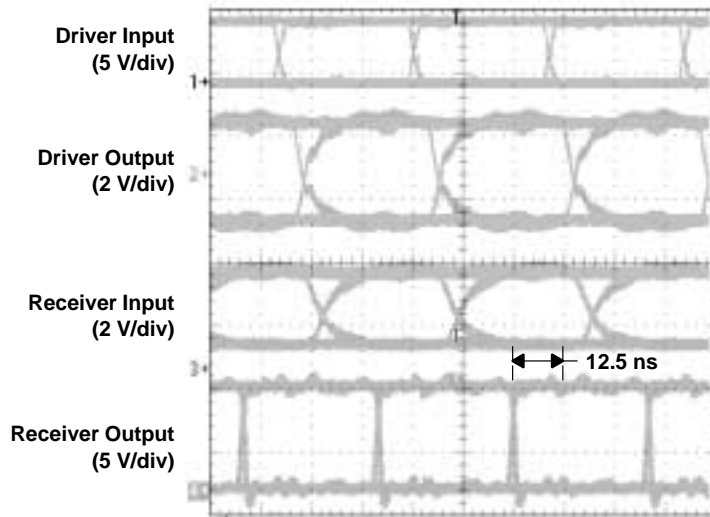

Figure 21. Eye Patterns, Pseudorandom Data at 30 Mbps

TYPICAL CHARACTERISTICS

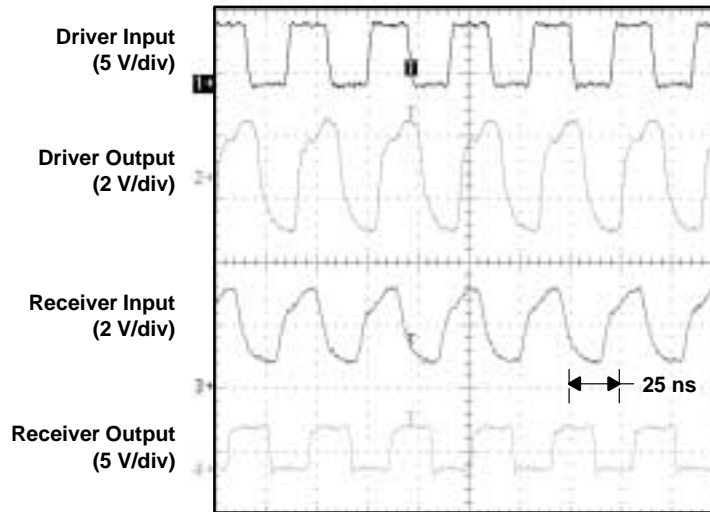

Figure 22. Signal Waveforms at 50 Mbps

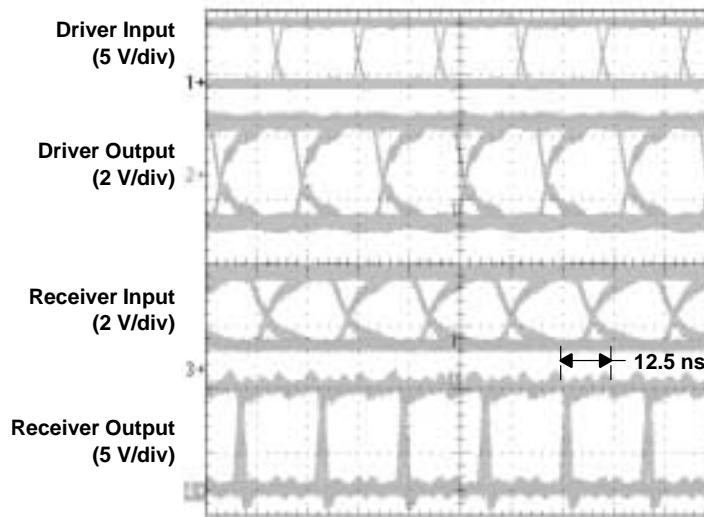

Figure 23. Eye Patterns, Pseudorandom Data at 50 Mbps

SN65LBC171, SN75LBC171 TRIPLE DIFFERENTIAL TRANSCEIVERS

SLLS460A – NOVEMBER 2000 – REVISED FEBRUARY 2001

MECHANICAL DATA

DB (R-PDSO-G**)

PLASTIC SMALL-OUTLINE

28 PINS SHOWN

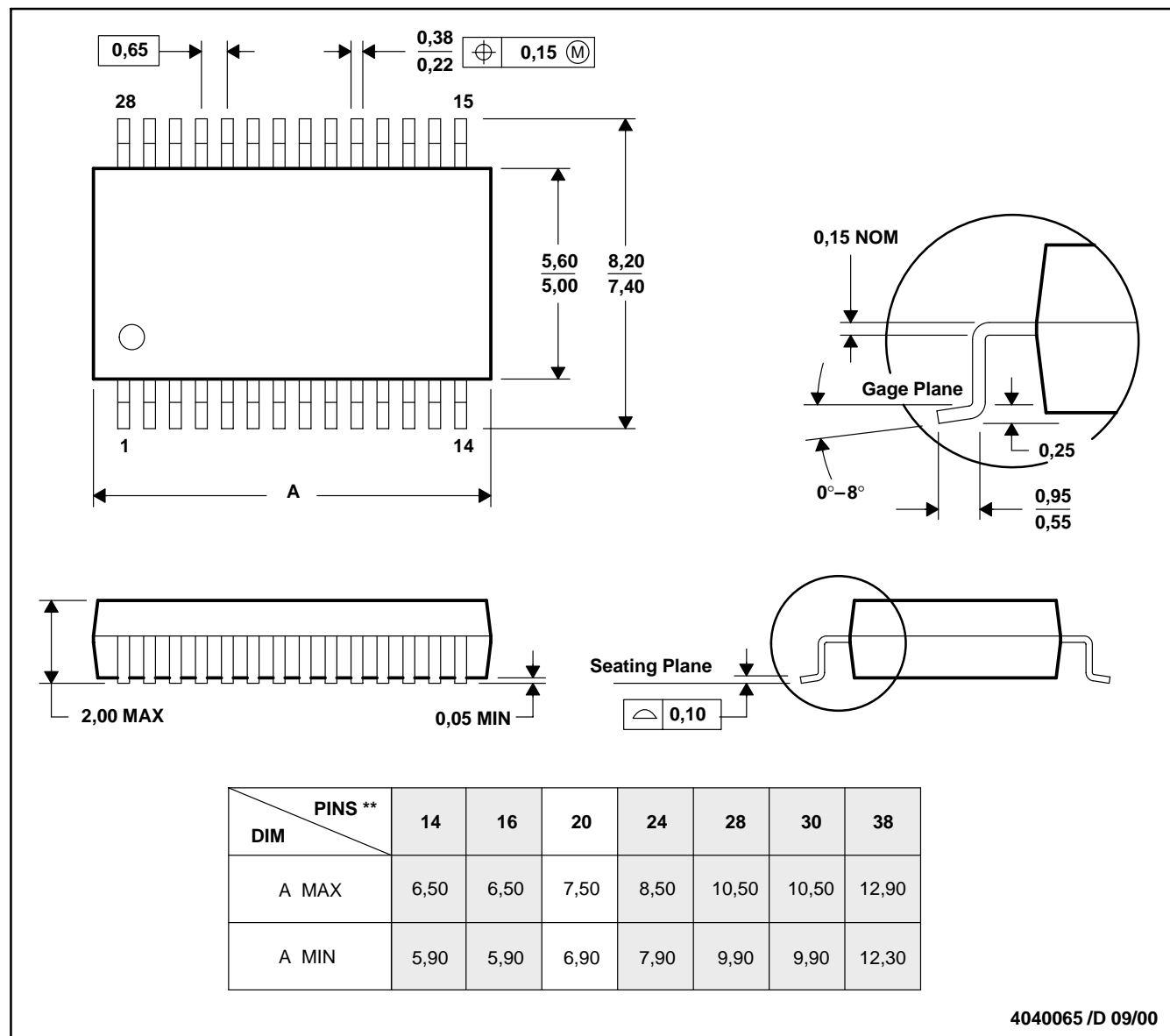

- NOTES: A. All linear dimensions are in millimeters.
 B. This drawing is subject to change without notice.
 C. Body dimensions do not include mold flash or protrusion not to exceed 0,15.
 D. Falls within JEDEC MO-150



POST OFFICE BOX 655303 • DALLAS, TEXAS 75265

SN65LBC171, SN75LBC171 TRIPLE DIFFERENTIAL TRANSCEIVERS

SLLS460A – NOVEMBER 2000 – REVISED FEBRUARY 2001

MECHANICAL DATA

DW (R-PDSO-G**)

PLASTIC SMALL-OUTLINE PACKAGE

16 PINS SHOWN

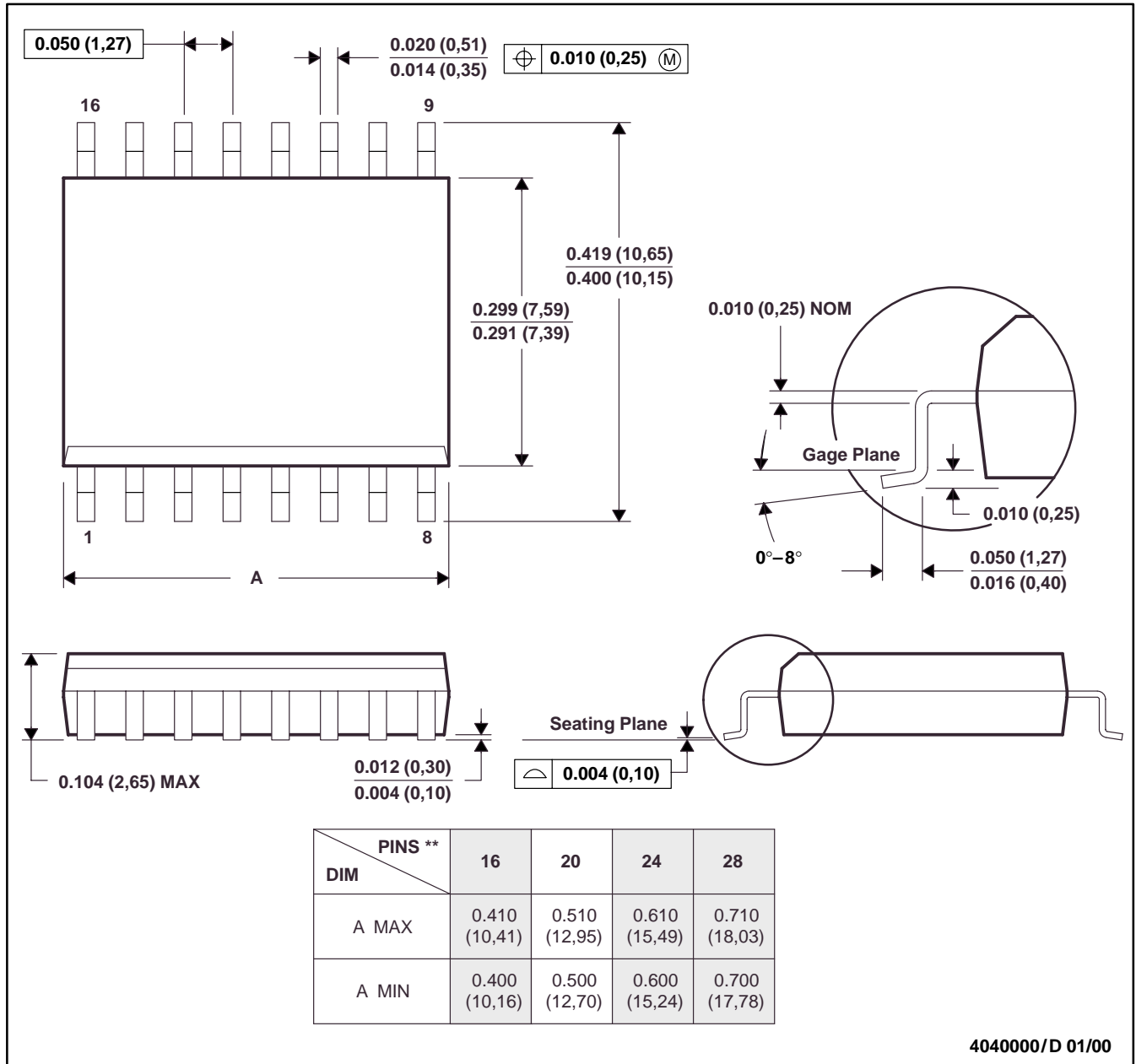

- NOTES: A. All linear dimensions are in inches (millimeters).
 B. This drawing is subject to change without notice.
 C. Body dimensions do not include mold flash or protrusion not to exceed 0.006 (0,15).
 D. Falls within JEDEC MS-013

PACKAGING INFORMATION

Orderable Device	Status ⁽¹⁾	Package Type	Package Drawing	Pins	Package Qty	Eco Plan ⁽²⁾	Lead/Ball Finish	MSL Peak Temp ⁽³⁾
SN65LBC171DB	ACTIVE	SSOP	DB	20	70	Green (RoHS & no Sb/Br)	CU NIPDAU	Level-1-260C-UNLIM
SN65LBC171DBG4	ACTIVE	SSOP	DB	20	70	Green (RoHS & no Sb/Br)	CU NIPDAU	Level-1-260C-UNLIM
SN65LBC171DBR	ACTIVE	SSOP	DB	20	2000	Green (RoHS & no Sb/Br)	CU NIPDAU	Level-1-260C-UNLIM
SN65LBC171DBRG4	ACTIVE	SSOP	DB	20	2000	Green (RoHS & no Sb/Br)	CU NIPDAU	Level-1-260C-UNLIM
SN65LBC171DW	ACTIVE	SOIC	DW	20	25	Green (RoHS & no Sb/Br)	CU NIPDAU	Level-1-260C-UNLIM
SN65LBC171DWG4	ACTIVE	SOIC	DW	20	25	Green (RoHS & no Sb/Br)	CU NIPDAU	Level-1-260C-UNLIM
SN65LBC171DWR	ACTIVE	SOIC	DW	20	2000	Green (RoHS & no Sb/Br)	CU NIPDAU	Level-1-260C-UNLIM
SN65LBC171DWRG4	ACTIVE	SOIC	DW	20	2000	Green (RoHS & no Sb/Br)	CU NIPDAU	Level-1-260C-UNLIM
SN75LBC171DB	ACTIVE	SSOP	DB	20	70	Green (RoHS & no Sb/Br)	CU NIPDAU	Level-1-260C-UNLIM
SN75LBC171DBG4	ACTIVE	SSOP	DB	20	70	Green (RoHS & no Sb/Br)	CU NIPDAU	Level-1-260C-UNLIM
SN75LBC171DW	ACTIVE	SOIC	DW	20	25	Green (RoHS & no Sb/Br)	CU NIPDAU	Level-1-260C-UNLIM
SN75LBC171DWG4	ACTIVE	SOIC	DW	20	25	Green (RoHS & no Sb/Br)	CU NIPDAU	Level-1-260C-UNLIM

⁽¹⁾ The marketing status values are defined as follows:

ACTIVE: Product device recommended for new designs.

LIFEBUY: TI has announced that the device will be discontinued, and a lifetime-buy period is in effect.

NRND: Not recommended for new designs. Device is in production to support existing customers, but TI does not recommend using this part in a new design.

PREVIEW: Device has been announced but is not in production. Samples may or may not be available.

OBSOLETE: TI has discontinued the production of the device.

⁽²⁾ Eco Plan - The planned eco-friendly classification: Pb-Free (RoHS), Pb-Free (RoHS Exempt), or Green (RoHS & no Sb/Br) - please check <http://www.ti.com/productcontent> for the latest availability information and additional product content details.

TBD: The Pb-Free/Green conversion plan has not been defined.

Pb-Free (RoHS): TI's terms "Lead-Free" or "Pb-Free" mean semiconductor products that are compatible with the current RoHS requirements for all 6 substances, including the requirement that lead not exceed 0.1% by weight in homogeneous materials. Where designed to be soldered at high temperatures, TI Pb-Free products are suitable for use in specified lead-free processes.

Pb-Free (RoHS Exempt): This component has a RoHS exemption for either 1) lead-based flip-chip solder bumps used between the die and package, or 2) lead-based die adhesive used between the die and leadframe. The component is otherwise considered Pb-Free (RoHS compatible) as defined above.

Green (RoHS & no Sb/Br): TI defines "Green" to mean Pb-Free (RoHS compatible), and free of Bromine (Br) and Antimony (Sb) based flame retardants (Br or Sb do not exceed 0.1% by weight in homogeneous material)

⁽³⁾ MSL, Peak Temp. -- The Moisture Sensitivity Level rating according to the JEDEC industry standard classifications, and peak solder temperature.

Important Information and Disclaimer: The information provided on this page represents TI's knowledge and belief as of the date that it is provided. TI bases its knowledge and belief on information provided by third parties, and makes no representation or warranty as to the accuracy of such information. Efforts are underway to better integrate information from third parties. TI has taken and continues to take reasonable steps to provide representative and accurate information but may not have conducted destructive testing or chemical analysis on incoming materials and chemicals. TI and TI suppliers consider certain information to be proprietary, and thus CAS numbers and other limited information may not be available for release.

In no event shall TI's liability arising out of such information exceed the total purchase price of the TI part(s) at issue in this document sold by TI to Customer on an annual basis.

TAPE AND REEL INFORMATION

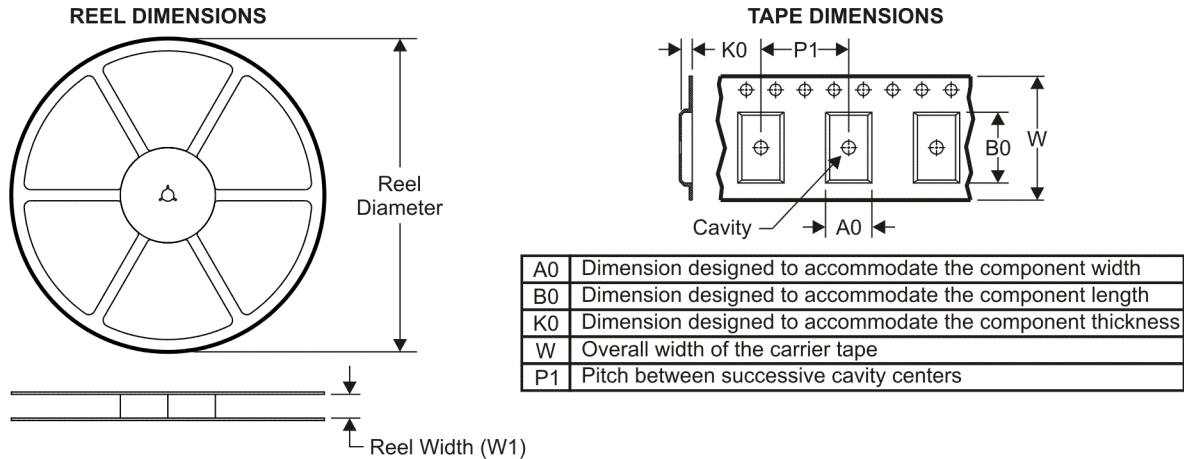

QUADRANT ASSIGNMENTS FOR PIN 1 ORIENTATION IN TAPE

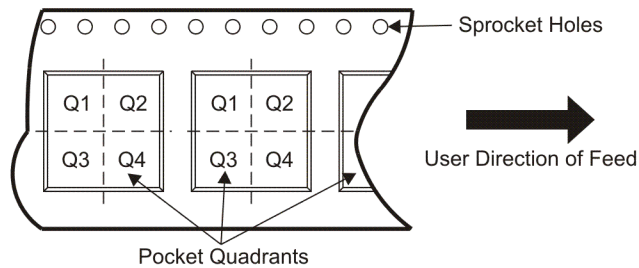

*All dimensions are nominal

Device	Package Type	Package Drawing	Pins	SPQ	Reel Diameter (mm)	Reel Width W1 (mm)	A0 (mm)	B0 (mm)	K0 (mm)	P1 (mm)	W (mm)	Pin1 Quadrant
SN65LBC171DBR	SSOP	DB	20	2000	330.0	16.4	8.2	7.5	2.5	12.0	16.0	Q1
SN65LBC171DWR	SOIC	DW	20	2000	330.0	24.4	10.8	13.0	2.7	12.0	24.0	Q1

TAPE AND REEL BOX DIMENSIONS

*All dimensions are nominal

Device	Package Type	Package Drawing	Pins	SPQ	Length (mm)	Width (mm)	Height (mm)
SN65LBC171DBR	SSOP	DB	20	2000	346.0	346.0	33.0
SN65LBC171DWR	SOIC	DW	20	2000	346.0	346.0	41.0

IMPORTANT NOTICE

Texas Instruments Incorporated and its subsidiaries (TI) reserve the right to make corrections, modifications, enhancements, improvements, and other changes to its products and services at any time and to discontinue any product or service without notice. Customers should obtain the latest relevant information before placing orders and should verify that such information is current and complete. All products are sold subject to TI's terms and conditions of sale supplied at the time of order acknowledgment.

TI warrants performance of its hardware products to the specifications applicable at the time of sale in accordance with TI's standard warranty. Testing and other quality control techniques are used to the extent TI deems necessary to support this warranty. Except where mandated by government requirements, testing of all parameters of each product is not necessarily performed.

TI assumes no liability for applications assistance or customer product design. Customers are responsible for their products and applications using TI components. To minimize the risks associated with customer products and applications, customers should provide adequate design and operating safeguards.

TI does not warrant or represent that any license, either express or implied, is granted under any TI patent right, copyright, mask work right, or other TI intellectual property right relating to any combination, machine, or process in which TI products or services are used. Information published by TI regarding third-party products or services does not constitute a license from TI to use such products or services or a warranty or endorsement thereof. Use of such information may require a license from a third party under the patents or other intellectual property of the third party, or a license from TI under the patents or other intellectual property of TI.

Reproduction of TI information in TI data books or data sheets is permissible only if reproduction is without alteration and is accompanied by all associated warranties, conditions, limitations, and notices. Reproduction of this information with alteration is an unfair and deceptive business practice. TI is not responsible or liable for such altered documentation. Information of third parties may be subject to additional restrictions.

Resale of TI products or services with statements different from or beyond the parameters stated by TI for that product or service voids all express and any implied warranties for the associated TI product or service and is an unfair and deceptive business practice. TI is not responsible or liable for any such statements.

TI products are not authorized for use in safety-critical applications (such as life support) where a failure of the TI product would reasonably be expected to cause severe personal injury or death, unless officers of the parties have executed an agreement specifically governing such use. Buyers represent that they have all necessary expertise in the safety and regulatory ramifications of their applications, and acknowledge and agree that they are solely responsible for all legal, regulatory and safety-related requirements concerning their products and any use of TI products in such safety-critical applications, notwithstanding any applications-related information or support that may be provided by TI. Further, Buyers must fully indemnify TI and its representatives against any damages arising out of the use of TI products in such safety-critical applications.

TI products are neither designed nor intended for use in military/aerospace applications or environments unless the TI products are specifically designated by TI as military-grade or "enhanced plastic." Only products designated by TI as military-grade meet military specifications. Buyers acknowledge and agree that any such use of TI products which TI has not designated as military-grade is solely at the Buyer's risk, and that they are solely responsible for compliance with all legal and regulatory requirements in connection with such use.

TI products are neither designed nor intended for use in automotive applications or environments unless the specific TI products are designated by TI as compliant with ISO/TS 16949 requirements. Buyers acknowledge and agree that, if they use any non-designated products in automotive applications, TI will not be responsible for any failure to meet such requirements.

Following are URLs where you can obtain information on other Texas Instruments products and application solutions:

Products

Amplifiers	amplifier.ti.com
Data Converters	dataconverter.ti.com
DLP® Products	www.dlp.com
DSP	dsp.ti.com
Clocks and Timers	www.ti.com/clocks
Interface	interface.ti.com
Logic	logic.ti.com
Power Mgmt	power.ti.com
Microcontrollers	microcontroller.ti.com
RFID	www.ti-rfid.com
RF/IF and ZigBee® Solutions	www.ti.com/lprf

Applications

Audio	www.ti.com/audio
Automotive	www.ti.com/automotive
Broadband	www.ti.com/broadband
Digital Control	www.ti.com/digitalcontrol
Medical	www.ti.com/medical
Military	www.ti.com/military
Optical Networking	www.ti.com/opticalnetwork
Security	www.ti.com/security
Telephony	www.ti.com/telephony
Video & Imaging	www.ti.com/video
Wireless	www.ti.com/wireless

Mailing Address: Texas Instruments, Post Office Box 655303, Dallas, Texas 75265
Copyright © 2009, Texas Instruments Incorporated