

SN55LBC173 QUADRUPLE LOW-POWER DIFFERENTIAL RECEIVER

SGLS081A – MARCH 1995 – REVISED JUNE 2000

- Meets EIA Standards RS-422-A, RS-423-A, RS-485, and CCITT V.11
- Designed to Operate With Pulse Durations as Short as 20 ns
- Designed for Multipoint Bus Transmission on Long Bus Lines in Noisy Environments
- Input Sensitivity . . . ± 200 mV
- Low-Power Consumption . . . 20 mA Max
- Open-Circuit Fail-Safe Design
- Pin Compatible With SN75173 and AM26LS32

description

The SN55LBC173 is a monolithic quadruple differential line receiver with 3-state outputs designed to meet the requirements of the EIA standards RS-422-A, RS-423-A, RS-485, and CCITT V.11. This device is optimized for balanced multipoint bus transmission at data rates up to and exceeding 10 million bits per second. The four receivers share two ORed enable inputs, one active when high, the other active when low. Each receiver features high input impedance, input hysteresis for increased noise immunity, and input sensitivity of ± 200 mV over a common-mode input voltage range of 12 V to -7 V. Fail-safe design ensures that if the inputs are open circuited, the output is always high. The SN55LBC173 is designed using the Texas Instruments proprietary LinBiCMOS™ technology that provides low power consumption, high switching speeds, and robustness.

This device offers optimum performance when used with the SN55LBC172M quadruple line driver. The SN55LBC173 is available in the 16-pin CDIP (J), the 16-pin CPAK (W), or the 20-pin LCCC (FK) packages.

The SN55LBC173 is characterized over the military temperature range of -55°C to 125°C .

J OR W PACKAGE
(TOP VIEW)

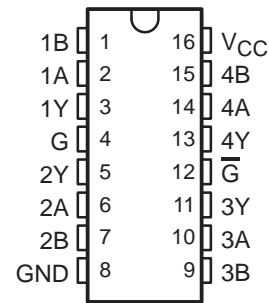

FK PACKAGE
(TOP VIEW)

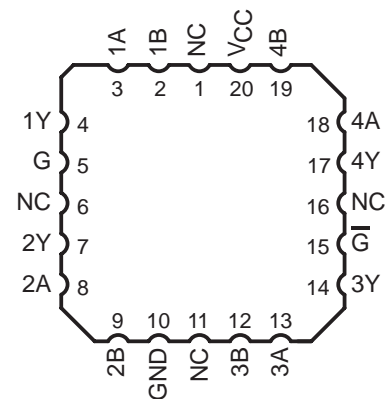

NC – No internal connection



Please be aware that an important notice concerning availability, standard warranty, and use in critical applications of Texas Instruments semiconductor products and disclaimers thereto appears at the end of this data sheet.

LinBiCMOS is a trademark of Texas Instruments.

PRODUCTION DATA information is current as of publication date. Products conform to specifications per the terms of Texas Instruments standard warranty. Production processing does not necessarily include testing of all parameters.

 **TEXAS
INSTRUMENTS**

POST OFFICE BOX 655303 • DALLAS, TEXAS 75265

Copyright © 2000, Texas Instruments Incorporated

SN55LBC173 QUADRUPLE LOW-POWER DIFFERENTIAL RECEIVER

SGLS081A – MARCH 1995 – REVISED JUNE 2000

FUNCTION TABLE
(each receiver)

DIFFERENTIAL INPUTS A–B	ENABLES		OUTPUT Y
	G	\overline{G}	
$V_{ID} \geq 0.2 V$	H X	X L	H H
$-0.2 V < V_{ID} < 0.2 V$	H X	X L	? ?
$V_{ID} \leq -0.2 V$	H X	X L	L L
X	L H	H L	Z
Open circuit	H X	X L	H H

H = high level, L = low level, X = irrelevant,
Z = high impedance (off), ? = indeterminate

logic symbol†

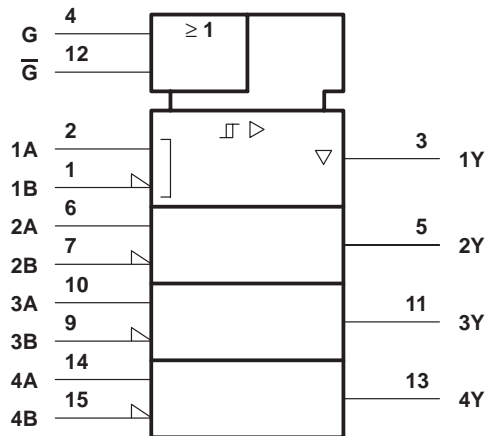

† This symbol is in accordance with ANSI/IEEE Std 91-1984 and IEC Publication 617-12.

Pin numbers shown are for the J or W package.

logic diagram (positive logic)

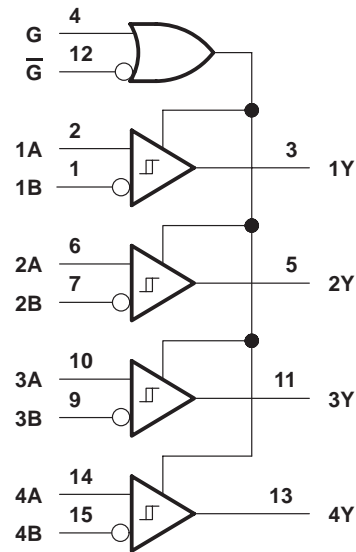

schematics of inputs and outputs

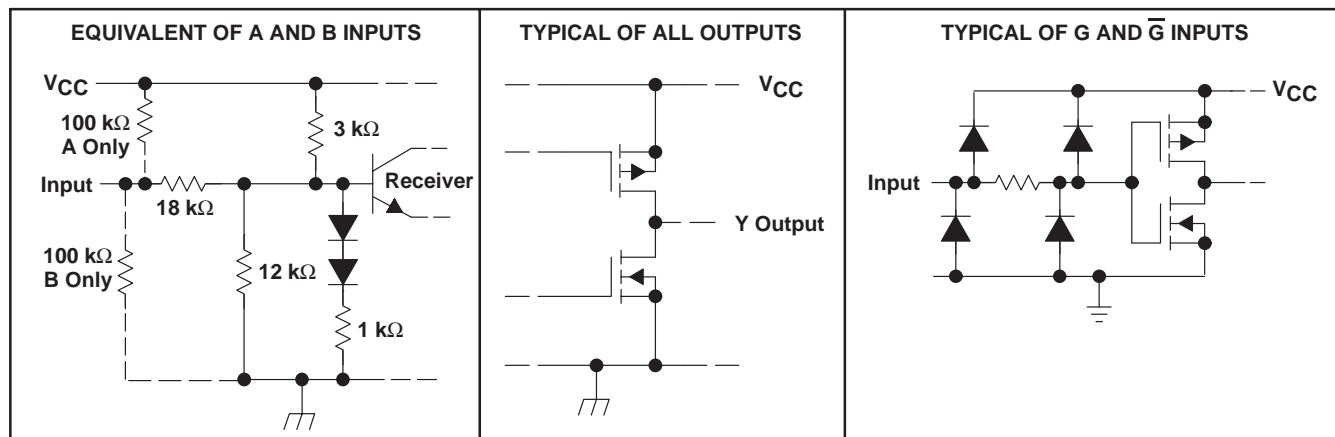

absolute maximum ratings over operating free-air temperature range (unless otherwise noted)†

Supply voltage range, V_{CC} (see Note 1)	–0.3 V to 7 V
Input voltage, V_I (A or B inputs)	±25 V
Differential input voltage, V_{ID} (see Note 2)	±25 V
Data and control voltage range	–0.3 V to 7 V
Continuous total dissipation	See Dissipation Rating Table
Operating free-air temperature range, T_A	–55°C to 125°C
Storage temperature range, T_{stg}	–65°C to 150°C
Lead temperature 1,6 mm (1/16 inch) from case for 10 seconds	260°C

† Stresses beyond those listed under “absolute maximum ratings” may cause permanent damage to the device. These are stress ratings only, and functional operation of the device at these or any other conditions beyond those indicated under “recommended operating conditions” is not implied. Exposure to absolute-maximum-rated conditions for extended periods may affect device reliability.

- NOTES: 1. All voltage values are with respect to GND.
2. Differential input voltage is measured at the noninverting input with respect to the corresponding inverting input.

DISSIPATION RATING TABLE

PACKAGE	$T_A \leq 25^\circ\text{C}$ POWER RATING	DERATING FACTOR ABOVE $T_A = 25^\circ\text{C}$	$T_A = 125^\circ\text{C}$ POWER RATING
FK	1375 mW	11.0 mW/°C	275 mW
J	1375 mW	11.0 mW/°C	275 mW
W	1000 mW	8.0 mW/°C	200 mW

recommended operating conditions

	MIN	NOM	MAX	UNIT
Supply voltage, V_{CC}	4.75	5	5.25	V
Common-mode input voltage, V_{IC}	–7		12	V
Differential input voltage, V_{ID}			±6	V
High-level input voltage, V_{IH}	2			V
Low-level input voltage, V_{IL}				0.8
High-level output current, I_{OH}			–8	mA
Low-level output current, I_{OL}			16	mA
Operating free-air temperature, T_A	–55		125	°C

SN55LBC173

QUADRUPLE LOW-POWER DIFFERENTIAL RECEIVER

SGLS081A – MARCH 1995 – REVISED JUNE 2000

electrical characteristics over recommended ranges of supply voltage and operating free-air temperature (unless otherwise noted)

PARAMETER		TEST CONDITIONS	MIN	TYP†	MAX	UNIT	
V_{IT+}	Positive-going input threshold voltage	$I_O = -8$ mA			0.2	V	
V_{IT-}	Negative-going input threshold voltage	$I_O = 8$ mA	-0.2			V	
V_{hys}	Hysteresis voltage ($V_{IT+} - V_{IT-}$)			45		mV	
V_{IK}	Enable input clamp voltage	$I_I = -18$ mA		-0.9	-1.5	V	
V_{OH}	High-level output voltage	$V_{ID} = 200$ mV, $I_{OH} = -8$ mA	3.5	4.5		V	
V_{OL}	Low-level output voltage	$V_{ID} = -200$ mV, $I_{OL} = 8$ mA		0.3	0.5	V	
		$V_{ID} = -200$ mV, $I_{OL} = 8$ mA, $T_A = 125^\circ\text{C}$			0.7		
I_{OZ}	High-impedance-state output current	$V_O = 0$ V to V_{CC}			± 20	μA	
I_I	Bus input current	A or B inputs	$V_{IH} = 12$ V, $V_{CC} = 5$ V, Other inputs at 0 V		0.7	1	mA
			$V_{IH} = 12$ V, $V_{CC} = 0$ V, Other inputs at 0 V		0.8	1	
			$V_{IH} = -7$ V, $V_{CC} = 5$ V, Other inputs at 0 V		-0.5	-0.8	
			$V_{IH} = -7$ V, $V_{CC} = 0$ V, Other inputs at 0 V		-0.4	-0.8	
I_{IH}	High-level input current	$V_{IH} = 5$ V			± 20	μA	
I_{IL}	Low-level input current	$V_{IL} = 0$ V			-20	μA	
I_{OS}	Short-circuit output current	$V_O = 0$			-80	-120	mA
I_{CC}	Supply current	Outputs enabled, $I_O = 0$, $V_{ID} = 5$ V			11	20	mA
		Outputs disabled			0.9	1.4	

† All typical values are at $V_{CC} = 5$ V and $T_A = 25^\circ\text{C}$.

switching characteristics, $V_{CC} = 5$ V, $C_L = 15$ pF

PARAMETER		TEST CONDITIONS	T_A	MIN	TYP	MAX	UNIT
t_{PHL}	Propagation delay time, high-to-low-level output	$V_{ID} = -1.5$ V to 1.5 V, See Figure 1	25°C	11	22	30	ns
			-55°C to 125°C	11		35	
t_{PLH}	Propagation delay time, low-to-high-level output	$V_{ID} = -1.5$ V to 1.5 V, See Figure 1	25°C	11	22	35	ns
			-55°C to 125°C	11		35	
t_{PZH}	Output enable time to high level	See Figure 2	25°C		17	40	ns
			-55°C to 125°C			45	
t_{PZL}	Output enable time to low level	See Figure 3	25°C		18	30	ns
			-55°C to 125°C			35	
t_{PHZ}	Output disable time from high level	See Figure 2	25°C		30	40	ns
			-55°C to 125°C			55	
t_{PLZ}	Output disable time from low level	See Figure 3	25°C		25	40	ns
			-55°C to 125°C			45	
$t_{sk(p)}$	Pulse skew ($t_{PHL} - t_{PLH}$)	See Figure 1	25°C		0.5	6	ns
			-55°C to 125°C			7	
t_t	Transition time	See Figure 1	25°C		5	10	ns
			-55°C to 125°C			16	



PARAMETER MEASUREMENT INFORMATION

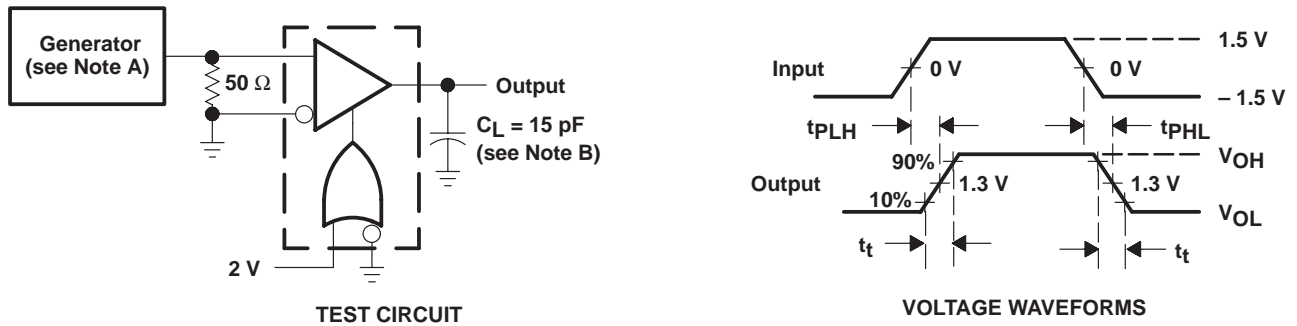

- NOTES: A. The input pulse is supplied by a generator having the following characteristics: PRR = 1 MHz, duty cycle \leq 50%, $t_r \leq$ 6 ns, $t_f \leq$ 6 ns, $Z_O = 50 \Omega$.
 B. C_L includes probe and jig capacitance.

Figure 1. t_{pd} and t_f Test Circuit and Voltage Waveforms

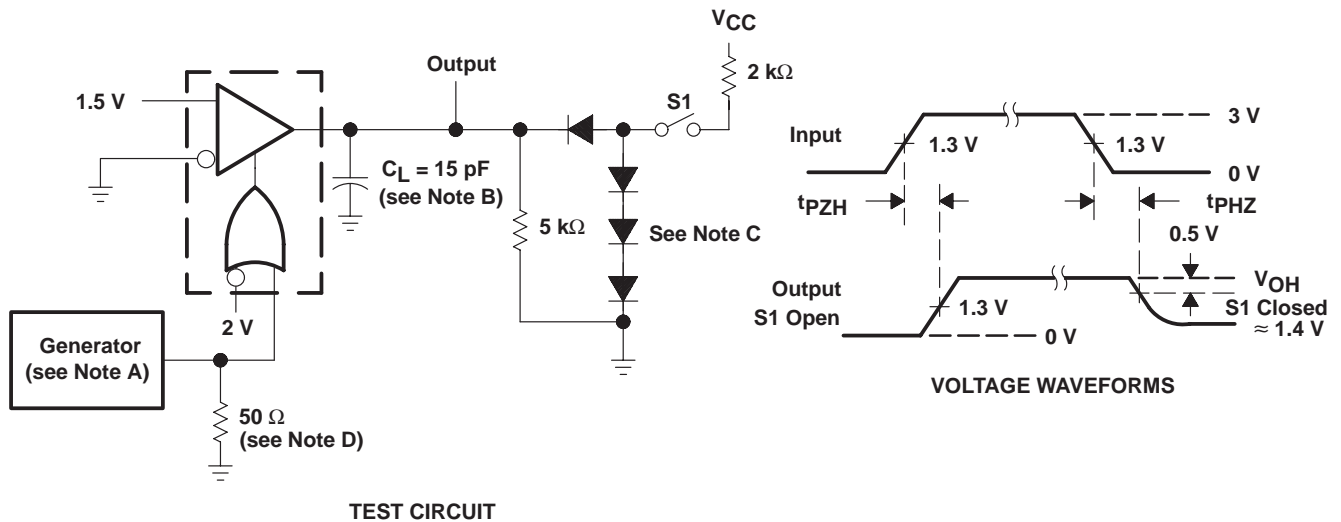

- NOTES: A. The input pulse is supplied by a generator having the following characteristics: PRR = 1 MHz, duty cycle \leq 50%, $t_r \leq$ 6 ns, $t_f \leq$ 6 ns, $Z_O = 50 \Omega$.
 B. C_L includes probe and jig capacitance.
 C. All diodes are 1N916 or equivalent.
 D. To test the active-low enable \overline{G} , ground G and apply an inverted input waveform to \overline{G} .

Figure 2. t_{pZH} and t_{pZH} Test Circuit and Voltage Waveforms

SN55LBC173 QUADRUPLE LOW-POWER DIFFERENTIAL RECEIVER

SGLS081A – MARCH 1995 – REVISED JUNE 2000

PARAMETER MEASUREMENT INFORMATION

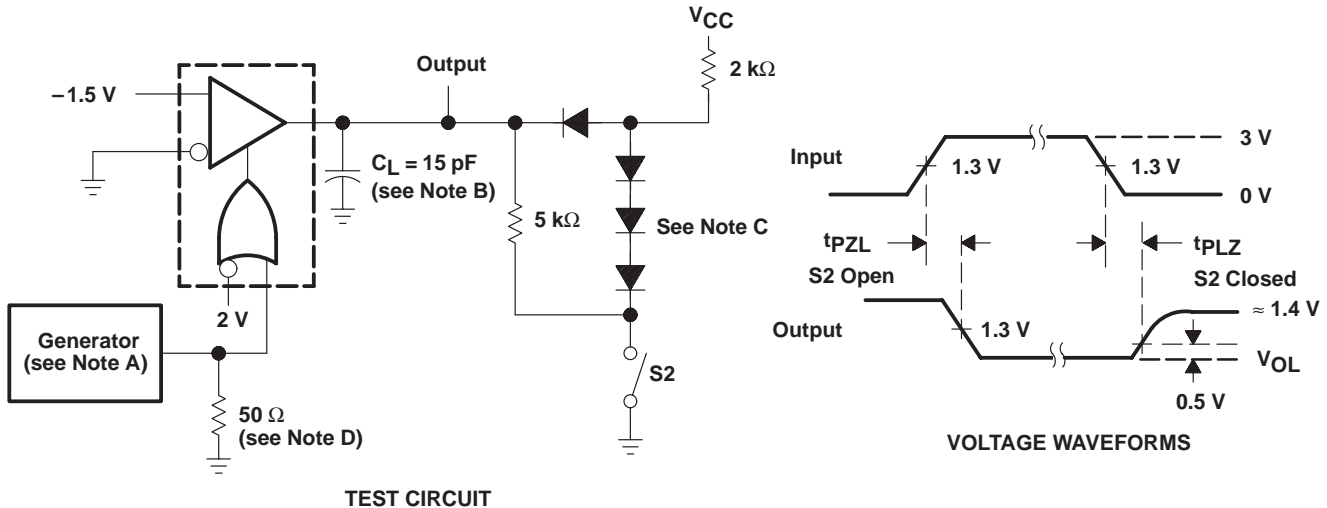

- NOTES: A. The input pulse is supplied by a generator having the following characteristics: PRR = 1 MHz, duty cycle \leq 50%, $t_r \leq$ 6 ns, $t_f \leq$ 6 ns, $Z_O = 50 \Omega$.
 B. C_L includes probe and jig capacitance.
 C. All diodes are 1N916 or equivalent.
 D. To test the active-low enable \bar{G} , ground G and apply an inverted input waveform to \bar{G} .

Figure 3. t_{pZL} and t_{pLZ} Test Circuit and Voltage Waveforms

TYPICAL CHARACTERISTICS

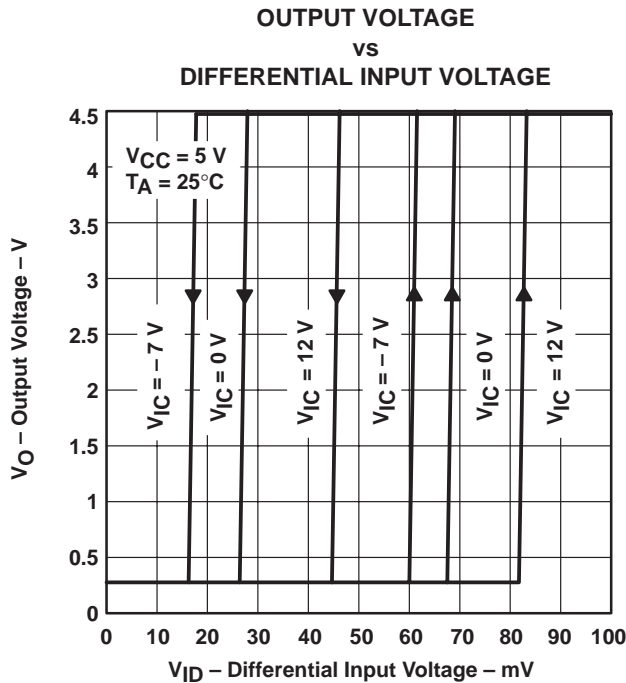

Figure 4

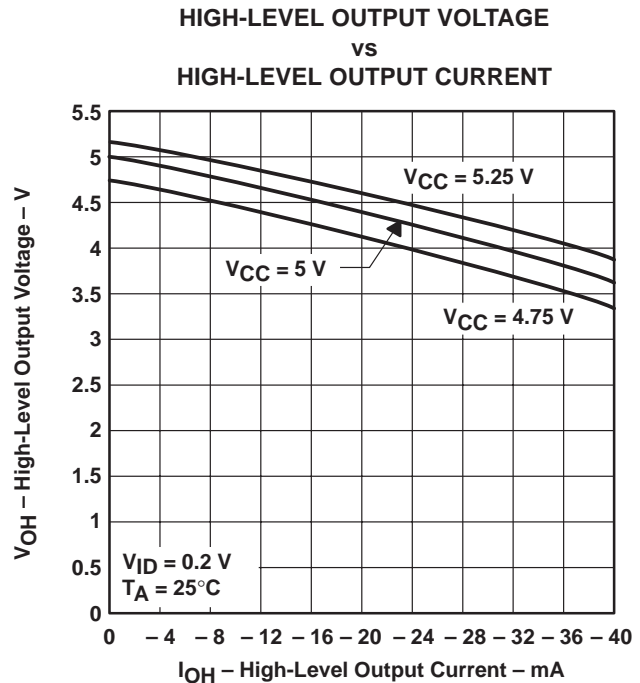

Figure 5

TYPICAL CHARACTERISTICS

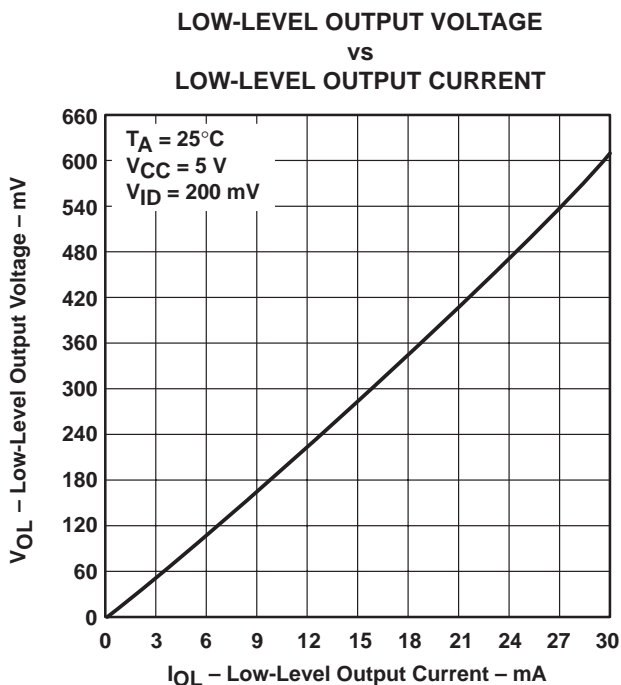

Figure 6

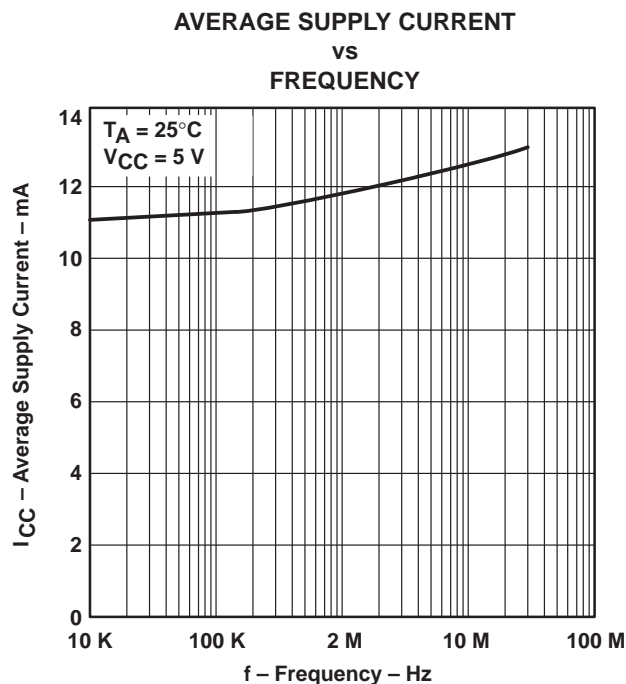

Figure 7

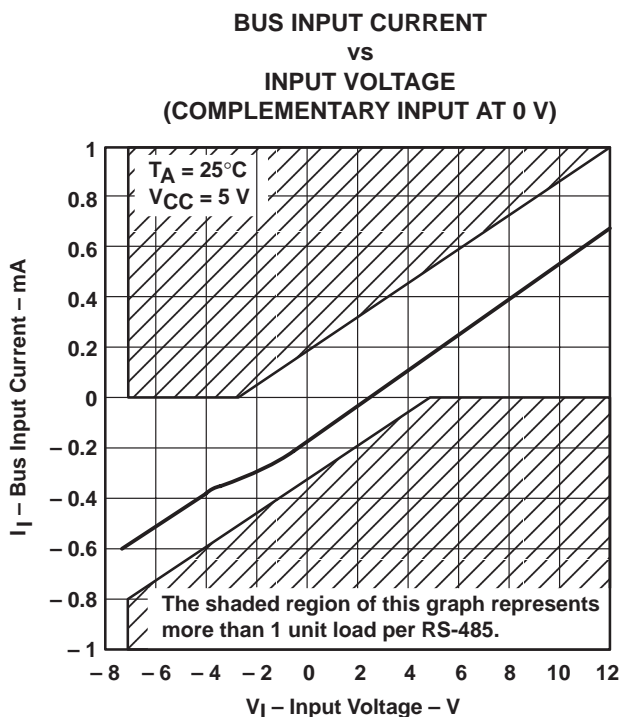

Figure 8

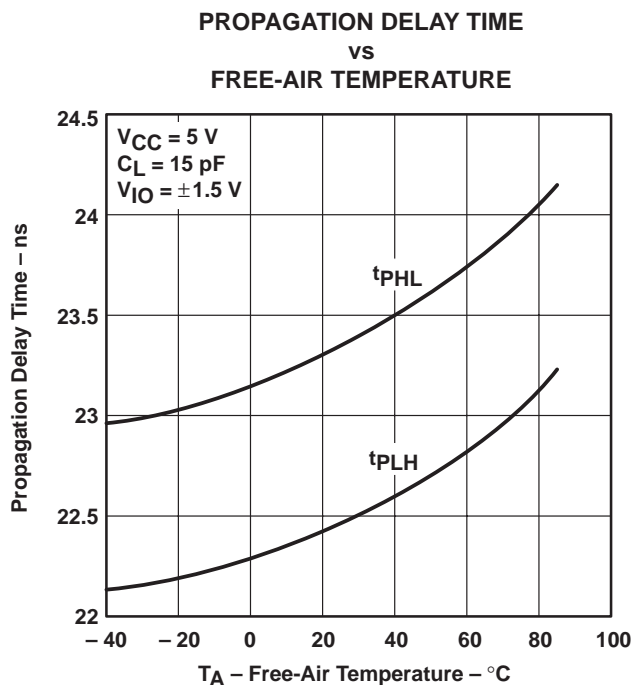

Figure 9

PACKAGING INFORMATION

Orderable Device	Status (1)	Package Type	Package Drawing	Pins	Package Qty	Eco Plan (2)	Lead/Ball Finish (6)	MSL Peak Temp (3)	Op Temp (°C)	Device Marking (4/5)	Samples
5962-9076604Q2A	ACTIVE	LCCC	FK	20	1	TBD	POST-PLATE	N / A for Pkg Type	-55 to 125	5962- 9076604Q2A SNJ55 LBC173FK	Samples
5962-9076604QEA	ACTIVE	CDIP	J	16	1	TBD	A42	N / A for Pkg Type	-55 to 125	5962-9076604QE A SNJ55LBC173J	Samples
5962-9076604QFA	ACTIVE	CFP	W	16	1	TBD	A42	N / A for Pkg Type	-55 to 125	5962-9076604QF A SNJ55LBC173W	Samples
SNJ55LBC173FK	ACTIVE	LCCC	FK	20	1	TBD	POST-PLATE	N / A for Pkg Type	-55 to 125	5962- 9076604Q2A SNJ55 LBC173FK	Samples
SNJ55LBC173J	ACTIVE	CDIP	J	16	1	TBD	A42	N / A for Pkg Type	-55 to 125	5962-9076604QE A SNJ55LBC173J	Samples
SNJ55LBC173W	ACTIVE	CFP	W	16	1	TBD	A42	N / A for Pkg Type	-55 to 125	5962-9076604QF A SNJ55LBC173W	Samples

(1) The marketing status values are defined as follows:

ACTIVE: Product device recommended for new designs.

LIFEBUY: TI has announced that the device will be discontinued, and a lifetime-buy period is in effect.

NRND: Not recommended for new designs. Device is in production to support existing customers, but TI does not recommend using this part in a new design.

PREVIEW: Device has been announced but is not in production. Samples may or may not be available.

OBSOLETE: TI has discontinued the production of the device.

(2) Eco Plan - The planned eco-friendly classification: Pb-Free (RoHS), Pb-Free (RoHS Exempt), or Green (RoHS & no Sb/Br) - please check <http://www.ti.com/productcontent> for the latest availability information and additional product content details.

TBD: The Pb-Free/Green conversion plan has not been defined.

Pb-Free (RoHS): TI's terms "Lead-Free" or "Pb-Free" mean semiconductor products that are compatible with the current RoHS requirements for all 6 substances, including the requirement that lead not exceed 0.1% by weight in homogeneous materials. Where designed to be soldered at high temperatures, TI Pb-Free products are suitable for use in specified lead-free processes.

Pb-Free (RoHS Exempt): This component has a RoHS exemption for either 1) lead-based flip-chip solder bumps used between the die and package, or 2) lead-based die adhesive used between the die and leadframe. The component is otherwise considered Pb-Free (RoHS compatible) as defined above.

Green (RoHS & no Sb/Br): TI defines "Green" to mean Pb-Free (RoHS compatible), and free of Bromine (Br) and Antimony (Sb) based flame retardants (Br or Sb do not exceed 0.1% by weight in homogeneous material)

- (3) MSL, Peak Temp. - The Moisture Sensitivity Level rating according to the JEDEC industry standard classifications, and peak solder temperature.
- (4) There may be additional marking, which relates to the logo, the lot trace code information, or the environmental category on the device.
- (5) Multiple Device Markings will be inside parentheses. Only one Device Marking contained in parentheses and separated by a "-" will appear on a device. If a line is indented then it is a continuation of the previous line and the two combined represent the entire Device Marking for that device.
- (6) Lead/Ball Finish - Orderable Devices may have multiple material finish options. Finish options are separated by a vertical ruled line. Lead/Ball Finish values may wrap to two lines if the finish value exceeds the maximum column width.

Important Information and Disclaimer:The information provided on this page represents TI's knowledge and belief as of the date that it is provided. TI bases its knowledge and belief on information provided by third parties, and makes no representation or warranty as to the accuracy of such information. Efforts are underway to better integrate information from third parties. TI has taken and continues to take reasonable steps to provide representative and accurate information but may not have conducted destructive testing or chemical analysis on incoming materials and chemicals. TI and TI suppliers consider certain information to be proprietary, and thus CAS numbers and other limited information may not be available for release.

In no event shall TI's liability arising out of such information exceed the total purchase price of the TI part(s) at issue in this document sold by TI to Customer on an annual basis.

OTHER QUALIFIED VERSIONS OF SN55LBC173 :

- Catalog: [SN75LBC173](#)

NOTE: Qualified Version Definitions:

- Catalog - TI's standard catalog product

J (R-GDIP-T**)

14 LEADS SHOWN

CERAMIC DUAL IN-LINE PACKAGE



DIM \ PINS **	14	16	18	20
A	0.300 (7,62) BSC	0.300 (7,62) BSC	0.300 (7,62) BSC	0.300 (7,62) BSC
B MAX	0.785 (19,94)	.840 (21,34)	0.960 (24,38)	1.060 (26,92)
B MIN	—	—	—	—
C MAX	0.300 (7,62)	0.300 (7,62)	0.310 (7,87)	0.300 (7,62)
C MIN	0.245 (6,22)	0.245 (6,22)	0.220 (5,59)	0.245 (6,22)



4040083/F 03/03

- NOTES:
- All linear dimensions are in inches (millimeters).
 - This drawing is subject to change without notice.
 - This package is hermetically sealed with a ceramic lid using glass frit.
 - Index point is provided on cap for terminal identification only on press ceramic glass frit seal only.
 - Falls within MIL STD 1835 GDIP1-T14, GDIP1-T16, GDIP1-T18 and GDIP1-T20.

W (R-GDFP-F16)

CERAMIC DUAL FLATPACK

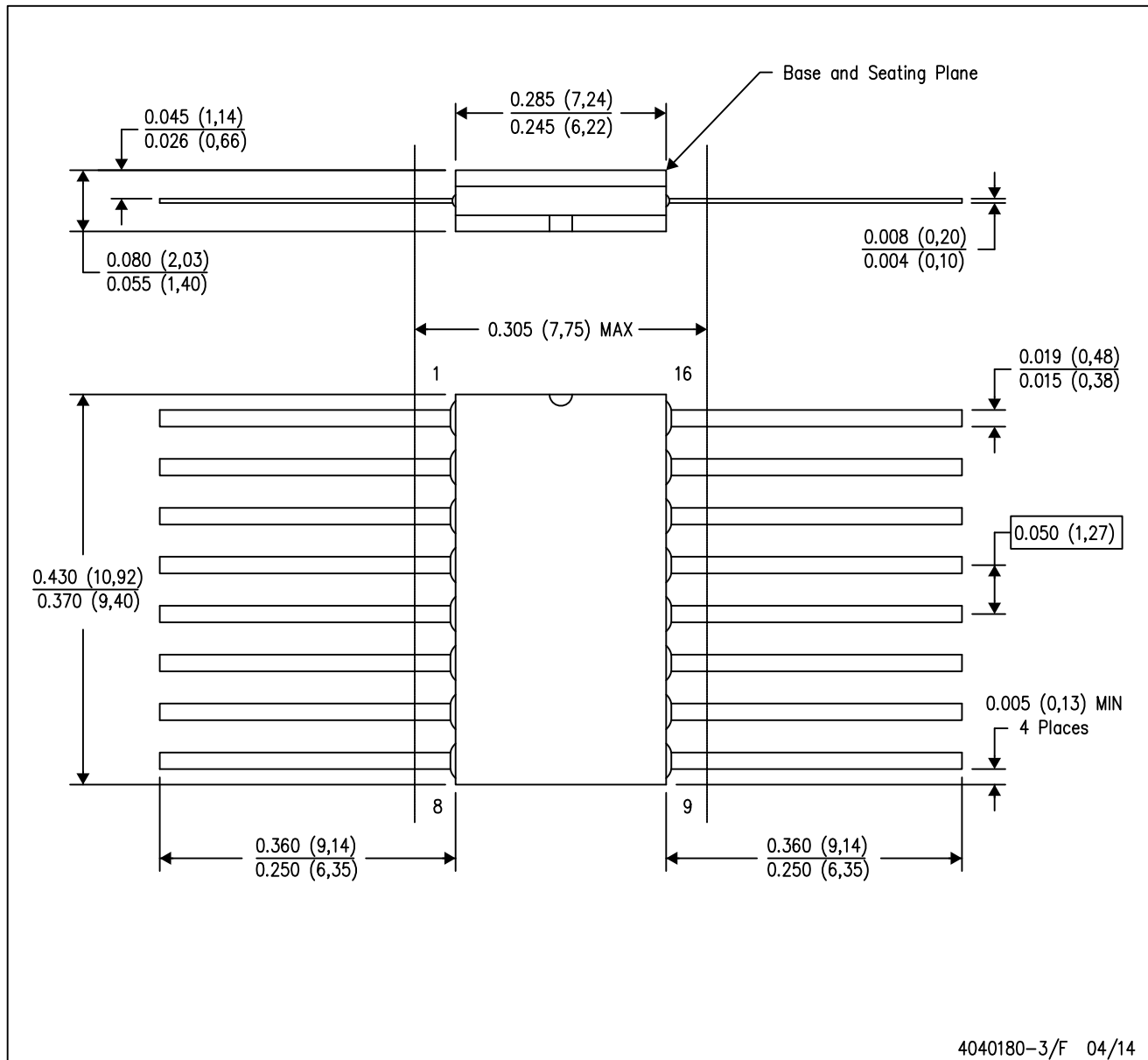

- NOTES:
- A. All linear dimensions are in inches (millimeters).
 - B. This drawing is subject to change without notice.
 - C. This package can be hermetically sealed with a ceramic lid using glass frit.
 - D. Index point is provided on cap for terminal identification only.
 - E. Falls within MIL STD 1835 GDFP2-F16

FK (S-CQCC-N**)

LEADLESS CERAMIC CHIP CARRIER

28 TERMINAL SHOWN



NO. OF TERMINALS **	A		B	
	MIN	MAX	MIN	MAX
20	0.342 (8,69)	0.358 (9,09)	0.307 (7,80)	0.358 (9,09)
28	0.442 (11,23)	0.458 (11,63)	0.406 (10,31)	0.458 (11,63)
44	0.640 (16,26)	0.660 (16,76)	0.495 (12,58)	0.560 (14,22)
52	0.740 (18,78)	0.761 (19,32)	0.495 (12,58)	0.560 (14,22)
68	0.938 (23,83)	0.962 (24,43)	0.850 (21,6)	0.858 (21,8)
84	1.141 (28,99)	1.165 (29,59)	1.047 (26,6)	1.063 (27,0)



4040140/D 01/11

- NOTES:
- All linear dimensions are in inches (millimeters).
 - This drawing is subject to change without notice.
 - This package can be hermetically sealed with a metal lid.
 - Falls within JEDEC MS-004

IMPORTANT NOTICE

Texas Instruments Incorporated and its subsidiaries (TI) reserve the right to make corrections, enhancements, improvements and other changes to its semiconductor products and services per JESD46, latest issue, and to discontinue any product or service per JESD48, latest issue. Buyers should obtain the latest relevant information before placing orders and should verify that such information is current and complete. All semiconductor products (also referred to herein as "components") are sold subject to TI's terms and conditions of sale supplied at the time of order acknowledgment.

TI warrants performance of its components to the specifications applicable at the time of sale, in accordance with the warranty in TI's terms and conditions of sale of semiconductor products. Testing and other quality control techniques are used to the extent TI deems necessary to support this warranty. Except where mandated by applicable law, testing of all parameters of each component is not necessarily performed.

TI assumes no liability for applications assistance or the design of Buyers' products. Buyers are responsible for their products and applications using TI components. To minimize the risks associated with Buyers' products and applications, Buyers should provide adequate design and operating safeguards.

TI does not warrant or represent that any license, either express or implied, is granted under any patent right, copyright, mask work right, or other intellectual property right relating to any combination, machine, or process in which TI components or services are used. Information published by TI regarding third-party products or services does not constitute a license to use such products or services or a warranty or endorsement thereof. Use of such information may require a license from a third party under the patents or other intellectual property of the third party, or a license from TI under the patents or other intellectual property of TI.

Reproduction of significant portions of TI information in TI data books or data sheets is permissible only if reproduction is without alteration and is accompanied by all associated warranties, conditions, limitations, and notices. TI is not responsible or liable for such altered documentation. Information of third parties may be subject to additional restrictions.

Resale of TI components or services with statements different from or beyond the parameters stated by TI for that component or service voids all express and any implied warranties for the associated TI component or service and is an unfair and deceptive business practice. TI is not responsible or liable for any such statements.

Buyer acknowledges and agrees that it is solely responsible for compliance with all legal, regulatory and safety-related requirements concerning its products, and any use of TI components in its applications, notwithstanding any applications-related information or support that may be provided by TI. Buyer represents and agrees that it has all the necessary expertise to create and implement safeguards which anticipate dangerous consequences of failures, monitor failures and their consequences, lessen the likelihood of failures that might cause harm and take appropriate remedial actions. Buyer will fully indemnify TI and its representatives against any damages arising out of the use of any TI components in safety-critical applications.

In some cases, TI components may be promoted specifically to facilitate safety-related applications. With such components, TI's goal is to help enable customers to design and create their own end-product solutions that meet applicable functional safety standards and requirements. Nonetheless, such components are subject to these terms.

No TI components are authorized for use in FDA Class III (or similar life-critical medical equipment) unless authorized officers of the parties have executed a special agreement specifically governing such use.

Only those TI components which TI has specifically designated as military grade or "enhanced plastic" are designed and intended for use in military/aerospace applications or environments. Buyer acknowledges and agrees that any military or aerospace use of TI components which have **not** been so designated is solely at the Buyer's risk, and that Buyer is solely responsible for compliance with all legal and regulatory requirements in connection with such use.

TI has specifically designated certain components as meeting ISO/TS16949 requirements, mainly for automotive use. In any case of use of non-designated products, TI will not be responsible for any failure to meet ISO/TS16949.

Products

Audio	www.ti.com/audio
Amplifiers	amplifier.ti.com
Data Converters	dataconverter.ti.com
DLP® Products	www.dlp.com
DSP	dsp.ti.com
Clocks and Timers	www.ti.com/clocks
Interface	interface.ti.com
Logic	logic.ti.com
Power Mgmt	power.ti.com
Microcontrollers	microcontroller.ti.com
RFID	www.ti-rfid.com
OMAP Applications Processors	www.ti.com/omap
Wireless Connectivity	www.ti.com/wirelessconnectivity

Applications

Automotive and Transportation	www.ti.com/automotive
Communications and Telecom	www.ti.com/communications
Computers and Peripherals	www.ti.com/computers
Consumer Electronics	www.ti.com/consumer-apps
Energy and Lighting	www.ti.com/energy
Industrial	www.ti.com/industrial
Medical	www.ti.com/medical
Security	www.ti.com/security
Space, Avionics and Defense	www.ti.com/space-avionics-defense
Video and Imaging	www.ti.com/video

TI E2E Community

e2e.ti.com