

Distributed by:

JAMECO[®]
ELECTRONICS

www.Jameco.com ♦ 1-800-831-4242

The content and copyrights of the attached
material are the property of its owner.

Jameco Part Number 1114018

TPS60140, TPS60141 LOW POWER DC-DC CONVERTER REGULATED 5 V, 100-mA CHARGE PUMP VOLTAGE TRIPLER

SLVS273– FEBRUARY 2000

features

- Regulated 5 V \pm 4% Output Voltage With up to 100 mA Output Current From a 1.8 V to 3.6 V Input Voltage Range
- 65- μ A Quiescent Supply Current
- 0.05- μ A Shutdown Current, Battery Is Isolated From Load in Shutdown
- Integrated Low-Battery or Power-Good Indicator
- Low Output Voltage Ripple Over Complete Output Current Range
- Easy-To-Design With Low-EMI Power Supply Since no Inductors Are Required
- Evaluation Module Available (TPS60140EVM-144)

description

The TPS6014x step-up, regulated charge pumps generate a 5-V \pm 4% output voltage from a 1.8 V to 3.6 V input voltage range. The devices are typically powered by two alkaline, NiCd, or NiMH battery cells and provide an output current of minimum 100 mA from a 2-V input. Only four external capacitors are needed to build a complete voltage tripler charge pump.

The devices regulate the output by using the pulse-skip topology. The controller is optimized for lowest output voltage ripple over the complete output current range. The output peak current and therefore the output voltage ripple are drastically reduced compared to a conventional pulse-skip topology by regulating the charge pump output resistance. At light loads the maximum output resistance is limited to assure a low quiescent current.

The TPS60140 includes a low-battery comparator that issues a warning if the battery voltage drops below a user-adjustable threshold voltage. The TPS60141 features a power-good output that goes active when the output voltage reaches 90% of its nominal value.

The logic shutdown function disables the converter, reduces the supply current to a maximum of 1 μ A and disconnects the output from the input. Special current-control circuitry prevents excessive current from being drawn from the battery during start-up. This dc-dc converter requires no inductors, therefore, EMI is of little concern. It is available in the small, thermally enhanced 20-pin TSSOP package (PWP).

applications

- Replaces DC/DC Converters With Inductors in Battery-Powered Applications:
 - Two Battery Cells to 5 V Conversion
 - Portable Instruments
 - Miniature Equipment
 - Backup-Battery Boost Converters
 - Medical Instruments
 - 5-V Smart Card Supply
 - Organizers, PDAs

typical operating circuit

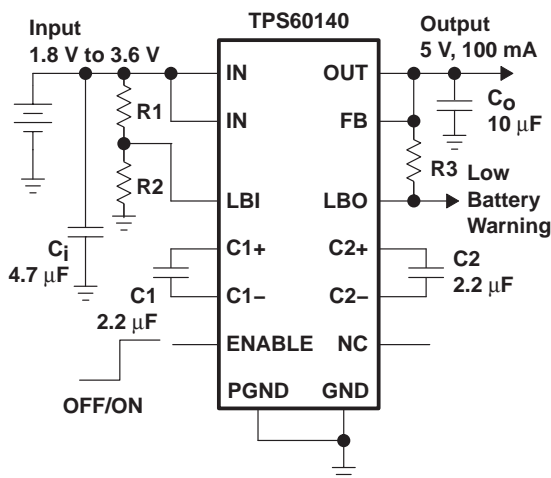

Please be aware that an important notice concerning availability, standard warranty, and use in critical applications of Texas Instruments semiconductor products and disclaimers thereto appears at the end of this data sheet.

PowerPAD is a trademark of Texas Instruments Incorporated.

PRODUCTION DATA information is current as of publication date. Products conform to specifications per the terms of Texas Instruments standard warranty. Production processing does not necessarily include testing of all parameters.



POST OFFICE BOX 655303 • DALLAS, TEXAS 75265

Copyright © 2000, Texas Instruments Incorporated

TPS60140, TPS60141

LOW POWER DC-DC CONVERTER

REGULATED 5 V, 100-mA CHARGE PUMP VOLTAGE TRIPLER

SLVS273– FEBRUARY 2000

AVAILABLE OPTIONS

TA	PART NUMBER†	PACKAGE		DEVICE FEATURES	
–40°C to 85°C	TPS60140PWP	PWP	20-pin thermally enhanced TSSOP	2-cell to 5 V, 100 mA	Low-battery detector
	TPS60141PWP				Power-good detector

† The PWP package is available taped and reeled. Add an R suffix to the device type (e.g. TPS60140PWPR) to order quantities of 2000 devices per reel.

PWP PACKAGE (TPS60140)
(TOP VIEW)

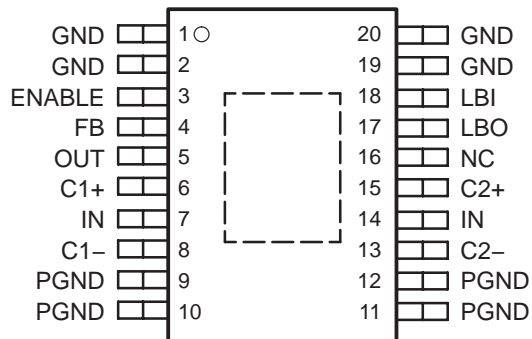

PWP PACKAGE (TPS60141)
(TOP VIEW)

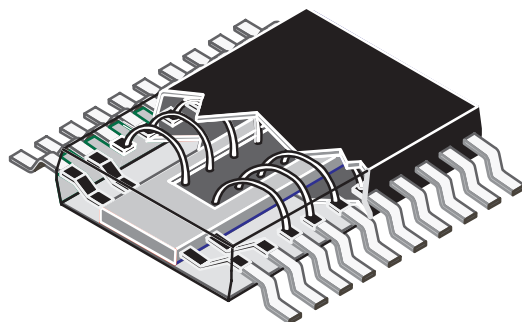
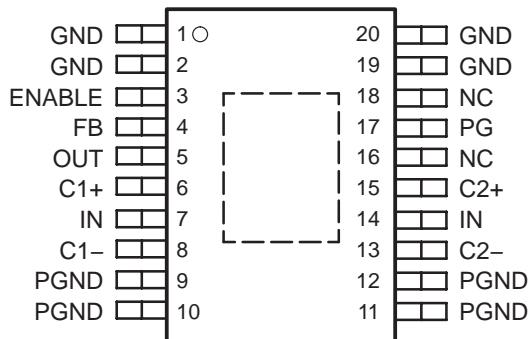

TPS60140, TPS60141
LOW POWER DC-DC CONVERTER
REGULATED 5 V, 100-mA CHARGE PUMP VOLTAGE TRIPLER

SLVS273– FEBRUARY 2000

functional block diagrams

TPS60140

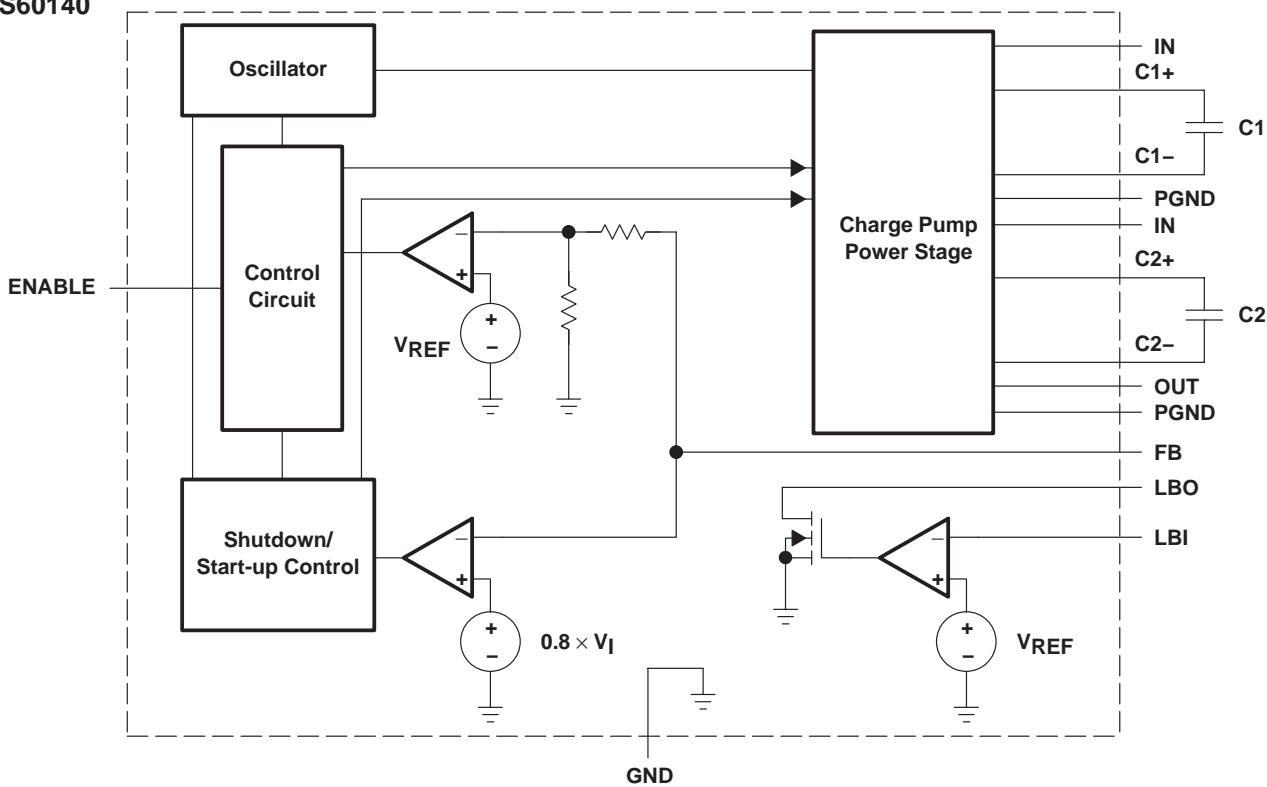

TPS60141

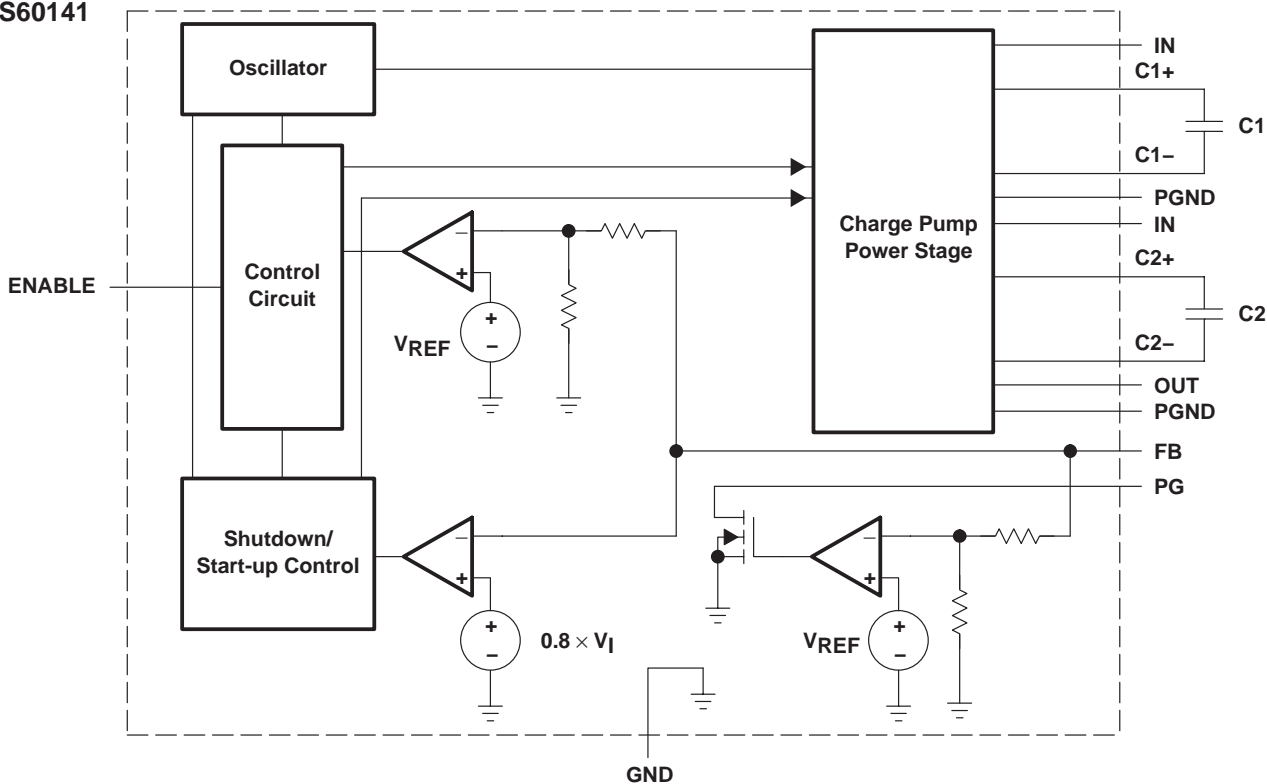

TPS60140, TPS60141
LOW POWER DC-DC CONVERTER
REGULATED 5 V, 100-mA CHARGE PUMP VOLTAGE TRIPLER
 SLVS273– FEBRUARY 2000

Terminal Functions

TERMINAL NAME	NO.	I/O	DESCRIPTION
C1+	6		Positive terminal of the flying capacitor C1
C1–	8		Negative terminal of the flying capacitor C1
C2+	15		Positive terminal of the flying capacitor C2
C2–	13		Negative terminal of the flying capacitor C2
ENABLE	3	I	ENABLE input. Connect ENABLE to IN for normal operation. When ENABLE is a logic low, the device turns off and the supply current decreases to 0.05 μ A. The output is disconnected from the input when the device is placed in shutdown.
FB	4	I	Feedback input. Connect FB to OUT as close to the load as possible to achieve best regulation. A resistive divider is on the chip to match the output voltage to the internal reference voltage of 1.21 V.
GND	1, 2, 19, 20		Ground. Analog ground for internal reference and control circuitry. Connect to PGND through a short trace.
IN	7, 14	I	Supply input. Bypass IN to PGND with capacitor C_i . Connect both IN terminals through a short trace.
LBO/PG	17	O	Low battery detector output (TPS60140) or power good output (TPS60141). Open drain output of the low-battery indicator or power-good comparator. It can sink 1 mA. A 100-k Ω to 1-M Ω pullup is recommended. Leave the terminal unconnected if the low-battery or power-good detector function is not used.
LBI/NC	18	I	Low battery detector input (TPS60140 only). The voltage applied to this terminal is compared to the internal 1.21-V reference voltage. Connect the terminal to ground if the low-battery comparator is not used. On the TPS60141, this terminal is not connected to the chip and should remain unconnected.
NC	16		Not connected
OUT	5	O	Regulated 5-V power output. Bypass OUT to PGND with the output filter capacitor C_o .
PGND	9–12		Power ground. The charge-pump current flows through this terminal. Connect all PGND terminals together.

detailed description

The TPS6014x charge pumps provide a regulated 5-V output from a 1.8-V to 3.6-V input voltage range. They can deliver a maximum continuous load current of at least 100 mA at $V_i = 2$ V minimum. Designed specifically for space-critical battery-powered applications, the complete charge pump circuit requires only four external capacitors.

The TPS6014x consist of an oscillator, a 1.21-V voltage reference, an internal resistive feedback circuit, an error amplifier, high current MOSFET switches, a shutdown/start-up circuit, a low-battery or power-good comparator and a control circuit (see the functional block diagrams).

operating principle

The TPS6014x devices regulate the output voltage using an improved pulse-skip topology. In pulse-skip mode the error amplifier disables switching of the power stages when it detects an output voltage higher than 5 V. The oscillator halts and the controller skips switching cycles. The error amplifier reactivates the oscillator and starts switching of the power stages again when the output voltage drops below 5 V. The output resistance of the charge pump is controlled to improve the ripple performance. This limits the output current to the minimum that is necessary to sustain a regulated output voltage. The benefit is that the ripple performance is nearly as good as with a linear-regulation topology.

At light loads a conventional pulse-skip regulation mode is used, but the charge pump output resistance is held at a high level. The pulse-skip regulation minimizes the operating current because the charge pump does not switch continuously and hence the gate-charge losses of the MOSFETs are reduced. Additionally, all functions except voltage reference, error amplifier, and low-battery or power-good comparator are deactivated when the output is higher than 5 V. When switching is disabled by the error amplifier, the load is also isolated from the input. This improved pulse-skip control topology is also referred to as *active-cycle* control.



detailed description (continued)

start-up procedure and shutdown

During start-up, i.e., when ENABLE is set from logic low to logic high, the output capacitor is charged up with a limited current until the output voltage(V_O) reaches $0.8 \times V_I$. When the start-up comparator detects this voltage limit, the IC begins switching. This pre-charging of the output capacitor ensures a short start-up time. In addition, the inrush current into an empty output capacitor is limited because the current through the switches is limited before the charge pump starts switching.

Driving ENABLE low places the device in shutdown mode. This disables all switches, the oscillator, and control logic. The device typically draws $0.05 \mu\text{A}$ of supply current in this mode. Leakage current drawn from the output is as low as $1 \mu\text{A}$ max. The device exits shutdown once ENABLE is set to a high level. When the device is in shutdown, the load is isolated from the input.

undervoltage lockout and short-circuit protection

The TPS6014x devices have an undervoltage lockout feature that deactivates the device and places it in shutdown mode when the input voltage falls below 1.6 V. The devices are also short-circuit protected. The output current is limited to typically 100 mA during a hard short circuit condition at the output, i.e., when V_O is GND. In this case the condition to enter the start-up mode is met, the device stops switching and controls the on-resistance of the appropriate MOSFET switches to limit the current.

low-battery detector (TPS60140 only)

The internal low-battery comparator trips at $1.21 \text{ V} \pm 5\%$ when the voltage on pin LBI ramps down. The voltage $V_{(\text{TRIP})}$ at which the low battery warning is issued can be adjusted with a resistive divider as shown in Figure 1. The sum of resistors R1 and R2 is recommended to be in the 100 k Ω to 1 M Ω range. When choosing R1 and R2, be aware of the input leakage current into the LBI terminal.

LBO is an open drain output. An external pullup resistor to OUT, in the 100 k Ω to 1 M Ω range, is recommended. During start-up, the LBO output signal is invalid for the first 500 μs . LBO is high impedance when the device is disabled. If the low-battery comparator function is not used, connect LBI to ground and leave LBO unconnected.

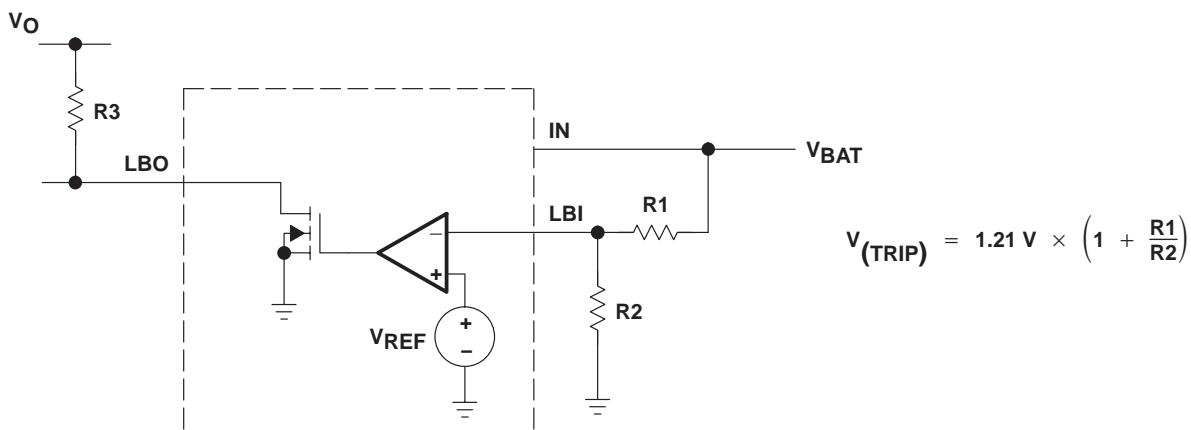

Figure 1. Programming of the Low-Battery Comparator Trip Voltage

A 100 nF ceramic capacitor should be connected in parallel to R2 if large line transients are expected. These voltage drops can inadvertently trigger the low-battery comparator and produce a wrong low-battery warning signal at the LBO pin.

TPS60140, TPS60141
LOW POWER DC-DC CONVERTER
REGULATED 5 V, 100-mA CHARGE PUMP VOLTAGE TRIPLER

SLVS273– FEBRUARY 2000

low-battery detector (TPS60140 only) (continued)

Formulas to calculate the resistive divider for low battery detection, with $V_{(LBI)} = 1.15\text{ V}$ to 1.27 V :

$$R2 = 1\text{ M}\Omega \times \frac{V_{LBI}}{V_{Bat}} \tag{1}$$

$$R1 = 1\text{ M}\Omega - R2 \tag{2}$$

Formulas to calculate the minimum and maximum trip voltage:

$$V_{\text{trip}(\text{min})} = V_{LBI(\text{min})} \times \frac{R1_{(\text{min})} + R2_{(\text{max})}}{R2_{(\text{max})}} \tag{3}$$

$$V_{\text{trip}(\text{max})} = V_{LBI(\text{max})} \times \frac{R1_{(\text{max})} + R2_{(\text{min})}}{R2_{(\text{min})}} \tag{4}$$

Table 1. Recommended Values for the Resistive Divider From the E96 Series ($\pm 1\%$)

V_I/V	R1/k Ω	R2/k Ω	$V_{(\text{TRIP})\text{MIN}}/V$	$V_{(\text{TRIP})\text{MAX}}/V$
1.8	357	732	1.700	1.902
1.9	365	634	1.799	2.016
2.0	412	634	1.883	2.112
2.1	432	590	1.975	2.219
2.2	442	536	2.080	2.338

power-good detector (TPS60141)

The PG terminal is an open-drain output that is pulled low when the output is out of regulation. When the output rises to typically 90% of its nominal voltage, the power-good output is released. Power-good is high impedance in shutdown. In normal operation an external pullup resistor must be connected between PG and OUT. The resistor should be in the 100 k Ω to 1 M Ω range. If the power-good function is not used, the PG terminal should remain unconnected.

absolute maximum ratings over operating free-air temperature range (unless otherwise noted)^{†‡}

Supply voltage range at IN to GND and PGND	–0.3 V to 3.6 V
Voltage range, at OUT, ENABLE, LBI, LBO, PG, FB to GND and PGND	–0.3 V to 5.4 V
Voltage range at C1+ TO GND	–0.3 V to ($V_O + 0.3\text{ V}$)
Voltage range at C1– TO GND	–0.3 V to ($V_I + 0.3\text{ V}$)
Voltage range at C2+ TO GND	–0.3 V to ($V_O + 0.3\text{ V}$)
Voltage range at C2– TO GND	–0.3 V to ($V_I + 0.3\text{ V}$)
Continuous output current	150 mA
Storage temperature range, T_{stg}	–55°C to 150°C
Lead temperature 1,6 mm (1/16 inch) from case for 10 seconds	260°C
Maximum junction temperature, T_J	150°C

[†] Stresses beyond those listed under “absolute maximum ratings” may cause permanent damage to the device. These are stress ratings only, and functional operation of the device at these or any other conditions beyond those indicated under “recommended operating conditions” is not implied. Exposure to absolute-maximum-rated conditions for extended periods may affect device reliability.

[‡] $V_{(\text{ENABLE})}$, $V_{(\text{LBI})}$, $V_{(\text{LBO})}$, and $V_{(\text{PG})}$ can exceed V_I up to the maximum rated voltage without increasing the leakage current drawn by these inputs.



TPS60140, TPS60141
LOW POWER DC-DC CONVERTER
REGULATED 5 V, 100-mA CHARGE PUMP VOLTAGE TRIPLER

SLVS273– FEBRUARY 2000

recommended operating conditions

	MIN	MAX	UNIT
Input voltage, V_I	1.8	3.6	V
Continuous output current, I_{Omax}		100	mA
Operating junction temperature, T_J		125	°C

electrical characteristics at $C_i = 4.7 \mu\text{F}$, $C_1 = C_2 = 2.2 \mu\text{F}$, $C_o = 10 \mu\text{F}^\dagger$ at $T_C = -40^\circ\text{C}$ to 85°C , $V_I = 2 \text{ V}$, $\text{FB} = V_O$ and $\text{ENABLE} = V_I$ (unless otherwise noted)

PARAMETER		TEST CONDITIONS	MIN	TYP	MAX	UNIT
$V_{(UVLO)}$	Undervoltage lockout threshold	$T_C = 25^\circ\text{C}$		1.6	1.8	V
I_{Omax}	Maximum continuous output current		100			mA
V_O	Output voltage	$1.8 \text{ V} < V_I < 2 \text{ V}$, V_O Start-up = 5 V, $0 < I_O < I_{Omax}/2$ $T_C = 0^\circ\text{C}$ to 70°C	4.8		5.2	V
		$2 \text{ V} < V_I < 3.6 \text{ V}$, $0 < I_O < I_{Omax}$	4.8		5.2	
$I_{lkg(OUT)}$	Output leakage current	$V_I = 2.4 \text{ V}$, $V_{(ENABLE)} = \text{GND}$			1	μA
I_Q	Quiescent current (no-load input current)	$V_I = 2.4 \text{ V}$		65	90	μA
$I_{(SD)}$	Shutdown current	$V_I = 2.4 \text{ V}$, $V_{(ENABLE)} = \text{GND}$		0.05	1	μA
$f_{(OSC)}$	Oscillator frequency		210	320	450	kHz
V_{IL}	ENABLE input voltage low	$V_I = 1.8 \text{ V}$			$0.3 \times V_I$	V
V_{IH}	ENABLE input voltage high	$V_I = 3.6 \text{ V}$	$0.7 \times V_I$			V
$I_{lkg(ENABLE)}$	ENABLE input leakage current	$V_{(ENABLE)} = \text{GND}$ or V_I		0.01	0.1	μA
	Output load regulation	$V_I = 2.4 \text{ V}$, $1 \text{ mA} < I_O < I_{Omax}$, $T_C = 25^\circ\text{C}$		0.003		%/mA
	Output line regulation	$2 \text{ V} < V_I < 3.6 \text{ V}$, $V_O = 5 \text{ V}$: $I_O = 75 \text{ mA}$, $T_C = 25^\circ\text{C}$		0.08		%/V
$I_{(SC)}$	Short circuit current limit	$V_I < 2.4 \text{ V}$, $V_O = 0 \text{ V}$, $T_C = 25^\circ\text{C}$		100		mA
$V_{(TRIP,LBI)}$	LBI trip voltage	TPS60140 $V_I = 1.8 \text{ V}$ to 2.2 V , Hysteresis 0.8% for rising LBI voltage, $T_C = 0^\circ\text{C}$ to 70°C	1.15	1.21	1.27	V
$I_{l(LBI)}$	LBI input current	TPS60140 $\text{LBI} = 1.3 \text{ V}$		20	100	nA
$V_{O(LBO)}$	LBO output voltage low ‡	TPS60140 $V_{(LBI)} = 0 \text{ V}$, $I_{(LBO,SINK)} = 1 \text{ mA}$			0.4	V
$I_{lkg(LBO)}$	LBO output leakage current	TPS60140 $V_{(LBI)} = 1.3 \text{ V}$, $V_{(LBO)} = 5 \text{ V}$		0.01	0.1	μA
$V_{(TRIP,PG)}$	Power-good trip voltage	TPS60141 $T_C = 0^\circ\text{C}$ to 70°C	$0.86 \times V_O$	$0.90 \times V_O$	$0.94 \times V_O$	V
$V_{hys(PG)}$	Power-good trip voltage hysteresis	TPS60141 V_O ramping down, $T_C = 0^\circ\text{C}$ to 70°C		0.8%		
$V_{O(PG)}$	Power-good output voltage low	TPS60141 $V_O = 0 \text{ V}$, $I_{(PG,SINK)} = 1 \text{ mA}$			0.4	V
$I_{lkg(PG)}$	Power-good leakage current	TPS60141 $V_O = 5 \text{ V}$, $V_{(PG)} = 5 \text{ V}$		0.01	0.1	μA

† All capacitors are ceramic capacitors of the type X5R or X7R.

‡ During start-up the LBO signal is invalid for the first 500 μs .



TPS60140, TPS60141
LOW POWER DC-DC CONVERTER
REGULATED 5 V, 100-mA CHARGE PUMP VOLTAGE TRIPLER

SLVS273– FEBRUARY 2000

PARAMETER MEASUREMENT INFORMATION

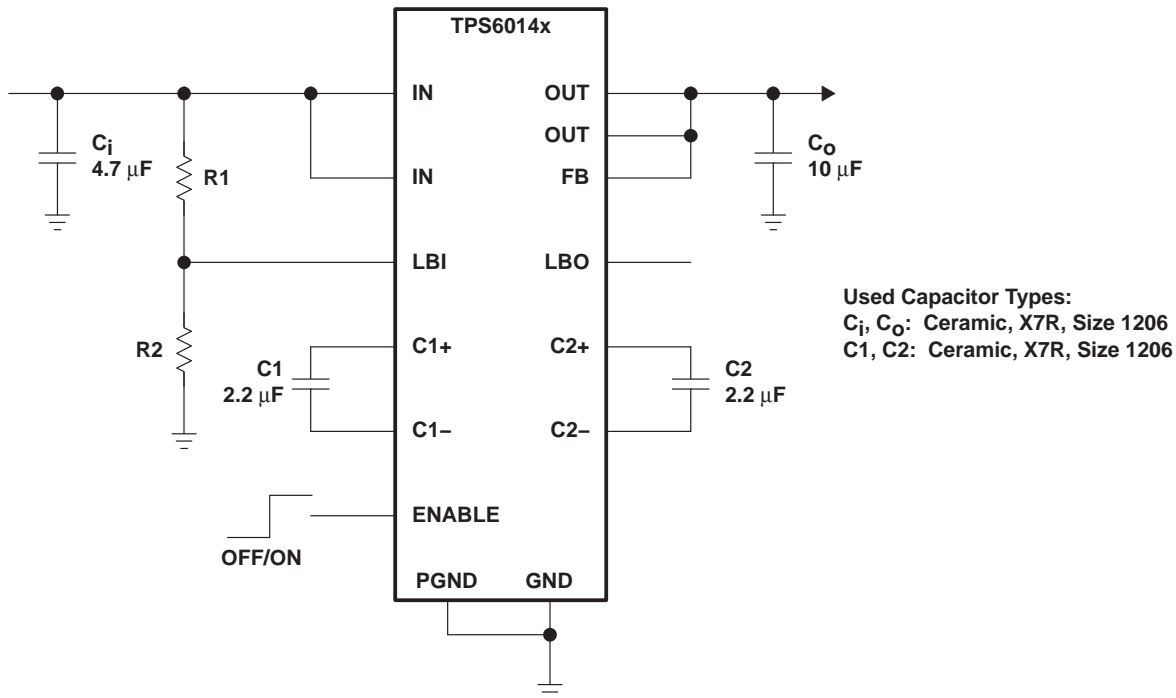

Figure 2. Circuit Used For Typical Characteristics Measurements

TYPICAL CHARACTERISTICS

Table of Graphs

			FIGURE
η	Efficiency	vs Output Current	3
		vs Input Voltage	4
I_Q	Quiescent Supply Current	vs Input Voltage	5
V_O	Output Voltage	vs Output Current	6
		vs Input Voltage	7
V_O	Output Voltage Ripple		8,9,10
V_{PP}	Output Voltage Ripple Amplitude	vs Input Voltage	11
		vs Output Current	12
$f_{(OSC)}$	Oscillator Frequency	vs Input Voltage	13
	Load Transient Response		14
	Line Transient Response		15
V_O	Output Voltage	vs Time (Start-up Timing)	16

TYPICAL CHARACTERISTICS

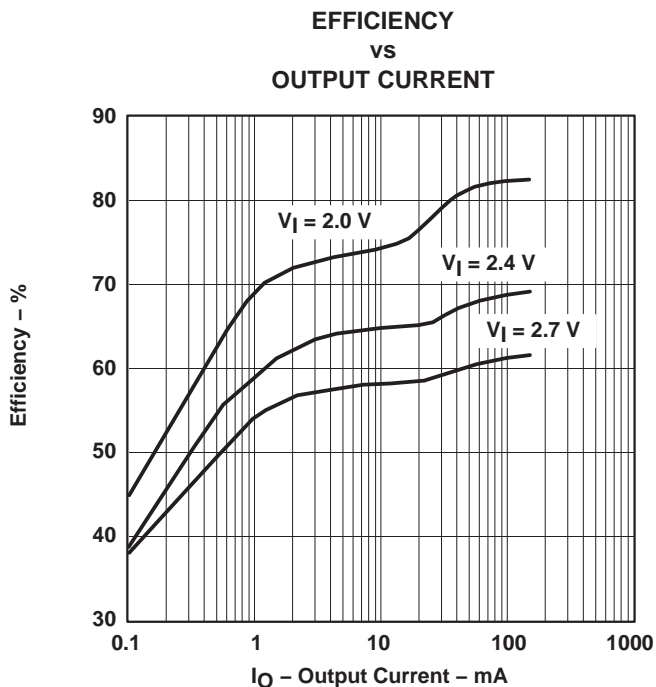

Figure 3

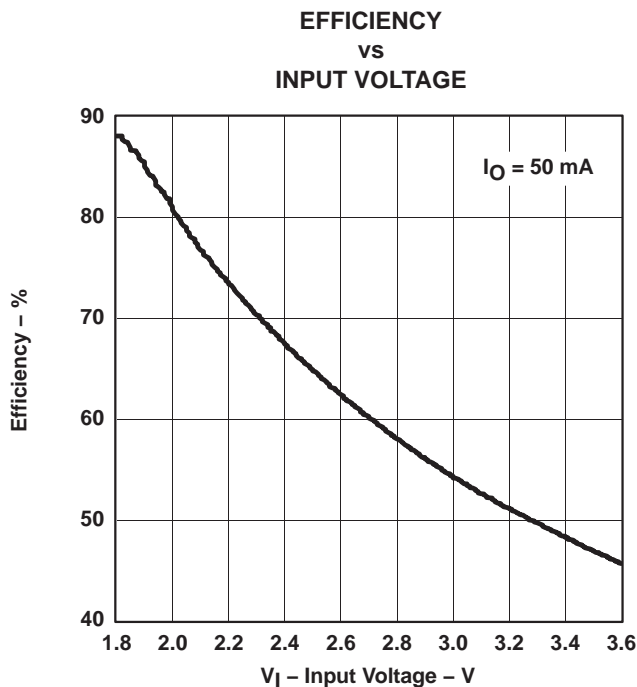

Figure 4

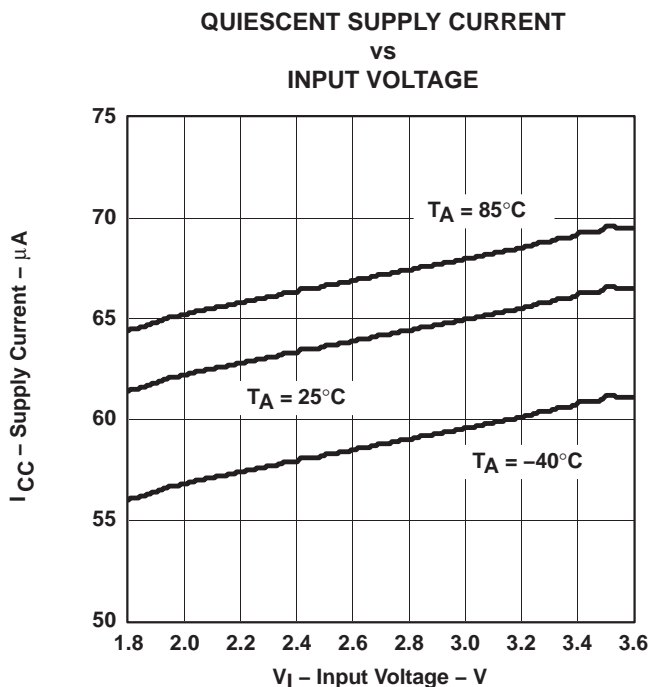

Figure 5

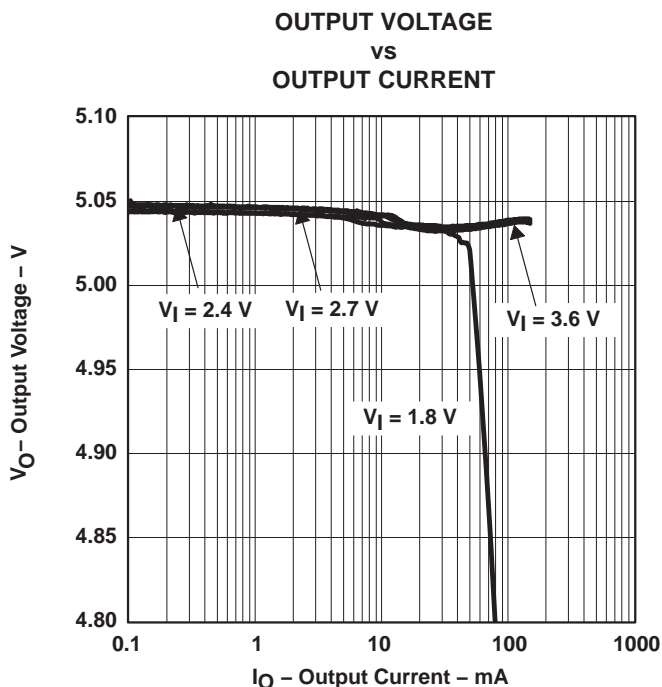

Figure 6

TPS60140, TPS60141
LOW POWER DC-DC CONVERTER
REGULATED 5 V, 100-mA CHARGE PUMP VOLTAGE TRIPLER

SLVS273– FEBRUARY 2000

TYPICAL CHARACTERISTICS

**OUTPUT VOLTAGE
vs
INPUT VOLTAGE**

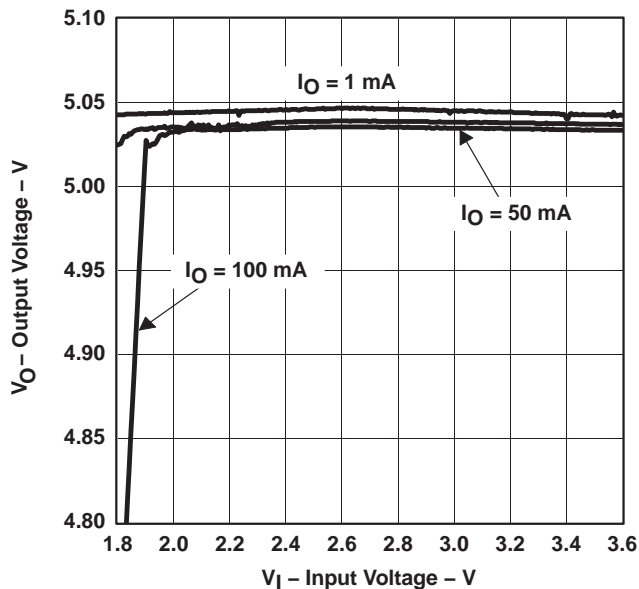

Figure 7

OUTPUT VOLTAGE RIPPLE

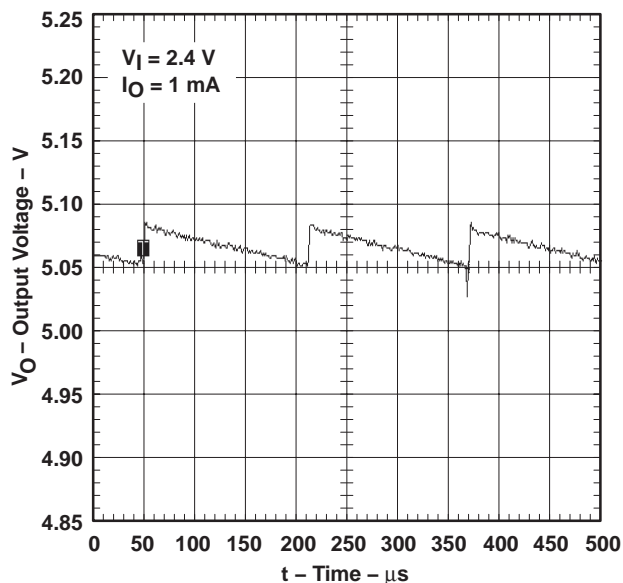

Figure 8

OUTPUT VOLTAGE RIPPLE

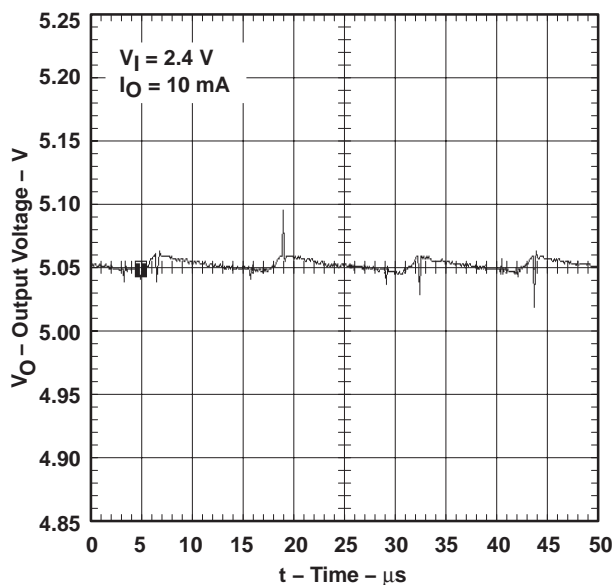

Figure 9

OUTPUT VOLTAGE RIPPLE

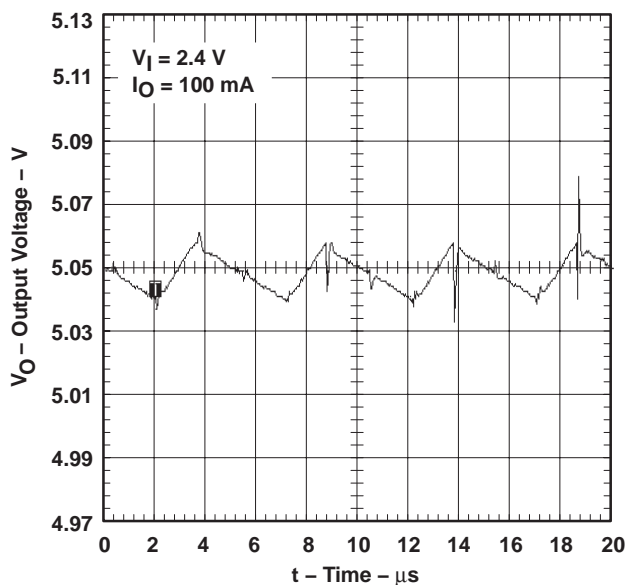

Figure 10



TYPICAL CHARACTERISTICS

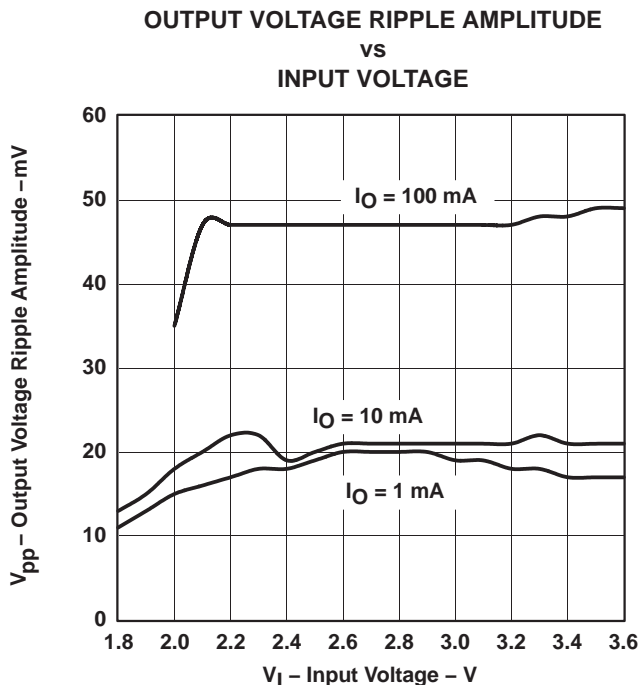

Figure 11

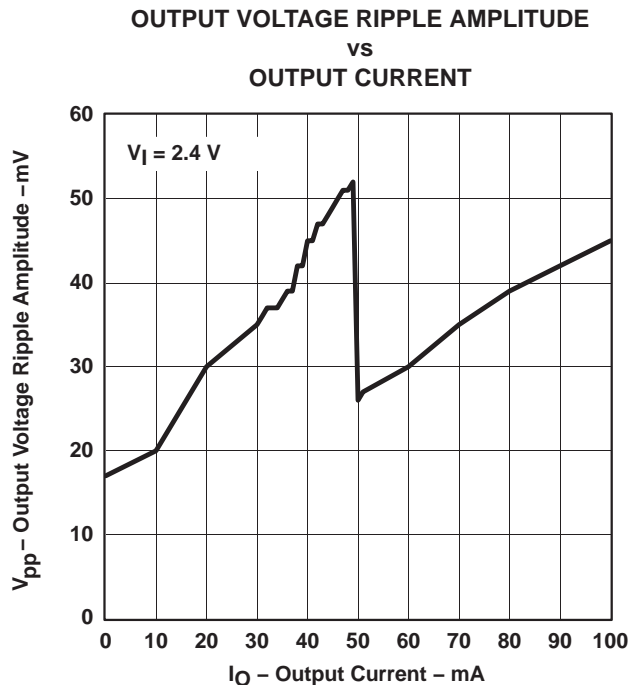

Figure 12

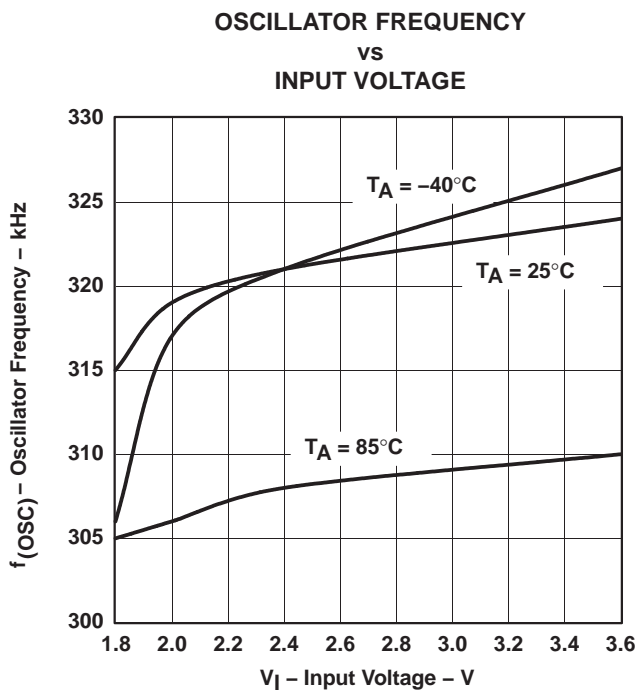

Figure 13

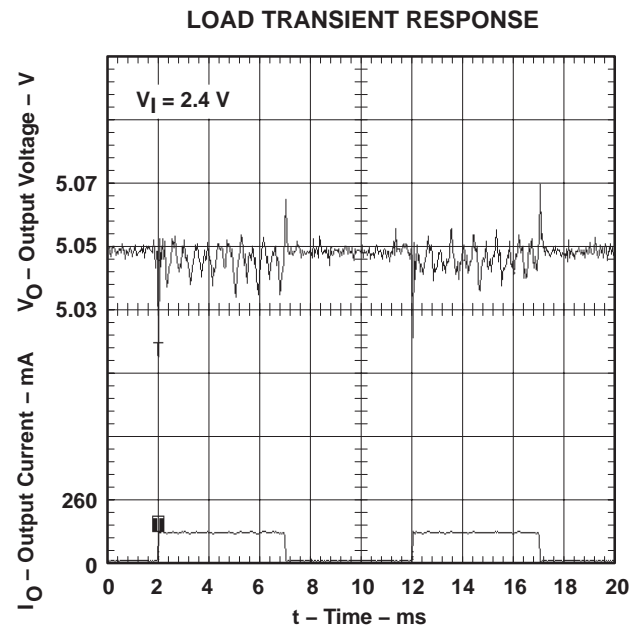

Figure 14

TYPICAL CHARACTERISTICS

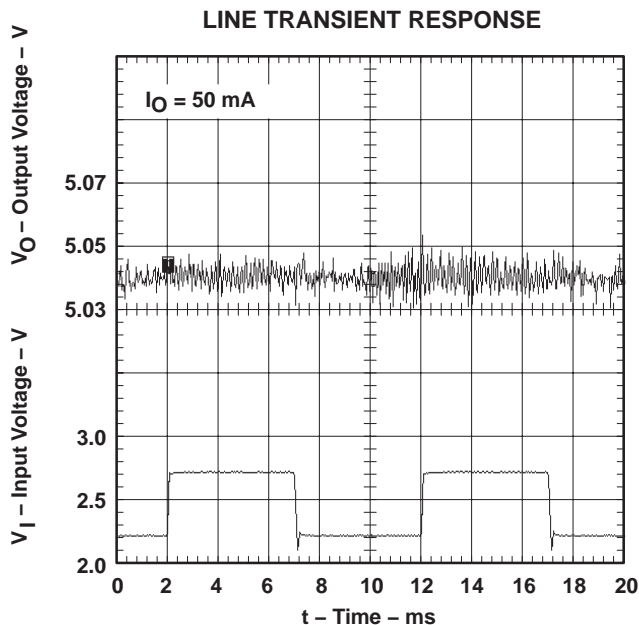

Figure 15

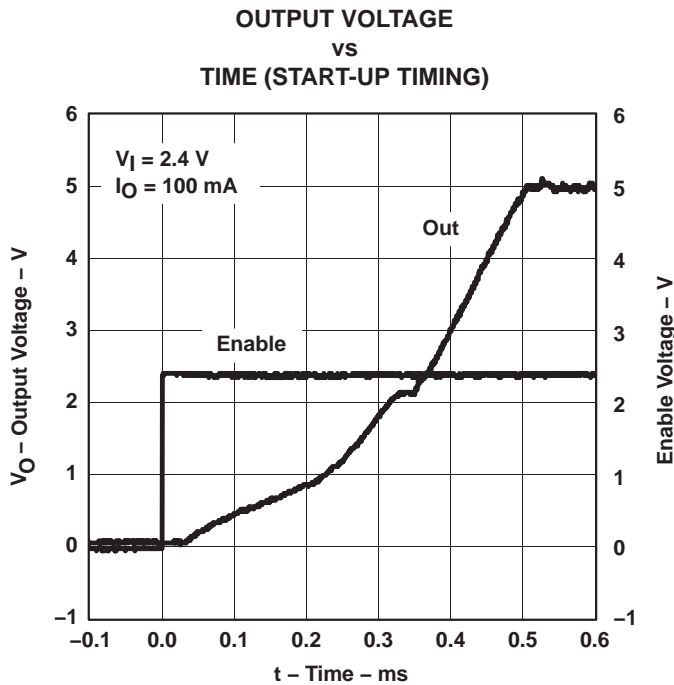

Figure 16

APPLICATION INFORMATION

capacitor selection

The TPS6014x requires only four external capacitors as shown in the basic application circuit. Their capacitance values are closely linked to the output current and output ripple requirements. For lowest ripple, low ESR (<0.1 Ω) capacitors should be used at the input and output of the charge pump.

The input capacitor improves system efficiency by reducing the input impedance. It also stabilizes the input current of the power source. The input capacitor should be chosen according to the power supply used and the distance from the power source to the converter IC. The input capacitor selection also depends on the output ripple requirements. C_i is recommended to be about two to four times as large as the flying capacitors. The lower the ESR of the input capacitor C_i, the lower is the output ripple.

The output capacitor C_o can be selected from 2-times to 50-times larger than the flying capacitor, depending on the ripple tolerance. The larger C_o and the lower its ESR, the lower will be the output voltage ripple.

Generally, the flying capacitors will be the smallest. Only ceramic capacitors are recommended because of their low ESR and because they retain their capacitance at the switching frequency. Please be aware that, depending on the material used to manufacture them, ceramic capacitors might lose their capacitance over temperature and voltage. Ceramic capacitors of type X7R or X5R material will keep their capacitance over temperature and voltage, whereas Z5U or Y5V-type capacitors will decrease in capacitance. Table 2 lists recommended capacitor values.

APPLICATION INFORMATION

capacitor selection (continued)

Table 2. Recommended Capacitor Values

I_O (mA)	C_i (μ F)	$C(xF)$ (μ F)	C_o (μ F)	V_{ppTYP} (mV)
0 – 50	4.7	2.2	4.7	40
0 – 100	4.7	2.2	10	40
0 – 100	4.7	2.2	22	18

If the measured output voltage ripple is too high for the application, improvements can be made. The first step is to increase the capacitance at the output. If the ripple is still too high, the second step would be to increase the capacitance at the input. For lower output currents, lower value flying capacitors can be used. Tables 3 and 4 lists the manufacturers of recommended capacitors.

Table 3. Recommended Capacitors

MANUFACTURER	PART NUMBER	CAPACITANCE	CASE SIZE	TYPE
Taiyo Yuden	LMK212BJ105KG–T	1 μ F	0805	Ceramic
	LMK212BJ225MG–T	2.2 μ F	0805	Ceramic
	LMK316BJ475KL–T	4.7 μ F	1206	Ceramic
	LMK325BJ106MN–T	10 μ F	1210	Ceramic
	LMK432226MM–T	22 μ F	1812	Ceramic
AVX	0805ZC105KAT2A	1 μ F	0805	Ceramic
	1206ZC225KAT2A	2.2 μ F	1206	Ceramic

NOTE: Case code compatibility with EIA 535BAAC and CECC30801 molded chips.

Table 4. Recommended Capacitor Manufacturers

MANUFACTURER	CAPACITOR TYPE	INTERNET SITE
Taiyo Yuden	X7R/X5R ceramic	http://www.t-yuden.com/
AVX	X7R/X5R ceramic	http://www.avxcorp.com/

APPLICATION INFORMATION

power dissipation

The power dissipated in the TPS6014x depends mainly on input voltage and output current and is described by the following:

$$P_{(DISS)} = I_O \times (3 \times V_I - V_O) \quad (5)$$

By observation of the above equation, it can be seen that the power dissipation is worse for the highest input voltage V_I and the highest output current I_O . For an input voltage of 3.6 V and an output current of 100 mA, the calculated power dissipation $P_{(DISS)}$ is 580 mW. This is also the point where the charge pump operates with its lowest efficiency, which is only 45%, and hence with the highest power losses.

$P_{(DISS)}$ must be less than that allowed by the package rating. The thermal resistance junction to ambient of the thermally enhanced TSSOP is 178°C/W for an unsoldered package. The thermal resistance junction to case, with the exposed thermal pad soldered to an infinitive heat sink, is 3.5°C/W.

With the recommended maximum junction temperature of 125°C and an assumed maximum ambient operating temperature of 85°C, the maximum allowed thermal resistance junction to ambient of the system can be calculated as follows:

$$R_{\Theta JA \max} = \frac{T_{J \max} - T_A}{P_{(DISS) \max}} = \frac{125^\circ\text{C} - 85^\circ\text{C}}{580 \text{ mW}} = 69^\circ\text{C/W} \quad (6)$$

Using a board layout as described in the application information section, $R_{\Theta JA}$ is typically 56°C/W for an unsoldered PowerPad and 41°C/W for a soldered PowerPad.

For more information, refer to the PowerPad application report (Literature Number: SLMA002).

APPLICATION INFORMATION

layout and board space

Careful board layout is necessary due to the high transient currents and switching frequency of the converter. All capacitors should be soldered in close proximity to the IC. Connect ground and power ground terminals through a short, low-impedance trace. A PCB layout proposal for a two-layer board is given in Figure 17. The bottom layer of the board carries only ground potential for best performance. The layout also provides improved thermal performance as the exposed lead frame of the PowerPad package is soldered to the PCB.

An evaluation module for the TPS60140 is available and can be ordered under product code TPS60140EVM–144. The EVM uses the layout shown in Figure 17.

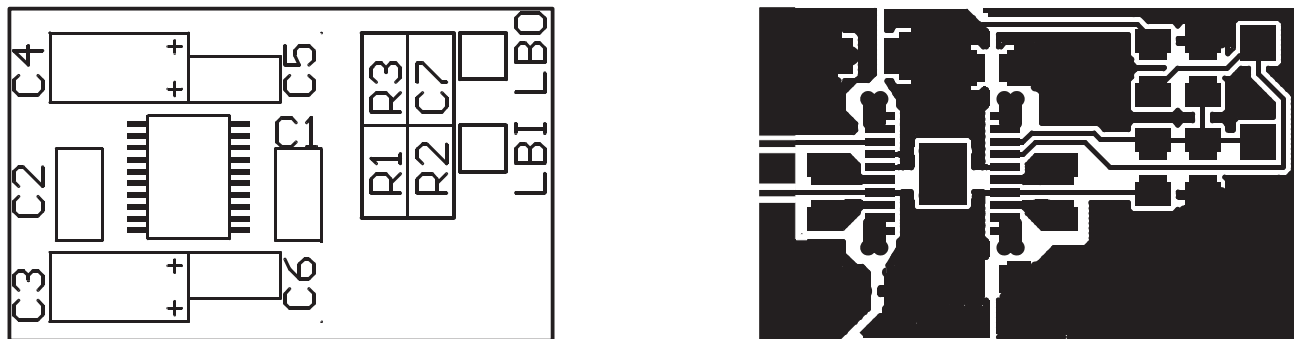

NOTE: Actual size is 15 mm x 25 mm.

Figure 17. Recommended Component Placement and Board Layout

Table 5. Component Identification

IC1	TPS6014x
C1, C2	Flying capacitors
C3, C6	Input capacitors
C4, C5	Output capacitors
C7	Stabilization capacitor for LBI
R1, R2	Resistive divider for LBI
R3	Pullup resistor for LBO

The best performance of the converter is achieved with additional bypass capacitors C5 and C6 at the input and output. Capacitor C7 should be included if the large line transients are expected. The capacitors are not required. They can be omitted in most applications.

TPS60140, TPS60141
LOW POWER DC-DC CONVERTER
REGULATED 5 V, 100-mA CHARGE PUMP VOLTAGE TRIPLER
SLVS273– FEBRUARY 2000

APPLICATION INFORMATION

related information

application reports

For more application information see:

- *PowerPAD Application Report*, Literature Number SLMA002
- *TPS6010x/TPS6011x Charge Pump Application Report*, Literature Number SLVA070

device family products

Other devices in this family are:

PART NUMBER	DESCRIPTION
TPS60100	Regulated 3.3-V, 200-mA low-noise charge pump dc-dc converter
TPS60101	Regulated 3.3-V, 100-mA low-noise charge pump dc-dc converter
TPS60110	Regulated 5-V, 300-mA low-noise charge pump dc-dc converter
TPS60111	Regulated 5-V, 150-mA low-noise charge pump dc-dc converter
TPS60120	Regulated 3.3-V, 200-mA high efficiency charge pump dc-dc converter with low-battery comparator
TPS60121	Regulated 3.3-V, 200-mA high efficiency charge pump dc-dc converter with power-good comparator
TPS60122	Regulated 3.3-V, 100-mA high efficiency charge pump dc-dc converter with low-battery comparator
TPS60123	Regulated 3.3-V, 100-mA high efficiency charge pump dc-dc converter with power-good comparator
TPS60130	Regulated 5-V, 300-mA high efficiency charge pump dc-dc converter with low-battery comparator
TPS60131	Regulated 5-V, 300-mA high efficiency charge pump dc-dc converter with power-good comparator
TPS60132	Regulated 5-V, 150-mA high efficiency charge pump dc-dc converter with low-battery comparator
TPS60133	Regulated 5-V, 150-mA high efficiency charge pump dc-dc converter with power-good comparator



PACKAGING INFORMATION

Orderable Device	Status ⁽¹⁾	Package Type	Package Drawing	Pins	Package Qty	Eco Plan ⁽²⁾	Lead/Ball Finish	MSL Peak Temp ⁽³⁾
TPS60140PWP	ACTIVE	HTSSOP	PWP	20	70	Green (RoHS & no Sb/Br)	CU NIPDAU	Level-2-260C-1 YEAR
TPS60140PWPG4	ACTIVE	HTSSOP	PWP	20	70	Green (RoHS & no Sb/Br)	CU NIPDAU	Level-2-260C-1 YEAR
TPS60140PWPR	ACTIVE	HTSSOP	PWP	20	2000	Green (RoHS & no Sb/Br)	CU NIPDAU	Level-2-260C-1 YEAR
TPS60140PWPRG4	ACTIVE	HTSSOP	PWP	20	2000	Green (RoHS & no Sb/Br)	CU NIPDAU	Level-2-260C-1 YEAR
TPS60141PWP	ACTIVE	HTSSOP	PWP	20	70	Green (RoHS & no Sb/Br)	CU NIPDAU	Level-2-260C-1 YEAR
TPS60141PWPG4	ACTIVE	HTSSOP	PWP	20	70	Green (RoHS & no Sb/Br)	CU NIPDAU	Level-2-260C-1 YEAR
TPS60141PWPR	ACTIVE	HTSSOP	PWP	20	2000	Green (RoHS & no Sb/Br)	CU NIPDAU	Level-2-260C-1 YEAR
TPS60141PWPRG4	ACTIVE	HTSSOP	PWP	20	2000	Green (RoHS & no Sb/Br)	CU NIPDAU	Level-2-260C-1 YEAR

⁽¹⁾ The marketing status values are defined as follows:

ACTIVE: Product device recommended for new designs.

LIFEBUY: TI has announced that the device will be discontinued, and a lifetime-buy period is in effect.

NRND: Not recommended for new designs. Device is in production to support existing customers, but TI does not recommend using this part in a new design.

PREVIEW: Device has been announced but is not in production. Samples may or may not be available.

OBSELETE: TI has discontinued the production of the device.

⁽²⁾ Eco Plan - The planned eco-friendly classification: Pb-Free (RoHS), Pb-Free (RoHS Exempt), or Green (RoHS & no Sb/Br) - please check <http://www.ti.com/productcontent> for the latest availability information and additional product content details.

TBD: The Pb-Free/Green conversion plan has not been defined.

Pb-Free (RoHS): TI's terms "Lead-Free" or "Pb-Free" mean semiconductor products that are compatible with the current RoHS requirements for all 6 substances, including the requirement that lead not exceed 0.1% by weight in homogeneous materials. Where designed to be soldered at high temperatures, TI Pb-Free products are suitable for use in specified lead-free processes.

Pb-Free (RoHS Exempt): This component has a RoHS exemption for either 1) lead-based flip-chip solder bumps used between the die and package, or 2) lead-based die adhesive used between the die and leadframe. The component is otherwise considered Pb-Free (RoHS compatible) as defined above.

Green (RoHS & no Sb/Br): TI defines "Green" to mean Pb-Free (RoHS compatible), and free of Bromine (Br) and Antimony (Sb) based flame retardants (Br or Sb do not exceed 0.1% by weight in homogeneous material)

⁽³⁾ MSL, Peak Temp. -- The Moisture Sensitivity Level rating according to the JEDEC industry standard classifications, and peak solder temperature.

Important Information and Disclaimer:The information provided on this page represents TI's knowledge and belief as of the date that it is provided. TI bases its knowledge and belief on information provided by third parties, and makes no representation or warranty as to the accuracy of such information. Efforts are underway to better integrate information from third parties. TI has taken and continues to take reasonable steps to provide representative and accurate information but may not have conducted destructive testing or chemical analysis on incoming materials and chemicals. TI and TI suppliers consider certain information to be proprietary, and thus CAS numbers and other limited information may not be available for release.

In no event shall TI's liability arising out of such information exceed the total purchase price of the TI part(s) at issue in this document sold by TI to Customer on an annual basis.

TAPE AND REEL INFORMATION



QUADRANT ASSIGNMENTS FOR PIN 1 ORIENTATION IN TAPE

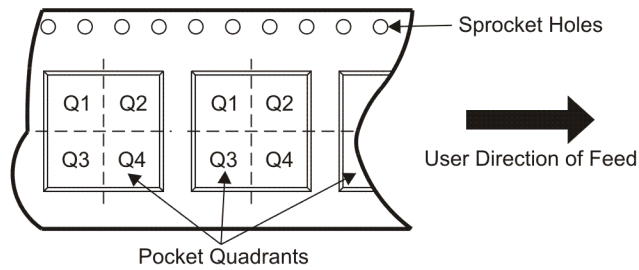

*All dimensions are nominal

Device	Package Type	Package Drawing	Pins	SPQ	Reel Diameter (mm)	Reel Width W1 (mm)	A0 (mm)	B0 (mm)	K0 (mm)	P1 (mm)	W (mm)	Pin1 Quadrant
TPS60140PWPR	HTSSOP	PWP	20	2000	330.0	16.4	6.95	7.1	1.6	8.0	16.0	Q1
TPS60141PWPR	HTSSOP	PWP	20	2000	330.0	16.4	6.95	7.1	1.6	8.0	16.0	Q1

TAPE AND REEL BOX DIMENSIONS



*All dimensions are nominal

Device	Package Type	Package Drawing	Pins	SPQ	Length (mm)	Width (mm)	Height (mm)
TPS60140PWPR	HTSSOP	PWP	20	2000	346.0	346.0	33.0
TPS60141PWPR	HTSSOP	PWP	20	2000	346.0	346.0	33.0

PWP (R-PDSO-G**)

PowerPAD™ PLASTIC SMALL-OUTLINE PACKAGE

20 PIN SHOWN

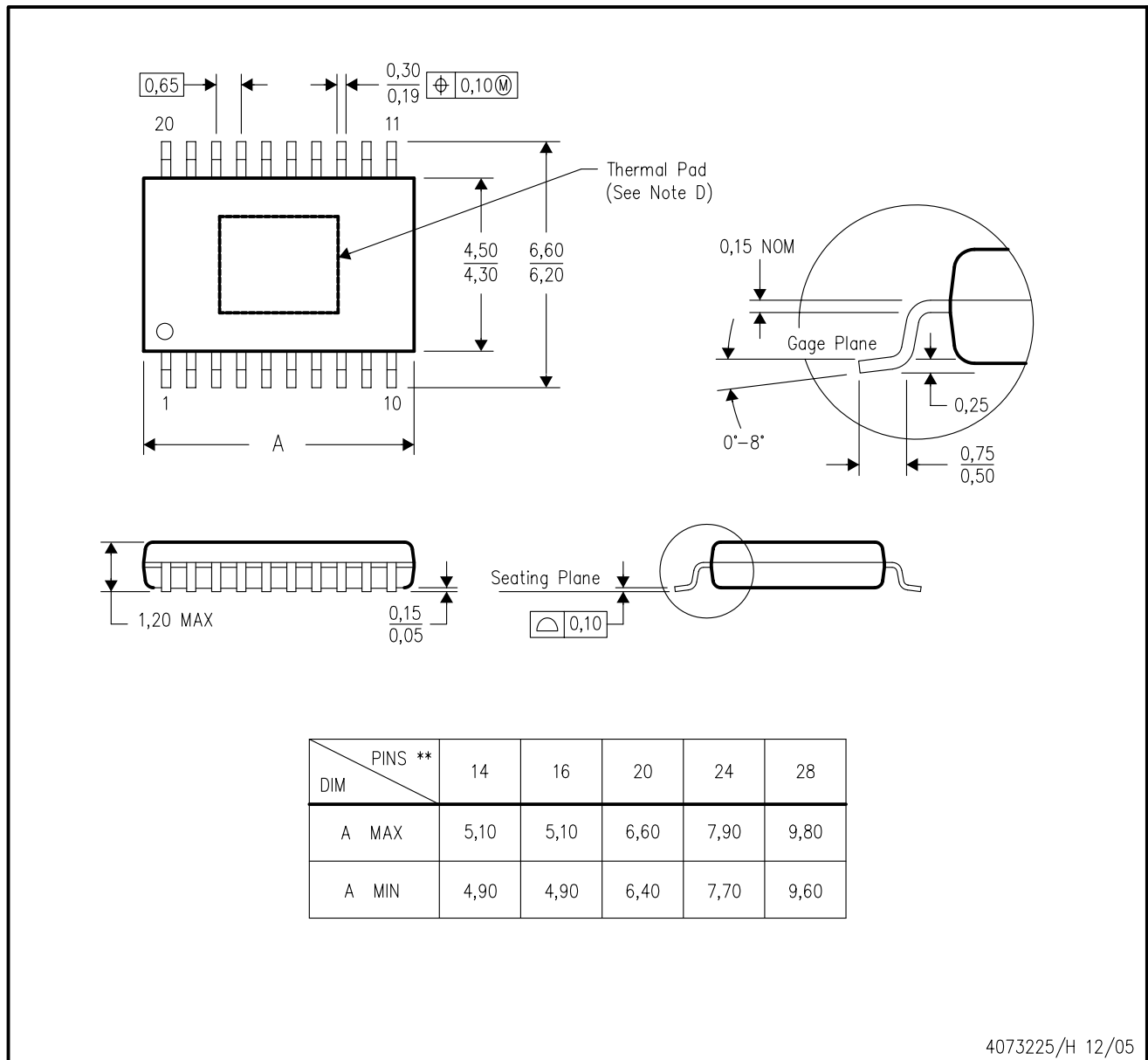

4073225/H 12/05

- NOTES:
- A. All linear dimensions are in millimeters.
 - B. This drawing is subject to change without notice.
 - C. Body dimensions do not include mold flash or protrusions. Mold flash and protrusion shall not exceed 0.15 per side.
 - D. This package is designed to be soldered to a thermal pad on the board. Refer to Technical Brief, PowerPad Thermally Enhanced Package, Texas Instruments Literature No. SLMA002 for information regarding recommended board layout. This document is available at www.ti.com <<http://www.ti.com>>.
 - E. Falls within JEDEC MO-153

PowerPAD is a trademark of Texas Instruments.

THERMAL INFORMATION

This PowerPAD™ package incorporates an exposed thermal pad that is designed to be attached directly to an external heatsink. The thermal pad must be soldered directly to the printed circuit board (PCB). After soldering, the PCB can be used as a heatsink. In addition, through the use of thermal vias, the thermal pad can be attached directly to the appropriate copper plane shown in the electrical schematic for the device, or alternatively, can be attached to a special heatsink structure designed into the PCB. This design optimizes the heat transfer from the integrated circuit (IC).

For additional information on the PowerPAD package and how to take advantage of its heat dissipating abilities, refer to Technical Brief, PowerPAD Thermally Enhanced Package, Texas Instruments Literature No. SLMA002 and Application Brief, PowerPAD Made Easy, Texas Instruments Literature No. SLMA004. Both documents are available at www.ti.com.

The exposed thermal pad dimensions for this package are shown in the following illustration.

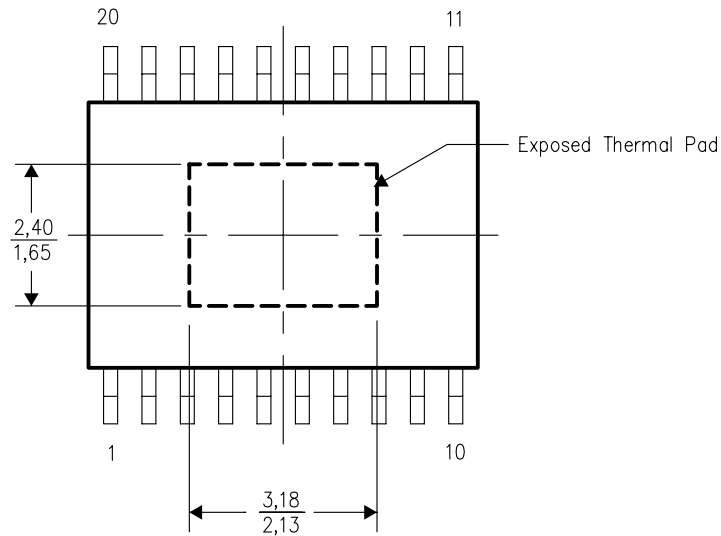

Top View

NOTE: All linear dimensions are in millimeters

Exposed Thermal Pad Dimensions

PWP (R-PDSO-G20) PowerPAD™

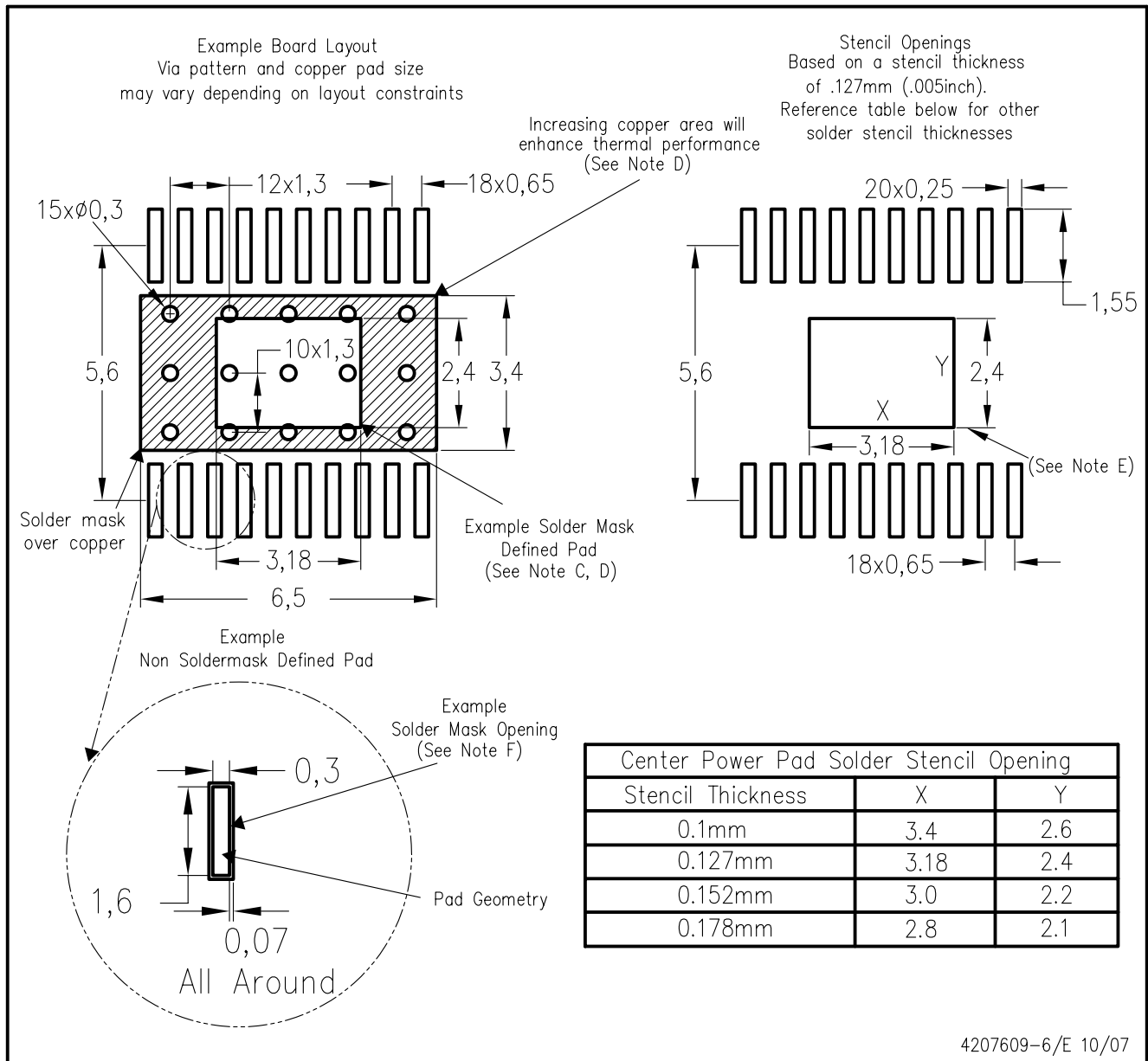

- NOTES:
- A. All linear dimensions are in millimeters.
 - B. This drawing is subject to change without notice.
 - C. Customers should place a note on the circuit board fabrication drawing not to alter the center solder mask defined pad.
 - D. This package is designed to be soldered to a thermal pad on the board. Refer to Technical Brief, PowerPad Thermally Enhanced Package, Texas Instruments Literature No. SLMA002, SLMA004, and also the Product Data Sheets for specific thermal information, via requirements, and recommended board layout. These documents are available at www.ti.com <<http://www.ti.com>>. Publication IPC-7351 is recommended for alternate designs.
 - E. Laser cutting apertures with trapezoidal walls and also rounding corners will offer better paste release. Customers should contact their board assembly site for stencil design recommendations. Example stencil design based on a 50% volumetric metal load solder paste. Refer to IPC-7525 for other stencil recommendations.
 - F. Customers should contact their board fabrication site for solder mask tolerances between and around signal pads.

PowerPAD is a trademark of Texas Instruments.

IMPORTANT NOTICE

Texas Instruments Incorporated and its subsidiaries (TI) reserve the right to make corrections, modifications, enhancements, improvements, and other changes to its products and services at any time and to discontinue any product or service without notice. Customers should obtain the latest relevant information before placing orders and should verify that such information is current and complete. All products are sold subject to TI's terms and conditions of sale supplied at the time of order acknowledgment.

TI warrants performance of its hardware products to the specifications applicable at the time of sale in accordance with TI's standard warranty. Testing and other quality control techniques are used to the extent TI deems necessary to support this warranty. Except where mandated by government requirements, testing of all parameters of each product is not necessarily performed.

TI assumes no liability for applications assistance or customer product design. Customers are responsible for their products and applications using TI components. To minimize the risks associated with customer products and applications, customers should provide adequate design and operating safeguards.

TI does not warrant or represent that any license, either express or implied, is granted under any TI patent right, copyright, mask work right, or other TI intellectual property right relating to any combination, machine, or process in which TI products or services are used. Information published by TI regarding third-party products or services does not constitute a license from TI to use such products or services or a warranty or endorsement thereof. Use of such information may require a license from a third party under the patents or other intellectual property of the third party, or a license from TI under the patents or other intellectual property of TI.

Reproduction of TI information in TI data books or data sheets is permissible only if reproduction is without alteration and is accompanied by all associated warranties, conditions, limitations, and notices. Reproduction of this information with alteration is an unfair and deceptive business practice. TI is not responsible or liable for such altered documentation. Information of third parties may be subject to additional restrictions.

Resale of TI products or services with statements different from or beyond the parameters stated by TI for that product or service voids all express and any implied warranties for the associated TI product or service and is an unfair and deceptive business practice. TI is not responsible or liable for any such statements.

TI products are not authorized for use in safety-critical applications (such as life support) where a failure of the TI product would reasonably be expected to cause severe personal injury or death, unless officers of the parties have executed an agreement specifically governing such use. Buyers represent that they have all necessary expertise in the safety and regulatory ramifications of their applications, and acknowledge and agree that they are solely responsible for all legal, regulatory and safety-related requirements concerning their products and any use of TI products in such safety-critical applications, notwithstanding any applications-related information or support that may be provided by TI. Further, Buyers must fully indemnify TI and its representatives against any damages arising out of the use of TI products in such safety-critical applications.

TI products are neither designed nor intended for use in military/aerospace applications or environments unless the TI products are specifically designated by TI as military-grade or "enhanced plastic." Only products designated by TI as military-grade meet military specifications. Buyers acknowledge and agree that any such use of TI products which TI has not designated as military-grade is solely at the Buyer's risk, and that they are solely responsible for compliance with all legal and regulatory requirements in connection with such use.

TI products are neither designed nor intended for use in automotive applications or environments unless the specific TI products are designated by TI as compliant with ISO/TS 16949 requirements. Buyers acknowledge and agree that, if they use any non-designated products in automotive applications, TI will not be responsible for any failure to meet such requirements.

Following are URLs where you can obtain information on other Texas Instruments products and application solutions:

Products

Amplifiers	amplifier.ti.com
Data Converters	dataconverter.ti.com
DSP	dsp.ti.com
Clocks and Timers	www.ti.com/clocks
Interface	interface.ti.com
Logic	logic.ti.com
Power Mgmt	power.ti.com
Microcontrollers	microcontroller.ti.com
RFID	www.ti-rfid.com
RF/IF and ZigBee® Solutions	www.ti.com/lprf

Applications

Audio	www.ti.com/audio
Automotive	www.ti.com/automotive
Broadband	www.ti.com/broadband
Digital Control	www.ti.com/digitalcontrol
Medical	www.ti.com/medical
Military	www.ti.com/military
Optical Networking	www.ti.com/opticalnetwork
Security	www.ti.com/security
Telephony	www.ti.com/telephony
Video & Imaging	www.ti.com/video
Wireless	www.ti.com/wireless

Mailing Address: Texas Instruments, Post Office Box 655303, Dallas, Texas 75265
Copyright © 2008, Texas Instruments Incorporated