

## HIGH-EFFICIENCY, 1-CELL AND 2-CELL BOOST CONVERTERS

### FEATURES

- Integrated Synchronous Rectifier for Highest Power Conversion Efficiency (>95%)
- Start-Up Into Full Load With Supply Voltages as Low as 0.9 V, Operating Down to 0.8 V
- 200-mA Output Current From 0.9-V Supply
- Powersave-Mode for Improved Efficiency at Low Output Currents
- Autodischarge Allows to Discharge Output Capacitor During Shutdown
- Device Quiescent Current Less Than 50  $\mu$ A
- Ease-of-Use Through Isolation of Load From Battery During Shutdown of Converter
- Integrated Antiringing Switch Across Inductor
- Integrated Low Battery Comparator
- Micro-Small 10-Pin MSOP or 3 mm x 3 mm QFN Package
- EVM Available (TPS6101xEVM-157)

### APPLICATIONS

- All Single- or Dual-Cell Battery Operated Products Like Internet Audio Players, Pager, Portable Medical Diagnostic Equipment, Remote Control, Wireless Headsets

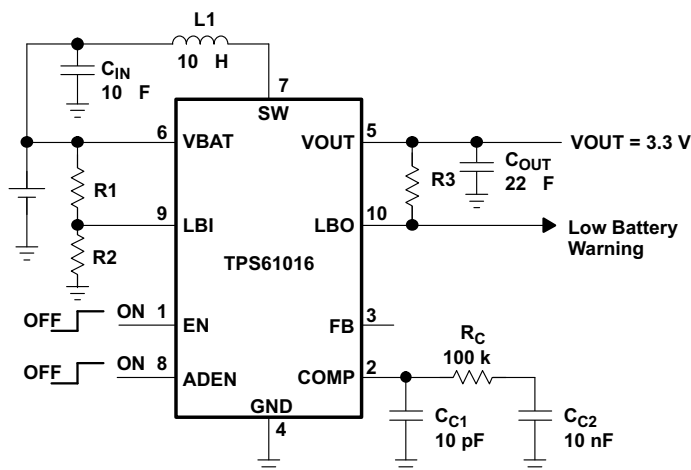
### DESCRIPTION

The TPS6101x devices are boost converters intended for systems that are typically operated from a single- or dual-cell nickel-cadmium (NiCd), nickel-metal hydride (NiMH), or alkaline battery.

The converter output voltage can be adjusted from 1.5 V to a maximum of 3.3 V, by an external resistor divider or, is fixed internally on the chip. The devices provide an output current of 200 mA with a supply voltage of only 0.9 V. The converter starts up into a full load with a supply voltage of only 0.9 V and stays in operation with supply voltages down to 0.8 V.

The converter is based on a fixed frequency, current mode, pulse-width-modulation (PWM) controller that goes automatically into power save mode at light load. It uses a built-in synchronous rectifier, so, no external Schottky diode is required and the system efficiency is improved. The current through the switch is limited to a maximum value of 1300 mA. The converter can be disabled to minimize battery drain. During shutdown, the load is completely isolated from the battery.

An autodischarge function allows discharging the output capacitor during shutdown mode. This is especially useful when a microcontroller or memory is supplied, where residual voltage across the output capacitor can cause malfunction of the applications. When programming the ADEN-pin, the autodischarge function can be disabled. A low-EMI mode is implemented to reduce interference and radiated electromagnetic energy when the converter enters the discontinuous conduction mode. The device is packaged in the micro-small space saving 10-pin MSOP package. The TPS61010 is also available in a 3 mm x 3 mm 10-pin QFN package.



Please be aware that an important notice concerning availability, standard warranty, and use in critical applications of Texas Instruments semiconductor products and disclaimers thereto appears at the end of this data sheet.



These devices have limited built-in ESD protection. The leads should be shorted together or the device placed in conductive foam during storage or handling to prevent electrostatic damage to the MOS gates.

### AVAILABLE OUTPUT VOLTAGE OPTIONS

T <sub>A</sub>	OUTPUT VOLTAGE	PART NUMBER <sup>(1)</sup>	MARKING DGS PACKAGE	PACKAGE <sup>(2)</sup>
-40°C to 85°C	Adjustable from 1.5 V to 3.3 V	TPS61010DGS	AIP	10-Pin MSOP
	1.5 V	TPS61011DGS	AIQ	
	1.8 V	TPS61012DGS	AIR	
	2.5 V	TPS61013DGS	AIS	
	2.8 V	TPS61014DGS	AIT	
	3.0 V	TPS61015DGS	AIU	
	3.3 V	TPS61016DGS	AIV	
	Adjustable from 1.5 V to 3.3 V	TPS61010DRC	AYA	10-Pin QFN

- (1) The DGS package and the DRC package are available taped and reeled. Add a R suffix to device type (e.g. TPS61010DGSR or TPS61010DRCR) to order quantities of 3000 devices per reel. The DRC package is also available in mini-reels. Add a T suffix to the device type (e.g. TPS61010DRCT) to order quantities of 250 devices per reel.
- (2) For the most current package and ordering information, see the Package Option Addendum at the end of this document, or see the TI Web site at [www.ti.com](http://www.ti.com).

### ABSOLUTE MAXIMUM RATINGS

over operating free-air temperature range (unless otherwise noted)<sup>(1)</sup>

		UNIT
Input voltage range:	VBAT, VOUT, EN, LBI, FB, ADEN	-0.3 V to 3.6 V
	SW	-0.3 V to 7 V
Voltage range:	LBO, COMP	-0.3 V to 3.6 V
Operating free-air temperature range, T <sub>A</sub>		-40°C to 85°C
Maximum junction temperature, T <sub>J</sub>		150°C
Storage temperature range, T <sub>stg</sub>		-65°C to 150°C
Lead temperature 1,6 mm (1/16 inch) from case for 10s		260°C

- (1) Stresses beyond those listed under "absolute maximum ratings" may cause permanent damage to the device. These are stress ratings only, and functional operation of the device at these or any other conditions beyond those indicated under "recommended operating conditions" is not implied. Exposure to absolute-maximum-rated conditions for extended periods may affect device reliability.

### DISSIPATION RATING TABLE

PACKAGE	T <sub>A</sub> < 25°C POWER RATING	DERATING FACTOR ABOVE T <sub>A</sub> = 25°C	T <sub>A</sub> = 70°C POWER RATING	T <sub>A</sub> = 85°C POWER RATING
DGS	424 mW	3.4 mW/°C	271 mW	220 mW

### RECOMMENDED OPERATING CONDITIONS

	MIN	NOM	MAX	UNIT
Supply voltage at VBAT, V <sub>I</sub>	0.8		VOUT	V
Maximum output current at VIN = 1.2 V, I <sub>O</sub>	100			mA
Maximum output current at VIN = 2.4 V, I <sub>O</sub>	200			mA
Inductor, L1	10	33		μH
Input capacitor, C <sub>I</sub>		10		μF
Output capacitor, C <sub>O</sub>	10	22	47	μF
Operating virtual junction temperature, T <sub>J</sub>	-40		125	°C

## ELECTRICAL CHARACTERISTICS

over recommended operating free-air temperature range,  $V_{BAT} = 1.2\text{ V}$ ,  $EN = V_{BAT}$  (unless otherwise noted)

PARAMETER		TEST CONDITIONS	MIN	TYP	MAX	UNIT
$V_I$	Minimum input voltage for start-up	$R_L = 33\ \Omega$		0.85	0.9	V
		$R_L = 3\ \text{k}\Omega$ , $T_A = 25\ ^\circ\text{C}$		0.8		
	Input voltage once started	$I_O = 100\ \text{mA}$		0.8		
$V_O$	Programmable output voltage range	TPS61010, $I_{OUT} = 100\ \text{mA}$		1.5	3.3	V
	Output voltage	TPS61011, $0.8\ \text{V} < V_I < V_O$ , $I_O = 0$ to $100\ \text{mA}$	1.45	1.5	1.55	V
		TPS61012, $0.8\ \text{V} < V_I < V_O$ , $I_O = 0$ to $100\ \text{mA}$	1.74	1.8	1.86	V
		TPS61013, $0.8\ \text{V} < V_I < V_O$ , $I_O = 0$ to $100\ \text{mA}$	2.42	2.5	2.58	V
		TPS61013, $1.6\ \text{V} < V_I < V_O$ , $I_O = 0$ to $200\ \text{mA}$	2.42	2.5	2.58	V
		TPS61014, $0.8\ \text{V} < V_I < V_O$ , $I_O = 0$ to $100\ \text{mA}$	2.72	2.8	2.88	V
		TPS61014, $1.6\ \text{V} < V_I < V_O$ , $I_O = 0$ to $200\ \text{mA}$	2.72	2.8	2.88	V
		TPS61015, $0.8\ \text{V} < V_I < V_O$ , $I_O = 0$ to $100\ \text{mA}$	2.9	3.0	3.1	V
		TPS61015, $1.6\ \text{V} < V_I < V_O$ , $I_O = 0$ to $200\ \text{mA}$	2.9	3.0	3.1	V
TPS61016, $0.8\ \text{V} < V_I < V_O$ , $I_O = 0$ to $100\ \text{mA}$	3.2	3.3	3.4	V		
TPS61016, $1.6\ \text{V} < V_I < V_O$ , $I_O = 0$ to $200\ \text{mA}$	3.2	3.3	3.4	V		
$I_O$	Maximum continuous output current	$V_I > 0.8\ \text{V}$		100		mA
		$V_I > 1.8\ \text{V}$		250		
$I_{(SW)}$	Switch current limit	TPS61011, once started	0.39	0.48		A
		TPS61012, once started	0.54	0.56		
		TPS61013, once started	0.85	0.93		
		TPS61014, once started	0.95	1.01		
		TPS61015, once started	1	1.06		
		TPS61016, once started	1.07	1.13		
$V_{(FB)}$	Feedback voltage		480	500	520	mV
f	Oscillator frequency		420	500	780	kHz
D	Maximum duty cycle			85%		
$r_{DS(on)}$	NMOS switch on-resistance	$V_O = 1.5\ \text{V}$		0.37	0.51	$\Omega$
	PMOS switch on-resistance			0.45	0.54	
$r_{DS(on)}$	NMOS switch on-resistance	$V_O = 3.3\ \text{V}$		0.2	0.37	$\Omega$
	PMOS switch on-resistance			0.3	0.45	
	Line regulation <sup>(1)</sup>	$V_I = 1.2\ \text{V}$ to $1.4\ \text{V}$ , $I_O = 100\ \text{mA}$		0.3		%V
	Load regulation <sup>(1)</sup>	$V_I = 1.2\ \text{V}$ ; $I_O = 50\ \text{mA}$ to $100\ \text{mA}$		0.1		
	Autodischarge switch resistance			300	400	$\Omega$
	Residual output voltage after autodischarge	ADEN = $V_{BAT}$ ; EN = GND			0.4	V
$V_{IL}$	LBI voltage threshold <sup>(2)</sup>	$V_{(LBI)}$ voltage decreasing	480	500	520	mV
	LBI input hysteresis			10		mv
	LBI input current			0.01	0.03	
$V_{OL}$	LBO output low voltage	$V_{(LBI)} = 0\ \text{V}$ , $V_O = 3.3\ \text{V}$ , $I_{(OL)} = 10\ \mu\text{A}$		0.04	0.2	V
	LBO output leakage current	$V_{(LBI)} = 650\ \text{mV}$ , $V_{(LBO)} = V_O$			0.03	$\mu\text{A}$
$I_{(FB)}$	FB input bias current (TPS61010 only)	$V_{(FB)} = 500\ \text{mV}$		0.01	0.03	
$V_{IL}$	EN and ADEN input low voltage	$0.8\ \text{V} < V_{BAT} < 3.3\ \text{V}$			$0.2 \times V_{BAT}$	V

(1) Line and load regulation is measured as a percentage deviation from the nominal value (i.e., as percentage deviation from the nominal output voltage). For line regulation, x %/V stands for  $\pm x\%$  change of the nominal output voltage per 1-V change on the input/supply voltage. For load regulation, y% stands for  $\pm y\%$  change of the nominal output voltage per the specified current change.

(2) For proper operation the voltage at LBI may not exceed the voltage at  $V_{BAT}$ .

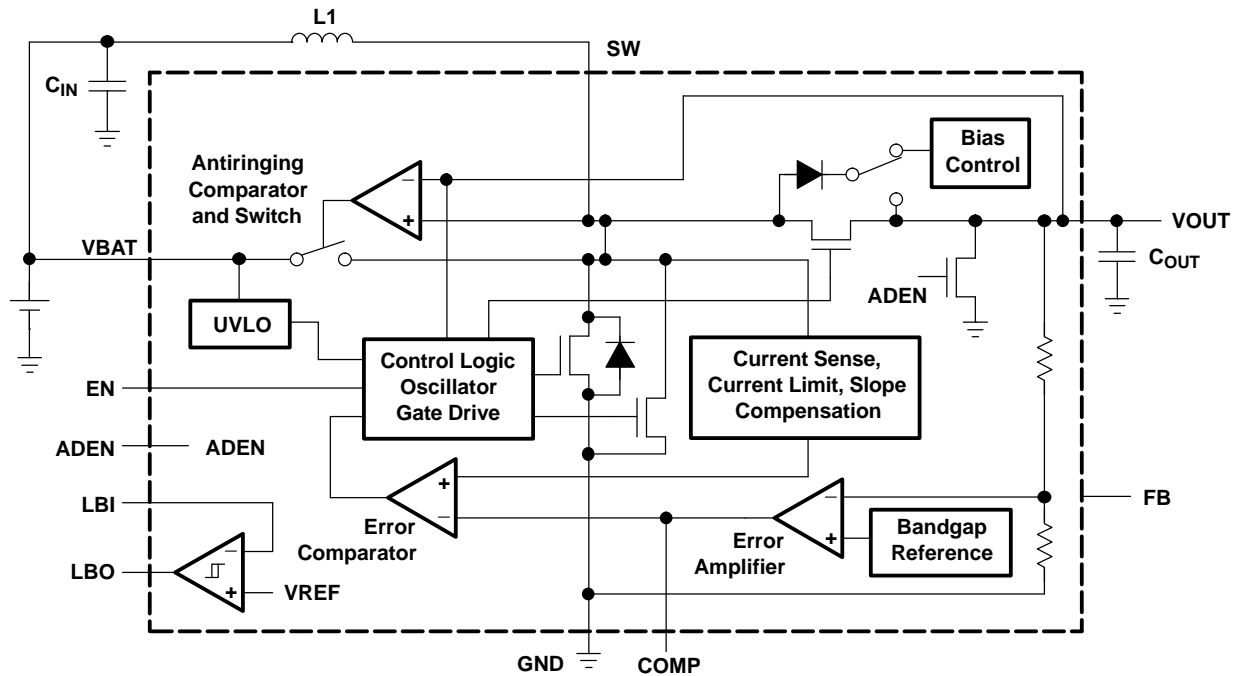
**ELECTRICAL CHARACTERISTICS (continued)**

over recommended operating free-air temperature range, V<sub>BAT</sub> = 1.2 V, EN = V<sub>BAT</sub> (unless otherwise noted)

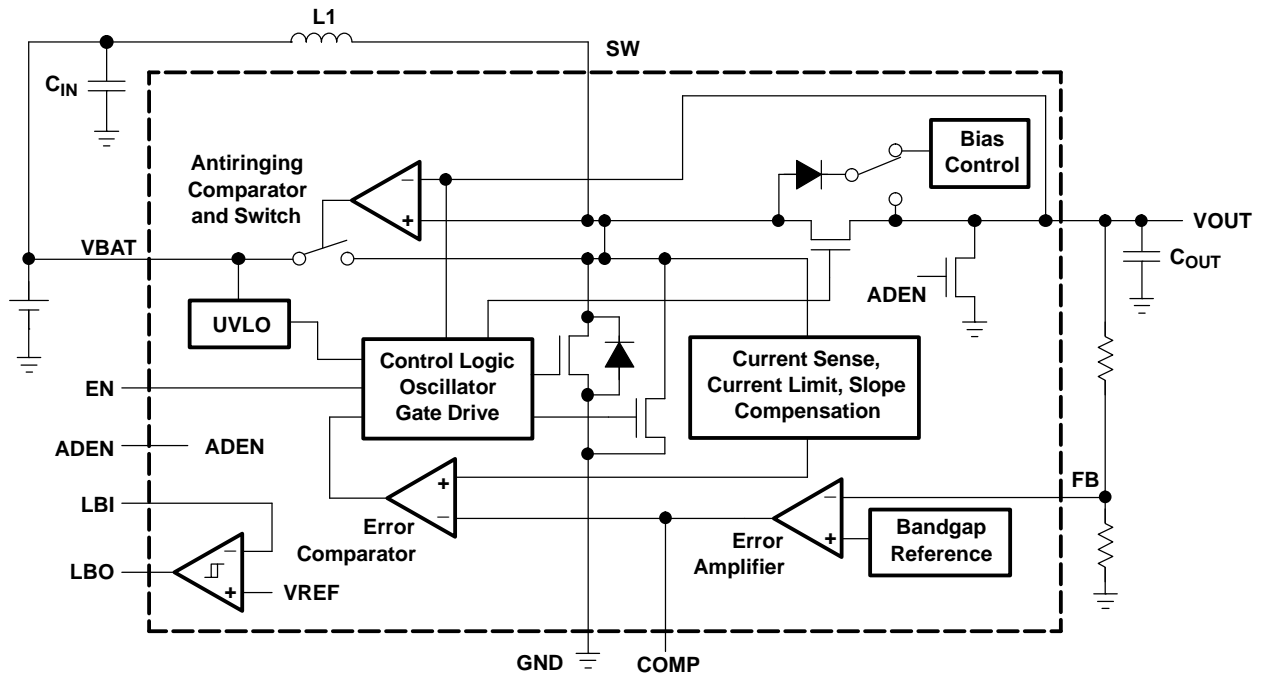
PARAMETER	TEST CONDITIONS	MIN	TYP	MAX	UNIT	
V <sub>IH</sub>	EN and ADEN input high voltage	0.8 V < V <sub>BAT</sub> < 3.3 V			V	
	EN and ADEN input current	EN and ADEN = GND or V <sub>BAT</sub>			μA	
I <sub>q</sub>	Quiescent current into pins V <sub>BAT</sub> /SW and V <sub>OUT</sub>	I <sub>L</sub> = 0 mA, V <sub>EN</sub> = V <sub>I</sub>	V <sub>BAT</sub> /SW	31	46	μA
			V <sub>O</sub>	5	8	μA
I <sub>off</sub>	Shutdown current from power source	V <sub>EN</sub> = 0 V, ADEN = V <sub>BAT</sub> , T <sub>A</sub> = 25°C			μA	

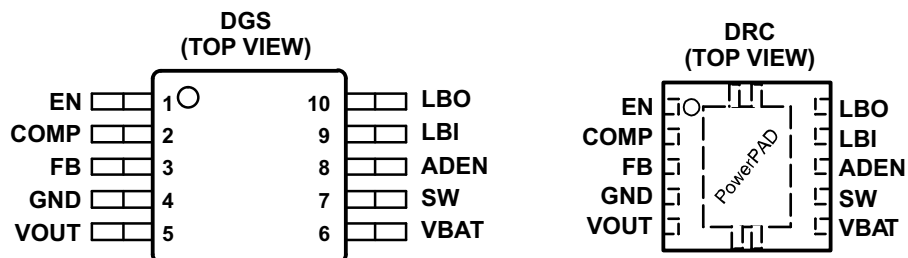
**FUNCTIONAL BLOCK DIAGRAMS**

fixed output voltage versions TPS61011 to TPS61016



**FUNCTIONAL BLOCK DIAGRAMS (continued)**  
**adjustable output voltage version TPS61010**





### Terminal Functions

Terminal			I/O	Description
Name	DRG No.	DRC No.		
ADEN	8	8	I	Autodischarge input. The autodischarge function is enabled if this pin is connected to VBAT, it is disabled if ADEN is tied to GND.
COMP	2	2	I	Compensation of error amplifier. Connect an R/C/C network to set frequency response of control loop.
EN	1	1	I	Chip-enable input. The converter is switched on if this pin is set high, it is switched off if this pin is connected to GND.
FB	3	3	I	Feedback input for adjustable output voltage version TPS61010. Output voltage is programmed depending on the output voltage divider connected there. For the fixed output voltage versions, leave FB-pin unconnected.
GND	4	4		Ground
LBI	9	9	I	Low-battery detector input. A low battery warning is generated at LBO when the voltage on LBI drops below the threshold of 500 mV. Connect LBI to GND or VBAT if the low-battery detector function is not used. Do not leave this pin floating.
LBO	10	10	O	Open-drain low-battery detector output. This pin is pulled low if the voltage on LBI drops below the threshold of 500 mV. A pullup resistor must be connected between LBO and VOUT.
SW	7	7	I	Switch input pin. The inductor is connected to this pin.
VOUT	5	5	O	Output voltage. Internal resistor divider sets regulated output voltage in fixed output voltage versions.
VBAT	6	6	I	Supply pin

### DETAILED DESCRIPTION

#### Controller Circuit

The device is based on a current-mode control topology using a constant frequency pulse-width modulator to regulate the output voltage. The controller limits the current through the power switch on a pulse by pulse basis. The current-sensing circuit is integrated in the device, therefore, no additional components are required. Due to the nature of the boost converter topology used here, the peak switch current is the same as the peak inductor current, which will be limited by the integrated current limiting circuits under normal operating conditions.

The control loop must be externally compensated with an R-C-C network connected to the COMP-pin.

#### Synchronous Rectifier

The device integrates an N-channel and a P-channel MOSFET transistor to realize a synchronous rectifier. There is no additional Schottky diode required. Because the device uses a integrated low  $r_{DS(on)}$  PMOS switch for rectification, the power conversion efficiency reaches 95%.

A special circuit is applied to disconnect the load from the input during shutdown of the converter. In conventional synchronous rectifier circuits, the backgate diode of the high-side PMOS is forward biased in shutdown and allows current flowing from the battery to the output. This device, however, uses a special circuit to disconnect the backgate diode of the high-side PMOS and so, disconnects the output circuitry from the source when the regulator is not enabled (EN = low).

The benefit of this feature for the system design engineer, is that the battery is not depleted during shutdown of the converter. So, no additional effort has to be made by the system designer to ensure disconnection of the battery from the output of the converter. Therefore, design performance will be increased without additional costs and board space.

## DETAILED DESCRIPTION (continued)

### Power-Save Mode

The TPS61010 is designed for high efficiency over a wide output current range. Even at light loads, the efficiency stays high because the switching losses of the converter are minimized by effectively reducing the switching frequency. The controller enters a powersave-mode if certain conditions are met. In this mode, the controller only switches on the transistor if the output voltage trips below a set threshold voltage. It ramps up the output voltage with one or several pulses, and goes again into powersave-mode once the output voltage exceeds a set threshold voltage.

### Device Enable

The device is shut down when EN is set to GND. In this mode, the regulator stops switching, all internal control circuitry including the low-battery comparator, is switched off, and the load is disconnected from the input (as described above in the synchronous rectifier section). This also means that the output voltage may drop below the input voltage during shutdown.

The device is put into operation when EN is set high. During start-up of the converter, the duty cycle is limited in order to avoid high peak currents drawn from the battery. The limit is set internally by the current limit circuit and is proportional to the voltage on the COMP-pin.

### Under-Voltage Lockout

An under-voltage lockout function prevents the device from starting up if the supply voltage on VBAT is lower than approximately 0.7 V. This under-voltage lockout function is implemented in order to prevent the malfunctioning of the converter. When in operation and the battery is being discharged, the device will automatically enter the shutdown mode if the voltage on VBAT drops below approximately 0.7 V.

### Autodischarge

The autodischarge function is useful for applications where the supply voltage of a  $\mu\text{C}$ ,  $\mu\text{P}$ , or memory has to be removed during shutdown in order to ensure a defined state of the system.

The autodischarge function is enabled when the ADEN is set high, and is disabled when the ADEN is set to GND. When the autodischarge function is enabled, the output capacitor will be discharged after the device is shut down by setting EN to GND. The capacitors connected to the output are discharged by an integrated switch of 300  $\Omega$ , hence the discharge time depends on the total output capacitance. The residual voltage on VOUT is less than 0.4 V after autodischarge.

### Low-Battery Detector Circuit (LBI and LBO)

The low-battery detector circuit is typically used to supervise the battery voltage and to generate an error flag when the battery voltage drops below a user-set threshold voltage. The function is active only when the device is enabled. When the device is disabled, the LBO-pin is high impedance. The LBO-pin goes active low when the voltage on the LBI-pin decreases below the set threshold voltage of 500 mV  $\pm$ 15 mV, which is equal to the internal reference voltage. The battery voltage, at which the detection circuit switches, can be programmed with a resistive divider connected to the LBI-pin. The resistive divider scales down the battery voltage to a voltage level of 500 mV, which is then compared to the LBI threshold voltage. The LBI-pin has a built-in hysteresis of 10 mV. See the application section for more details about the programming of the LBI-threshold.

If the low-battery detection circuit is not used, the LBI-pin should be connected to GND (or to VBAT) and the LBO-pin can be left unconnected. Do not let the LBI-pin float.

### Antiringing Switch

The device integrates a circuit that removes the ringing that typically appears on the SW-node when the converter enters the discontinuous current mode. In this case, the current through the inductor ramps to zero and the integrated PMOS switch turns off to prevent a reverse current from the output capacitors back to the battery. Due to remaining energy that is stored in parasitic components of the semiconductors and the inductor, a ringing on the SW pin is induced. The integrated antiringing switch clamps this voltage internally to  $V_{\text{BAT}}$  and therefore, dampens this ringing.

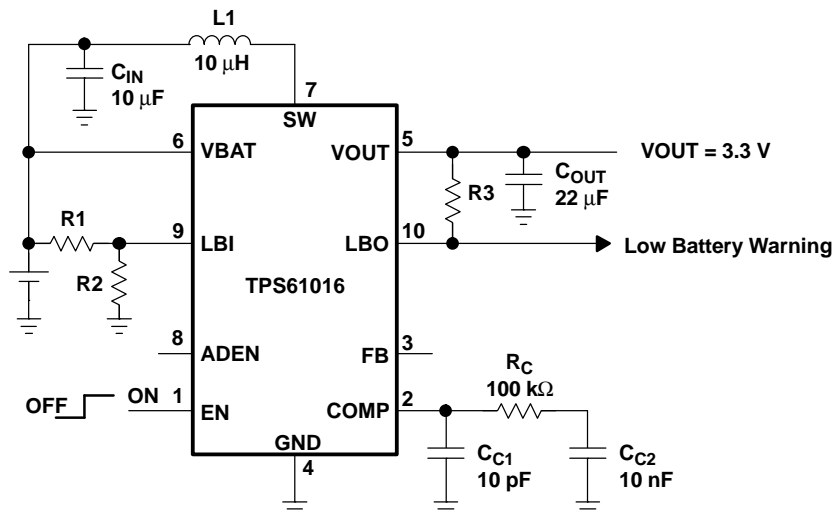
## DETAILED DESCRIPTION (continued)

### Adjustable Output Voltage

The devices with fixed output voltages are trimmed to operate with an output voltage accuracy of  $\pm 3\%$ .

The accuracy of the adjustable version is determined by the accuracy of the internal voltage reference, the controller topology, and the accuracy of the external resistor. The reference voltage has an accuracy of  $\pm 4\%$  over line, load, and temperature. The controller switches between fixed frequency and pulse-skip mode, depending on load current. This adds an offset to the output voltage that is equivalent to 1% of  $V_O$ . The tolerance of the resistors in the feedback divider determine the total system accuracy.

### Parameter Measurement Information



#### List of Components:

IC1: Only Fixed Output Versions  
 (Unless Otherwise Noted)

L1: SUMIDA CDRH6D38 – 100

C<sub>IN</sub>: X7R/X5R Ceramic

C<sub>OUT</sub>: X7R/X5R Ceramic

Figure 1. Circuit Used for Typical Characteristics Measurements

## Typical Characteristics

### Table of Graphs

		FIGURE
Maximum output current	vs Input voltage for $V_O = 2.5\text{ V}, 3.3\text{ V}$	3
	vs Input voltage for $V_O = 1.5\text{ V}, 1.8\text{ V}$	4
Efficiency	vs Output current for $V_I = 1.2\text{ V}, V_O = 1.5\text{ V}, L1 = \text{Sumida CDR74} - 10\text{ }\mu\text{H}$	5
	vs Output current for $V_I = 1.2\text{ V}, V_O = 2.5\text{ V}, L1 = \text{Sumida CDR74} - 10\text{ }\mu\text{H}$	6
	vs Output current for $V_{IN} = 1.2\text{ V}, V_O = 3.3\text{ V}, L1 = \text{Sumida CDR74} - 10\text{ }\mu\text{H}$	7
	vs Output current for $V_I = 2.4\text{ V}, V_O = 3.3\text{ V}, L1 = \text{Sumida CDR74} - 10\text{ }\mu\text{H}$	8
	vs Input voltage for $I_O = 10\text{ mA}, I_O = 100\text{ mA}, I_O = 200\text{ mA}, V_O = 3.3\text{ V}, L1 = \text{Sumida CDR74} - 10\text{ }\mu\text{H}$	9
	TPS61016, $V_{BAT} = 1.2\text{ V}, I_O = 100\text{ mA}$	10
	Sumida CDRH6D38 - 10 $\mu\text{H}$	
	Sumida CDRH5D18 - 10 $\mu\text{H}$	
	Sumida CDRH74 - 10 $\mu\text{H}$	
	Sumida CDRH74B - 10 $\mu\text{H}$	
	Coilcraft DS 1608C - 10 $\mu\text{H}$	
	Coilcraft DO 1608C - 10 $\mu\text{H}$	
	Coilcraft DO 3308P - 10 $\mu\text{H}$	
	Coilcraft DS 3316 - 10 $\mu\text{H}$	
	Coiltronics UP1B - 10 $\mu\text{H}$	
	Coiltronics UP2B - 10 $\mu\text{H}$	
	Murata LQS66C - 10 $\mu\text{H}$	
	Murata LQN6C - 10 $\mu\text{H}$	
	TDK SLF 7045 - 10 $\mu\text{H}$	
TDK SLF 7032 - 10 $\mu\text{H}$		
Output voltage	vs Output current TPS61011	11
	vs Output current TPS61013	12
	vs Output current TPS61016	13
Minimum supply start-up voltage	vs Load resistance	14
No-load supply current	vs Input voltage	15
Shutdown supply current	vs Input voltage	16
Switch current limit	vs Output voltage	17
Waveforms	Output voltage (ripple) in continuous mode/Inductor current	18
	Output voltage (ripple) in discontinuous mode/Inductor current	19
	Load transient response for output current step of 50 mA to 100 mA	20
	Line transient response for supply voltage step from 1.08 V to 1.32 V at $I_O = 100\text{ mA}$	21
	Converter start-up time after enable	22

**TYPICAL CHARACTERISTICS**

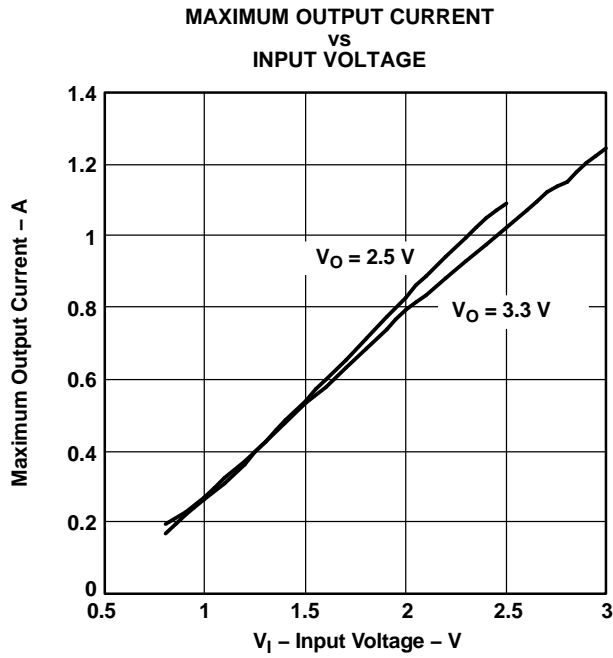


Figure 2.

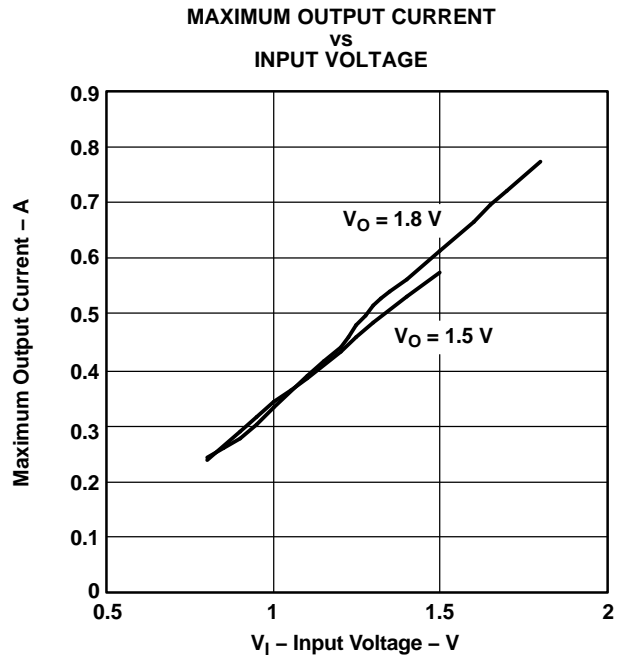


Figure 3.

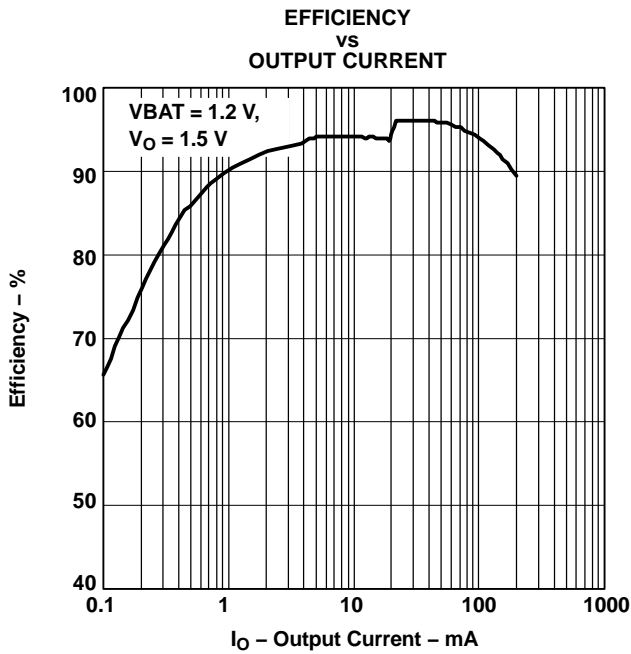


Figure 4.

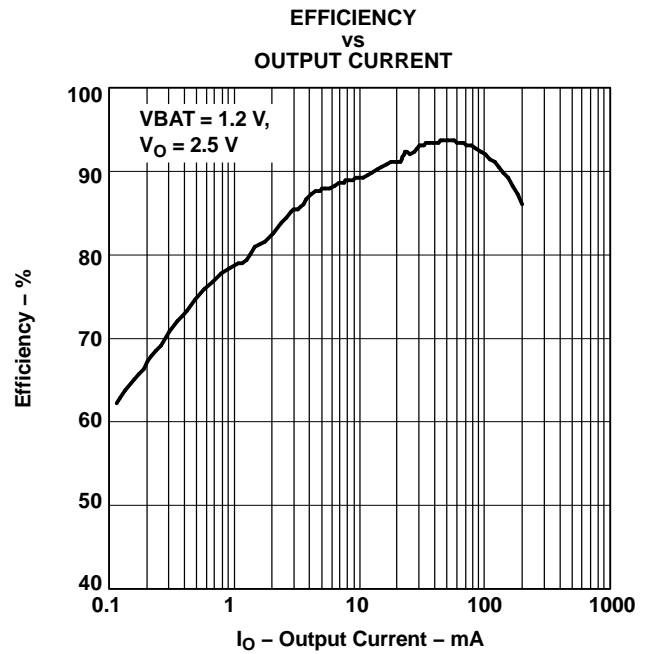
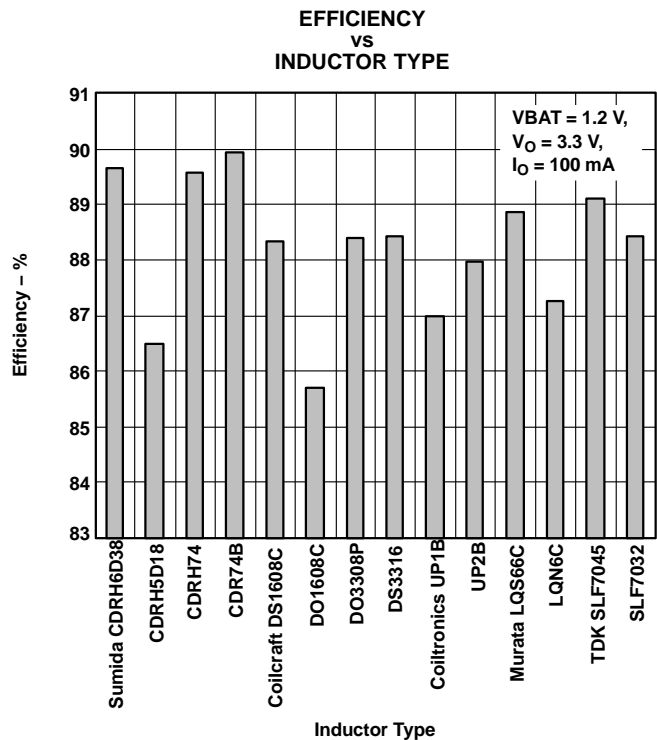
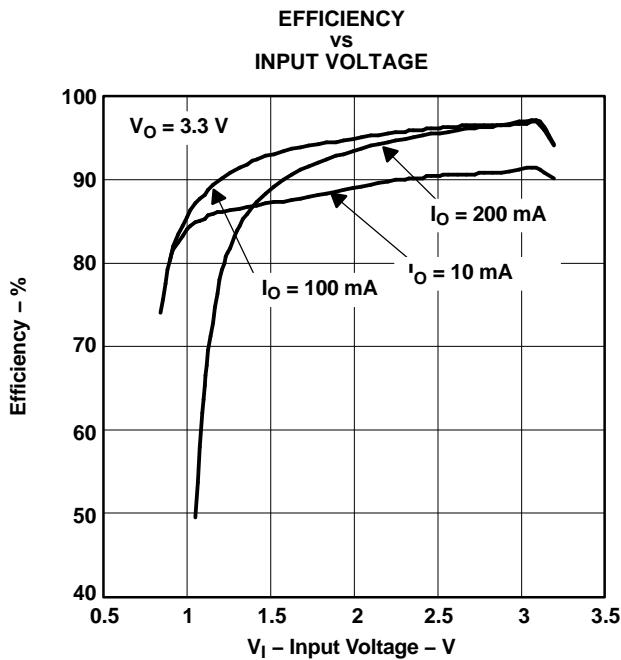
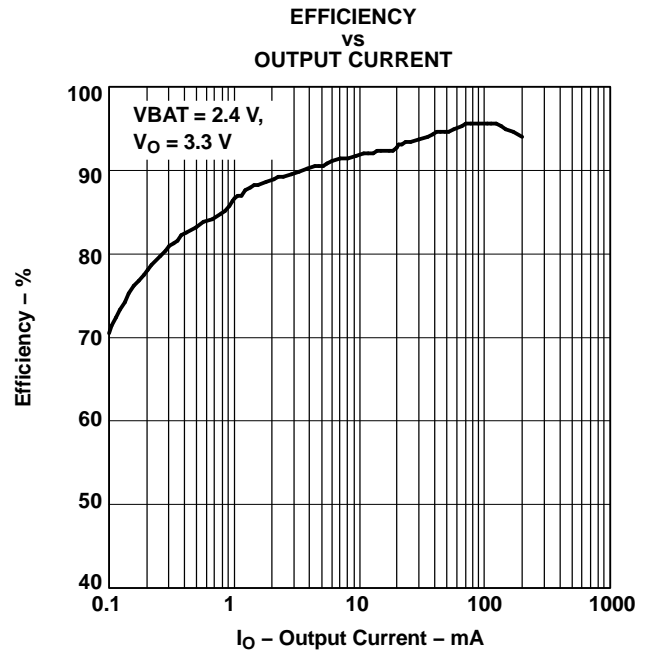
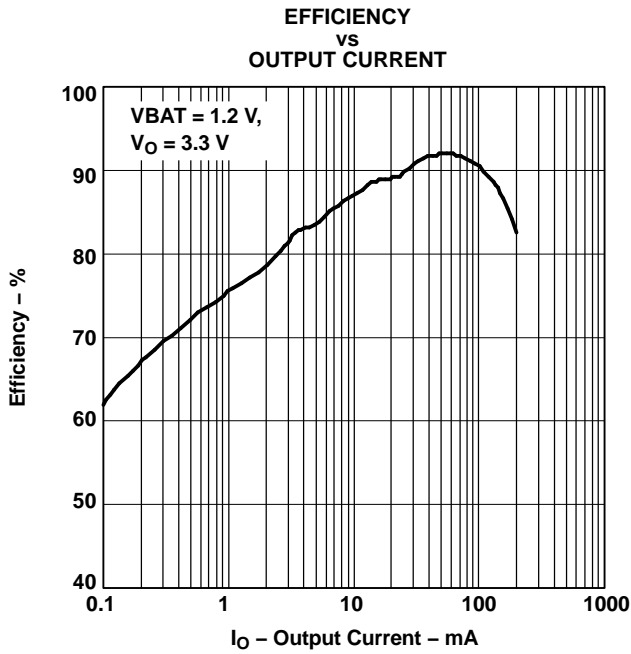


Figure 5.

**TYPICAL CHARACTERISTICS (continued)**



**TYPICAL CHARACTERISTICS (continued)**

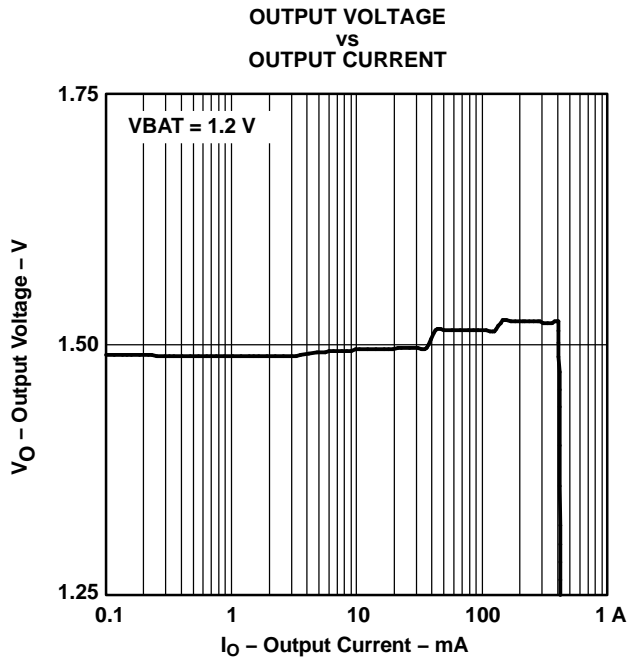


Figure 10.

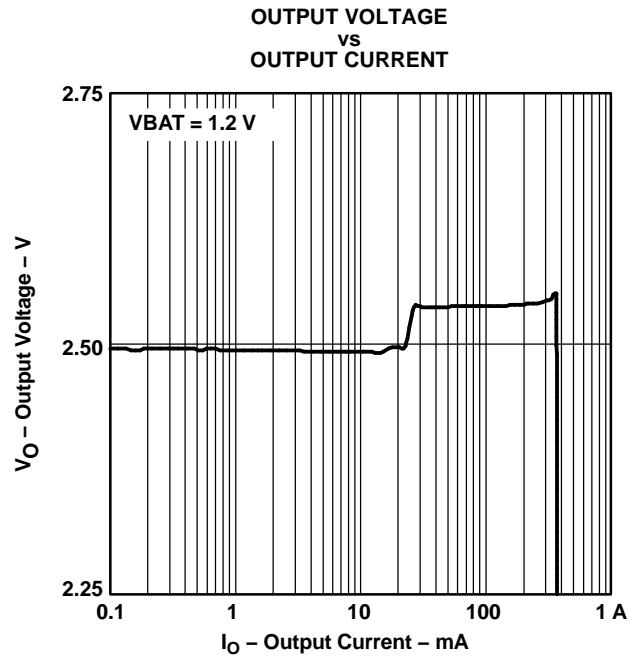


Figure 11.

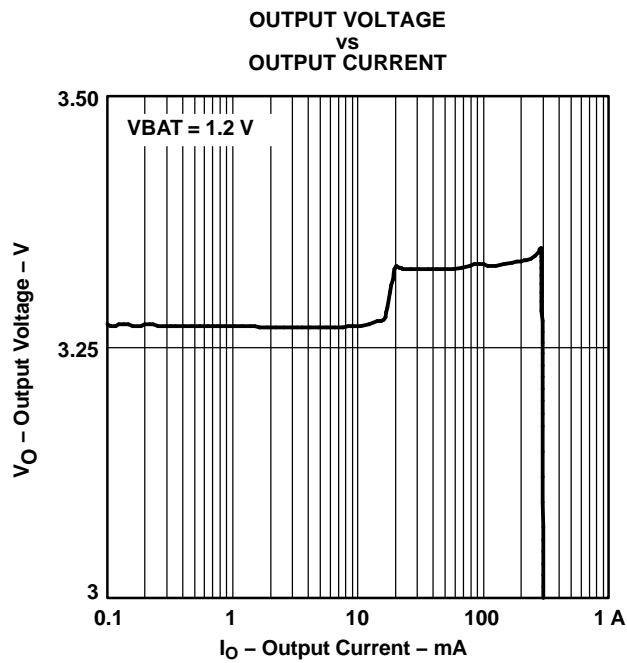


Figure 12.

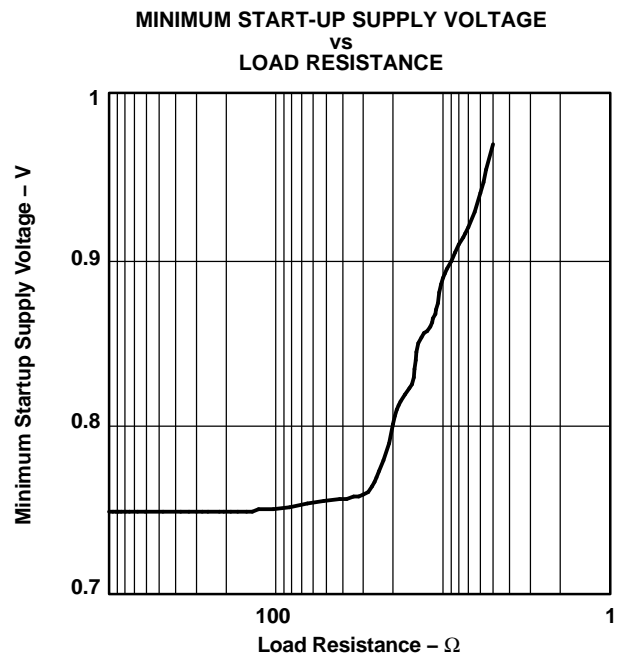


Figure 13.

**TYPICAL CHARACTERISTICS (continued)**

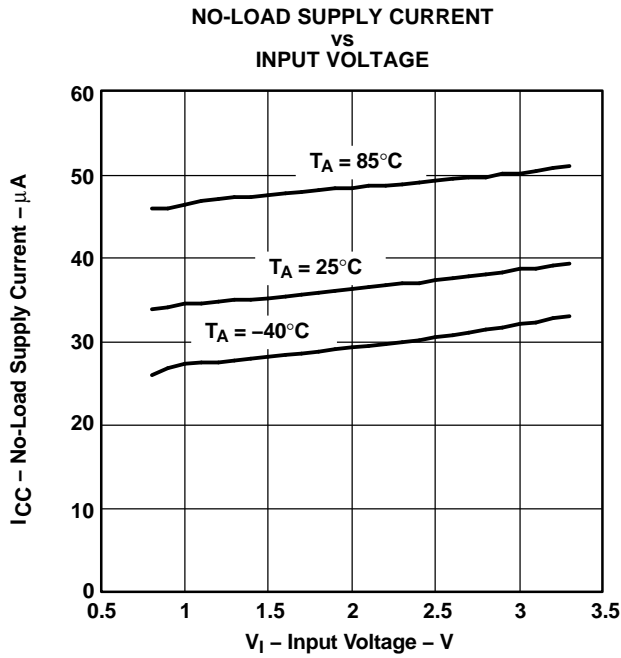


Figure 14.

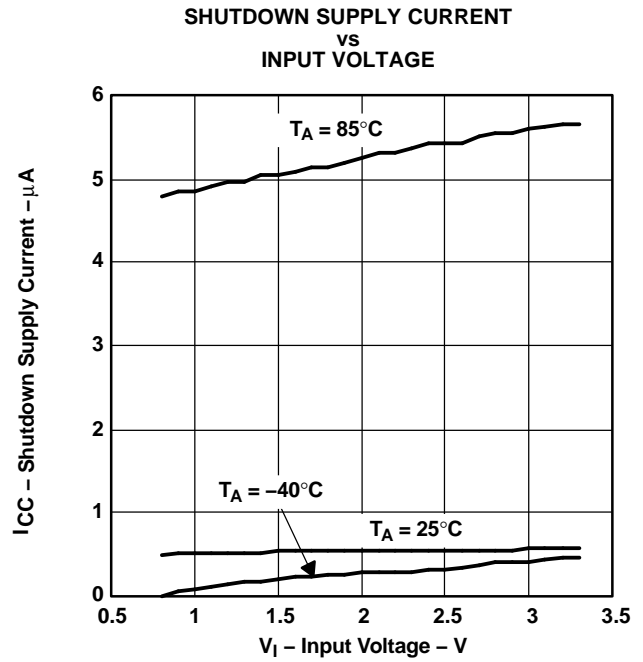


Figure 15.

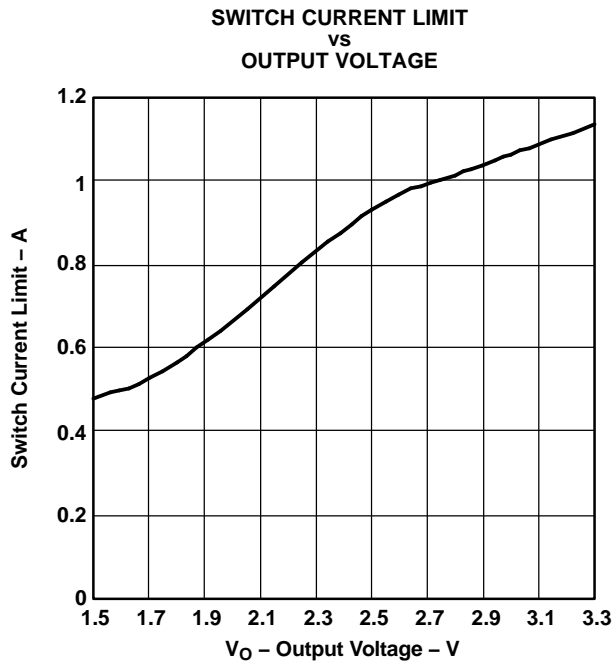


Figure 16.

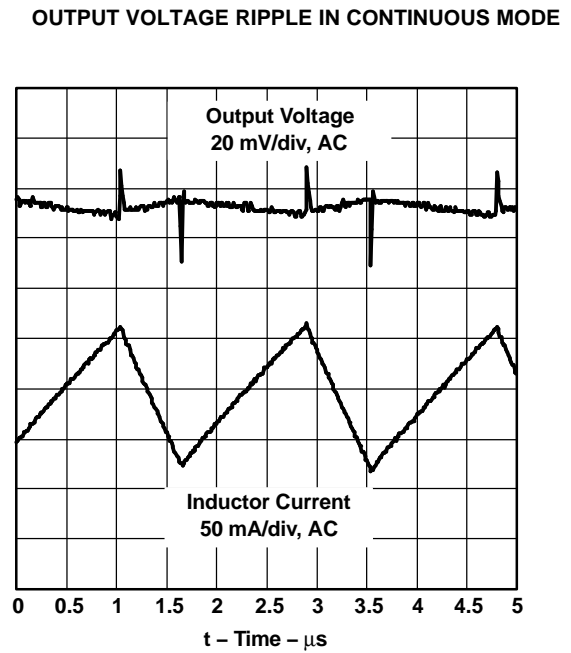


Figure 17.

**TYPICAL CHARACTERISTICS (continued)**

**OUTPUT VOLTAGE RIPPLE IN DISCONTINUOUS MODE**

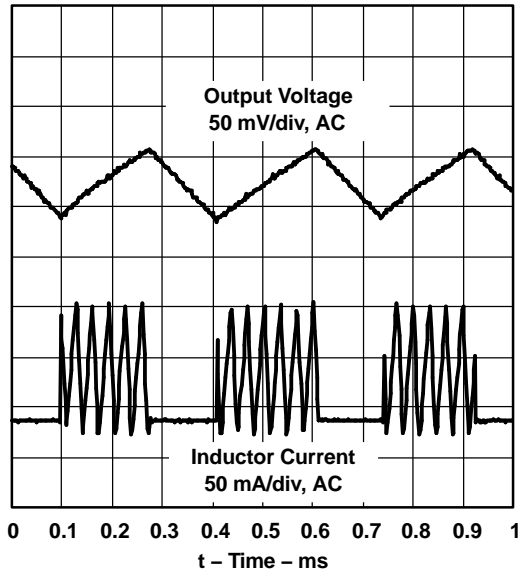


Figure 18.

**LOAD TRANSIENT RESPONSE**

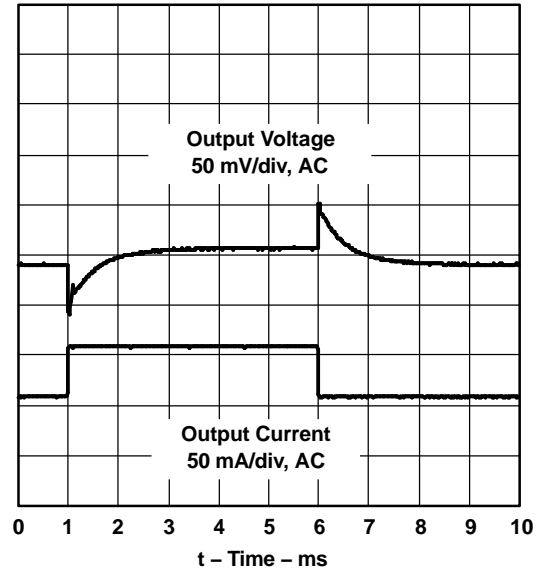


Figure 19.

**LINE TRANSIENT RESPONSE**

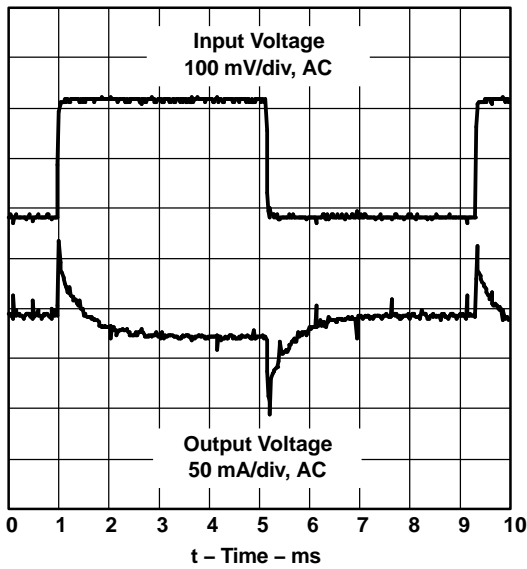


Figure 20.

**CONVERTER START-UP TIME AFTER ENABLE**

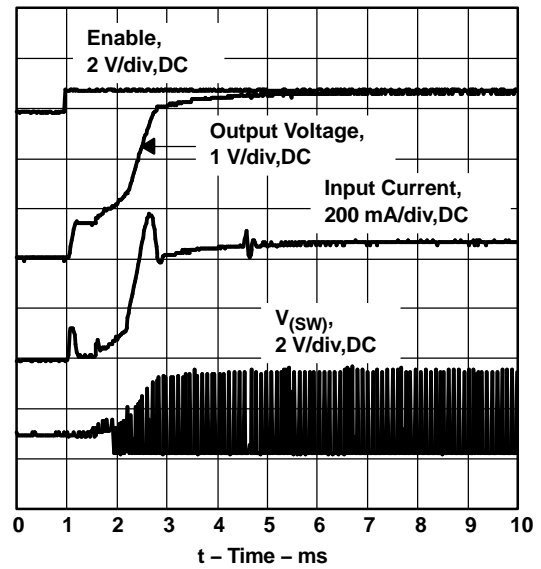


Figure 21.

## DESIGN PROCEDURE

The TPS6101x boost converter family is intended for systems that are powered by a single-cell NiCd or NiMH battery with a typical terminal voltage between 0.9 V to 1.6 V. It can also be used in systems that are powered by two-cell NiCd or NiMH batteries with a typical stack voltage between 1.8 V and 3.2 V. Additionally, single- or dual-cell, primary and secondary alkaline battery cells can be the power source in systems where the TPS6101x is used.

### Programming the TPS61010 Adjustable Output Voltage Device

The output voltage of the TPS61010 can be adjusted with an external resistor divider. The typical value of the voltage on the FB pin is 500 mV in fixed frequency operation and 485 mV in the power-save operation mode. The maximum allowed value for the output voltage is 3.3 V. The current through the resistive divider should be about 100 times greater than the current into the FB pin. The typical current into the FB pin is 0.01  $\mu$ A, and the voltage across R4 is typically 500 mV. Based on those two values, the recommended value for R4 is in the range of 500 k $\Omega$  in order to set the divider current at 1  $\mu$ A. From that, the value of resistor R3, depending on the needed output voltage ( $V_O$ ), can be calculated using Equation 1.

$$R3 = R4 \times \left( \frac{V_O}{V_{FB}} - 1 \right) = 500 \text{ k}\Omega \times \left( \frac{V_O}{500 \text{ mV}} - 1 \right) \quad (1)$$

If, as an example, an output voltage of 2.5 V is needed, a 2-M $\Omega$  resistor should be chosen for R3.

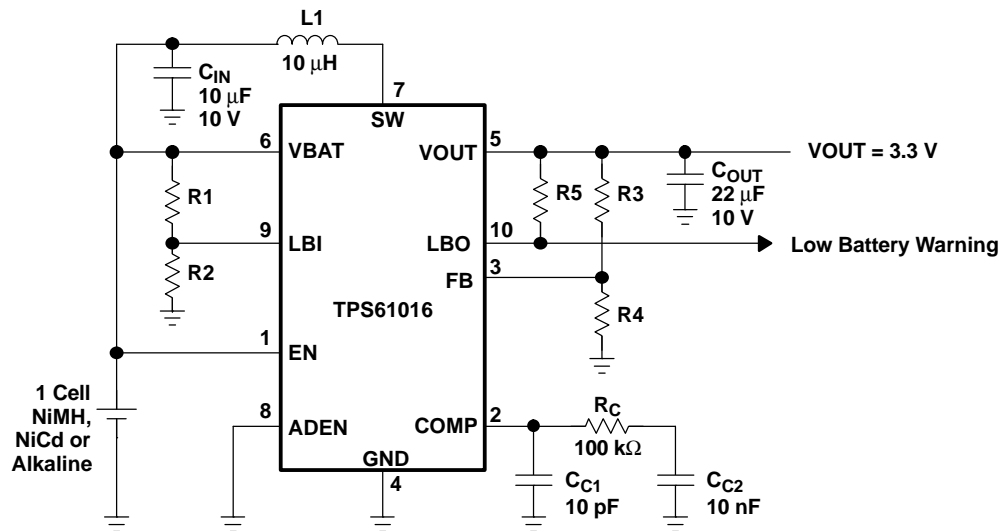


Figure 22. Typical Application Circuit for Adjustable Output Voltage Option

The output voltage of the adjustable output voltage version changes with the output current. Due to device-internal ground shift, which is caused by the high switch current, the internal reference voltage and the voltage on the FB pin increases with increasing output current. Since the output voltage follows the voltage on the FB pin, the output voltage rises as well with a rate of 1 mV per 1-mA output current increase. Additionally, when the converter goes into pulse-skip mode at output currents around 5 mA and lower, the output voltage drops due to the hysteresis of the controller. This hysteresis is about 15 mV, measured on the FB pin.

### programming the low battery comparator threshold voltage

The current through the resistive divider should be about 100 times greater than the current into the LBI pin. The typical current into the LBI pin is 0.01  $\mu$ A, the voltage across R2 is equal to the reference voltage that is generated on-chip, which has a value of 500 mV  $\pm$ 15 mV. The recommended value for R2 is therefore in the range of 500 k $\Omega$ . From that, the value of resistor R1, depending on the desired minimum battery voltage  $V_{BAT}$ , can be calculated using Equation 2.

$$R1 = R2 \times \left( \frac{V_{BAT}}{V_{REF}} - 1 \right) = 500 \text{ k}\Omega \times \left( \frac{V_{BAT}}{500 \text{ mV}} - 1 \right) \quad (2)$$

For example, if the low-battery detection circuit should flag an error condition on the LBO output pin at a battery voltage of 1 V, a resistor in the range of 500 kΩ should be chosen for R1. The output of the low battery comparator is a simple open-drain output that goes active low if the battery voltage drops below the programmed threshold voltage on LBI. The output requires a pullup resistor with a recommended value of 1 MΩ, and should only be pulled up to the V<sub>O</sub>. If not used, the LBO pin can be left floating or tied to GND.

### inductor selection

A boost converter normally requires two main passive components for storing energy during the conversion. A boost inductor is required and a storage capacitor at the output. To select the boost inductor, it is recommended to keep the possible peak inductor current below the current limit threshold of the power switch in the chosen configuration. For example, the current limit threshold of the TPS61010's switch is 1100 mA at an output voltage of 3.3 V. The highest peak current through the inductor and the switch depends on the output load, the input (V<sub>BAT</sub>), and the output voltage (V<sub>O</sub>). Estimation of the maximum average inductor current can be done using [Equation 3](#).

$$I_L = I_{OUT} \times \frac{V_O}{V_{BAT} \times 0.8} \quad (3)$$

For example, for an output current of 100 mA at 3.3 V, at least 515-mA of current flows through the inductor at a minimum input voltage of 0.8 V.

The second parameter for choosing the inductor is the desired current ripple in the inductor. Normally, it is advisable to work with a ripple of less than 20% of the average inductor current. A smaller ripple reduces the magnetic hysteresis losses in the inductor, as well as output voltage ripple and EMI. But in the same way, regulation time at load changes rises. In addition, a larger inductor increases the total system costs.

With those parameters, it is possible to calculate the value for the inductor by using [Equation 4](#).

$$L = \frac{V_{BAT} \times (V_{OUT} - V_{BAT})}{\Delta I_L \times f \times V_{xOUT}} \quad (4)$$

Parameter 7 is the switching frequency and Δ I<sub>L</sub> is the ripple current in the inductor, i.e., 20% × I<sub>L</sub>.

In this example, the desired inductor has the value of 12 μH. With this calculated value and the calculated currents, it is possible to choose a suitable inductor. Care must be taken that load transients and losses in the circuit can lead to higher currents as estimated in [Equation 3](#). Also, the losses in the inductor caused by magnetic hysteresis losses and copper losses are a major parameter for total circuit efficiency.

The following inductor series from different suppliers were tested. All work with the TPS6101x converter within their specified parameters:

**Table 1. Recommended Inductors**

VENDOR	RECOMMENDED INDUCTOR SERIES
Sumida	Sumida CDR74B
	Sumida CDRH74
	Sumida CDRH5D18
	Sumida CDRH6D38
Coilcraft	Coilcraft DO 1608C
	Coilcraft DS 1608C
	Coilcraft DS 3316
	Coilcraft DT D03308P
Coiltronics	Coiltronics UP1B
	Coiltronics UP2B

**Table 1. Recommended Inductors (continued)**

VENDOR	RECOMMENDED INDUCTOR SERIES
Murata	Murata LQS66C
	Murata LQN6C
TDK	TDK SLF 7045
	TDK SLF 7032

### capacitor selection

The major parameter necessary to define the output capacitor is the maximum allowed output voltage ripple of the converter. This ripple is determined by two parameters of the capacitor, the capacitance and the ESR. It is possible to calculate the minimum capacitance needed for the defined ripple, supposing that the ESR is zero, by using [Equation 5](#).

$$C_{\min} = \frac{I_{\text{OUT}} \times (V_{\text{OUT}} - V_{\text{BAT}})}{f \times \Delta V \times V_{\text{OUT}}} \quad (5)$$

Parameter  $f$  is the switching frequency and  $\Delta V$  is the maximum allowed ripple.

With a chosen ripple voltage of 15 mV, a minimum capacitance of 10  $\mu\text{F}$  is needed. The total ripple is larger due to the ESR of the output capacitor. This additional component of the ripple can be calculated using [Equation 6](#).

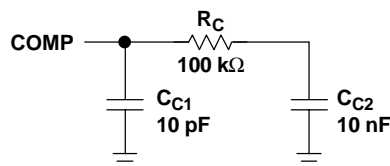
$$\Delta V_{\text{ESR}} = I_{\text{OUT}} \times R_{\text{ESR}} \quad (6)$$

An additional ripple of 30 mV is the result of using a tantalum capacitor with a low ESR of 300  $\text{m}\Omega$ . The total ripple is the sum of the ripple caused by the capacitance and the ripple caused by the ESR of the capacitor. In this example, the total ripple is 45 mV. It is possible to improve the design by enlarging the capacitor or using smaller capacitors in parallel to reduce the ESR or by using better capacitors with lower ESR, like ceramics. For example, a 10  $\mu\text{F}$  ceramic capacitor with an ESR of 50  $\text{m}\Omega$  is used on the evaluation module (EVM). Tradeoffs must be made between performance and costs of the converter circuit.

A 10 $\mu\text{F}$  input capacitor is recommended to improve transient behavior of the regulator. A ceramic capacitor or a tantalum capacitor with a 100 nF ceramic capacitor in parallel placed close to the IC is recommended.

### Compensation of the Control Loop

An R/C/C network must be connected to the COMP pin in order to stabilize the control loop of the converter. Both the pole generated by the inductor L1 and the zero caused by the ESR and capacitance of the output capacitor must be compensated. The network shown in [Figure 5](#) satisfies these requirements.



**Figure 23. Compensation of Control Loop**

Resistor  $R_C$  and capacitor  $C_{C2}$  depend on the chosen inductance. For a 10  $\mu\text{H}$  inductor, the capacitance of  $C_{C2}$  should be chosen to 10 nF, or in other words, if the inductor is  $\text{XX}\mu\text{H}$ , the chosen compensation capacitor should be  $\text{XX}$  nF, the same number value. The value of the compensation resistor is then chosen based on the requirement to have a time constant of 1 ms, for the R/C network  $R_C$  and  $C_{C2}$ , hence for a 33 nF capacitor, a 33 k $\Omega$  resistor should be chosen for  $R_C$ .

Capacitor  $C_{C1}$  depends on the ESR and capacitance value of the output capacitor, and on the value chosen for  $R_C$ . Its value is calculated using [Equation 7](#).

$$C_{C1} = \frac{C_{OUT} \times ESR_{COUT}}{R_C} \quad (7)$$

For a selected output capacitor of 22 μF with an ESR of 0.2Ω , an R<sub>C</sub> of 33 kΩ, the value of C<sub>C1</sub> is in the range of 100 pF.

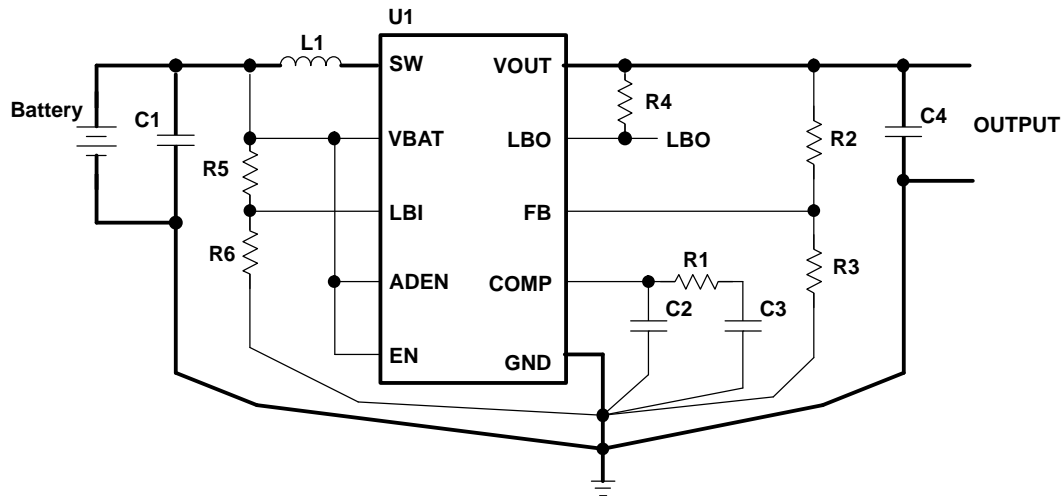
**Table 2. Recommended Compensation Components**

INDUCTOR[μH]	OUTPUT CAPACITOR		RC[kΩ]	CC1[pF]	CC2[nF]
	CAPACITANCE[μF]	ESR[Ω]			
33	22	0.2	33	120	33
22	22	0.3	47	150	22
10	22	0.4	100	100	10
10	10	0.1	100	10	10

### Layout Considerations

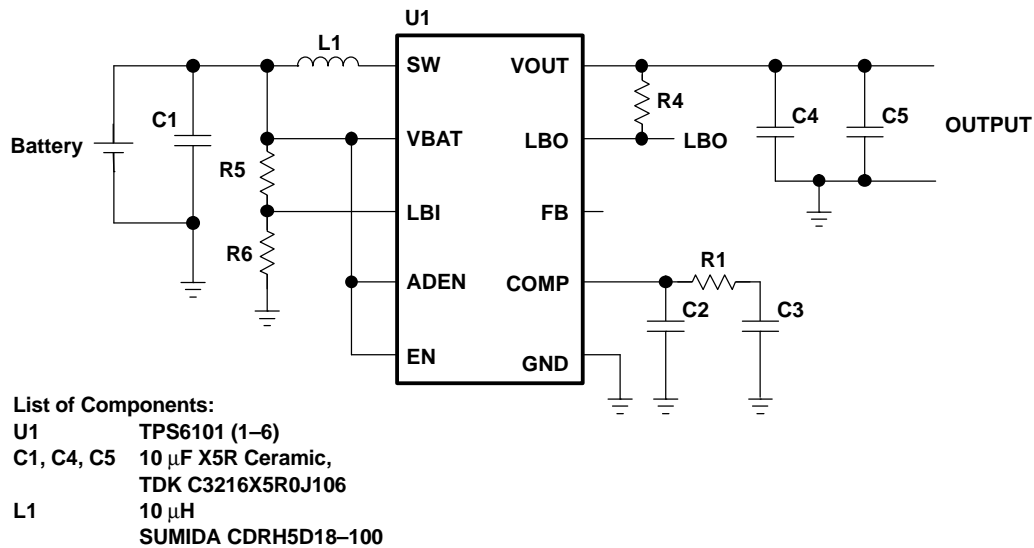
As for all switching power supplies, the layout is an important step in the design, especially at high peak currents and high switching frequencies. If the layout is not carefully done, the regulator could show stability problems as well as EMI problems.

Therefore, use wide and short traces for the main current path as indicated in **bold** in Figure 24. The input capacitor, output capacitor, and the inductor should be placed as close as possible to the IC. Use a common ground node as shown in Figure 24 to minimize the effects of ground noise. The compensation circuit and the feedback divider should be placed as close as possible to the IC. To layout the control ground, it is recommended to use short traces as well, separated from the power ground traces. Connect both grounds close to the ground pin of the IC as indicated in the layout diagram in Figure 24. This avoids ground shift problems, which can occur due to superimposition of power ground current and control ground current.

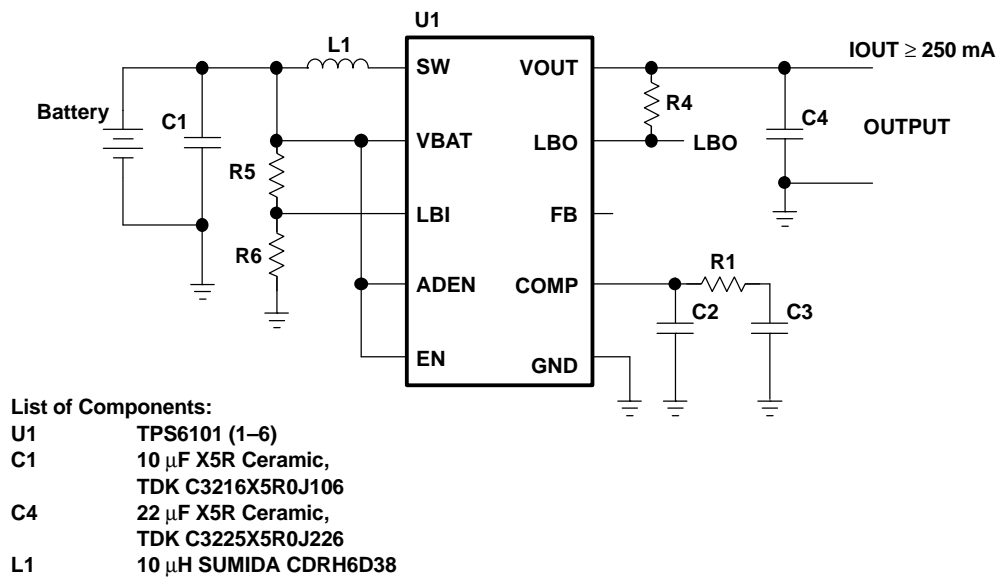


**Figure 24. Layout Diagram**

### APPLICATION INFORMATION

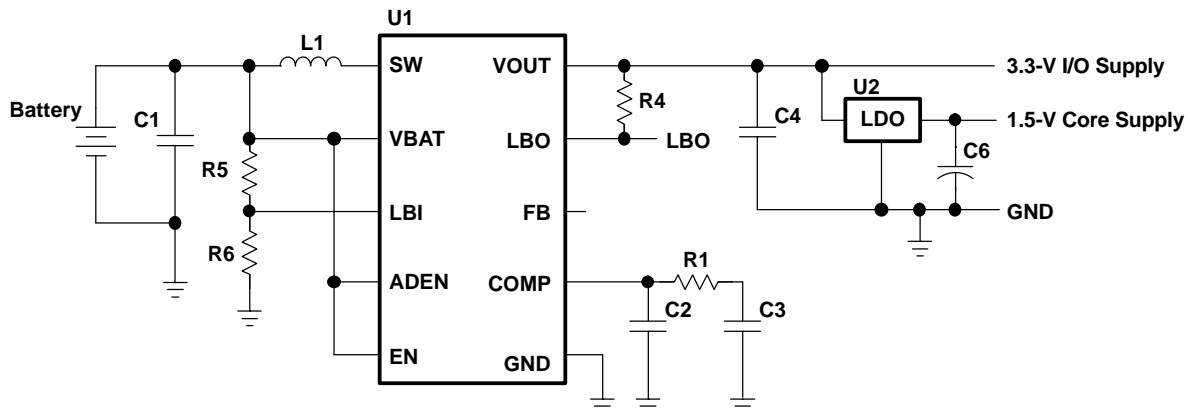


**Figure 25. 1,8 mm Maximum Height Power Supply With Single Battery Cell Input Using Low Profile Components**



**Figure 26. 250-mA Power Supply With Two Battery Cell Input**

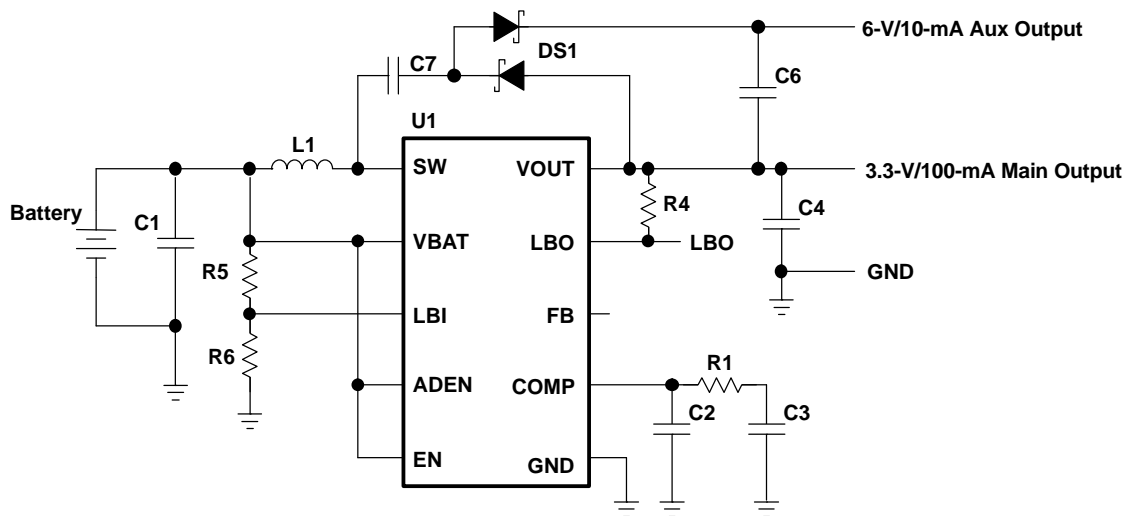
**APPLICATION INFORMATION (continued)**



**List of Components:**

- U1        TPS61016
- U2        TPS76915
- C1        10  $\mu$ F X5R Ceramic,  
          TDK C3216X5R0J106
- C4        22  $\mu$ F X5R Ceramic,  
          TDK C3225X5R0J226
- L1        10  $\mu$ H SUMIDA CDRH6D38

**Figure 27. Dual Output Voltage Power Supply for DSPs**

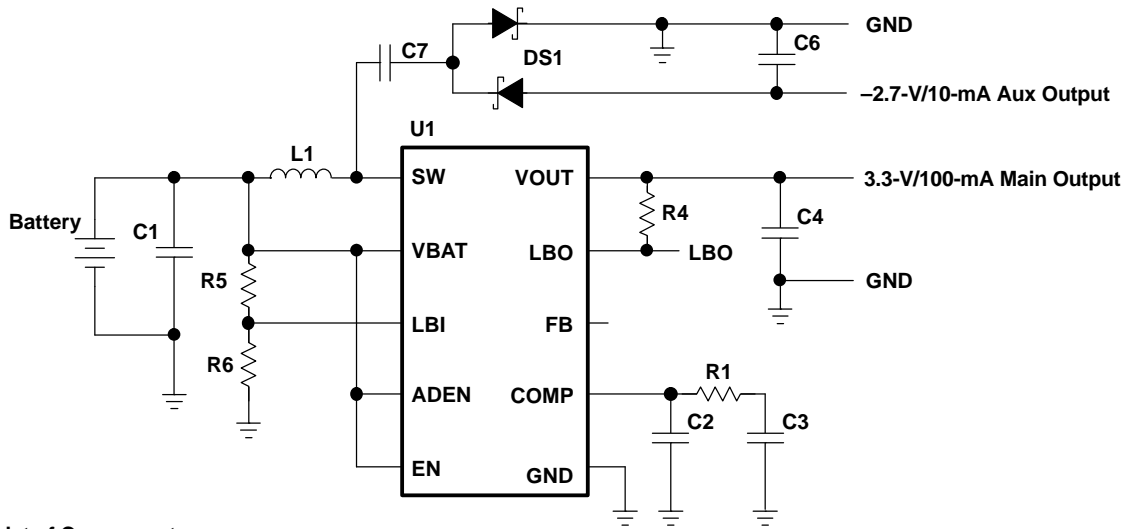


**List of Components:**

- U1        TPS61016
- DS1       BAT54S
- C1        10  $\mu$ F X5R Ceramic,  
          TDK C3216X5R0J106
- C4        22  $\mu$ F X5R Ceramic,  
          TDK C3225X5R0J226,
- C6        1  $\mu$ F X5R Ceramic,
- C7        0.1  $\mu$ F X5R Ceramic,
- L1        10  $\mu$ H SUMIDA CDRH6D38–100

**Figure 28. Power Supply With Auxiliary Positive Output Voltage**

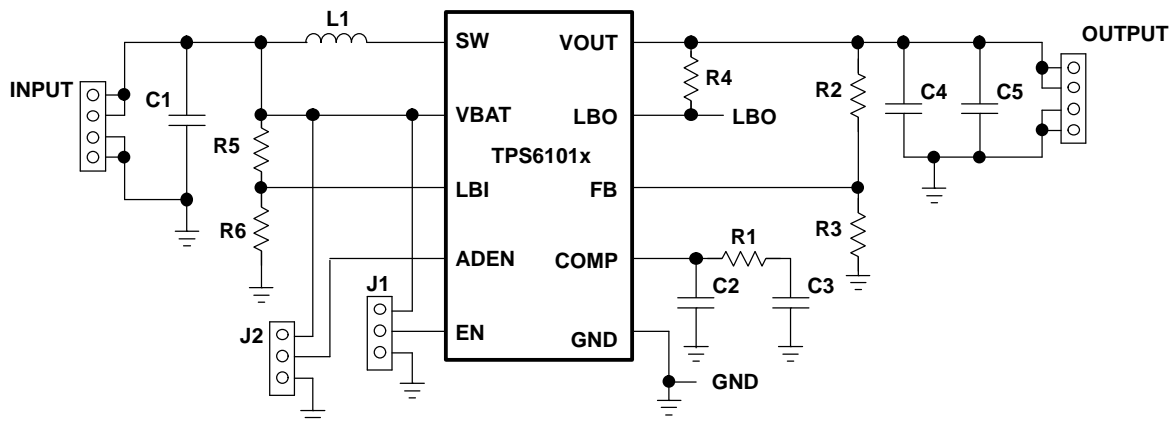
**APPLICATION INFORMATION (continued)**



**List of Components:**

- U1      TPS61016
- DS1     BAT54S
- C1      10  $\mu$ F X5R Ceramic,  
          TDK C3216X5R0J106
- C4      22  $\mu$ F X5R Ceramic,  
          TDK C3225X5R0J226,
- C6      1  $\mu$ F X5R Ceramic,
- C7      0.1  $\mu$ F X5R Ceramic,
- L1      10  $\mu$ H SUMIDA CDRH6D38-100

**Figure 29. Power Supply With Auxiliary Negative Output Voltage**



**Figure 30. TPS6101x EVM Circuit Diagram**

APPLICATION INFORMATION (continued)

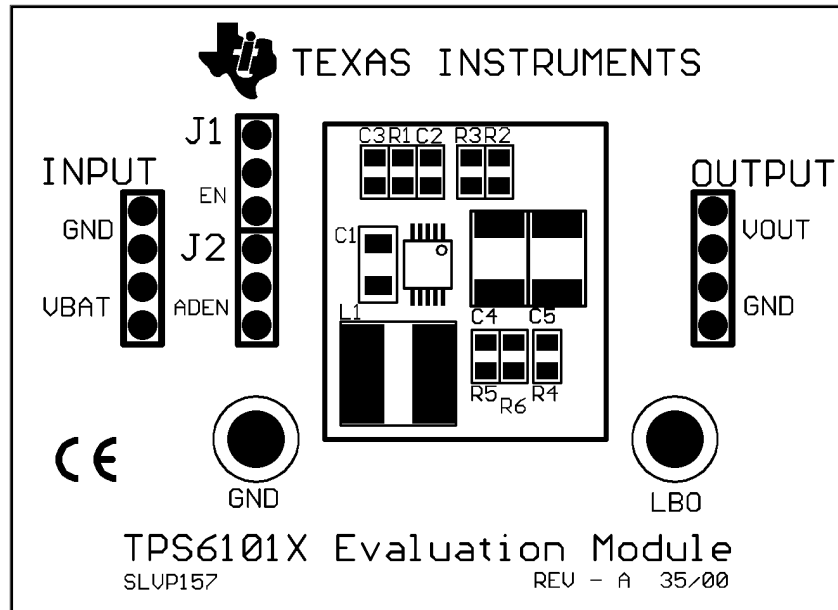


Figure 31. TPS6101x EVM Component Placement (actual size: 55,9 mm x 40,6 mm)

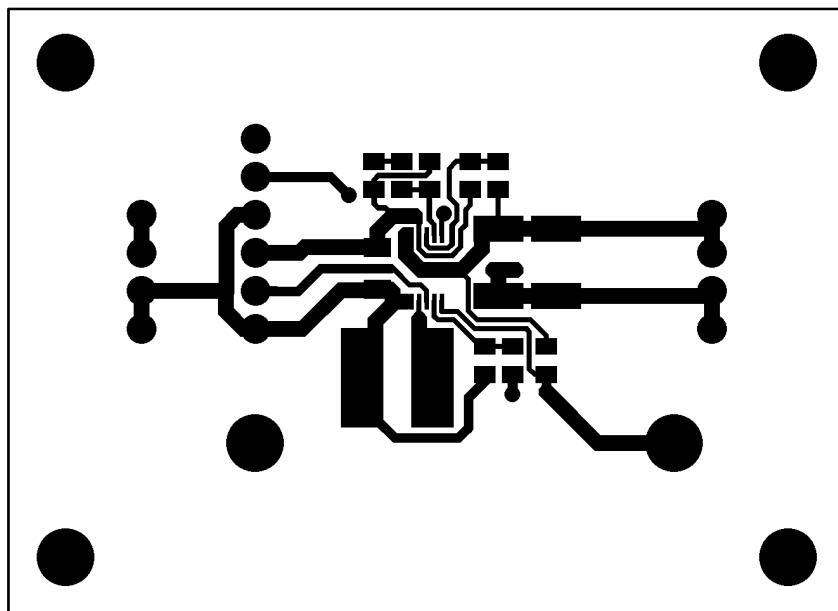
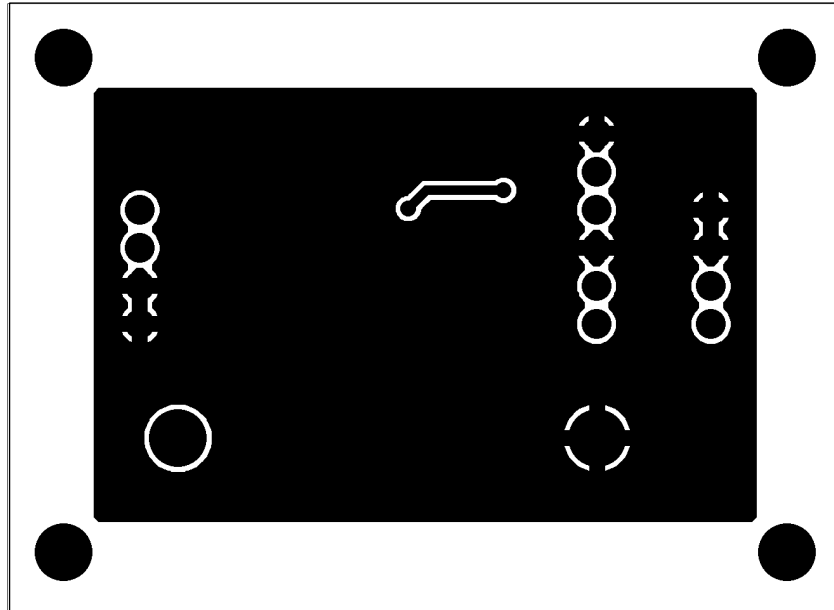


Figure 32. TPS6101x EVM Top Layer Layout (actual size: 55,9 mm x 40,6 mm)

**APPLICATION INFORMATION (continued)**



**Figure 33. TPS6101x EVM Bottom Layer Layout (actual size: 55,9 mm x 40,6 mm)**

**THERMAL INFORMATION**

Implementation of integrated circuits in low-profile and fine-pitch surface-mount packages typically requires special attention to power dissipation. Many system-dependent issues such as thermal coupling, airflow, added heat sinks and convection surfaces, and the presence of other heat-generating components affect the power-dissipation limits of a given component.

Three basic approaches for enhancing thermal performance are:

- Improving the power dissipation capability of the PWB design
- Improving the thermal coupling of the component to the PWB
- Introducing airflow in the system

The maximum junction temperature ( $T_J$ ) of the TPS6101x devices is 125°C. The thermal resistance of the 10-pin MSOP package (DGS) is  $R_{\theta JA} = 294^\circ\text{C/W}$ . Specified regulator operation is assured to a maximum ambient temperature ( $T_A$ ) of 85°C. Therefore, the maximum power dissipation is about 130 mW. More power can be dissipated if the maximum ambient temperature of the application is lower.

$$P_{D(\text{MAX})} = \frac{T_{J(\text{MAX})} - T_A}{R_{\theta JA}} = \frac{125^\circ\text{C} - 85^\circ\text{C}}{294^\circ\text{C/W}} = 136 \text{ mW} \quad (8)$$

**PACKAGING INFORMATION**

Orderable Device	Status <sup>(1)</sup>	Package Type	Package Drawing	Pins	Package Qty	Eco Plan <sup>(2)</sup>	Lead/ Ball Finish	MSL Peak Temp <sup>(3)</sup>	Samples (Requires Login)
TPS61010DGS	ACTIVE	MSOP	DGS	10	80	Green (RoHS & no Sb/Br)	CU NIPDAU	Level-1-260C-UNLIM	
TPS61010DGSG4	ACTIVE	MSOP	DGS	10	80	Green (RoHS & no Sb/Br)	CU NIPDAU	Level-1-260C-UNLIM	
TPS61010DGSR	ACTIVE	MSOP	DGS	10	2500	Green (RoHS & no Sb/Br)	CU NIPDAU	Level-1-260C-UNLIM	
TPS61010DGSRG4	ACTIVE	MSOP	DGS	10	2500	Green (RoHS & no Sb/Br)	CU NIPDAU	Level-1-260C-UNLIM	
TPS61010DRCT	PREVIEW	SON	DRC	10		TBD	Call TI	Call TI	
TPS61011DGS	ACTIVE	MSOP	DGS	10		TBD	Call TI	Call TI	
TPS61011DGSG4	ACTIVE	MSOP	DGS	10		TBD	Call TI	Call TI	
TPS61012DGS	ACTIVE	MSOP	DGS	10	80	Green (RoHS & no Sb/Br)	CU NIPDAU	Level-1-260C-UNLIM	
TPS61012DGSG4	ACTIVE	MSOP	DGS	10	80	Green (RoHS & no Sb/Br)	CU NIPDAU	Level-1-260C-UNLIM	
TPS61012DGSR	ACTIVE	MSOP	DGS	10	2500	Green (RoHS & no Sb/Br)	CU NIPDAU	Level-1-260C-UNLIM	
TPS61012DGSRG4	ACTIVE	MSOP	DGS	10	2500	Green (RoHS & no Sb/Br)	CU NIPDAU	Level-1-260C-UNLIM	
TPS61013DGS	ACTIVE	MSOP	DGS	10	80	Green (RoHS & no Sb/Br)	CU NIPDAUAG	Level-1-260C-UNLIM	
TPS61013DGSG4	ACTIVE	MSOP	DGS	10	80	Green (RoHS & no Sb/Br)	CU NIPDAUAG	Level-1-260C-UNLIM	
TPS61014DGS	ACTIVE	MSOP	DGS	10	80	Green (RoHS & no Sb/Br)	CU NIPDAUAG	Level-1-260C-UNLIM	
TPS61014DGSG4	ACTIVE	MSOP	DGS	10	80	Green (RoHS & no Sb/Br)	CU NIPDAUAG	Level-1-260C-UNLIM	
TPS61014DGSR	ACTIVE	MSOP	DGS	10	2500	Green (RoHS & no Sb/Br)	CU NIPDAUAG	Level-1-260C-UNLIM	
TPS61014DGSRG4	ACTIVE	MSOP	DGS	10	2500	Green (RoHS & no Sb/Br)	CU NIPDAUAG	Level-1-260C-UNLIM	
TPS61015DGS	ACTIVE	MSOP	DGS	10	80	Green (RoHS & no Sb/Br)	CU NIPDAUAG	Level-1-260C-UNLIM	

Orderable Device	Status <sup>(1)</sup>	Package Type	Package Drawing	Pins	Package Qty	Eco Plan <sup>(2)</sup>	Lead/ Ball Finish	MSL Peak Temp <sup>(3)</sup>	Samples (Requires Login)
TPS61015DGSG4	ACTIVE	MSOP	DGS	10	80	Green (RoHS & no Sb/Br)	CU NIPDAUAG	Level-1-260C-UNLIM	
TPS61015DGSR	ACTIVE	MSOP	DGS	10	2500	Green (RoHS & no Sb/Br)	CU NIPDAUAG	Level-1-260C-UNLIM	
TPS61015DGSRG4	ACTIVE	MSOP	DGS	10	2500	Green (RoHS & no Sb/Br)	CU NIPDAUAG	Level-1-260C-UNLIM	
TPS61016DGS	ACTIVE	MSOP	DGS	10	80	Green (RoHS & no Sb/Br)	CU NIPDAUAG	Level-1-260C-UNLIM	
TPS61016DGSG4	ACTIVE	MSOP	DGS	10	80	Green (RoHS & no Sb/Br)	CU NIPDAUAG	Level-1-260C-UNLIM	
TPS61016DGSR	ACTIVE	MSOP	DGS	10	2500	Green (RoHS & no Sb/Br)	CU NIPDAUAG	Level-1-260C-UNLIM	
TPS61016DGSRG4	ACTIVE	MSOP	DGS	10	2500	Green (RoHS & no Sb/Br)	CU NIPDAUAG	Level-1-260C-UNLIM	

<sup>(1)</sup> The marketing status values are defined as follows:

**ACTIVE:** Product device recommended for new designs.

**LIFEBUY:** TI has announced that the device will be discontinued, and a lifetime-buy period is in effect.

**NRND:** Not recommended for new designs. Device is in production to support existing customers, but TI does not recommend using this part in a new design.

**PREVIEW:** Device has been announced but is not in production. Samples may or may not be available.

**OBSOLETE:** TI has discontinued the production of the device.

<sup>(2)</sup> Eco Plan - The planned eco-friendly classification: Pb-Free (RoHS), Pb-Free (RoHS Exempt), or Green (RoHS & no Sb/Br) - please check <http://www.ti.com/productcontent> for the latest availability information and additional product content details.

**TBD:** The Pb-Free/Green conversion plan has not been defined.

**Pb-Free (RoHS):** TI's terms "Lead-Free" or "Pb-Free" mean semiconductor products that are compatible with the current RoHS requirements for all 6 substances, including the requirement that lead not exceed 0.1% by weight in homogeneous materials. Where designed to be soldered at high temperatures, TI Pb-Free products are suitable for use in specified lead-free processes.

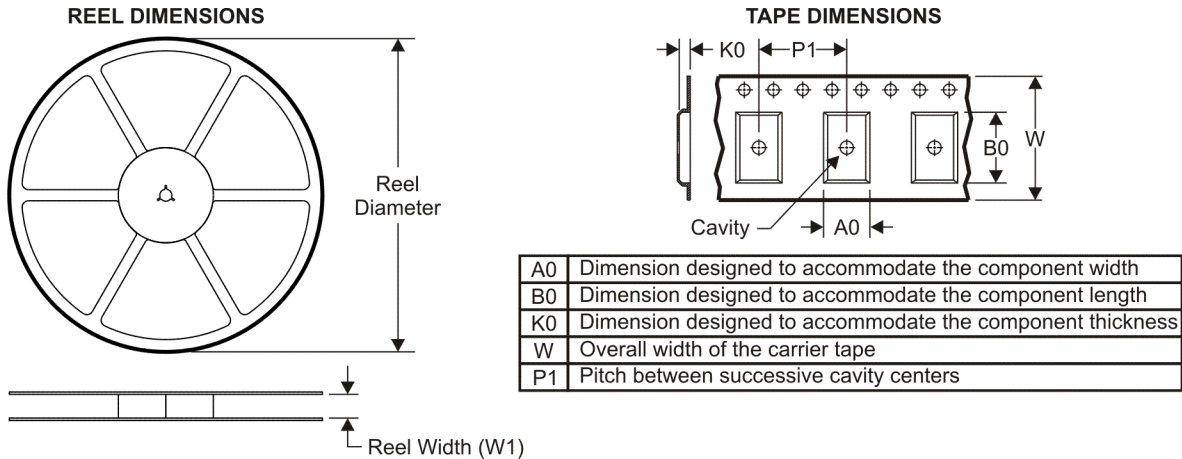
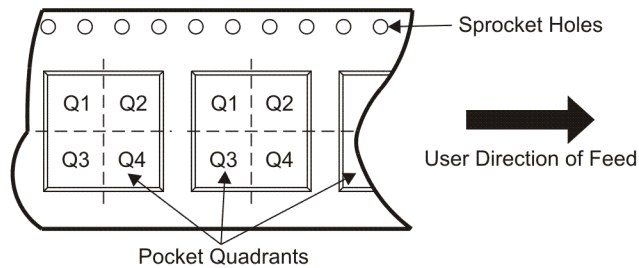
**Pb-Free (RoHS Exempt):** This component has a RoHS exemption for either 1) lead-based flip-chip solder bumps used between the die and package, or 2) lead-based die adhesive used between the die and leadframe. The component is otherwise considered Pb-Free (RoHS compatible) as defined above.

**Green (RoHS & no Sb/Br):** TI defines "Green" to mean Pb-Free (RoHS compatible), and free of Bromine (Br) and Antimony (Sb) based flame retardants (Br or Sb do not exceed 0.1% by weight in homogeneous material)

<sup>(3)</sup> MSL, Peak Temp. -- The Moisture Sensitivity Level rating according to the JEDEC industry standard classifications, and peak solder temperature.

**Important Information and Disclaimer:** The information provided on this page represents TI's knowledge and belief as of the date that it is provided. TI bases its knowledge and belief on information provided by third parties, and makes no representation or warranty as to the accuracy of such information. Efforts are underway to better integrate information from third parties. TI has taken and continues to take reasonable steps to provide representative and accurate information but may not have conducted destructive testing or chemical analysis on incoming materials and chemicals. TI and TI suppliers consider certain information to be proprietary, and thus CAS numbers and other limited information may not be available for release.

In no event shall TI's liability arising out of such information exceed the total purchase price of the TI part(s) at issue in this document sold by TI to Customer on an annual basis.

**TAPE AND REEL INFORMATION**

**QUADRANT ASSIGNMENTS FOR PIN 1 ORIENTATION IN TAPE**


\*All dimensions are nominal

Device	Package Type	Package Drawing	Pins	SPQ	Reel Diameter (mm)	Reel Width W1 (mm)	A0 (mm)	B0 (mm)	K0 (mm)	P1 (mm)	W (mm)	Pin1 Quadrant
TPS61010DGSR	MSOP	DGS	10	2500	330.0	12.4	5.3	3.4	1.4	8.0	12.0	Q1
TPS61012DGSR	MSOP	DGS	10	2500	330.0	12.4	5.3	3.4	1.4	8.0	12.0	Q1
TPS61014DGSR	MSOP	DGS	10	2500	330.0	12.4	5.3	3.4	1.4	8.0	12.0	Q1
TPS61015DGSR	MSOP	DGS	10	2500	330.0	12.4	5.3	3.4	1.4	8.0	12.0	Q1
TPS61016DGSR	MSOP	DGS	10	2500	330.0	12.4	5.3	3.4	1.4	8.0	12.0	Q1

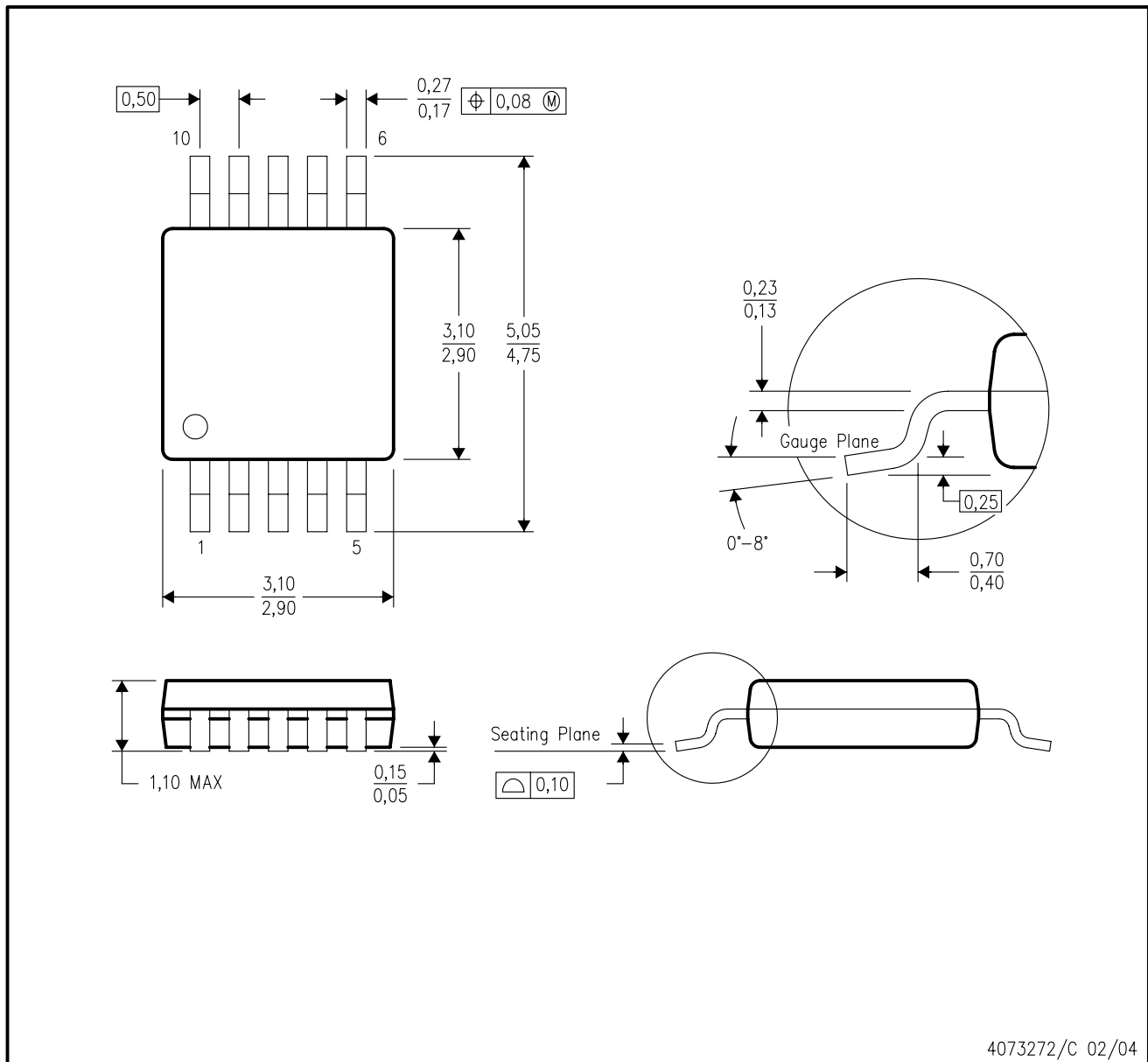
**TAPE AND REEL BOX DIMENSIONS**


\*All dimensions are nominal

Device	Package Type	Package Drawing	Pins	SPQ	Length (mm)	Width (mm)	Height (mm)
TPS61010DGSR	MSOP	DGS	10	2500	346.0	346.0	29.0
TPS61012DGSR	MSOP	DGS	10	2500	346.0	346.0	29.0
TPS61014DGSR	MSOP	DGS	10	2500	346.0	346.0	29.0
TPS61015DGSR	MSOP	DGS	10	2500	346.0	346.0	29.0
TPS61016DGSR	MSOP	DGS	10	2500	346.0	346.0	29.0

DGS (S-PDSO-G10)

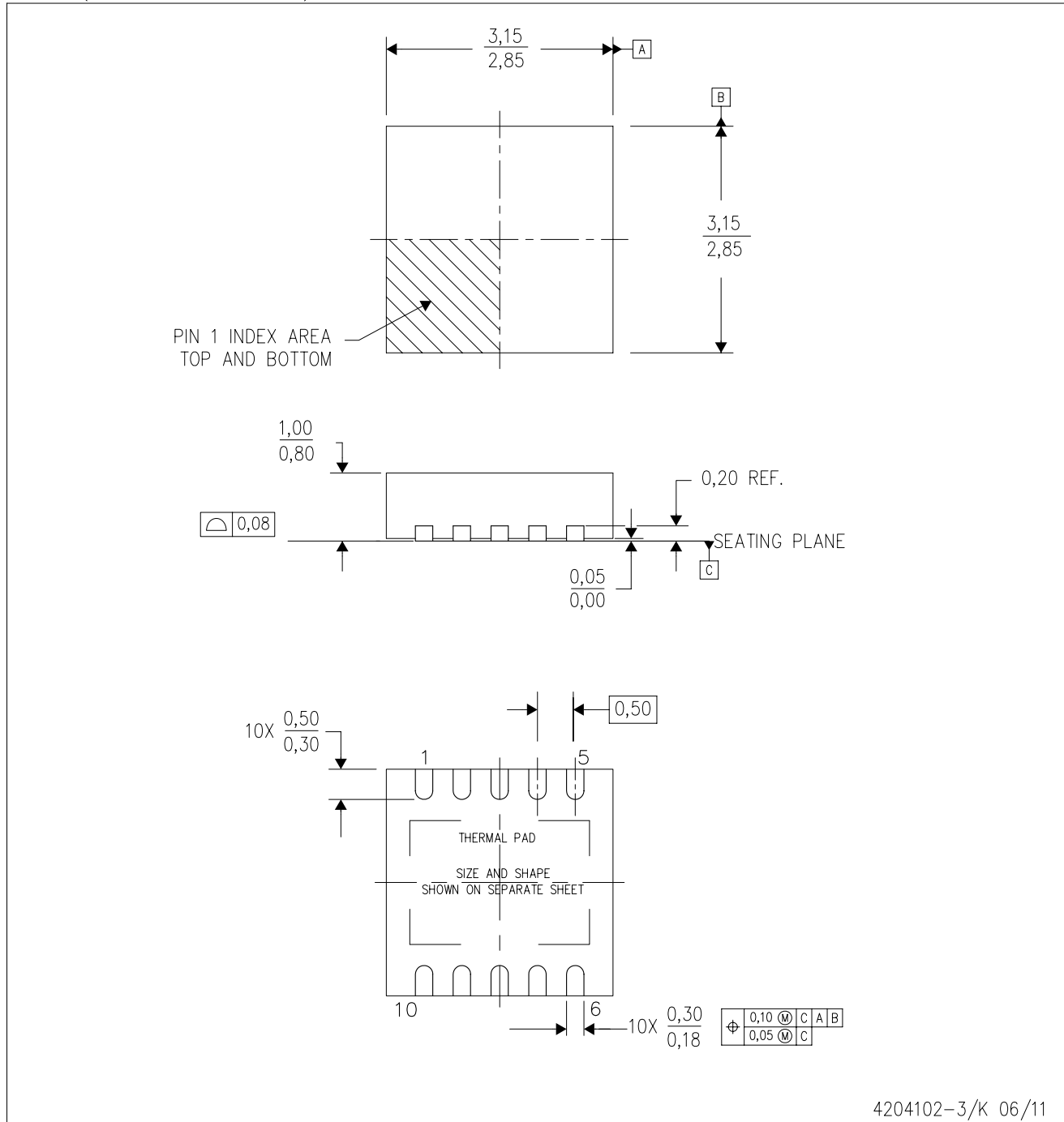
PLASTIC SMALL-OUTLINE PACKAGE



- NOTES:
- A. All linear dimensions are in millimeters.
  - B. This drawing is subject to change without notice.
  - C. Body dimensions do not include mold flash or protrusion.
  - D. Falls within JEDEC MO-187 variation BA.

DRC (S-PVSON-N10)

PLASTIC SMALL OUTLINE NO-LEAD



- NOTES:
- All linear dimensions are in millimeters. Dimensioning and tolerancing per ASME Y14.5M-1994.
  - This drawing is subject to change without notice.
  - Small Outline No-Lead (SON) package configuration.
  - The package thermal pad must be soldered to the board for thermal and mechanical performance, if present.
  - See the additional figure in the Product Data Sheet for details regarding the exposed thermal pad features and dimensions, if present

## IMPORTANT NOTICE

Texas Instruments Incorporated and its subsidiaries (TI) reserve the right to make corrections, modifications, enhancements, improvements, and other changes to its products and services at any time and to discontinue any product or service without notice. Customers should obtain the latest relevant information before placing orders and should verify that such information is current and complete. All products are sold subject to TI's terms and conditions of sale supplied at the time of order acknowledgment.

TI warrants performance of its hardware products to the specifications applicable at the time of sale in accordance with TI's standard warranty. Testing and other quality control techniques are used to the extent TI deems necessary to support this warranty. Except where mandated by government requirements, testing of all parameters of each product is not necessarily performed.

TI assumes no liability for applications assistance or customer product design. Customers are responsible for their products and applications using TI components. To minimize the risks associated with customer products and applications, customers should provide adequate design and operating safeguards.

TI does not warrant or represent that any license, either express or implied, is granted under any TI patent right, copyright, mask work right, or other TI intellectual property right relating to any combination, machine, or process in which TI products or services are used. Information published by TI regarding third-party products or services does not constitute a license from TI to use such products or services or a warranty or endorsement thereof. Use of such information may require a license from a third party under the patents or other intellectual property of the third party, or a license from TI under the patents or other intellectual property of TI.

Reproduction of TI information in TI data books or data sheets is permissible only if reproduction is without alteration and is accompanied by all associated warranties, conditions, limitations, and notices. Reproduction of this information with alteration is an unfair and deceptive business practice. TI is not responsible or liable for such altered documentation. Information of third parties may be subject to additional restrictions.

Resale of TI products or services with statements different from or beyond the parameters stated by TI for that product or service voids all express and any implied warranties for the associated TI product or service and is an unfair and deceptive business practice. TI is not responsible or liable for any such statements.

TI products are not authorized for use in safety-critical applications (such as life support) where a failure of the TI product would reasonably be expected to cause severe personal injury or death, unless officers of the parties have executed an agreement specifically governing such use. Buyers represent that they have all necessary expertise in the safety and regulatory ramifications of their applications, and acknowledge and agree that they are solely responsible for all legal, regulatory and safety-related requirements concerning their products and any use of TI products in such safety-critical applications, notwithstanding any applications-related information or support that may be provided by TI. Further, Buyers must fully indemnify TI and its representatives against any damages arising out of the use of TI products in such safety-critical applications.

TI products are neither designed nor intended for use in military/aerospace applications or environments unless the TI products are specifically designated by TI as military-grade or "enhanced plastic." Only products designated by TI as military-grade meet military specifications. Buyers acknowledge and agree that any such use of TI products which TI has not designated as military-grade is solely at the Buyer's risk, and that they are solely responsible for compliance with all legal and regulatory requirements in connection with such use.

TI products are neither designed nor intended for use in automotive applications or environments unless the specific TI products are designated by TI as compliant with ISO/TS 16949 requirements. Buyers acknowledge and agree that, if they use any non-designated products in automotive applications, TI will not be responsible for any failure to meet such requirements.

Following are URLs where you can obtain information on other Texas Instruments products and application solutions:

### Products

Audio	<a href="http://www.ti.com/audio">www.ti.com/audio</a>
Amplifiers	<a href="http://amplifier.ti.com">amplifier.ti.com</a>
Data Converters	<a href="http://dataconverter.ti.com">dataconverter.ti.com</a>
DLP® Products	<a href="http://www.dlp.com">www.dlp.com</a>
DSP	<a href="http://dsp.ti.com">dsp.ti.com</a>
Clocks and Timers	<a href="http://www.ti.com/clocks">www.ti.com/clocks</a>
Interface	<a href="http://interface.ti.com">interface.ti.com</a>
Logic	<a href="http://logic.ti.com">logic.ti.com</a>
Power Mgmt	<a href="http://power.ti.com">power.ti.com</a>
Microcontrollers	<a href="http://microcontroller.ti.com">microcontroller.ti.com</a>
RFID	<a href="http://www.ti-rfid.com">www.ti-rfid.com</a>
RF/IF and ZigBee® Solutions	<a href="http://www.ti.com/lprf">www.ti.com/lprf</a>

### Applications

Communications and Telecom	<a href="http://www.ti.com/communications">www.ti.com/communications</a>
Computers and Peripherals	<a href="http://www.ti.com/computers">www.ti.com/computers</a>
Consumer Electronics	<a href="http://www.ti.com/consumer-apps">www.ti.com/consumer-apps</a>
Energy and Lighting	<a href="http://www.ti.com/energy">www.ti.com/energy</a>
Industrial	<a href="http://www.ti.com/industrial">www.ti.com/industrial</a>
Medical	<a href="http://www.ti.com/medical">www.ti.com/medical</a>
Security	<a href="http://www.ti.com/security">www.ti.com/security</a>
Space, Avionics and Defense	<a href="http://www.ti.com/space-avionics-defense">www.ti.com/space-avionics-defense</a>
Transportation and Automotive	<a href="http://www.ti.com/automotive">www.ti.com/automotive</a>
Video and Imaging	<a href="http://www.ti.com/video">www.ti.com/video</a>
Wireless	<a href="http://www.ti.com/wireless-apps">www.ti.com/wireless-apps</a>

TI E2E Community Home Page

[e2e.ti.com](http://e2e.ti.com)

Mailing Address: Texas Instruments, Post Office Box 655303, Dallas, Texas 75265  
Copyright © 2011, Texas Instruments Incorporated