

SYNCHRONOUS SEPIC / FLYBACK CONVERTER WITH 1.1A SWITCH AND INTEGRATED LDO

FEATURES

- Synchronous, Up To 90% Efficient, SEPIC Converter With 300-mA Output Current From 2.5-V Input
- Integrated 200-mA Reverse Voltage Protected LDO for DC/DC Output Voltage Post Regulation or Second Output Voltage
- 40- μ A (Typical) Quiescent Current
- Input Voltage Range: 1.8-V to 5.5-V
- Fixed and Adjustable Output Voltage Options up to 5.5-V
- Power Save Mode for Improved Efficiency at Low Output Power
- Low Battery Comparator
- Power Good Output
- Low EMI-Converter (Integrated Antiringing Switch)
- Load Disconnect During Shutdown
- Overtemperature Protection
- Available in a Small 4mm x 4mm QFN-16 or in a TSSOP-16 Package

APPLICATIONS

- All Single Cell Li, Dual or Triple Cell Battery or USB Powered Products as MP-3 Player, PDAs, and Other Portable Equipment
- Dual Input or Dual Output Mode
- High Efficient Li-Ion to 3.3-V Conversion

DESCRIPTION

The TPS6113x devices provide a complete power supply solution for products powered by either a one-cell Li-Ion or Li-Polymer, or two- to four-cell Alkaline, NiCd, or NiMH batteries. The devices can generate two regulated output voltages. It provides a simple and efficient buck-boost solution for generating 3.3 V out of an input voltage that can be both higher and lower than the output voltage. The converter provides a maximum output current of at least 300 mA with supply voltages down to 1.8 V. The implemented SEPIC converter is based on a fixed frequency, pulse-width-modulation (PWM) controller using a synchronous rectifier to obtain maximum efficiency. The maximum peak current in the SEPIC switch is limited to a value of 1600 mA.

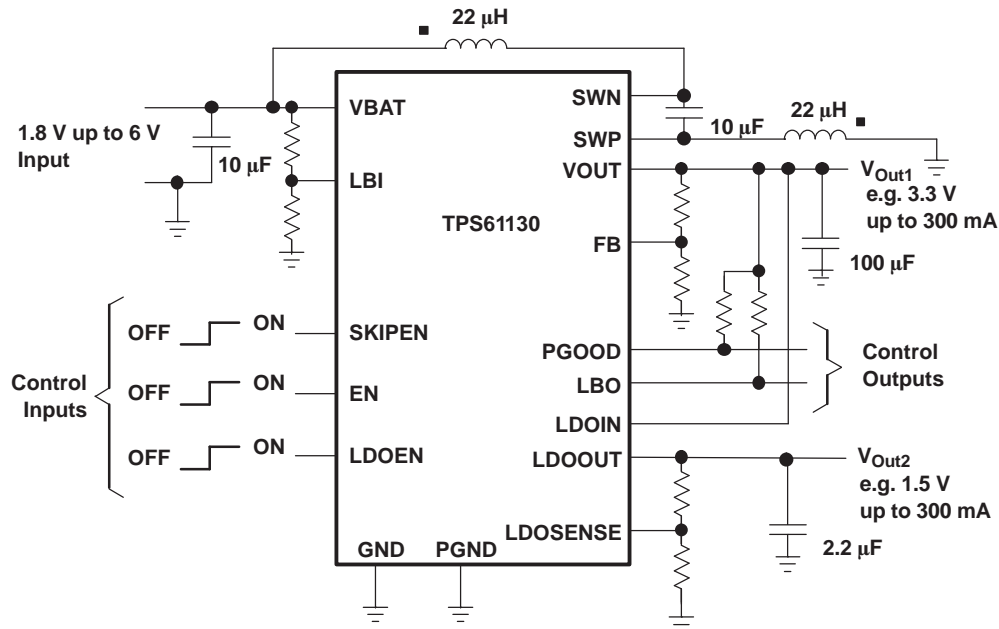

Please be aware that an important notice concerning availability, standard warranty, and use in critical applications of Texas Instruments semiconductor products and disclaimers thereto appears at the end of this data sheet.

PowerPAD is a trademark of Texas Instruments.

Description (continued)

The converter can be disabled to minimize battery drain. During shutdown, the load is completely disconnected from the battery. A low-EMI mode is implemented to reduce ringing, and in effect, lower radiated electromagnetic energy when the converter enters the discontinuous conduction mode. A power good output at the SEPIC stage provides additional control of any connected circuits like cascaded power supply stages, or microprocessors.

The built-in LDO can be used for a second output voltage derived either from the SEPIC output or directly from the battery. The output voltage of this LDO can be programmed by an external resistor divider or is fixed internally on the chip. The LDO can be enabled separately, i.e., using the power good of the SEPIC stage. The device is packaged in a 16-pin QFN package measuring 4 mm x 4 mm (RSA) or in a 16-pin TSSOP (PW) package.

AVAILABLE OUTPUT VOLTAGE OPTIONS⁽¹⁾

T _A	OUTPUT VOLTAGE DC/DC	OUTPUT VOLTAGE LDO	PACKAGE	PART NUMBER ⁽²⁾
40°C to 85°C	Adjustable	Adjustable	16-Pin TSSOP	TPS61130PW
	3.3 V	3.3 V		TPS61131PW
	3.3 V	1.5 V		TPS61132PW
	Adjustable	Adjustable	16-Pin QFN	TPS61130RSA
	3.3 V	1.5 V		TPS61132RSA

(1) Contact the factory to check availability of other fixed output voltage versions.

(2) The packages are available taped and reeled. Add R suffix to device type (e.g., TPS61130PWR or TPS61130RSAR) to order quantities of 2000 devices per reel for the TSSOP (PW) package and 3000 devices per reel for the QFN (RSA) package.

ABSOLUTE MAXIMUM RATINGS

over operating free-air temperature range (unless otherwise noted)⁽¹⁾

	TPS61130 TPS61131 TPS61132
Input voltage range on FB	–0.3 V to 3.6 V
Input voltage range on SWN	–0.3 V to 12 V
Input voltage range on SWP	–7.0 V to 7.0 V
Maximum voltage between SWP and VOUT	–12 V
Input voltage range on VOUT, LDOIN, LDOOUT, LDOEN, LDOSENSE, PGOOD, LBO, VBAT, LBI, SKIPEN, EN	–0.3 V to 7 V
Operating virtual junction temperature T _J	–40°C to 150°C
Storage temperature range T _{stg}	–65°C to 150°C

(1) Stresses beyond those listed under "absolute maximum ratings" may cause permanent damage to the device. These are stress ratings only, and functional operation of the device at these or any other conditions beyond those indicated under "recommended operating conditions" is not implied. Exposure to absolute-maximum-rated conditions for extended periods may affect device reliability.

RECOMMENDED OPERATING CONDITIONS

	MIN	NOM	MAX	UNIT
Supply voltage at VBAT	1.8		6.5	V
Operating free air temperature range, T _A	–40		85	°C
Operating virtual junction temperature, T _J	–40		125	°C

ELECTRICAL CHARACTERISTICS

over recommended free-air temperature range and over recommended input voltage range (typical at an ambient temperature range of 25°C) (unless otherwise noted)

DC/DC STAGE	PARAMETER	TEST CONDITIONS	MIN	TYP	MAX	UNIT
V_I	Input voltage range		1.8		6.5	V
V_O	Adjustable output voltage range (TPS61130)		2.5		5.5	V
V_{ref}	Reference voltage		485	500	515	mV
f	Oscillator frequency		400	500	600	kHz
I_{SW}	Switch current limit	$V_{OUT} = 3.3\text{ V}$	1100	1300	1600	mA
	Startup current limit			$0.4 \times I_{SW}$		mA
	SWN switch on resistance	$V_{OUT} = 3.3\text{ V}$		200	350	m Ω
	SWP switch on resistance	$V_{OUT} = 3.3\text{ V}$		250	500	m Ω
	Total accuracy (including line and load regulation)				± 3	%
DC/DC quiescent current	into VBAT	$I_O = 0\text{ mA}$, $V_{EN} = V_{BAT} = 1.8\text{ V}$, $V_{OUT} = 3.3\text{ V}$, $ENLDO = 0\text{ V}$		10	25	μA
	into VOUT	$I_O = 0\text{ mA}$, $V_{EN} = V_{BAT} = 1.8\text{ V}$, $V_{OUT} = 3.3\text{ V}$, $ENLDO = 0\text{ V}$		10	25	μA
	DC/DC shutdown current	$V_{EN} = 0\text{ V}$		0.2	1	μA
LDO STAGE	PARAMETER	TEST CONDITIONS	MIN	TYP	MAX	UNIT
$V_{I(LDO)}$	Input voltage range		1.8		7	V
$V_{O(LDO)}$	Adjustable output voltage range (TPS61130)		0.9		5.5	V
$I_{O(max)}$	Output current		200	320		mA
	LDO short circuit current limit				500	mA
	Minimum voltage drop	$I_O = 200\text{ mA}$			300	mV
	Total accuracy (including line and load regulation)	$I_O \geq 1\text{ mA}$			$\pm 3\%$	
	Line regulation	LDOIN change from 1.8 V to 2.6 V at 100 mA, LDOOUT = 1.5 V			0.6%	
	Load regulation	Load change from 10% to 90%, LDOIN = 3.3 V			0.6%	
	LDO quiescent current	LDOIN = 7 V, VBAT = 1.8 V, EN = VBAT		20	30	μA
	LDO shutdown current	LDOEN = 0 V, LDOIN = 7 V		0.1	1	μA
CONTROL STAGE	PARAMETER	TEST CONDITIONS	MIN	TYP	MAX	UNIT
V_{IL}	LBI voltage threshold	V_{LBI} voltage decreasing	490	500	510	mV
	LBI input hysteresis			10		mV
	LBI input current	EN = VBAT or GND		0.01	0.1	μA
	LBO output low voltage	$V_O = 3.3\text{ V}$, $I_{OI} = 100\text{ }\mu\text{A}$		0.04	0.4	V
	LBO output low current			100		μA
	LBO output leakage current	$V_{LBO} = 7\text{ V}$		0.01	0.1	μA
V_{IL}	EN, SKIPEN input low voltage				$0.2 \times V_{BAT}$	V
V_{IH}	EN, SKIPEN input high voltage		$0.8 \times V_{BAT}$			V
V_{IL}	LDOEN input low voltage				$0.2 \times V_{LDOIN}$	V
V_{IH}	LDOEN input high voltage		$0.8 \times V_{LDOIN}$			V

ELECTRICAL CHARACTERISTICS (continued)

over recommended free-air temperature range and over recommended input voltage range (typical at an ambient temperature range of 25°C) (unless otherwise noted)

CONTROL STAGE (continued)					
PARAMETER	TEST CONDITIONS	MIN	TYP	MAX	UNIT
EN, SKIPEN input current	Clamped on GND or VBAT		0.01	0.1	μA
Power-Good threshold	$V_O = 3.3\text{ V}$	$0.9 \times V_O$	$0.92 \times V_O$	$0.95 \times V_O$	V
Power-Good delay			30		μs
Power-Good output low voltage	$V_O = 3.3\text{ V}, I_{OI} = 100\mu\text{A}$		0.04	0.4	V
Power-Good output low current			100		μA
Power-Good output leakage current	$V_{PG} = 7\text{ V}$		0.01	0.1	μA
Over-Temperature protection			140		°C
Over-Temperature hysteresis			20		°C

PIN ASSIGNMENTS

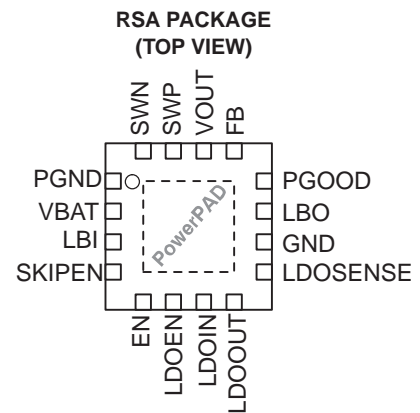
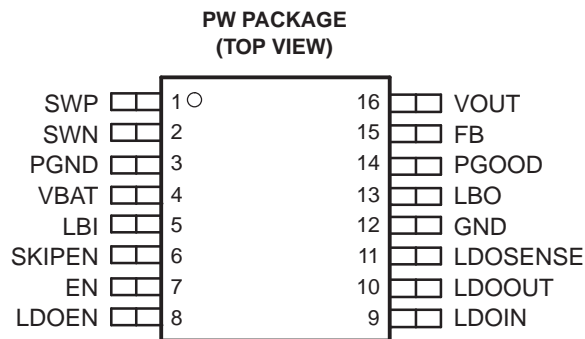

Terminal Functions

TERMINAL			I/O	DESCRIPTION
NAME	NO.			
	PW	RSA		
EN	7	5	I	DC/DC-enable input. (1/VBAT enabled, 0/GND disabled)
FB	15	13	I	DC/DC voltage feedback of adjustable versions
GND	12	10		Control/logic ground
LBI	5	3	I	Low battery comparator input (comparator enabled with EN)
LBO	13	11	O	Low battery comparator output (open drain)
LDOEN	8	6	I	LDO-enable input (1/LDOIN enabled, 0/GND disabled)
LDOOUT	10	8	O	LDO output
LDOIN	9	7	I	LDO input
LDOSENSE	11	9	I	LDO feedback for voltage adjustment, must be connected to LDOOUT at fixed output voltage versions
PGND	3	1		Power ground
PGOOD	14	12	O	DC/DC output power good (1 : good, 0 : failure) (open drain)
SKIPEN	6	4	I	Enable/disable power save mode (1/VBAT enabled, 0/GND disabled)
SWN	2	16	I	DC/DC switch input
SWP	1	15	I	DC/DC rectifying switch input
VBAT	4	2	I	Supply pin
VOUT	16	14	O	DC/DC output
PowerPAD™				Must be soldered to achieve appropriate power dissipation. Should be connected to PGND.

Functional Block Diagram

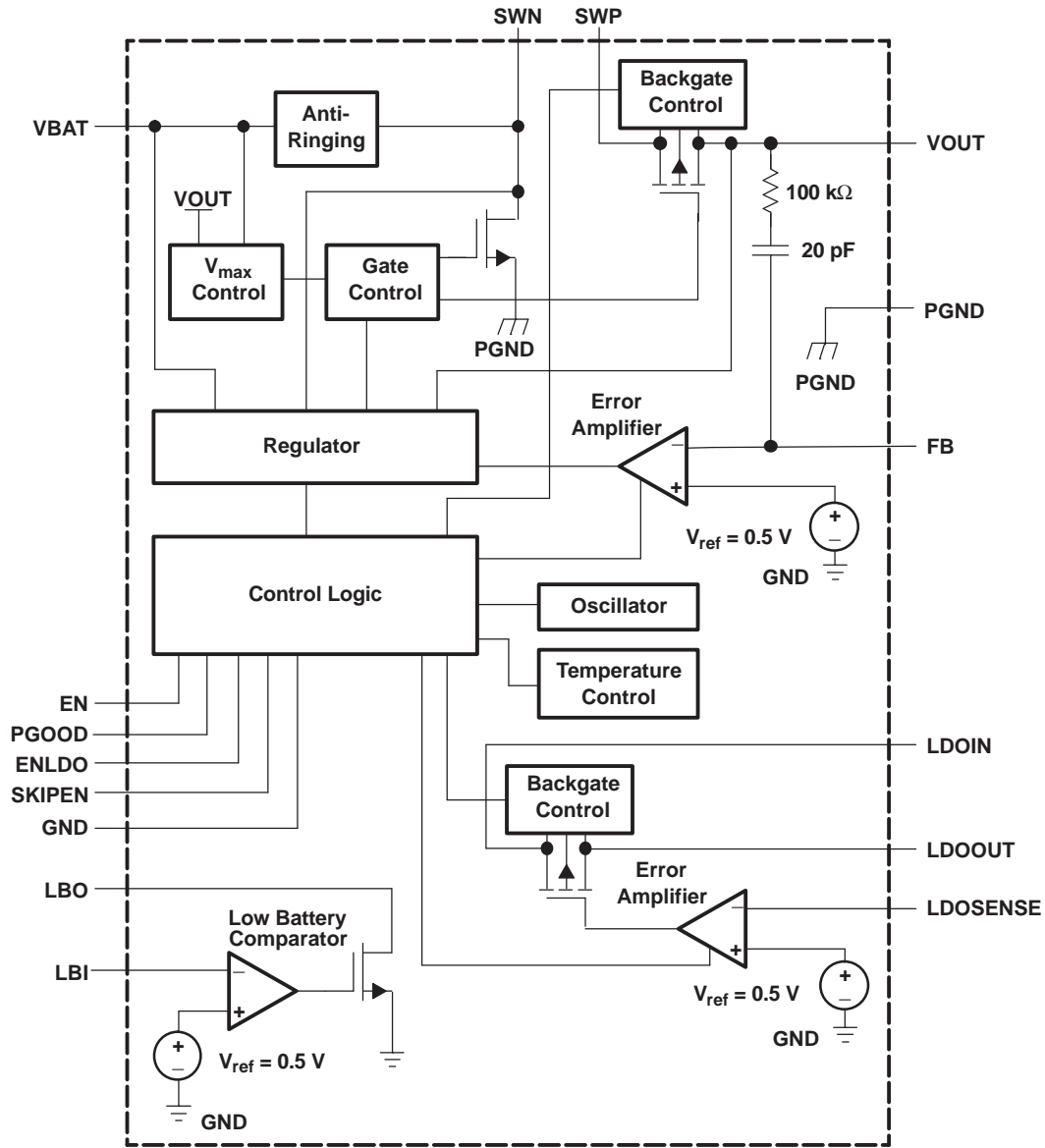

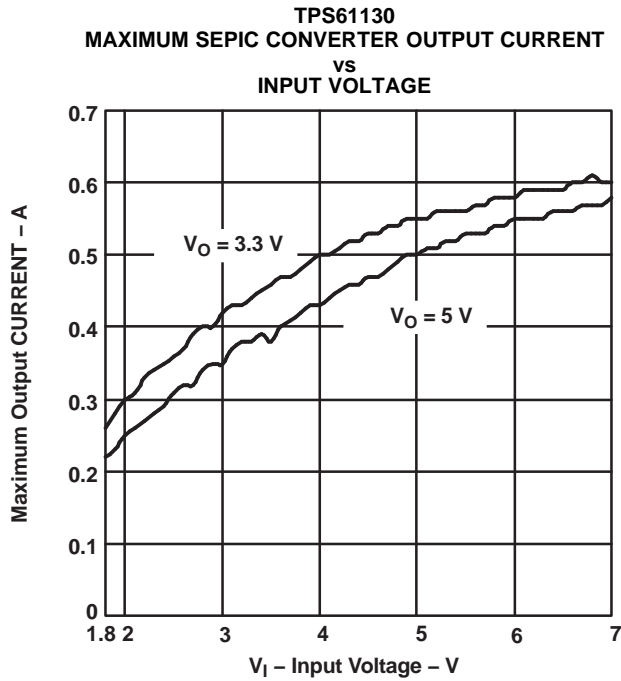

Figure 1.

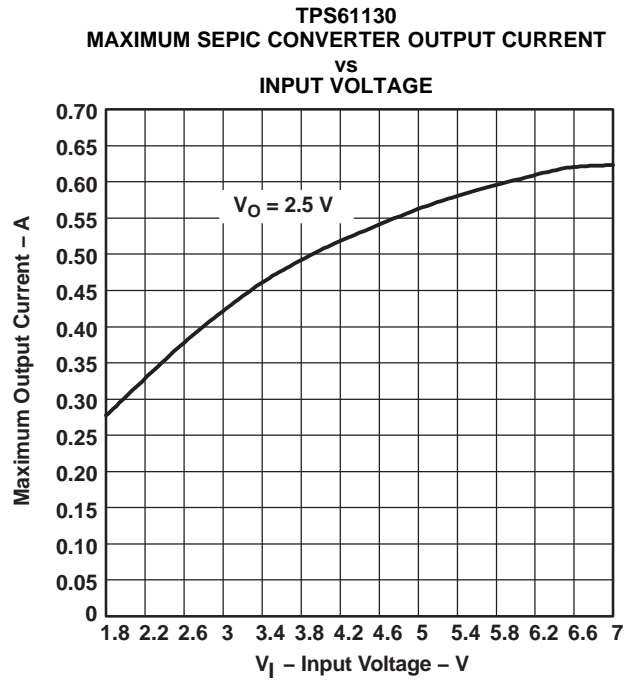

Figure 2.

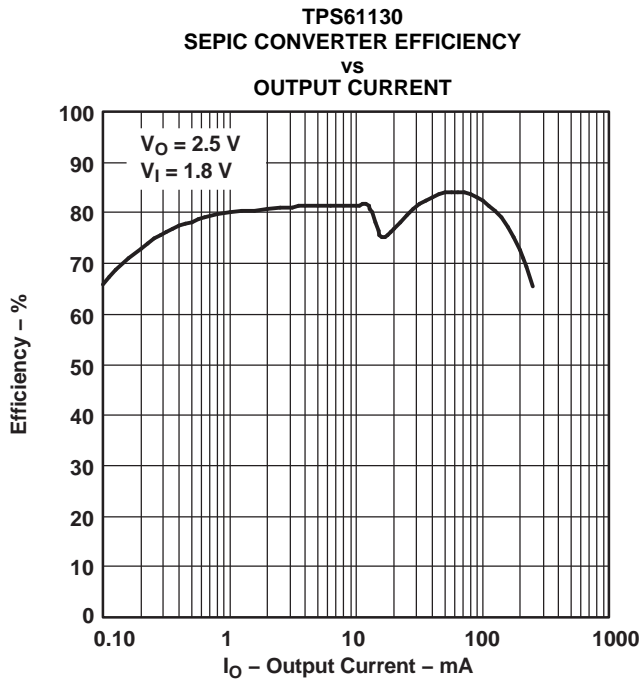

Figure 3.

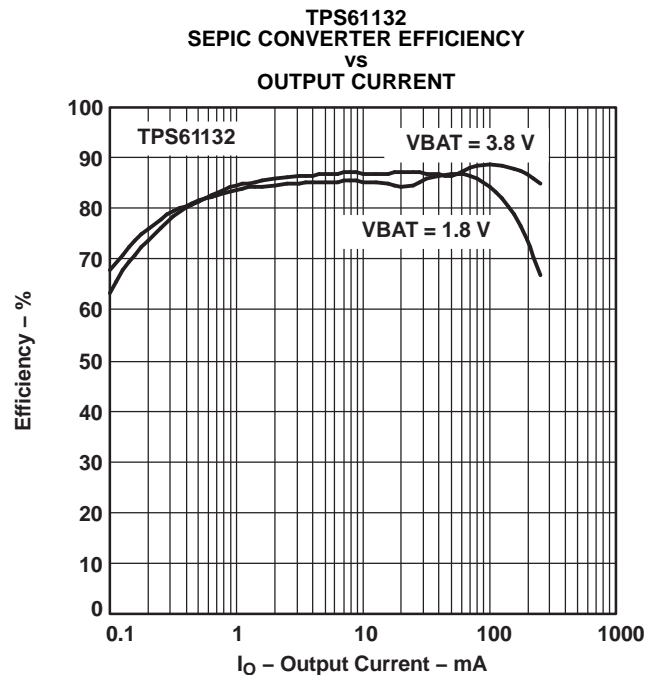
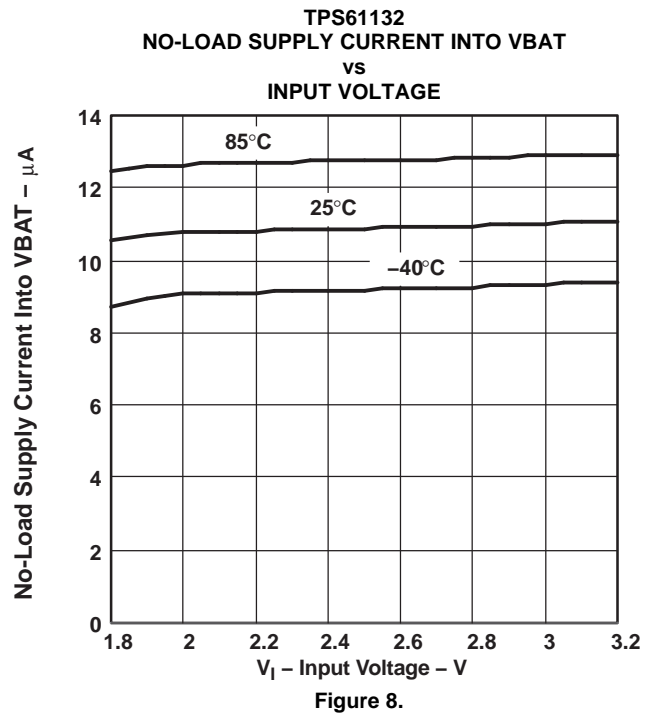
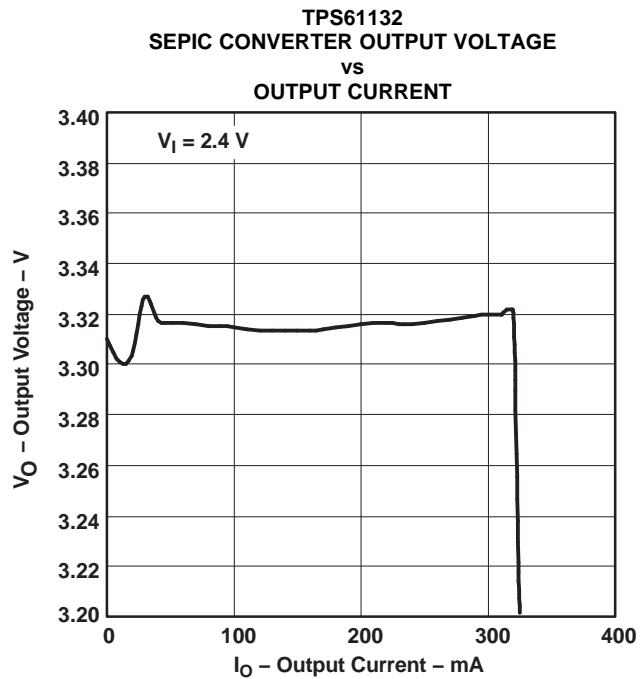
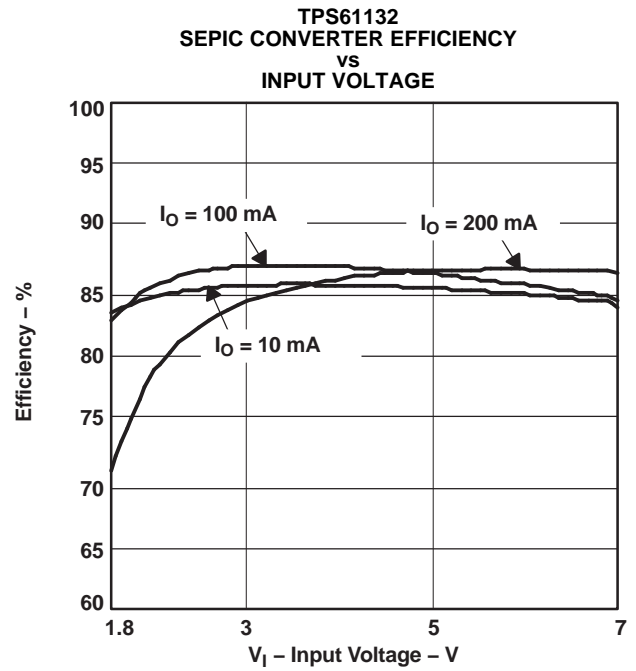
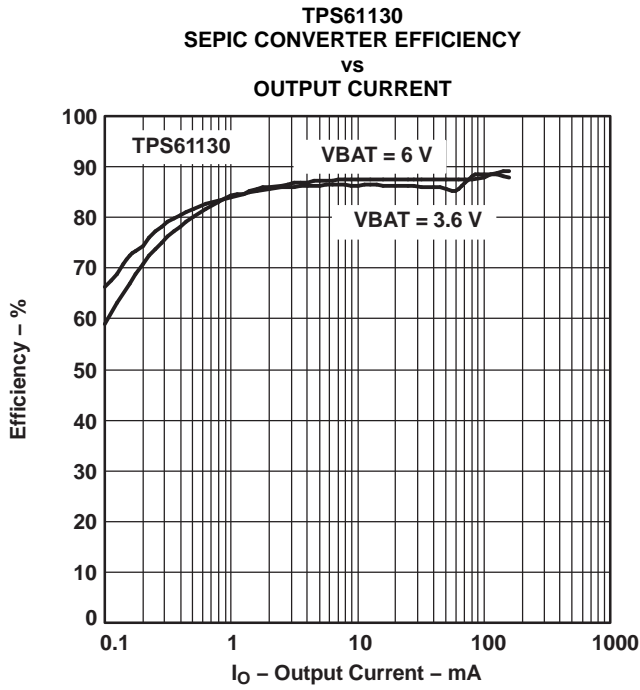

Figure 4.



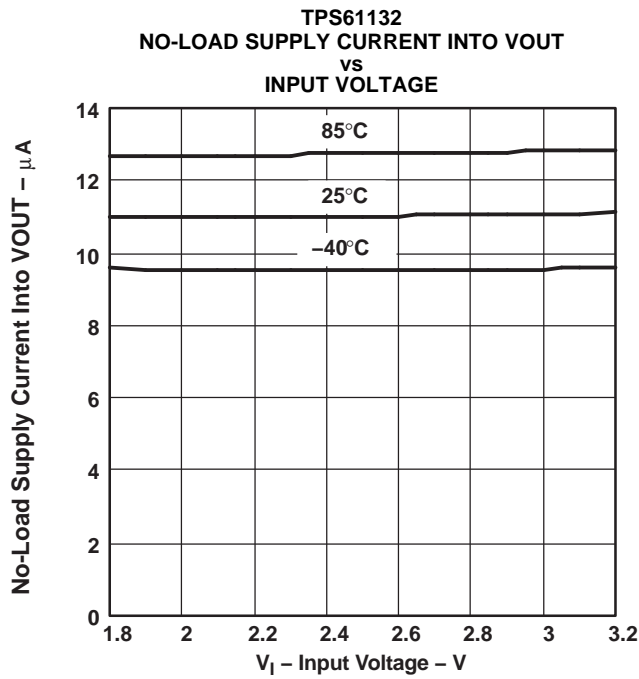

Figure 9.

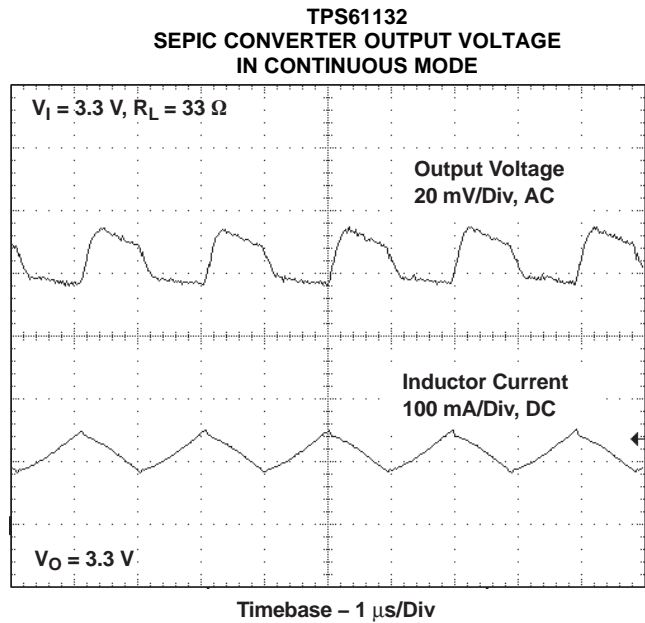

Figure 10.

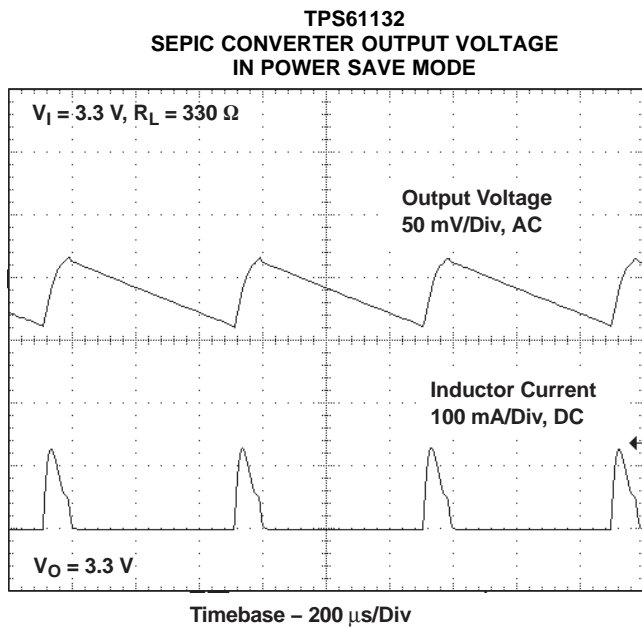

Figure 11.

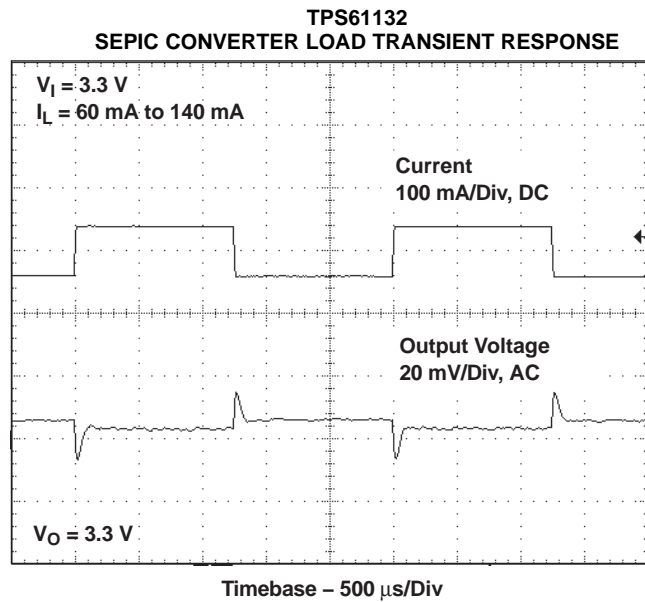
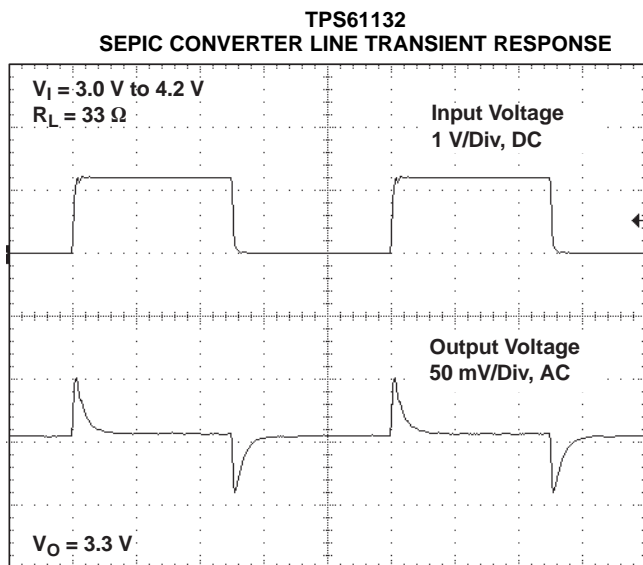
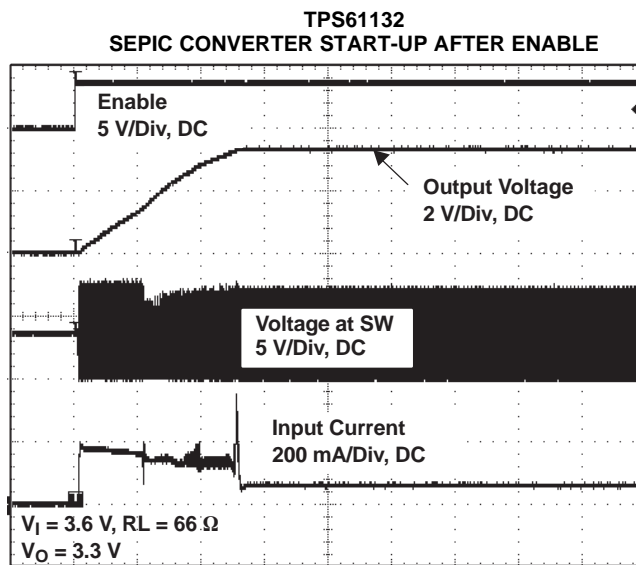

Figure 12.



Timebase – 200 $\mu\text{s}/\text{Div}$

Figure 13.



Timebase – 400 $\mu\text{s}/\text{Div}$

Figure 14.

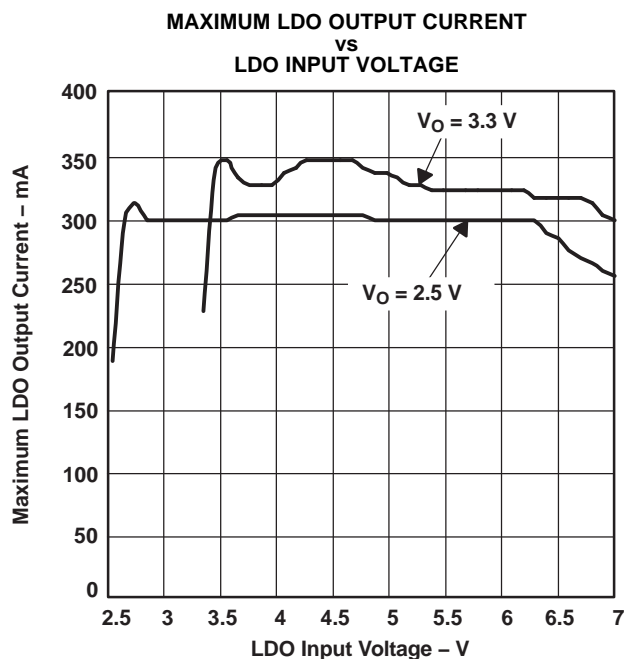

Figure 15.

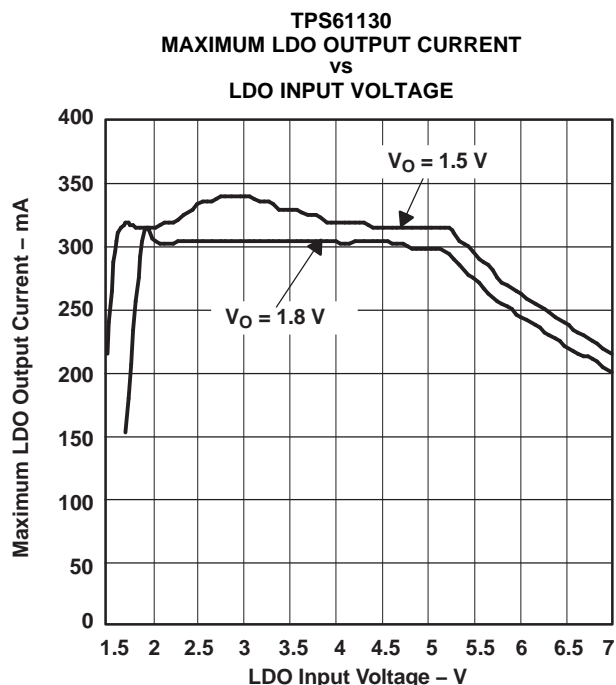

Figure 16.

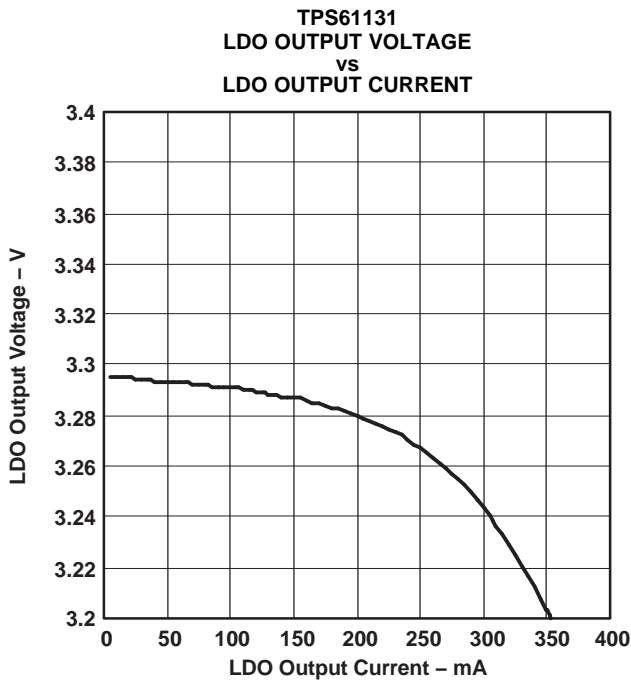

Figure 17.

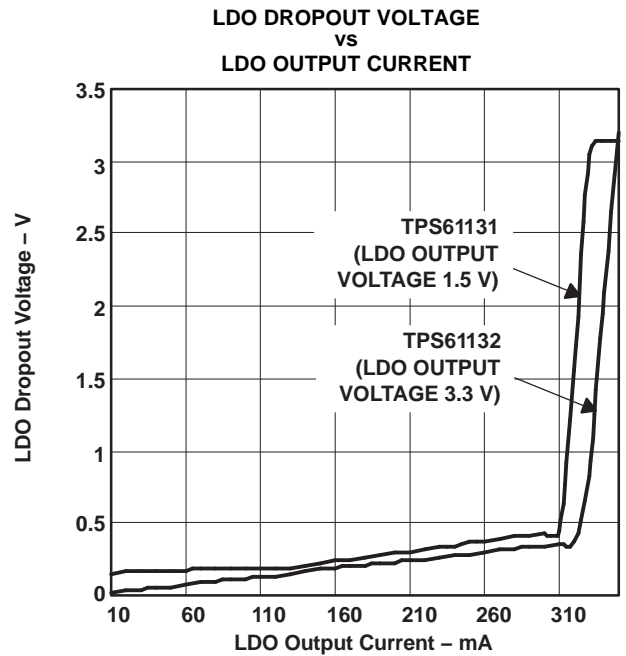

Figure 18.

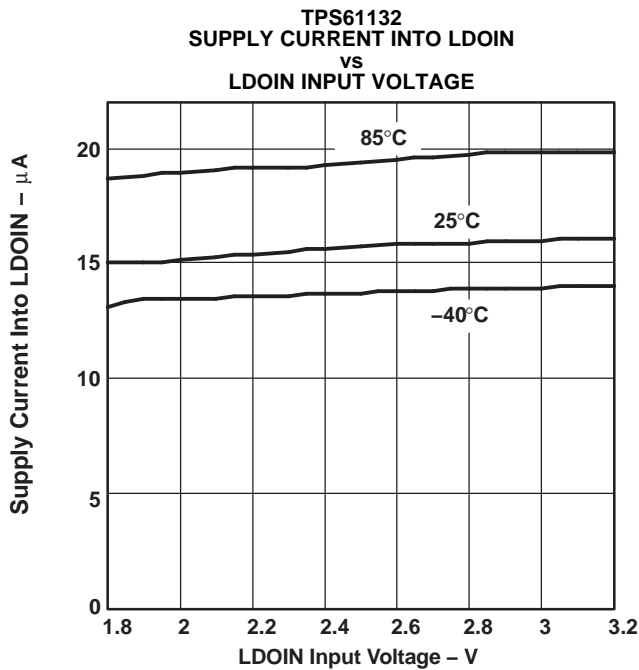

Figure 19.

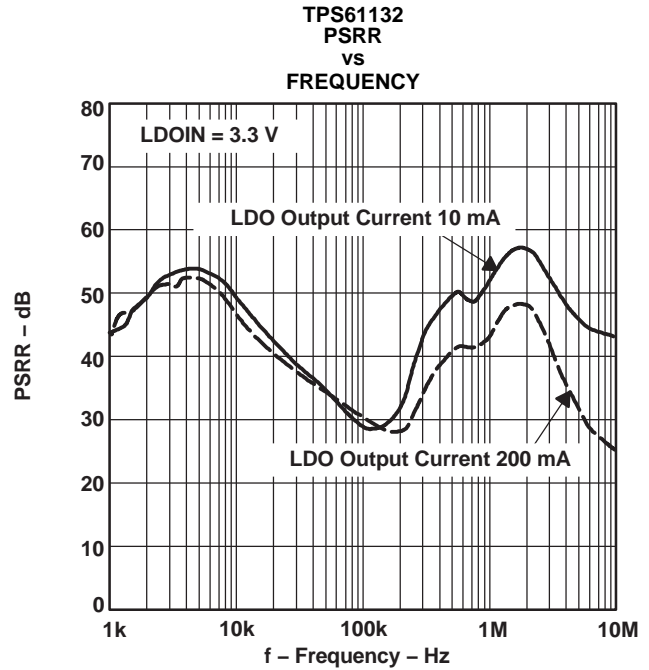
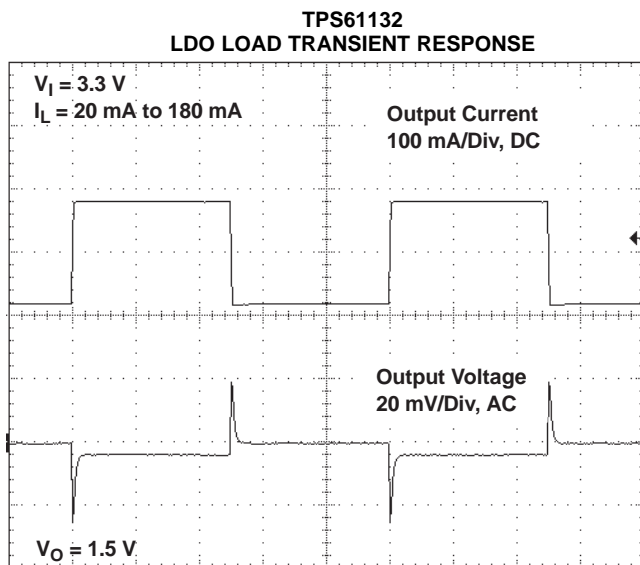
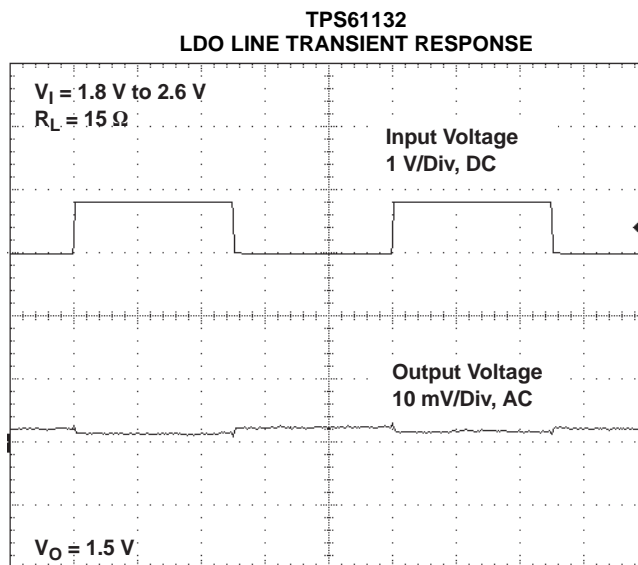

Figure 20.



Timebase – 500 $\mu\text{s/Div}$

Figure 21.



Timebase – 2 ms/Div

Figure 22.

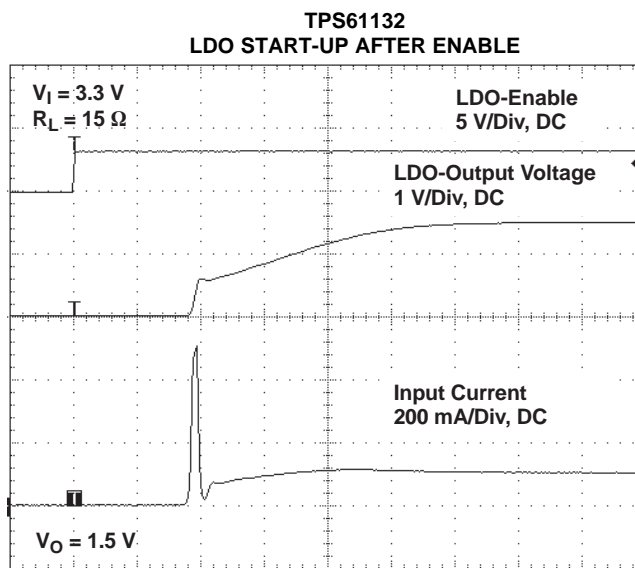

Timebase – 20 $\mu\text{s/Div}$

Figure 23.

DETAILED DESCRIPTION

Controller Circuit

The controller circuit of the device is based on a fixed frequency multiple feedforward controller topology. Input voltage, output voltage, and voltage drop on the NMOS switch are monitored and forwarded to the regulator. So changes in the operating conditions of the converter directly affect the duty cycle and must not take the indirect and slow way through the control loop and the error amplifier. The control loop, determined by the error amplifier, only has to handle small signal errors. The input for it is the feedback voltage on the FB pin or, at fixed output voltage versions, the voltage on the internal resistor divider. It is compared with the internal reference voltage to generate an accurate and stable output voltage.

The peak current of the NMOS switch is also sensed to limit the maximum current flowing through the switch and the inductor. The typical peak current limit is set to 1300 mA. An internal temperature sensor prevents the device from getting overheated in case of excessive power dissipation.

Synchronous Rectifier

The device integrates an N-channel and a P-channel MOSFET transistor to realize a synchronous rectifier. Because the commonly used discrete Schottky rectifier is replaced with a low RDS(ON) PMOS switch, the power conversion efficiency reaches 90%. To avoid ground shift due to the high currents in the NMOS switch, two separate ground pins are used. The reference for all control functions is the GND pin. The source of the NMOS switch is connected to PGND. Both grounds must be connected on the PCB at only one point close to the GND pin. Due to the nature of the SEPIC topology, there is no dc path from the battery to the output. No additional components must be added in a SEPIC or Flyback topology to make sure the battery is disconnected from the output of the converter.

Nevertheless, the backgate diode of the high-side PMOS which is forward biased in standard operation, is turned off in shutdown. This is done by a special circuit which takes the cathode of the backgate diode of the high-side PMOS and disconnects it from the source when the regulator is not enabled (EN = low).

Device Enable

The device is put into operation when EN is set high. It is put into a shutdown mode when EN is set to GND. In shutdown mode, the regulator stops switching, all internal control circuitry including the low-battery comparator is switched off, and the backgate diode of the rectifying switch is turned off (as described in the Synchronous Rectifier Section). This also means that the output voltage can drop below the input voltage during shutdown. During start-up of the converter, the duty cycle and the peak current are limited in order to avoid high peak currents drawn from the battery.

Undervoltage Lockout

An undervoltage lockout function prevents device start-up if the supply voltage on VBAT is lower than approximately 1.6 V. When in operation and the battery is being discharged, the device automatically enters the shutdown mode if the voltage on VBAT drops below approximately 1.6 V. This undervoltage lockout function is implemented in order to prevent the malfunctioning of the converter.

Softstart

When the SEPIC section is enabled, the internal startup cycle starts with switching at a duty cycle of 50%. After the output voltage has reached approximately 1.4V the device continues switching with a variable duty cycle. Until the programmed output voltage is reached, the main switch current limit is set to 40% of its nominal value to avoid high peak inrush currents at the battery during startup. Also the maximum output power during output short circuit conditions is reduced. When the programmed output voltage is reached, the regulator takes control and the switch current limit is set back to 100%.

Power Good

The PGOOD pin stays high impedance when the dc/dc converter delivers an output voltage within a defined voltage window. So it can be used to enable any connected circuitry such as cascaded converters (LDO) or microprocessor circuits.

Power Save Mode

The SKIPEN pin can be used to select different operation modes. To enable the power save mode, SKIPEN must be set high. Power save mode is used to improve efficiency at light loads. In power save mode, the converter only operates when the output voltage trips below a set threshold voltage. It ramps up the output voltage with several pulses, and goes again into power save mode once the output voltage exceeds the set threshold voltage. The power save mode can be disabled by setting the SKIPEN to GND.

Low Battery Detector Circuit—LBI/LBO

The low-battery detector circuit is typically used to supervise the battery voltage and to generate an error flag when the battery voltage drops below a user-set threshold voltage. The function is active only when the device is enabled. When the device is disabled, the LBO pin is high-impedance. The switching threshold is 500 mV at LBI. During normal operation, LBO stays at high impedance when the voltage, applied at LBI, is above the threshold. It is active low when the voltage at LBI goes below 500 mV.

The battery voltage, at which the detection circuit switches, can be programmed with a resistive divider connected to the LBI pin. The resistive divider scales down the battery voltage to a voltage level of 500 mV, which is then compared to the LBI threshold voltage. The LBI pin has a built-in hysteresis of 10 mV. See the application section for more details about the programming of the LBI threshold. If the low-battery detection circuit is not used, the LBI pin should be connected to GND (or to VBAT) and the LBO pin can be left unconnected. Do not let the LBI pin float.

Low-EMI Switch

The device integrates a circuit that removes the ringing that typically appears on the SW node when the converter enters discontinuous current mode. In this case, the current through the inductor ramps to zero and the rectifying PMOS switch is turned off to prevent a reverse current flowing from the output capacitors back to the battery. Due to the remaining energy that is stored in parasitic components of the semiconductor and the inductor, a ringing on the SW pin is induced. The integrated antiringing switch clamps this voltage to VBAT and therefore dampens ringing.

LDO

The built-in LDO can be used to generate a second output voltage derived from the dc/dc converter output, from the battery, or from another power source like an ac adapter or a USB power rail. The LDO is capable of being back biased. This allows the user just to connect the outputs of dc/dc converter and LDO. So the device is able to supply the load via dc/dc converter when the energy comes from the battery and efficiency is most important and from another external power source via the LDO when lower efficiency is not critical. The LDO must be disabled if the LDOIN voltage drops below LDOOUT to block reverse current flowing. The status of the dc/dc stage (enabled or disabled) does not matter.

LDO Enable

The LDO can be separately enabled and disabled by using the LDOEN pin in the same way as the EN pin at the dc/dc converter stage described above. This is completely independent of the status of the EN pin. The voltage levels of the logic signals which need to be applied at LDOEN are related to LDOIN.

APPLICATION INFORMATION

DESIGN PROCEDURE

The TPS6113x dc/dc converters are intended for systems powered by a dual up to 4 cell NiCd or NiMH battery with a typical terminal voltage between 1.8 V and 6.5 V. They can also be used in systems powered by one-cell Li-Ion with a typical stack voltage between 2.5 V and 4.2 V. Additionally, two up to four primary alkaline battery cells can be the power source in systems where the TPS6113x is used.

Programming the Output Voltage

DC/DC Converter

The output voltage of the TPS61130 dc/dc converter section can be adjusted with an external resistor divider. The typical value of the voltage on the FB pin is 500 mV. The maximum recommended value for the output voltage is 5.5 V. The current through the resistive divider should be about 100 times greater than the current into the FB pin. The typical current into the FB pin is 0.01 μ A and the voltage across R6 is typically 500 mV. Based on those two values, the recommended value for R6 should be lower than 500 k Ω , in order to set the divider current at 1 μ A or higher. Because of internal compensation circuitry the value for this resistor should be in the range of 200 k Ω . From that, the value of resistor R3, depending on the needed output voltage (V_O), can be calculated using Equation 1:

$$R3 = R6 \times \left(\frac{V_O}{V_{FB}} - 1 \right) = 180 \text{ k}\Omega \times \left(\frac{V_O}{500 \text{ mV}} - 1 \right) \quad (1)$$

If as an example, an output voltage of 3.3 V is needed, a 1-M Ω resistor should be chosen for R3. If for any reason the value for R6 is chosen significantly lower than 200 k Ω additional capacitance in parallel to R3 is recommended. The required capacitance value can be easily calculated using Equation 2.

$$C_{\text{par}R3} = 20 \text{ pF} \times \left(\frac{200 \text{ k}\Omega}{R6} - 1 \right) \quad (2)$$

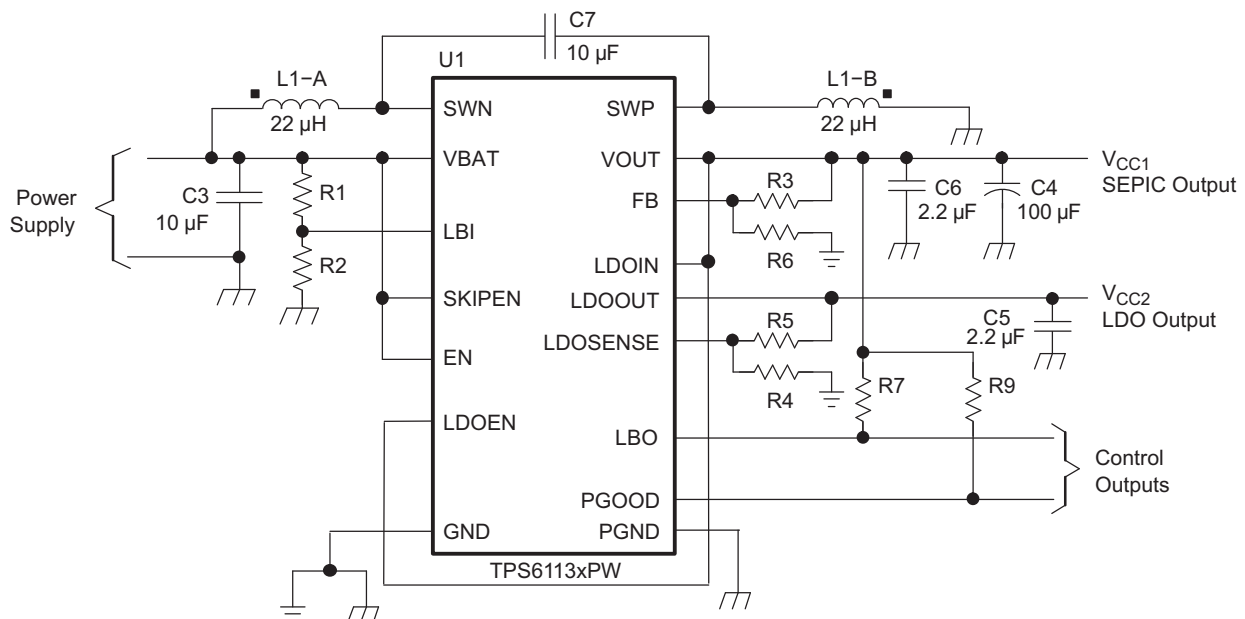

Figure 24. Typical Application Circuit for Adjustable Output Voltage Option

LDO

Programming the output voltage of the LDO follows almost the same rules as at the dc/dc converter section. The maximum recommended output voltage of the LDO is 5.5 V. Since reference and internal feedback circuitry are similar, as they are at the dc/dc converter section, R4 also should be in the 200-kΩ range. The calculation of the value of R5 can be done using the following [Equation 3](#):

$$R5 = R4 \times \left(\frac{V_O}{V_{FB}} - 1 \right) = 180 \text{ k}\Omega \times \left(\frac{V_O}{500 \text{ mV}} - 1 \right) \quad (3)$$

If as an example, an output voltage of 1.5 V is needed, a 360 kΩ-resistor should be chosen for R5.

Programming the LBI/LBO Threshold Voltage

The current through the resistive divider should be about 100 times greater than the current into the LBI pin. The typical current into the LBI pin is 0.01 μA, and the voltage across R2 is equal to the LBI voltage threshold that is generated on-chip, which has a value of 500 mV. The recommended value for R2 is therefore in the range of 500 kΩ. From that, the value of resistor R1, depending on the desired minimum battery voltage V_{BAT} , can be calculated using [Equation 4](#).

$$R1 = R2 \times \left(\frac{V_{BAT}}{V_{LBI\text{-threshold}}} - 1 \right) = 390 \text{ k}\Omega \times \left(\frac{V_{BAT}}{500 \text{ mV}} - 1 \right) \quad (4)$$

The output of the low battery supervisor is a simple open-drain output that goes active low if the dedicated battery voltage drops below the programmed threshold voltage on LBI. The output requires a pullup resistor with a recommended value of 1 MΩ. The maximum voltage which is used to pull up the LBO outputs should not exceed the output voltage of the dc/dc converter. If not used, the LBO pin can be left floating or tied to GND.

Inductor Selection

A SEPIC converter normally requires three main passive components for storing energy during the conversion. Two inductors, a flying capacitor, and a storage capacitor at the output are required. To select the two inductors, it is recommended to keep the possible peak inductor current below the current limit threshold of the power switch in the chosen configuration. For example, the typical current limit threshold of the TPS6113x's switch is 1300 mA at an output voltage of 3.3 V. The highest peak current through the switch is the sum of the two inductor currents and depends on the output load, the input (V_{BAT}), and the output voltage (V_{OUT}). Estimation of the maximum average inductor current of each inductor can be done using [Equation 5](#):

$$I_{L1-A} = I_{L1-B} = I_{OUT} \times \frac{V_{OUT}}{V_{BAT} \times 0.8} \quad (5)$$

For example, for an output current of 300 mA at 3.3 V, at least 680 mA of average current flows through each of the the inductors at a minimum input voltage of 1.8 V.

The second parameter for choosing the inductor is the desired current ripple in the inductor. Normally, it is advisable to work with a ripple of around ±20% of the average inductor current. A smaller ripple reduces the magnetic hysteresis losses in the inductor, as well as output voltage ripple and EMI. But in the same way, regulation time at load changes rises. In addition, a larger inductor increases the total system costs. With those parameters, it is possible to calculate the value for the inductor by using [Equation 6](#):

$$L1 - A = L1 - B = \frac{V_{BAT} \times V_{OUT}}{\Delta I_L \times f \times (V_{OUT} + V_{BAT})} \quad (6)$$

Parameter f is the switching frequency and ΔI_L is the ripple current in the inductor, i.e., 40% ΔI_L . In this example, the desired inductance is in the range of 20 μH. With this calculated value and the calculated currents, it is possible to choose a suitable inductor. In typical applications a 22 μH inductance is recommended. The device

has been optimized to operate with inductance values between 10 μ H and 47 μ H. Nevertheless operation with higher inductance values may be possible in some applications. Detailed stability analysis is recommended. Care has to be taken that load transients and losses in the circuit can lead to higher currents as estimated in [Equation 6](#). Also, the losses in the inductor caused by magnetic hysteresis losses and copper losses are a major parameter for total circuit efficiency.

The following inductor series from different suppliers have been used with the TPS6113X converters:

List of Inductors

VENDOR	RECOMMENDED INDUCTOR SERIES	COUPLED INDUCTOR SERIES
Coilcraft	LPS4012	LPD4012
	LPS3015	
Cooper Electronics Technologies	DR73	DRQ73
	DR74	DRQ74
EPCOS	B82462G	
Sumida	CDRH5D18	
Würth Elektronik	7447789__	744878220
	7447779__	744877220

Capacitor Selection

Input Capacitor

At least a 10- μ F input capacitor is recommended to improve transient behavior of the regulator and EMI behavior of the total power supply circuit. A ceramic capacitor or a tantalum capacitor with a 100-nF ceramic capacitor in parallel, placed close to the IC, is recommended.

Flying Capacitor DC/DC Converter

In the normal operating mode, the *flying* capacitor (C7) must be large enough so that the voltage across the capacitor is small. This means the resonance frequency formed by the *flying* capacitor and the inductors must be at least ten times lower than the switching frequency (see [Equation 7](#)).

$$C_{\min} = \frac{100}{4\pi^2 f^2 L} \tag{7}$$

Where L is the inductance of L1-A or L1-B.

To optimize efficiency, capacitors with very low ESR such as ceramic capacitors are recommended. The voltage rating of the *flying* capacitor must be higher than the input voltage V_{BAT} .

Output Capacitor DC/DC Converter

The major parameter necessary to define the output capacitor is the maximum allowed output voltage ripple of the converter. This ripple is determined by two parameters of the capacitor, the capacitance and the ESR. It is possible to calculate the minimum capacitance needed for the defined ripple, supposing that the ESR is zero, by using [Equation 8](#):

$$C_{\min} = \frac{I_{OUT} \times V_{OUT}}{f \times \Delta V \times (V_{OUT} + V_{BAT})} \tag{8}$$

Parameter *f* is the switching frequency and ΔV is the maximum allowed ripple.

With a chosen ripple voltage of 15 mV, a minimum capacitance of 26 μ F is needed. The total ripple is larger due to the ESR of the output capacitor. This additional component of the ripple can be calculated using [Equation 9](#):

$$\Delta V_{ESR} = I_{OUT} \times R_{ESR} \tag{9}$$

An additional ripple of 24 mV is the result of using a tantalum capacitor with a low ESR of 80 m Ω . The total ripple is the sum of the ripple caused by the capacitance and the ripple caused by the ESR of the capacitor. In this example, the total ripple is 39 mV. Additional ripple is caused by load transients. This means that the output

capacitance needs to be larger than calculated above to meet the total ripple requirements. The output capacitor has to completely supply the load during the charging phase of the inductor. A reasonable value of the output capacitance depends on the speed of the load transients and the load current during the load change. With the calculated minimum value of 26 μF and load transient considerations the recommended output capacitance value is in a 100 μF range. For economical reasons this usually is a tantalum capacitor. Because of this the control loop has been optimized for using output capacitors with an ESR of above 30 m Ω . The minimum value for the output capacitor is 22 μF .

Small Signal Stability

When using output capacitors with lower ESR, like ceramics, it is recommended to use the adjustable voltage version. The missing ESR can be easily compensated there in the feedback divider. Typically a capacitor in the range of 10 pF in parallel with R3 helps to obtain small signal stability, with the lowest ESR output capacitors. For more detailed analysis the small signal transfer function of the error amplifier and regulator, which is given in [Equation 10](#), can be used.

$$A_{\text{REG}} = \frac{d}{V_{\text{FB}}} = \frac{10 \times (R3 + R6)}{R6 \times (1 + i \times \omega \times 1.6 \mu\text{s})} \quad (10)$$

Output Capacitor LDO

To ensure stable output regulation, it is required to use an output capacitor at the LDO output. Ceramic capacitors in the range from 1 μF up to 4.7 μF are recommended. At 4.7 μF and above it is recommended to use standard ESR tantalum. There is no maximum capacitance value.

Layout Considerations

For all switching power supplies, the layout is an important step in the design, especially at high peak currents and high switching frequencies. If the layout is not carefully done, the regulator could show stability problems as well as EMI problems. Therefore, use wide and short traces for the main current path and for the power ground tracks. The input capacitor, output capacitor, and the inductor should be placed as close as possible to the IC. Use a common ground node for power ground and a different one for control ground to minimize the effects of ground noise. Connect these ground nodes at any place close to one of the ground pins of the IC.

The feedback divider should be placed as close as possible to the control ground pin of the IC. To lay out the control ground, it is recommended to use short traces as well, separated from the power ground traces. This avoids ground shift problems, which can occur due to superimposition of power ground current and control ground current.

APPLICATION EXAMPLES

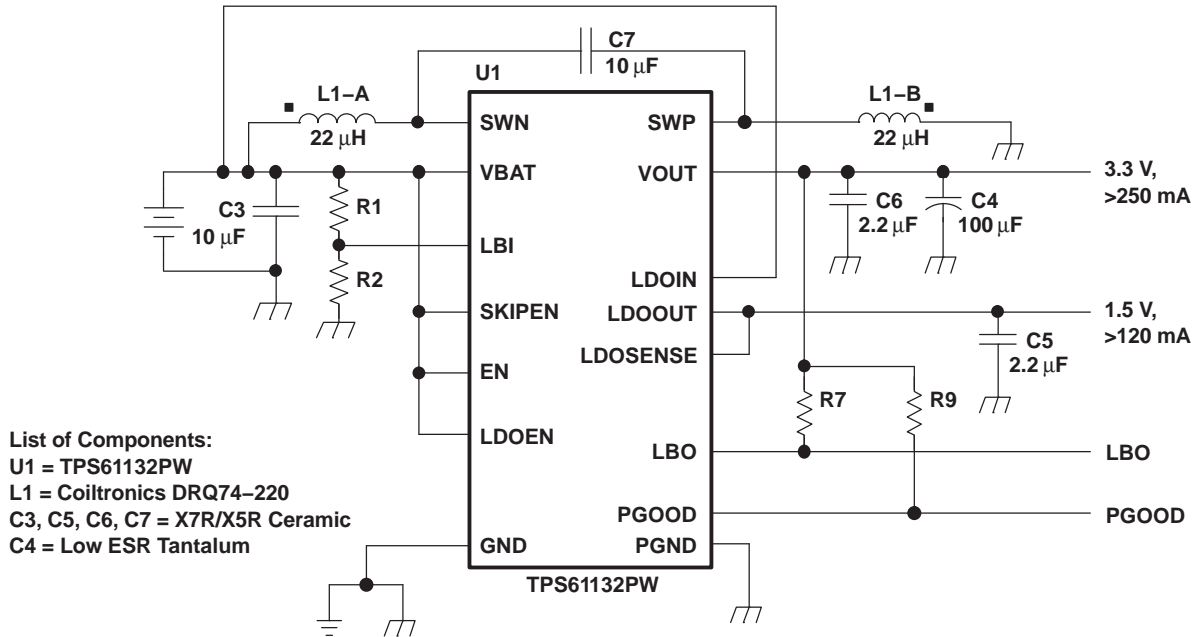

Figure 25. Solution for Maximum Output Power

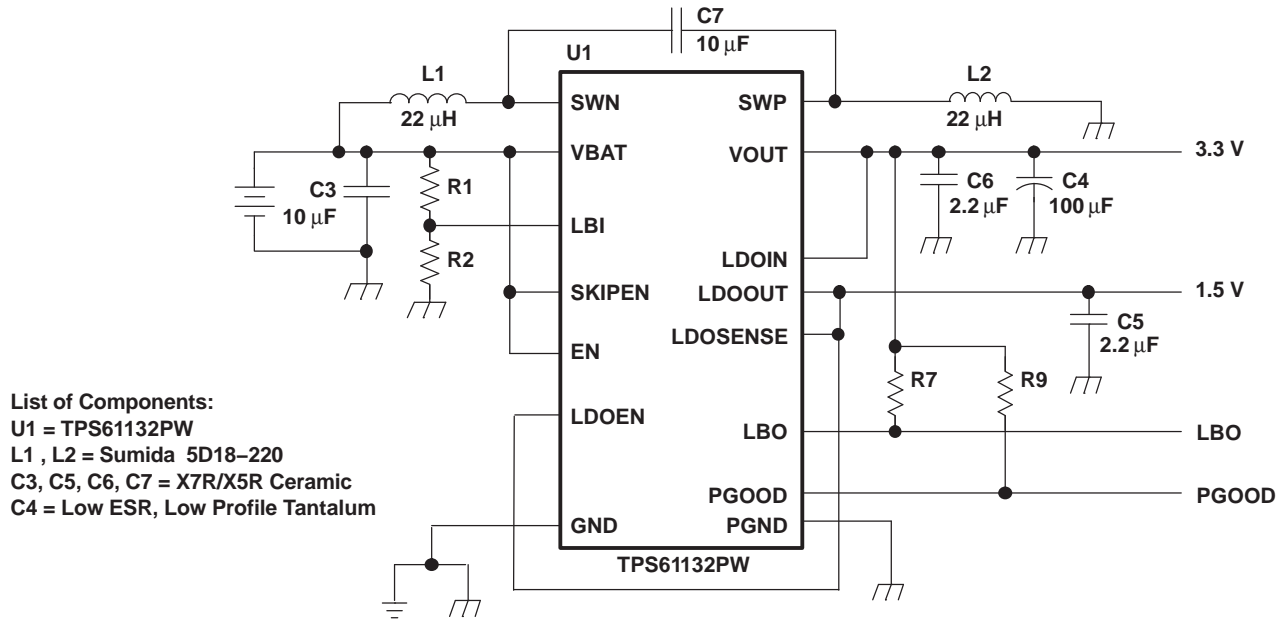

Figure 26. Low Profile Solution, Maximum Height 1,8 mm

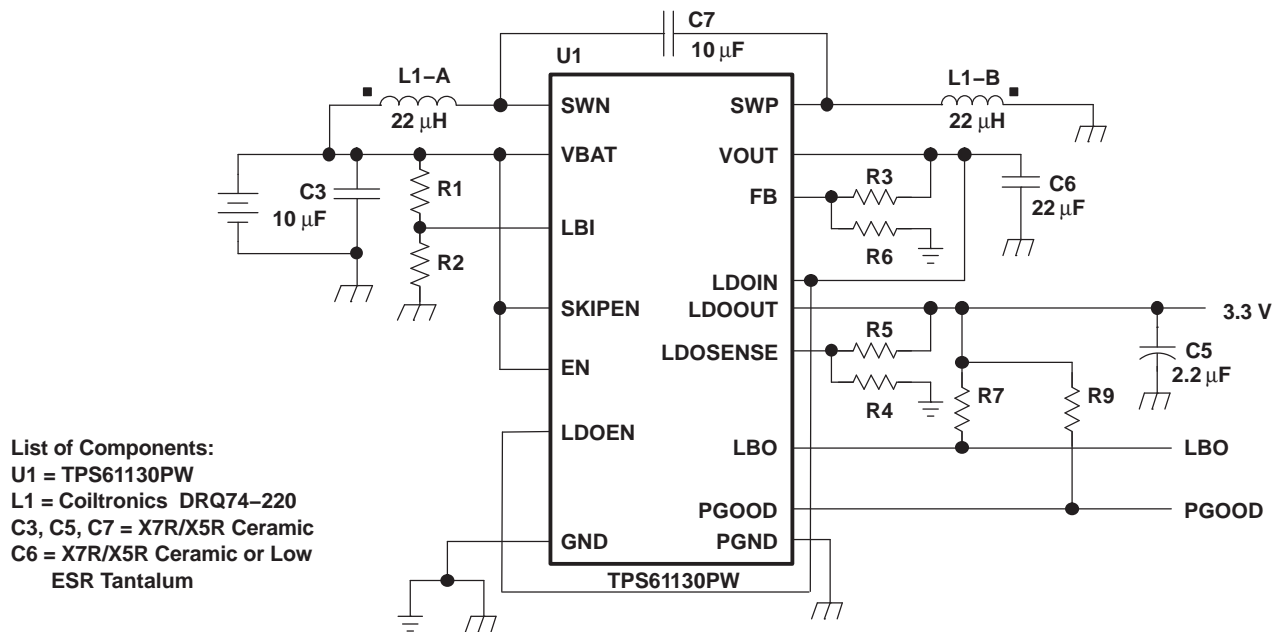

Figure 27. Single Output Using LDO as Filter

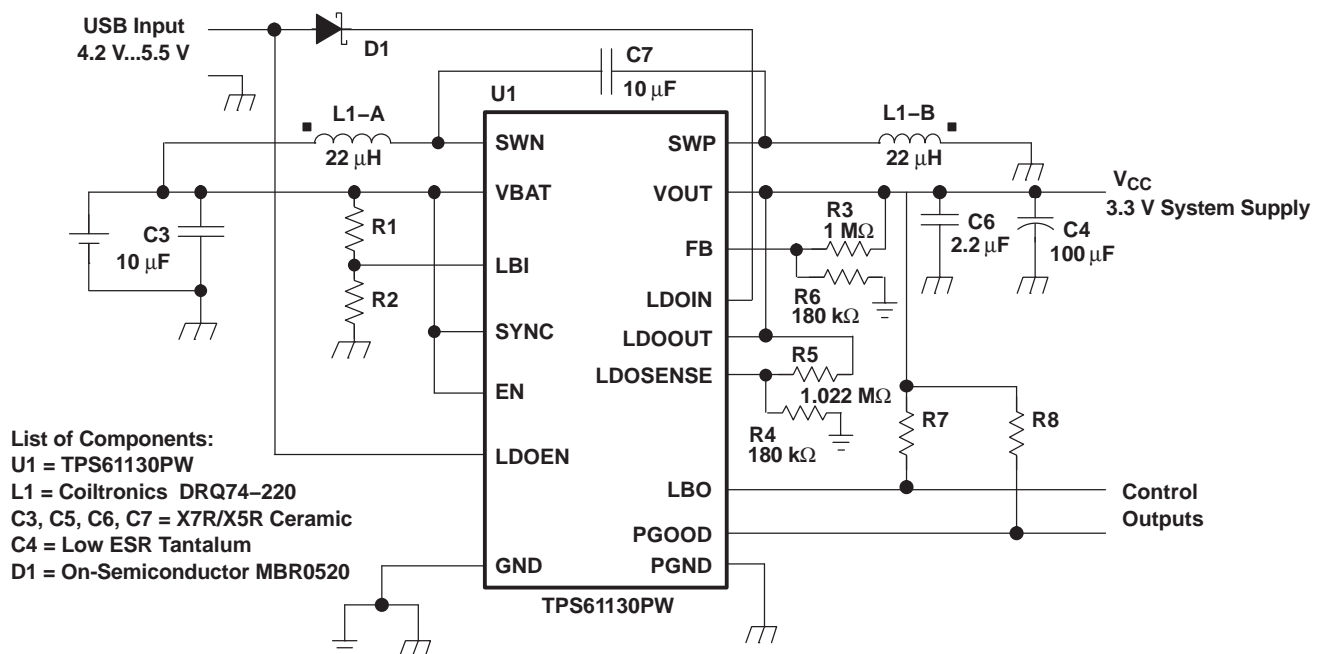

Figure 28. Dual Input Power Supply Solution

THERMAL INFORMATION

Implementation of integrated circuits in low-profile and fine-pitch surface-mount packages typically requires special attention to power dissipation. Many system-dependent issues such as thermal coupling, airflow, added heat sinks and convection surfaces, and the presence of other heat-generating components affect the power-dissipation limits of a given component.

Three basic approaches for enhancing thermal performance are listed below.

- Improving the power dissipation capability of the PCB design.
- Improving the thermal coupling of the component to the PCB.
- Introducing airflow in the system.

The maximum recommended junction temperature (T_J) of the TPS6113x devices is 150°C. The thermal resistance of the 16-pin TSSOP package (PW) is $R_{\theta JA} = 155\text{ }^\circ\text{C/W}$. The 16-pin QFN PowerPAD package (RSA) has a thermal resistance of $R_{\theta JA} = 38.1\text{ }^\circ\text{C/W}$, if the PowerPAD is soldered and the board layout is optimized. Specified regulator operation is assured to a maximum ambient temperature T_A of 85°C. Therefore, the maximum power dissipation is about 420 mW for the TSSOP (PW) package and 1700 mW for the QFN (RSA) package. More power can be dissipated if the maximum ambient temperature of the application is lower (see [Equation 11](#)).

$$P_{D(\text{MAX})} = \frac{T_{J(\text{MAX})} - T_A}{R_{\theta JA}} = \frac{150^\circ\text{C} - 85^\circ\text{C}}{155^\circ\text{C/W}} = 420\text{ mW} \quad (11)$$

If designing for a lower junction temperature of 125°C, which is recommended, maximum heat dissipation is lower. Using the above [Equation 11](#) results in 1050 mW power dissipation for the RSA package and 260 mW for the PW package.

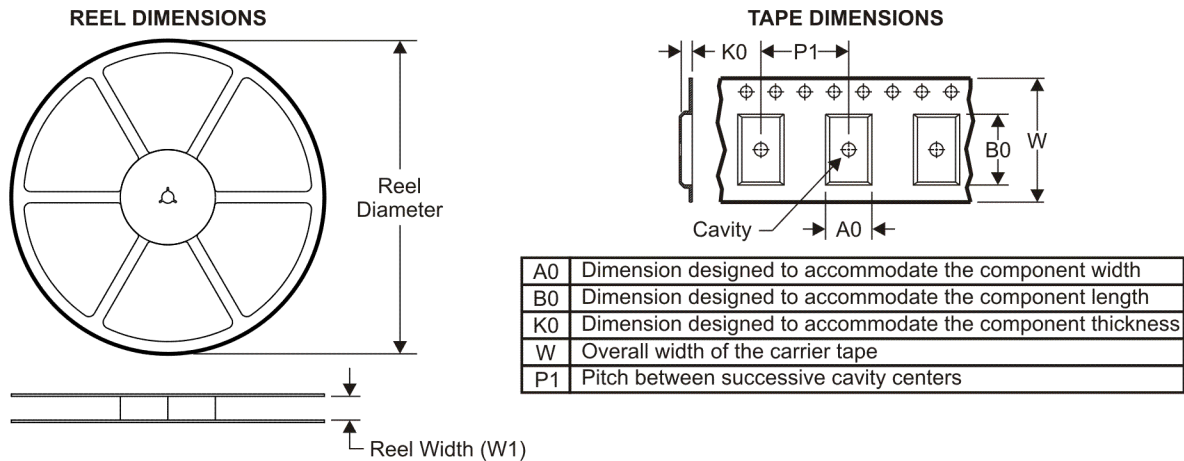
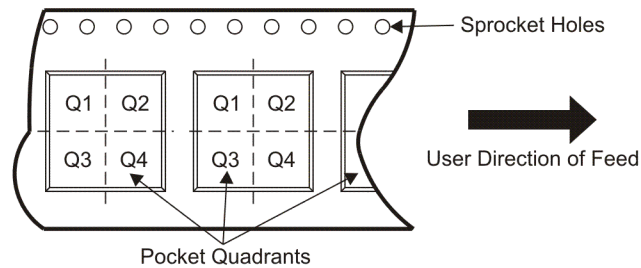
TAPE AND REEL INFORMATION

QUADRANT ASSIGNMENTS FOR PIN 1 ORIENTATION IN TAPE

*All dimensions are nominal

Device	Package Type	Package Drawing	Pins	SPQ	Reel Diameter (mm)	Reel Width W1 (mm)	A0 (mm)	B0 (mm)	K0 (mm)	P1 (mm)	W (mm)	Pin1 Quadrant
TPS61130PWR	TSSOP	PW	16	2000	330.0	12.4	6.9	5.6	1.6	8.0	12.0	Q1
TPS61130RSAR	QFN	RSA	16	3000	330.0	12.4	4.3	4.3	1.5	8.0	12.0	Q2
TPS61131PWR	TSSOP	PW	16	2000	330.0	12.4	6.9	5.6	1.6	8.0	12.0	Q1
TPS61132PWR	TSSOP	PW	16	2000	330.0	12.4	6.9	5.6	1.6	8.0	12.0	Q1
TPS61132RSAR	QFN	RSA	16	3000	330.0	12.4	4.3	4.3	1.5	8.0	12.0	Q2

TAPE AND REEL BOX DIMENSIONS

*All dimensions are nominal

Device	Package Type	Package Drawing	Pins	SPQ	Length (mm)	Width (mm)	Height (mm)
TPS61130PWR	TSSOP	PW	16	2000	346.0	346.0	29.0
TPS61130RSAR	QFN	RSA	16	3000	340.5	333.0	20.6
TPS61131PWR	TSSOP	PW	16	2000	346.0	346.0	29.0
TPS61132PWR	TSSOP	PW	16	2000	346.0	346.0	29.0
TPS61132RSAR	QFN	RSA	16	3000	340.5	333.0	20.6

PW (R-PDSO-G16)

PLASTIC SMALL OUTLINE

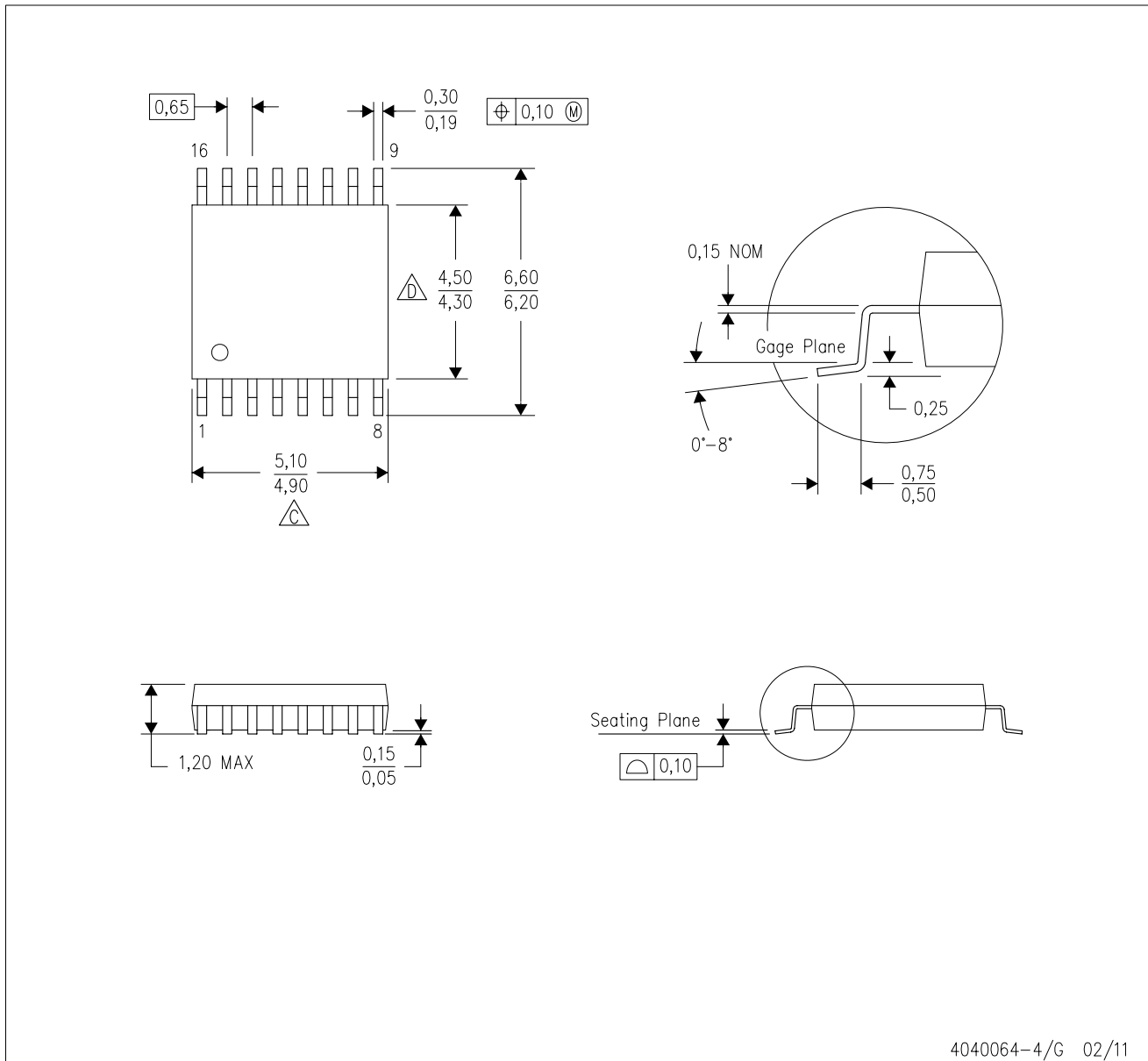

4040064-4/G 02/11

- NOTES:
- A. All linear dimensions are in millimeters. Dimensioning and tolerancing per ASME Y14.5M-1994.
 - B. This drawing is subject to change without notice.
 - C. Body length does not include mold flash, protrusions, or gate burrs. Mold flash, protrusions, or gate burrs shall not exceed 0,15 each side.
 - D. Body width does not include interlead flash. Interlead flash shall not exceed 0,25 each side.
 - E. Falls within JEDEC MO-153

PW (R-PDSO-G16)

PLASTIC SMALL OUTLINE

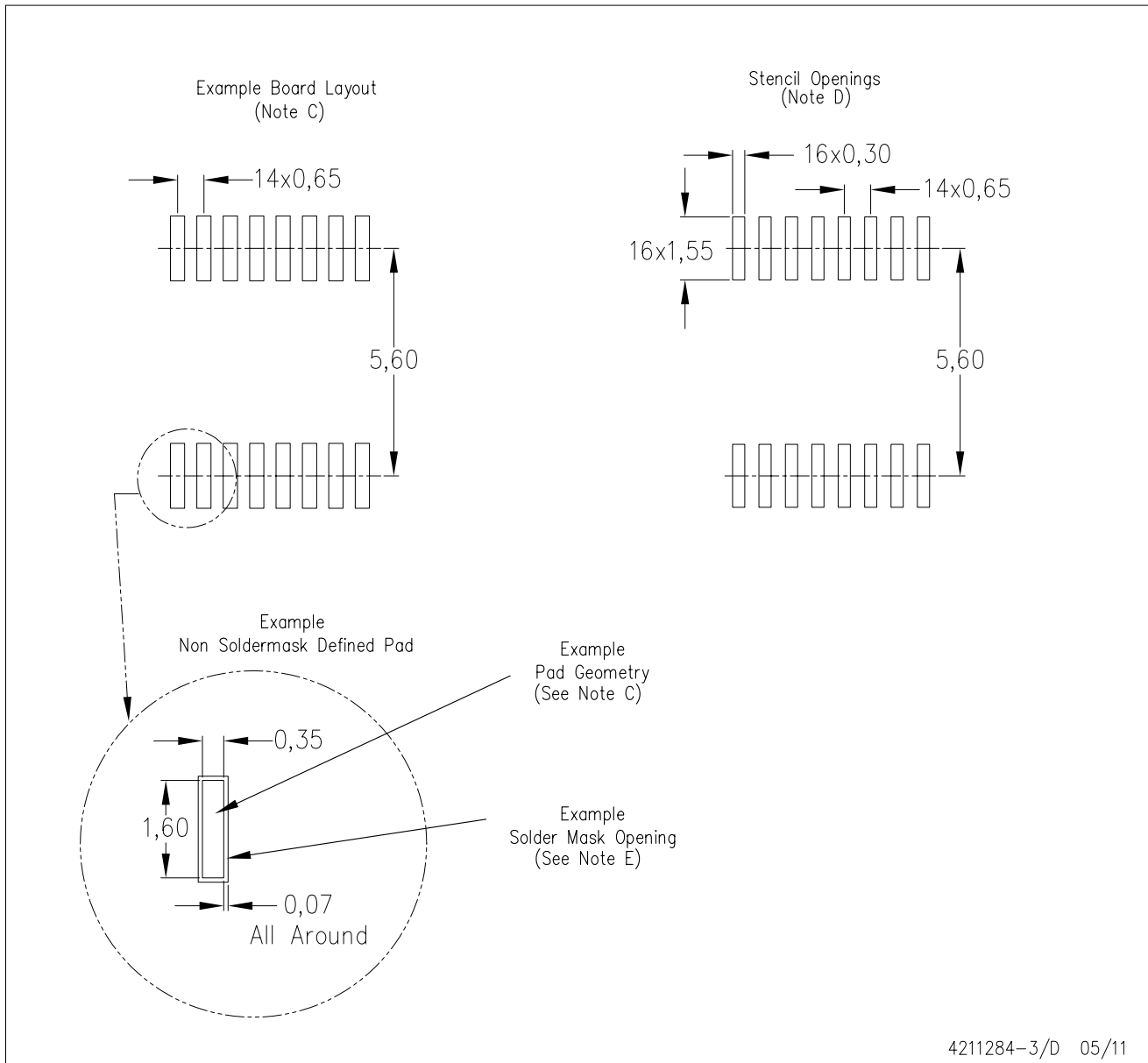

- NOTES:
- All linear dimensions are in millimeters.
 - This drawing is subject to change without notice.
 - Publication IPC-7351 is recommended for alternate designs.
 - Laser cutting apertures with trapezoidal walls and also rounding corners will offer better paste release. Customers should contact their board assembly site for stencil design recommendations. Refer to IPC-7525 for other stencil recommendations.
 - Customers should contact their board fabrication site for solder mask tolerances between and around signal pads.

RSA (S-PVQFN-N16)

PLASTIC QUAD FLATPACK NO-LEAD

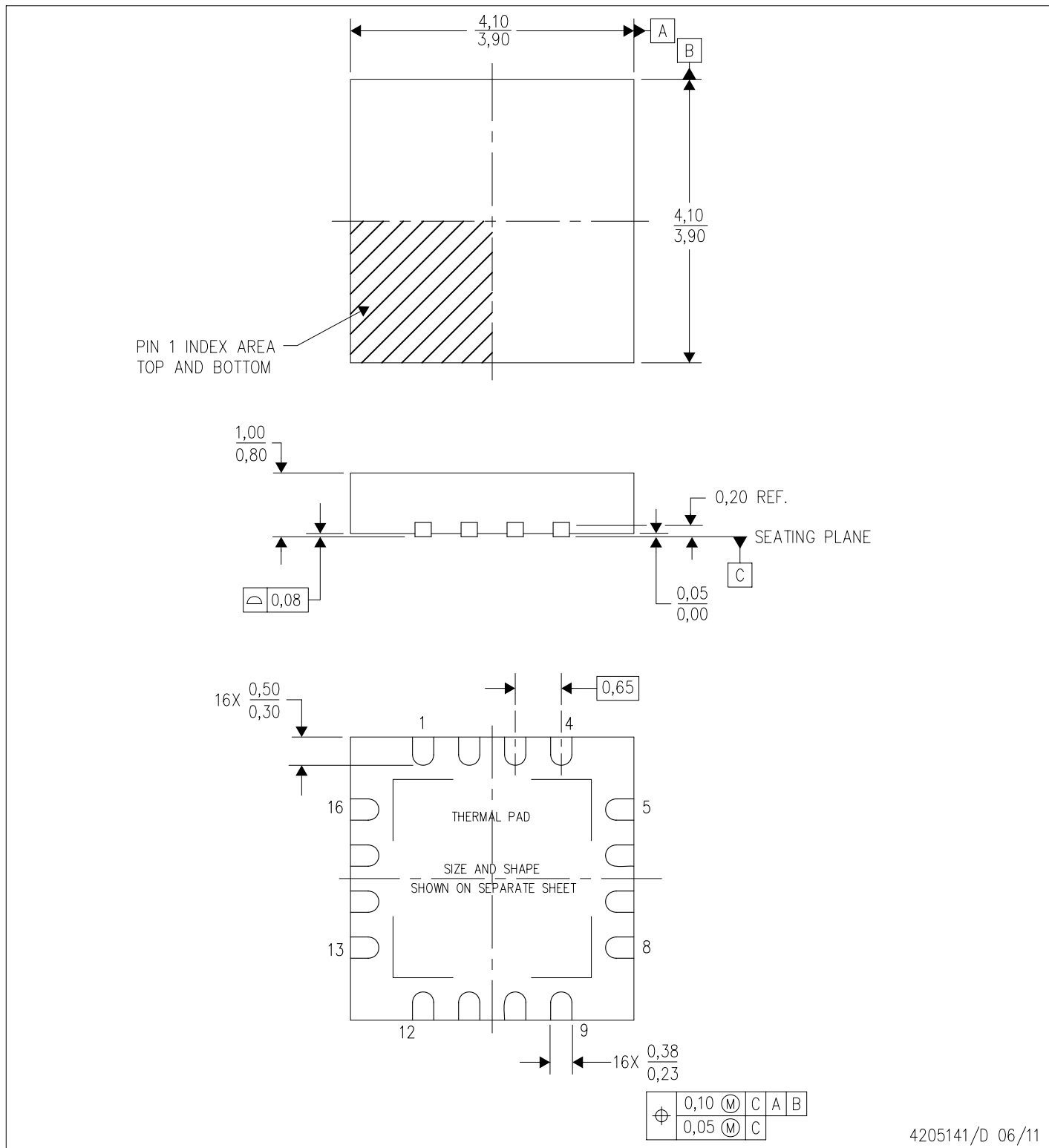

- NOTES:
- All linear dimensions are in millimeters. Dimensioning and tolerancing per ASME Y14.5M-1994.
 - This drawing is subject to change without notice.
 - Quad Flatpack, No-leads (QFN) package configuration.
 - The package thermal pad must be soldered to the board for thermal and mechanical performance.
 - See the additional figure in the Product Data Sheet for details regarding the exposed thermal pad features and dimensions.
 - Falls within JEDEC MO-220.

THERMAL INFORMATION

This package incorporates an exposed thermal pad that is designed to be attached directly to an external heatsink. The thermal pad must be soldered directly to the printed circuit board (PCB). After soldering, the PCB can be used as a heatsink. In addition, through the use of thermal vias, the thermal pad can be attached directly to the appropriate copper plane shown in the electrical schematic for the device, or alternatively, can be attached to a special heatsink structure designed into the PCB. This design optimizes the heat transfer from the integrated circuit (IC).

For information on the Quad Flatpack No-Lead (QFN) package and its advantages, refer to Application Report, QFN/SON PCB Attachment, Texas Instruments Literature No. SLUA271. This document is available at www.ti.com.

The exposed thermal pad dimensions for this package are shown in the following illustration.

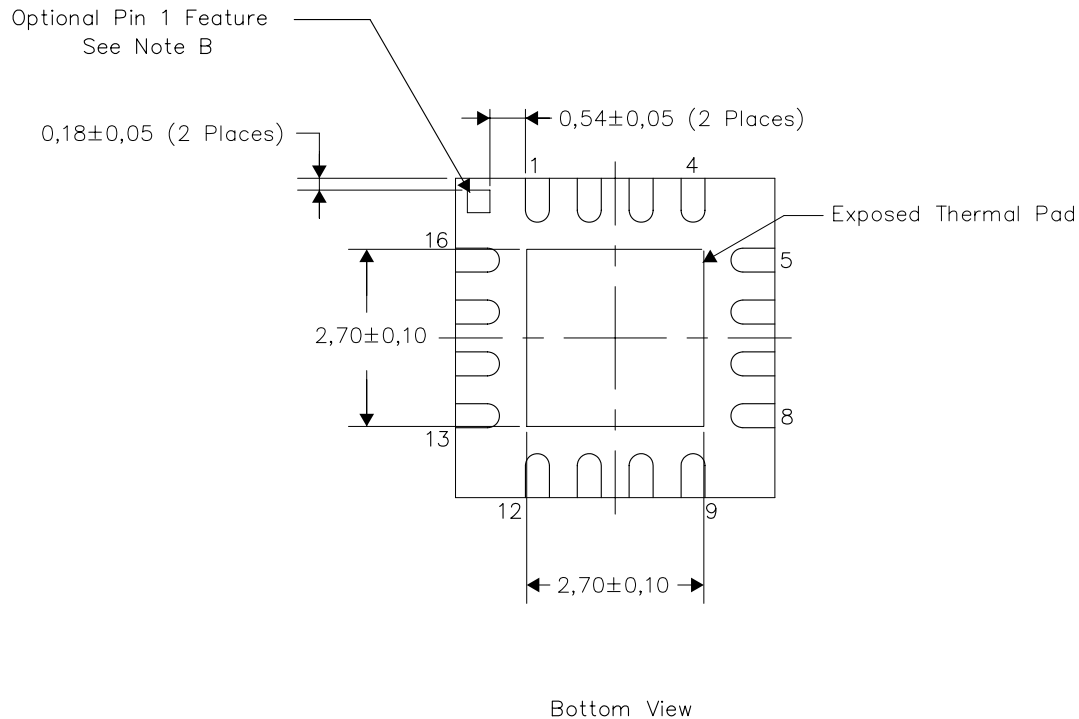

Exposed Thermal Pad Dimensions

4206364/K 06/11

NOTES:

- A. All linear dimensions are in millimeters
- B. The Pin 1 Identification mark is an optional feature that may be present on some devices
In addition, this Pin 1 feature if present is electrically connected to the center thermal pad and therefore should be considered when routing the board layout.

RSA (S-PVQFN-N16)

PLASTIC QUAD FLATPACK NO-LEAD

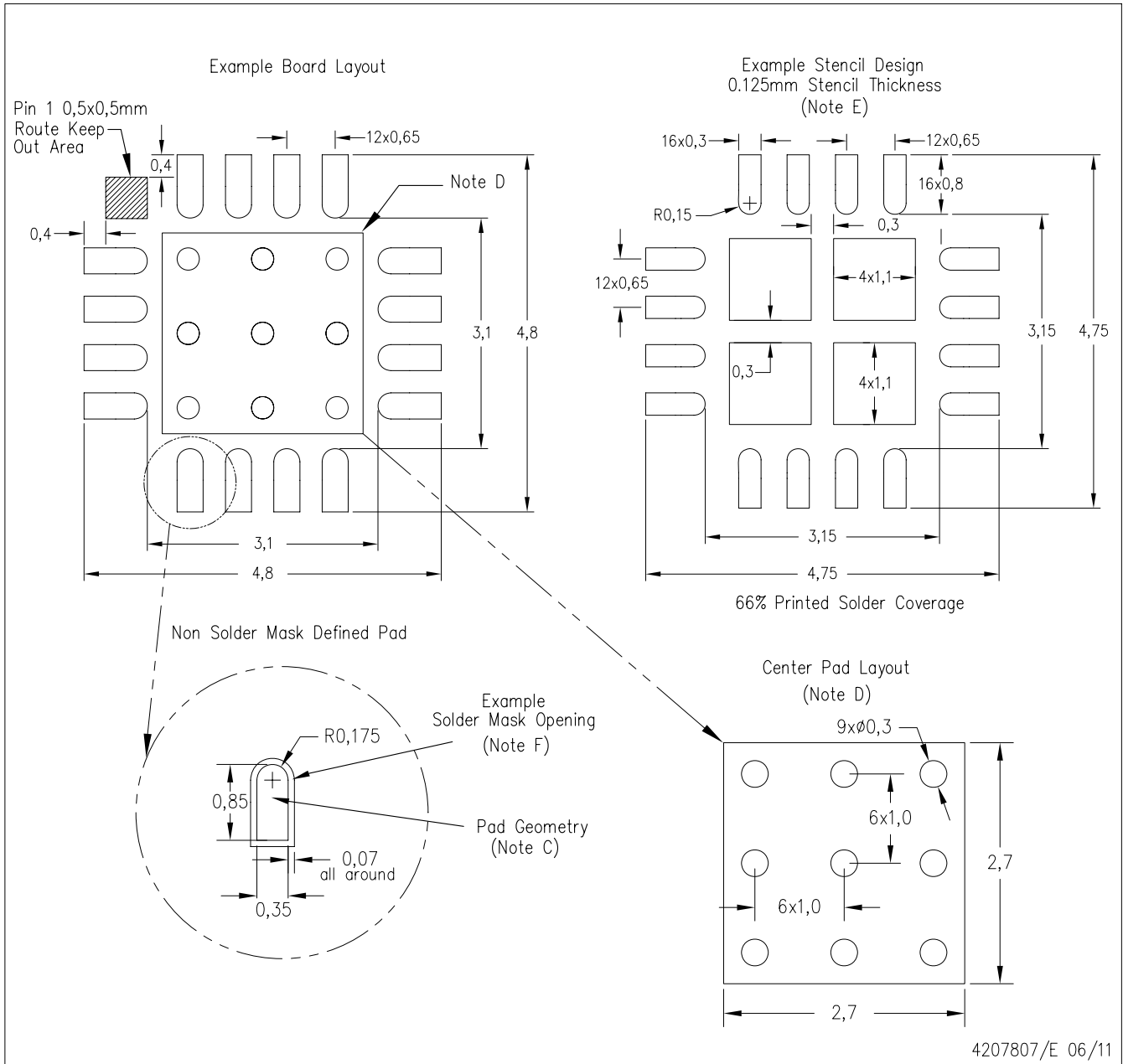

- NOTES:
- A. All linear dimensions are in millimeters.
 - B. This drawing is subject to change without notice.
 - C. Publication IPC-7351 is recommended for alternate designs.
 - D. This package is designed to be soldered to a thermal pad on the board. Refer to Application Note, QFN Packages, Texas Instruments Literature No. SLUA271, and also the Product Data Sheets for specific thermal information, via requirements, and recommended board layout. These documents are available at www.ti.com <<http://www.ti.com>>.
 - E. Laser cutting apertures with trapezoidal walls and also rounding corners will offer better paste release. Customers should contact their board assembly site for stencil design recommendations. Refer to IPC 7525 for stencil design considerations.
 - F. Customers should contact their board fabrication site for solder mask tolerances.

IMPORTANT NOTICE

Texas Instruments Incorporated and its subsidiaries (TI) reserve the right to make corrections, modifications, enhancements, improvements, and other changes to its products and services at any time and to discontinue any product or service without notice. Customers should obtain the latest relevant information before placing orders and should verify that such information is current and complete. All products are sold subject to TI's terms and conditions of sale supplied at the time of order acknowledgment.

TI warrants performance of its hardware products to the specifications applicable at the time of sale in accordance with TI's standard warranty. Testing and other quality control techniques are used to the extent TI deems necessary to support this warranty. Except where mandated by government requirements, testing of all parameters of each product is not necessarily performed.

TI assumes no liability for applications assistance or customer product design. Customers are responsible for their products and applications using TI components. To minimize the risks associated with customer products and applications, customers should provide adequate design and operating safeguards.

TI does not warrant or represent that any license, either express or implied, is granted under any TI patent right, copyright, mask work right, or other TI intellectual property right relating to any combination, machine, or process in which TI products or services are used. Information published by TI regarding third-party products or services does not constitute a license from TI to use such products or services or a warranty or endorsement thereof. Use of such information may require a license from a third party under the patents or other intellectual property of the third party, or a license from TI under the patents or other intellectual property of TI.

Reproduction of TI information in TI data books or data sheets is permissible only if reproduction is without alteration and is accompanied by all associated warranties, conditions, limitations, and notices. Reproduction of this information with alteration is an unfair and deceptive business practice. TI is not responsible or liable for such altered documentation. Information of third parties may be subject to additional restrictions.

Resale of TI products or services with statements different from or beyond the parameters stated by TI for that product or service voids all express and any implied warranties for the associated TI product or service and is an unfair and deceptive business practice. TI is not responsible or liable for any such statements.

TI products are not authorized for use in safety-critical applications (such as life support) where a failure of the TI product would reasonably be expected to cause severe personal injury or death, unless officers of the parties have executed an agreement specifically governing such use. Buyers represent that they have all necessary expertise in the safety and regulatory ramifications of their applications, and acknowledge and agree that they are solely responsible for all legal, regulatory and safety-related requirements concerning their products and any use of TI products in such safety-critical applications, notwithstanding any applications-related information or support that may be provided by TI. Further, Buyers must fully indemnify TI and its representatives against any damages arising out of the use of TI products in such safety-critical applications.

TI products are neither designed nor intended for use in military/aerospace applications or environments unless the TI products are specifically designated by TI as military-grade or "enhanced plastic." Only products designated by TI as military-grade meet military specifications. Buyers acknowledge and agree that any such use of TI products which TI has not designated as military-grade is solely at the Buyer's risk, and that they are solely responsible for compliance with all legal and regulatory requirements in connection with such use.

TI products are neither designed nor intended for use in automotive applications or environments unless the specific TI products are designated by TI as compliant with ISO/TS 16949 requirements. Buyers acknowledge and agree that, if they use any non-designated products in automotive applications, TI will not be responsible for any failure to meet such requirements.

Following are URLs where you can obtain information on other Texas Instruments products and application solutions:

Products

Audio	www.ti.com/audio
Amplifiers	amplifier.ti.com
Data Converters	dataconverter.ti.com
DLP® Products	www.dlp.com
DSP	dsp.ti.com
Clocks and Timers	www.ti.com/clocks
Interface	interface.ti.com
Logic	logic.ti.com
Power Mgmt	power.ti.com
Microcontrollers	microcontroller.ti.com
RFID	www.ti-rfid.com
RF/IF and ZigBee® Solutions	www.ti.com/lprf

Applications

Communications and Telecom	www.ti.com/communications
Computers and Peripherals	www.ti.com/computers
Consumer Electronics	www.ti.com/consumer-apps
Energy and Lighting	www.ti.com/energy
Industrial	www.ti.com/industrial
Medical	www.ti.com/medical
Security	www.ti.com/security
Space, Avionics and Defense	www.ti.com/space-avionics-defense
Transportation and Automotive	www.ti.com/automotive
Video and Imaging	www.ti.com/video
Wireless	www.ti.com/wireless-apps

TI E2E Community Home Page

e2e.ti.com

Mailing Address: Texas Instruments, Post Office Box 655303, Dallas, Texas 75265
Copyright © 2011, Texas Instruments Incorporated