

DUAL-OUTPUT, LOW DROPOUT VOLTAGE REGULATORS WITH INTEGRATED SVS FOR SPLIT VOLTAGE SYSTEMS

 Check for Samples: [TPS70445](#), [TPS70448](#), [TPS70451](#), [TPS70458](#), [TPS70402](#)

FEATURES

- Dual Output Voltages for Split-Supply Applications
- Independent Enable Functions (See Part Number [TPS703xx](#) for Sequenced Outputs)
- Output Current Range of 1 A on Regulator 1 and 2 A on Regulator 2
- Fast Transient Response
- Voltage Options: 3.3-V/2.5-V, 3.3-V/1.8-V, 3.3-V/1.5-V, 3.3-V/1.2-V, and Dual Adjustable Outputs
- Open Drain Power-On Reset with 120-ms Delay
- Open Drain Power Good for Regulator 1 and Regulator 2
- Ultralow 185 μ A (typ) Quiescent Current
- 2 μ A Input Current During Standby
- Low Noise: 78 μ V_{RMS} Without Bypass Capacitor
- Quick Output Capacitor Discharge Feature
- One Manual Reset Input
- 2% Accuracy Over Load and Temperature
- Undervoltage Lockout (UVLO) Feature
- 24-Pin PowerPAD™ TSSOP Package
- Thermal Shutdown Protection

DESCRIPTION

The TPS704xx family of devices consists of dual-output, low-dropout voltage regulators with integrated SVS (RESET, POR, or power on reset) and power good (PG) functions. These devices are capable of supplying 1 A and 2 A by regulator 1 and regulator 2 respectively. Quiescent current is typically 185 μ A at full load. Differentiated features, such as accuracy, fast transient response, SVS supervisory circuit (power on reset), manual reset input, and independent enable functions provide a complete system solution.

PWP PACKAGE
(TOP VIEW)

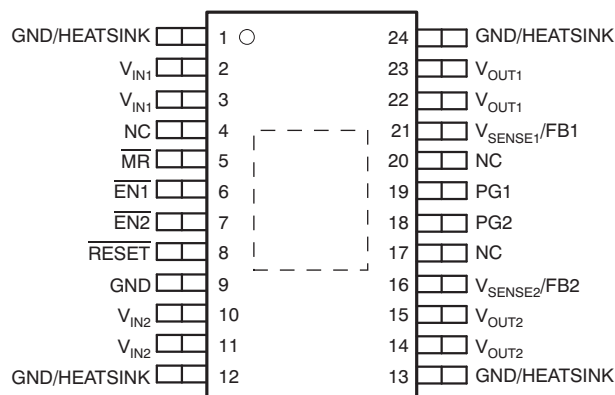

NC = No internal connection

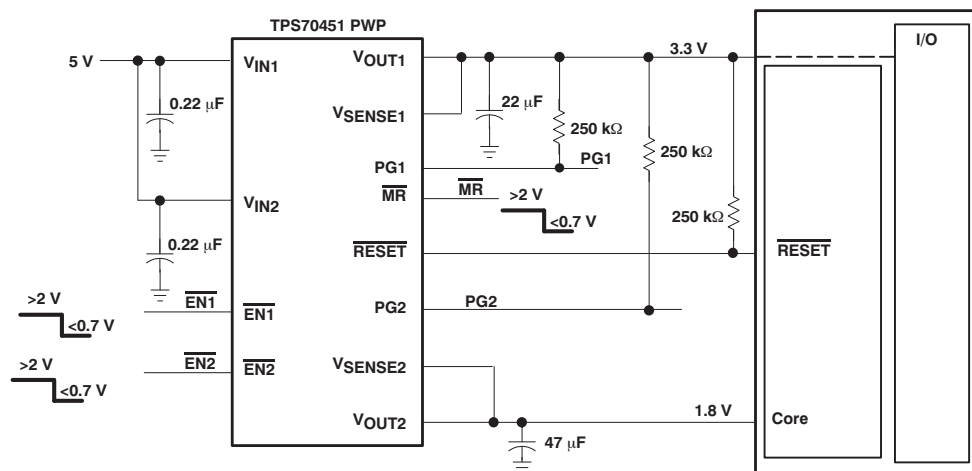

Please be aware that an important notice concerning availability, standard warranty, and use in critical applications of Texas Instruments semiconductor products and disclaimers thereto appears at the end of this data sheet.

PowerPAD is a trademark of Texas Instruments.
All other trademarks are the property of their respective owners.

The TPS704xx family of voltage regulators offers very low dropout voltage and dual outputs. These devices have extremely low noise output performance without using any added filter bypass capacitors and are designed to have a fast transient response and be stable with 47- μ F low ESR capacitors.

These devices have fixed 3.3-V/2.5-V, 3.3-V/1.8-V, 3.3-V/1.5-V, 3.3-V/1.2-V, and adjustable voltage options. Regulator 1 can support up to 1 A, and regulator 2 can support up to 2 A. Separate voltage inputs allow the designer to configure the source power.

Because the PMOS device behaves as a low-value resistor, the dropout voltage is very low (typically 160 mV on regulator 1) and is directly proportional to the output current. Additionally, since the PMOS pass element is a voltage-driven device, the quiescent current is very low and independent of output loading (maximum of 250 μ A over the full range of output current and full range of temperature). This LDO family also features a sleep mode; applying a high signal to EN1 or EN2 (enable) shuts down regulator 1 or regulator 2, respectively. When a high signal is applied to both EN1 and EN2, both regulators enter sleep mode, thereby reducing the input current to 2 μ A at $T_J = +25^\circ\text{C}$.

For each regulator, there is an internal discharge transistor to discharge the output capacitor when the regulator is turned off (disabled).

The PG1 pin reports the voltage condition at V_{OUT1} . The PG1 pin can be used to implement a SVS (RESET, POR, or power on reset) for the circuitry supplied by regulator 1. The PG2 pin reports the voltage conditions at V_{OUT2} . The PG2 pin can be used to implement a SVS (power on reset) for the circuitry supplied by regulator 2.

The TPS704xx features a RESET (SVS, POR, or power on reset). RESET is an active low, open drain output and requires a pull-up resistor for normal operation. When pulled up, RESET goes into a high impedance state (that is, logic high) after a 120-ms delay when both of the following conditions are met. First, V_{IN1} must be above the undervoltage condition. Second, the manual reset (MR) pin must be in a high impedance state. To monitor V_{OUT1} , the PG1 output pin can be connected to MR. To monitor V_{OUT2} , the PG2 output pin can be connected to MR. RESET can be used to drive power on reset or a low-battery indicator. If RESET is not used, it can be left floating.

Internal bias voltages are powered by V_{IN1} and require 2.7 V for full functionality. Each regulator input has an undervoltage lockout circuit that prevents each output from turning on until the respective input reaches 2.5 V.



This integrated circuit can be damaged by ESD. Texas Instruments recommends that all integrated circuits be handled with appropriate precautions. Failure to observe proper handling and installation procedures can cause damage.

ESD damage can range from subtle performance degradation to complete device failure. Precision integrated circuits may be more susceptible to damage because very small parametric changes could cause the device not to meet its published specifications.

ORDERING INFORMATION⁽¹⁾

PRODUCT	VOLTAGE (V) ⁽²⁾		PACKAGE-LEAD (DESIGNATOR)	SPECIFIED TEMPERATURE RANGE (T _J)	ORDERING NUMBER	TRANSPORT MEDIA, QUANTITY
	V _{OUT1}	V _{OUT2}				
TPS70402	Adjustable	Adjustable	HTSSOP-24 (PWP)	–40°C to +125°C	TPS70402PWP	Tube, 60
					TPS70402PWPR	Tape and Reel, 2000
TPS70445	3.3 V	1.2 V	HTSSOP-24 (PWP)	–40°C to +125°C	TPS70445PWP	Tube, 60
					TPS70445PWPR	Tape and Reel, 2000
TPS70448	3.3 V	1.5 V	HTSSOP-24 (PWP)	–40°C to +125°C	TPS70448PWP	Tube, 60
					TPS70448PWPR	Tape and Reel, 2000
TPS70451	3.3 V	1.8 V	HTSSOP-24 (PWP)	–40°C to +125°C	TPS70451PWP	Tube, 60
					TPS70451PWPR	Tape and Reel, 2000
TPS70458	3.3 V	2.5 V	HTSSOP-24 (PWP)	–40°C to +125°C	TPS70458PWP	Tube, 60
					TPS70458PWPR	Tape and Reel, 2000

(1) For the most current package and ordering information, see the Package Option Addendum at the end of this document, or visit the device product folder at ti.com.

(2) For fixed 1.20 V operation, tie FB to OUT.

ABSOLUTE MAXIMUM RATINGS⁽¹⁾

Over operating free-air temperature range (unless otherwise noted).

	TPS704xx	UNIT
Input voltage range: V _{IN1} , V _{IN2} ⁽²⁾	–0.3 to +7	V
Voltage range at $\overline{EN1}$, $\overline{EN2}$	–0.3 to +7	V
Output voltage range (V _{OUT1} , V _{SENSE1})	5.5	V
Output voltage range (V _{OUT2} , V _{SENSE2})	5.5	V
Maximum RESET, PG1, PG2 voltage	7	V
Maximum MR voltage	V _{IN1}	V
Peak output current	Internally limited	—
Continuous total power dissipation	See Dissipation Ratings Table	—
Operating virtual junction temperature range, T _J	–40 to +150	°C
Storage temperature range, T _{stg}	–65 to +150	°C
ESD rating, HBM	2	kV

(1) Stresses beyond those listed under absolute maximum ratings may cause permanent damage to the device. These are stress ratings only, and functional operation of the device at these or any other conditions beyond those indicated under recommended operating conditions is not implied. Exposure to absolute-maximum-rated conditions for extended periods may affect device reliability.

(2) All voltages are tied to network ground.

DISSIPATION RATINGS

PACKAGE	AIR FLOW (CFM)	$T_A \leq +25^\circ\text{C}$	DERATING FACTOR	$T_A = +70^\circ\text{C}$	$T_A = +85^\circ\text{C}$
PWP ⁽¹⁾	0	3.067W	30.67mW/°C	1.687W	1.227W
	250	4.115W	41.15mW/°C	2.265W	1.646W

(1) This parameter is measured with the recommended copper heat sink pattern on a 4-layer PCB, 1 oz. copper on a 4-in by 4-in ground layer. For more information, refer to TI technical brief [SLMA002](#).

RECOMMENDED OPERATING CONDITIONS

Over operating temperature range (unless otherwise noted).

	MIN	MAX	UNIT
Input voltage, V_I ⁽¹⁾ (regulator 1 and 2)	2.7	6	V
Output current, I_O (regulator 1)	0	1	A
Output current, I_O (regulator 2)	0	2	A
Output voltage range (for adjustable option)	1.22	5.5	V
Operating virtual junction temperature, T_J	-40	+125	°C

(1) To calculate the minimum input voltage for maximum output current, use the following equation: $V_{I(\min)} = V_{O(\max)} + V_{DO(\max \text{ load})}$.

ELECTRICAL CHARACTERISTICS

Over recommended operating junction temperature range ($T_J = -40^\circ\text{C}$ to $+125^\circ\text{C}$), V_{IN1} or $V_{IN2} = V_{OUT(nom)} + 1\text{ V}$, $I_O = 1\text{ mA}$, $\overline{EN} = 0\text{ V}$, $C_{OUT1} = 22\text{ }\mu\text{F}$, and $C_{OUT2} = 47\text{ }\mu\text{F}$ (unless otherwise noted).

PARAMETER		TEST CONDITIONS		MIN	TYP	MAX	UNIT
V_O	Reference voltage	$2.7\text{ V} < V_{IN} < 6\text{ V}$, $T_J = +25^\circ\text{C}$	FB connected to V_O		1.22		V
		$2.7\text{ V} < V_{IN} < 6\text{ V}$,	FB connected to V_O	1.196		1.244	
	1.2 V Output (V_{OUT2})	$2.7\text{ V} < V_{IN} < 6\text{ V}$,	$T_J = +25^\circ\text{C}$		1.2		
		$2.7\text{ V} < V_{IN} < 6\text{ V}$,		1.176		1.224	
	1.5 V Output (V_{OUT2})	$2.7\text{ V} < V_{IN} < 6\text{ V}$,	$T_J = +25^\circ\text{C}$		1.5		
		$2.7\text{ V} < V_{IN} < 6\text{ V}$,		1.47		1.53	
	1.8 V Output (V_{OUT2})	$2.8\text{ V} < V_{IN} < 6\text{ V}$,	$T_J = +25^\circ\text{C}$		1.8		
		$2.8\text{ V} < V_{IN} < 6\text{ V}$,		1.764		1.836	
	2.5 V Output (V_{OUT2})	$3.5\text{ V} < V_{IN} < 6\text{ V}$,	$T_J = +25^\circ\text{C}$		2.5		
		$3.5\text{ V} < V_{IN} < 6\text{ V}$,		2.45		2.55	
3.3 V Output (V_{OUT2})	$4.3\text{ V} < V_{IN} < 6\text{ V}$,	$T_J = +25^\circ\text{C}$		3.3			
	$4.3\text{ V} < V_{IN} < 6\text{ V}$,		3.234		3.366		
Quiescent current (GND current) for regulator 1 and regulator 2, $\overline{EN1} = \overline{EN2} = 0\text{ V}^{(1)}$		See ⁽²⁾	$T_J = +25^\circ\text{C}$		185		μA
		See ⁽²⁾				250	
Output voltage line regulation ($\Delta V_O/V_O$) for regulator 1 and regulator 2 ⁽³⁾		$V_O + 1\text{ V} < V_{IN} \leq 6\text{ V}$,	$T_J = +25^\circ\text{C}^{(1)}$		0.01		%V
		$V_O + 1\text{ V} < V_{IN} \leq 6\text{ V}$	⁽¹⁾			0.1	
Load regulation for V_{OUT1} and V_{OUT2}		$T_J = +25^\circ\text{C}$			1		mV
V_n	Output noise voltage (TPS70451)	Regulator 1	BW = 300 Hz to 50 kHz, $C_O = 33\text{ }\mu\text{F}$, $T_J = +25^\circ\text{C}$		79		μV_{RMS}
		Regulator 2			77		
Output current limit		Regulator 1	$V_{OUT} = 0\text{ V}$		1.75	2.2	A
		Regulator 2			3.8	4.5	
Thermal shutdown junction temperature					+150		$^\circ\text{C}$
I_i	Standby current (standby)	Regulator 1	$\overline{EN1} = V_{IN}$, $\overline{EN2} = V_{IN}$	$T_J = +25^\circ\text{C}$	1	2	μA
		Regulator 2	$\overline{EN1} = V_{IN}$, $\overline{EN2} = V_{IN}$			10	
PSRR	Power-supply ripple rejection (TPS70451)	Regulator 1	$f = 1\text{ kHz}$	$T_J = +25^\circ\text{C}^{(1)}$	65		dB
		Regulator 2	$f = 1\text{ kHz}$	$T_J = +25^\circ\text{C}^{(1)}$	60		
RESET Terminal							
Minimum input voltage for valid $\overline{\text{RESET}}$		$I_{\text{RESET}} = 300\text{ }\mu\text{A}$, $V_{(\text{RESET})} \leq 0.8\text{ V}$			1.0	1.3	V
$t_{(\text{RESET})}$		$\overline{\text{RESET}}$ pulse duration			80	120	160
Output low voltage		$V_{IN} = 3.5\text{ V}$, $I_{(\text{RESET})} = 1\text{ mA}$			0.15	0.4	V
Leakage current		$V_{(\text{RESET})} = 6\text{ V}$				1	μA

(1) Minimum input operating voltage is 2.7 V or $V_{O(\text{typ})} + 1\text{ V}$, whichever is greater. Maximum input voltage = 6 V , minimum output current = 1 mA .

(2) $I_O = 1\text{ mA}$ to 1 A for Regulator 1 and 1 mA to 2 A for Regulator 2.

(3) If $V_O < 1.8\text{ V}$ then $V_{\text{Imax}} = 6\text{ V}$, $V_{\text{Imin}} = 2.7\text{ V}$:
 Line regulation (mV) = (%/V) $\times V_O \times \frac{(V_{\text{Imax}} - 2.7)}{100} \times 1000$
 If $V_O > 2.5\text{ V}$ then $V_{\text{Imax}} = 6\text{ V}$, $V_{\text{Imin}} = V_O + 1\text{ V}$:
 Line regulation (mV) = (%/V) $\times V_O \times \frac{[V_{\text{Imax}} - (V_O + 1)]}{100} \times 1000$

ELECTRICAL CHARACTERISTICS (continued)

Over recommended operating junction temperature range ($T_J = -40^\circ\text{C}$ to $+125^\circ\text{C}$), V_{IN1} or $V_{IN2} = V_{OUT(nom)} + 1\text{ V}$,
 $I_O = 1\text{ mA}$,
 $\overline{EN} = 0\text{ V}$, $C_{OUT1} = 22\text{ }\mu\text{F}$, and $C_{OUT2} = 47\text{ }\mu\text{F}$ (unless otherwise noted).

PARAMETER	TEST CONDITIONS	MIN	TYP	MAX	UNIT
V_{IN1}/V_{IN2} Terminal					
UVLO threshold		2.4		2.65	V
UVLO hysteresis			110		mV
PG1/PG2 Terminal					
Minimum input voltage for valid PGx	$I_{(PGx)} = 300\text{ }\mu\text{A}$, $V_{(PGx)} \leq 0.8\text{ V}$		1.0	1.3	V
Trip threshold voltage	V_O decreasing	92	95	98	% V_{OUT}
Hysteresis voltage	Measured at V_O		0.5		% V_{OUT}
$t_{r(PGx)}$	Rising edge deglitch		30		μs
Output low voltage	$V_{IN} = 2.7\text{ V}$, $I_{(PGx)} = 1\text{ mA}$		0.15	0.4	V
Leakage current	$V_{(PGx)} = 6\text{ V}$			1	μA
EN1/EN2 Terminal					
High-level \overline{ENx} input voltage		2			V
Low-level \overline{ENx} input voltage				0.7	V
Input current (\overline{ENx})		-1		1	μA
MR Terminal					
High-level input voltage		2			V
Low-level input voltage				0.7	V
Pull-up current source			6		μA
V_{OUT1} Terminal					
Dropout voltage ⁽⁴⁾	$I_O = 1\text{ A}$, $V_{IN1} = 3.2\text{ V}$ $T_J = +25^\circ\text{C}$		160		mV
	$I_O = 1\text{ A}$, $V_{IN1} = 3.2\text{ V}$			250	
Peak output current	2 ms pulse width		1.2		A
Discharge transistor current	$V_{OUT1} = 1.5\text{ V}$		7.5		mA
V_{OUT2} Terminal					
Peak output current	2 ms pulse width		3		A
Discharge transistor current	$V_{OUT2} = 1.5\text{ V}$		7.5		mA
FB Terminal					
Input current: TPS70402	FB = 1.8 V			1	μA

(4) Input voltage (V_{IN1} or V_{IN2}) = $V_{O(typ)} - 100\text{ mV}$. For 1.5-V, 1.8-V, and 2.5-V regulators, the dropout voltage is limited by input voltage range. The 3.3-V regulator input is set to 3.2 V to perform this test.

DEVICE INFORMATION

Fixed Voltage Version

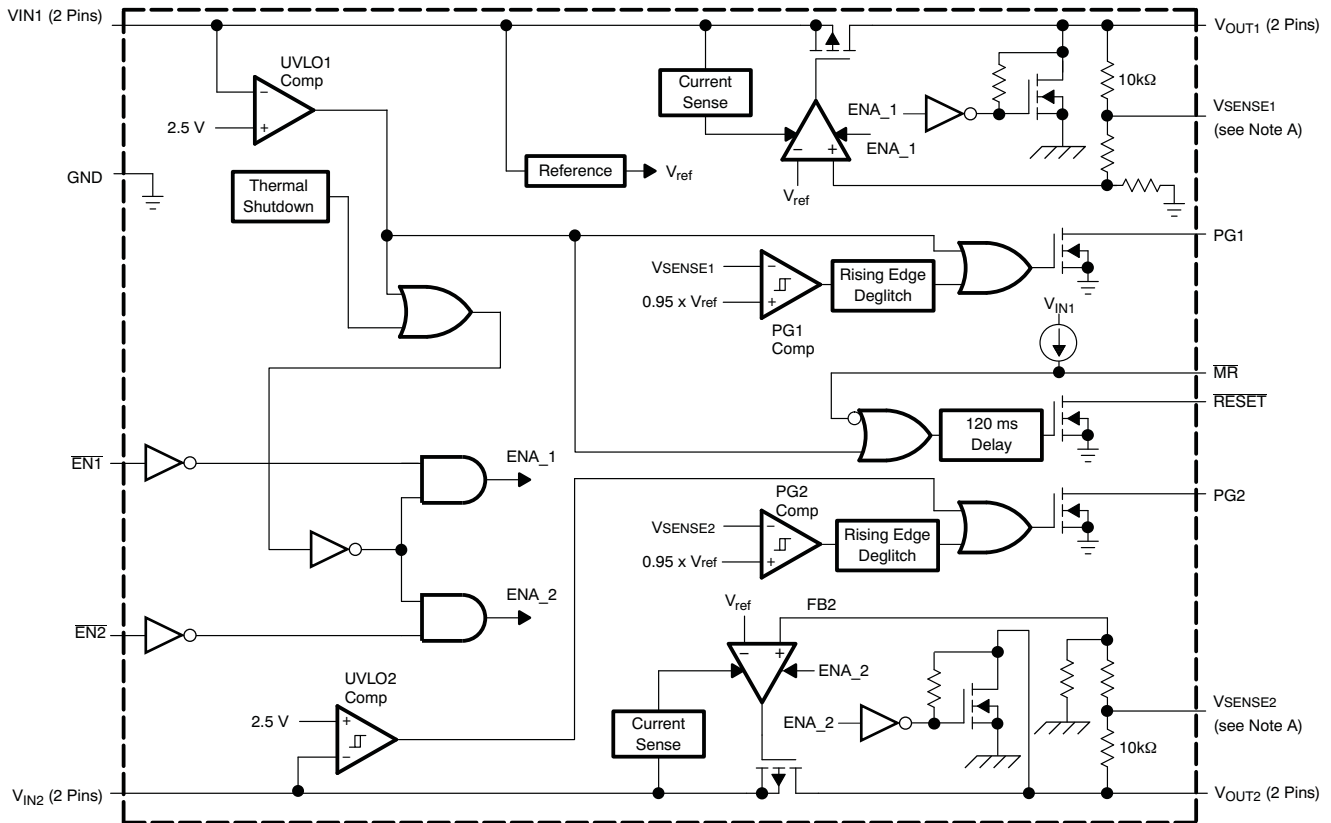

- A. For most applications, V_{SENSE1} and V_{SENSE2} should be externally connected to V_{OUT1} and V_{OUT2} , respectively, as close as possible to the device. For other implementations, refer to SENSE terminal connection discussion in the [Application Information](#) section.

Adjustable Voltage Version

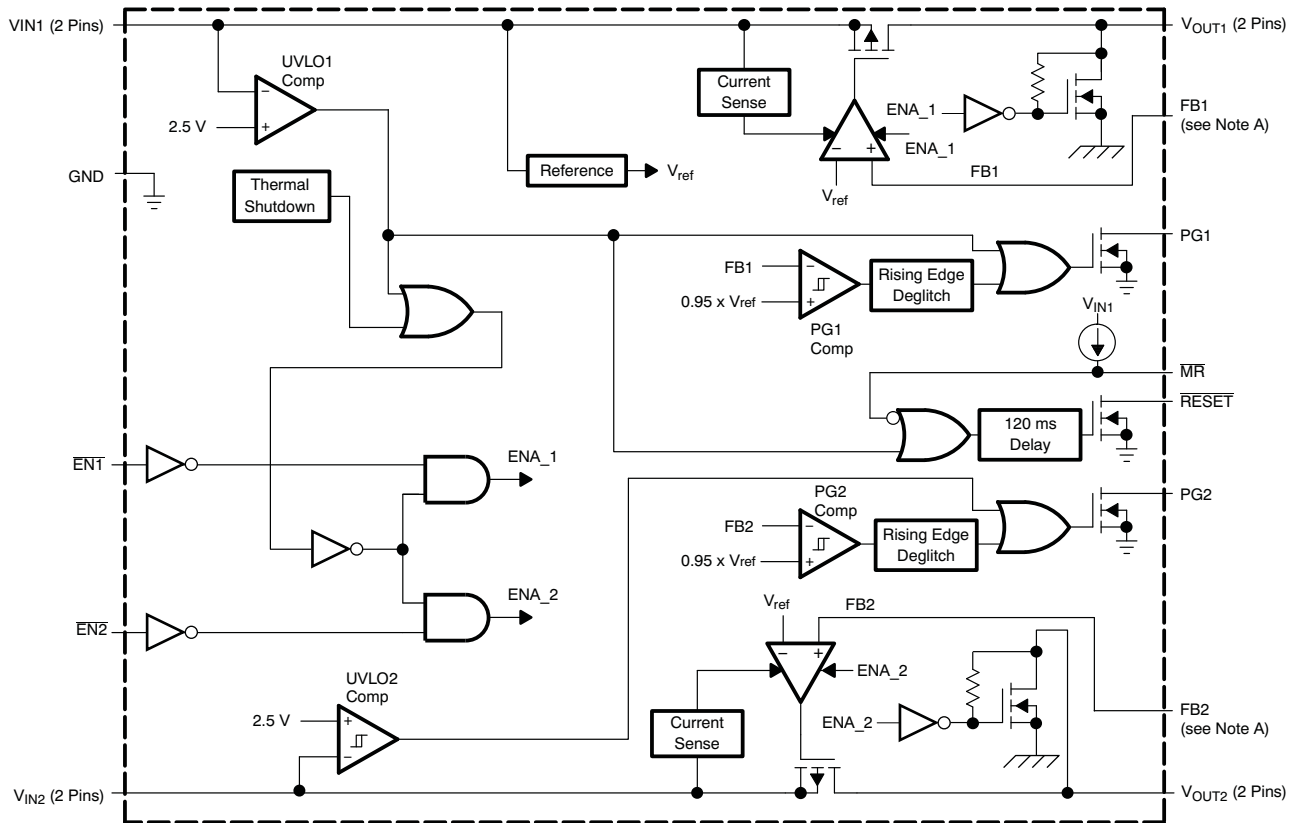

- A. For most applications, FB1 and FB2 should be externally connected to resistor dividers as close as possible to the device. For other implementations, refer to FB terminals connection discussion in the [Application Information](#) section.

RESET Timing Diagram

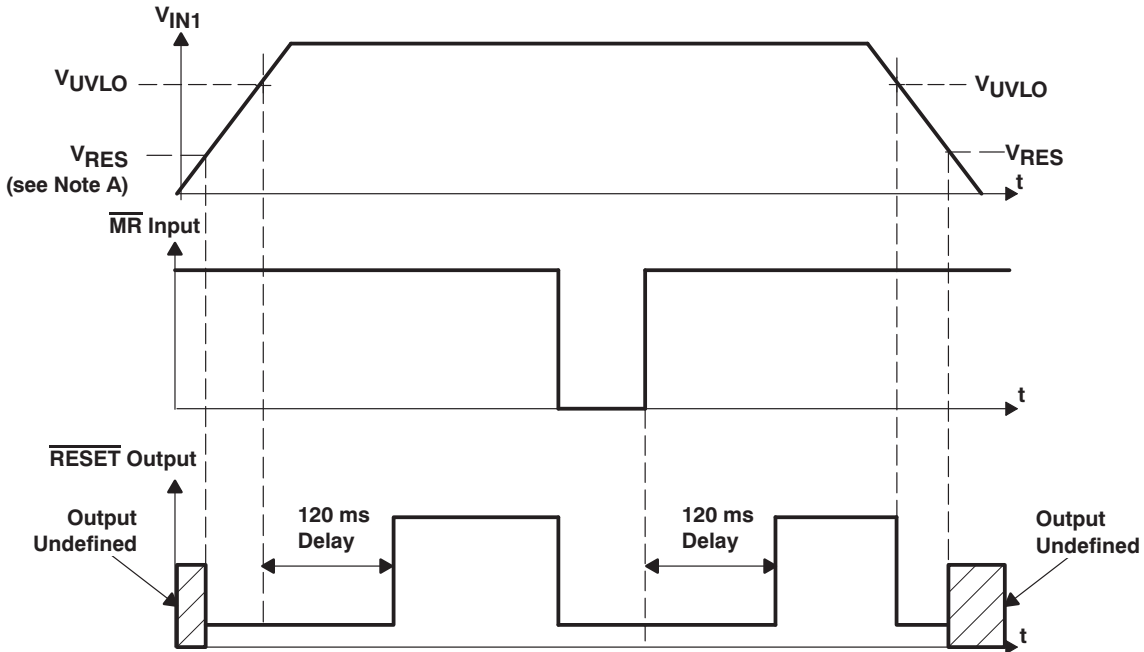

NOTE A: V_{RES} is the minimum input voltage for a valid \overline{RESET} . The symbol V_{RES} is not currently listed within EIA or JEDEC standards for semiconductor symbology.

PG1 Timing Diagram

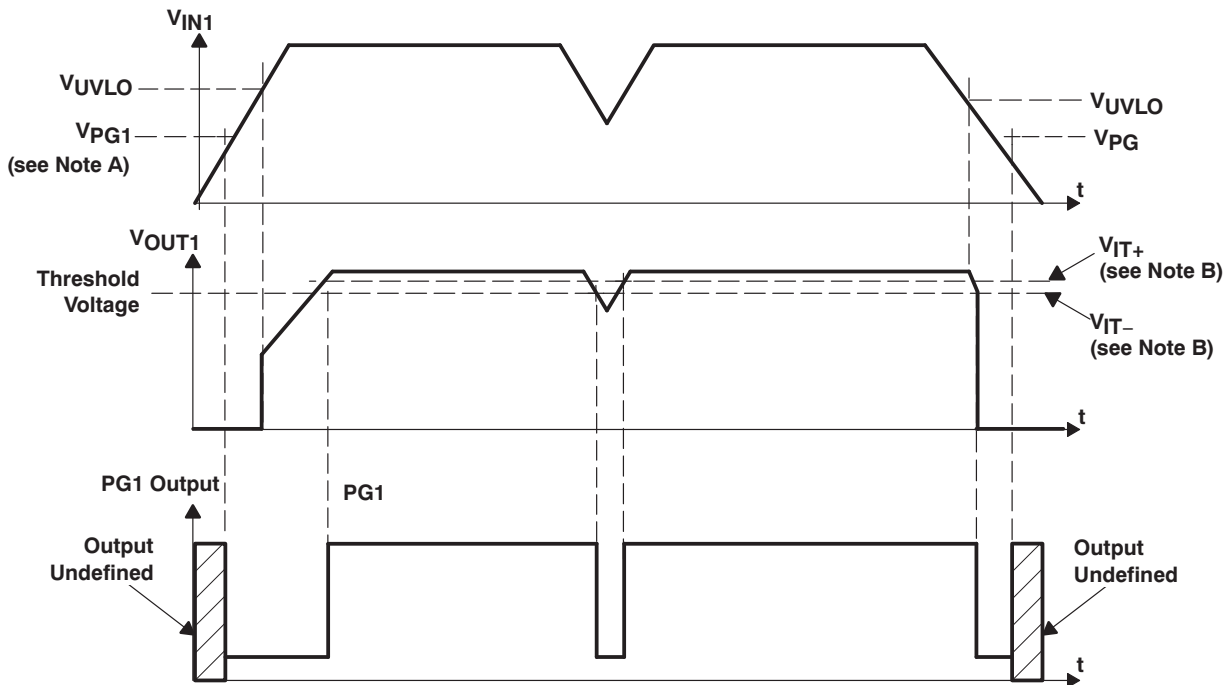

NOTES A: V_{PG1} is the minimum input voltage for a valid PG. The symbol V_{PG1} is not currently listed within EIA or JEDEC standards for semiconductor symbology.

B: V_{IT-} trip voltage is typically 5% lower than the output voltage ($95\%V_O$). V_{IT-} to V_{IT+} is the hysteresis voltage.

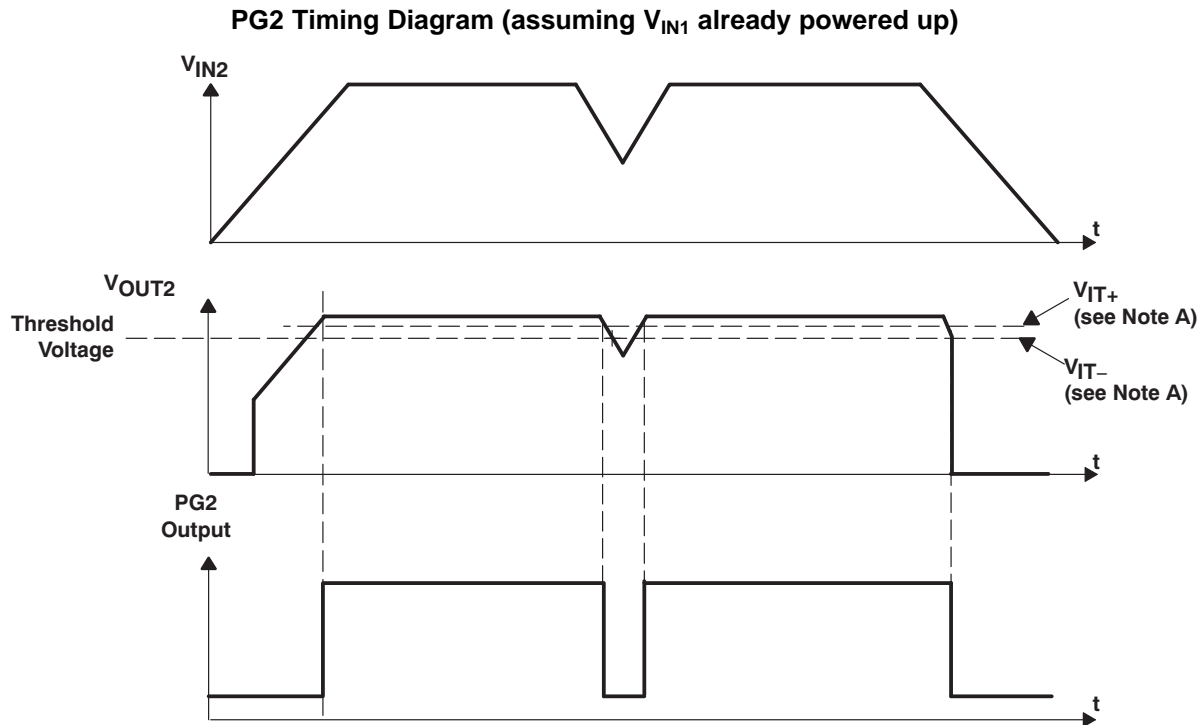

NOTE A: V_{IT-} trip voltage is typically 5% lower than the output voltage ($95\%V_O$). V_{IT-} to V_{IT+} is the hysteresis voltage.

TERMINAL FUNCTIONS

TERMINAL		I/O	DESCRIPTION
NAME	NO.		
$\overline{EN1}$	6	I	Active low enable for V_{OUT1}
$\overline{EN2}$	7	I	Active low enable for V_{OUT2}
GND	9	—	Ground
GND/HEATSINK	1, 12, 13, 24	—	Ground/heatsink
\overline{MR}	5	I	Manual reset input, active low, pulled up internally
NC	4, 17, 20	—	No connection
PG1	19	O	Open drain output, low when V_{OUT1} voltage is less than 95% of the nominal regulated voltage
PG2	18	O	Open drain output, low when V_{OUT2} voltage is less than 95% of the nominal regulated voltage
\overline{RESET}	8	O	Open drain output, SVS (power-on reset) signal, active low
V_{IN1}	2, 3	I	Input voltage of regulator 1
V_{IN2}	10, 11	I	Input voltage of regulator 2
V_{OUT1}	22, 23	O	Output voltage of regulator 1
V_{OUT2}	14, 15	O	Output voltage of regulator 2
$V_{SENSE1}/FB1$	21	I	Regulator 1 output voltage sense/regulator 1 feedback for adjustable
$V_{SENSE2}/FB2$	16	I	Regulator 2 output voltage sense/regulator 2 feedback for adjustable

Detailed Description

The TPS704xx low dropout regulator family provides dual regulated output voltages with independent enable functions. These devices provide fast transient response and high accuracy with small output capacitors, while drawing low quiescent current. Other features are integrated SVS (power-on reset, $\overline{\text{RESET}}$) and power good (PG1, PG2) that monitor output voltages and provide logic output to the system. These differentiated features provide a complete power solution.

The TPS704xx, unlike many other LDOs, features very low quiescent current that remains virtually constant even with varying loads. Conventional LDO regulators use a PNP pass element, the base current of which is directly proportional to the load current through the regulator ($I_B = I_C/\beta$). The TPS704xx uses a PMOS transistor to pass current; because the gate of the PMOS is voltage-driven, operating current is low and stable over the full load range.

Pin Functions

Enable ($\overline{\text{EN1}}$, $\overline{\text{EN2}}$)

The $\overline{\text{EN}}$ terminals are inputs that enable or shut down each respective regulator. If $\overline{\text{EN}}$ is at a voltage high signal, the respective regulator is in shutdown mode. When $\overline{\text{EN}}$ goes to voltage low, the respective regulator is enabled.

Power-Good (PG1, PG2)

The PG terminals are open drain, active high output terminals that indicate the status of each respective regulator. When V_{OUT1} reaches 95% of its regulated voltage, PG1 goes to a high impedance state. When V_{OUT2} reaches 95% of its regulated voltage, PG2 goes to a high impedance state. Each PG goes to a low impedance state when its respective output voltage is pulled below 95% (that is, goes to an overload condition) of its regulated voltage. The open drain outputs of the PG terminals require a pull-up resistor.

Manual Reset Pin

$\overline{\text{MR}}$ is an active low input terminal used to trigger a reset condition. When $\overline{\text{MR}}$ is pulled to logic low, a POR ($\overline{\text{RESET}}$) occurs. The terminal has a 6- μA pull-up current to V_{IN1} ; however, it is recommended that the pin be pulled high to V_{IN1} when it is not used.

Sense (V_{SENSE1} , V_{SENSE2})

The sense terminals of fixed-output options must be connected to the regulator outputs, and the connection should be as short as possible. Internally, the sense terminal connects to high-impedance, wide-bandwidth amplifiers through a resistor-divider network and noise pickup feeds through to the regulator output. It is essential to route the sense connection in such a way as to minimize or avoid noise pickup. Adding RC networks between sense terminals and V_{OUT} terminals to filter noise is not recommended because these networks can cause the regulators to oscillate.

FB1 and FB2

FB1 and FB2 are input terminals used for adjustable-output devices and must be connected to the external feedback resistor divider. FB1 and FB2 connections should be as short as possible. It is essential to route them in such a way as to minimize or avoid noise pickup. Adding RC networks between FB terminals and V_{OUT} terminals to filter noise is not recommended because these networks can cause the regulators to oscillate.

RESET Indicator

\overline{RESET} is an active low, open drain output and requires a pullup resistor for normal operation. When pulled up, \overline{RESET} goes into a high impedance state (that is, logic high) after a 120-ms delay when both of the following conditions are met. First, V_{IN1} must be above the undervoltage condition. Second, the manual reset (\overline{MR}) pin must be in a high impedance state. To monitor V_{OUT1} , the PG1 output pin can be connected to \overline{MR} . To monitor V_{OUT2} , the PG2 output pin can be connected to \overline{MR} . If \overline{RESET} is not used, it can be left floating.

V_{IN1} and V_{IN2}

V_{IN1} and V_{IN2} are inputs to each regulator. **Internal bias voltages are powered by V_{IN1} .**

V_{OUT1} and V_{OUT2}

V_{OUT1} and V_{OUT2} are output terminals of each regulator.

TYPICAL CHARACTERISTICS

Table of Graphs

			FIGURE
V_O	Output voltage	vs Output current	Figure 1 and Figure 2
		vs Junction temperature	Figure 3 to Figure 4
	Ground current	vs Junction temperature	Figure 5
PSRR	Power-supply rejection ratio	vs Frequency	Figure 6 to Figure 9
	Output spectral noise density	vs Frequency	Figure 10 to Figure 13
Z_O	Output impedance	vs Frequency	Figure 14 to Figure 17
	Dropout voltage	vs Temperature	Figure 18 and Figure 19
		vs Input voltage	Figure 20 and Figure 21
	Load transient response		Figure 22 and Figure 23
	Line transient response (V_{OUT1})		Figure 24
	Line transient response (V_{OUT2})		Figure 25
V_O	Output voltage	vs Time (start-up)	Figure 26 and Figure 27
		Equivalent series resistance (ESR)	Figure 29 to Figure 32

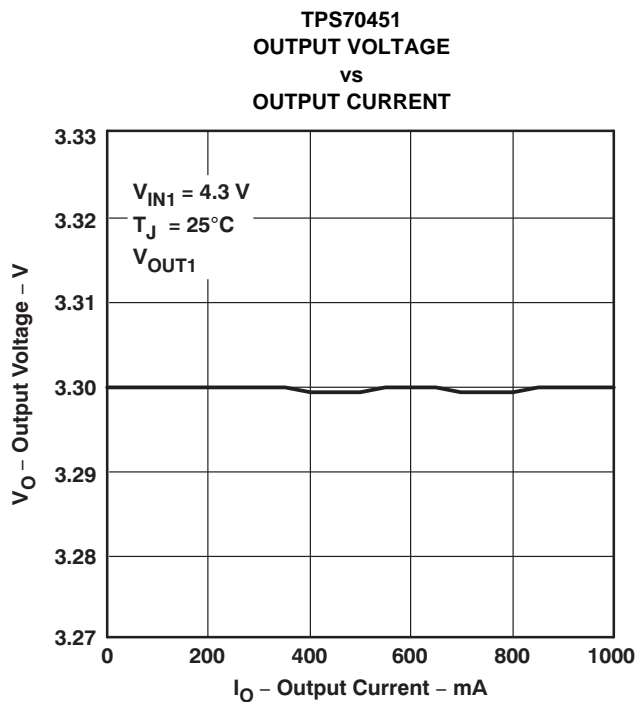

Figure 1.

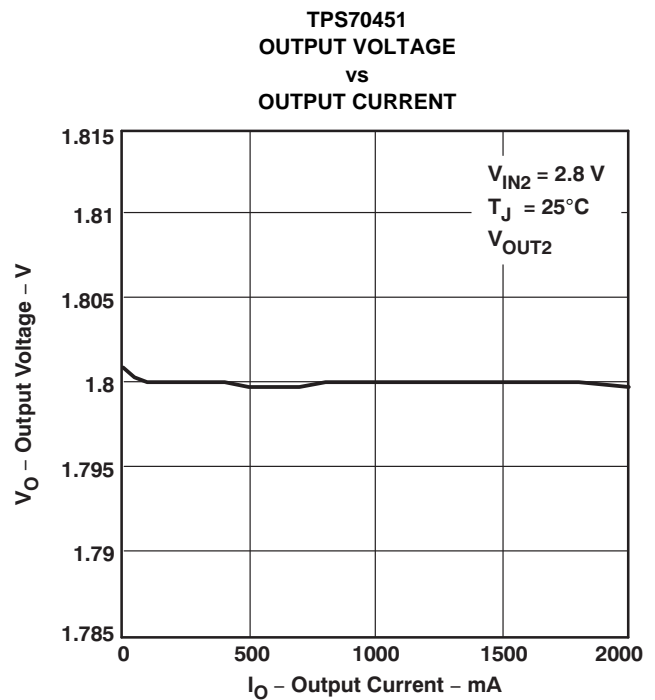

Figure 2.

TYPICAL CHARACTERISTICS (continued)

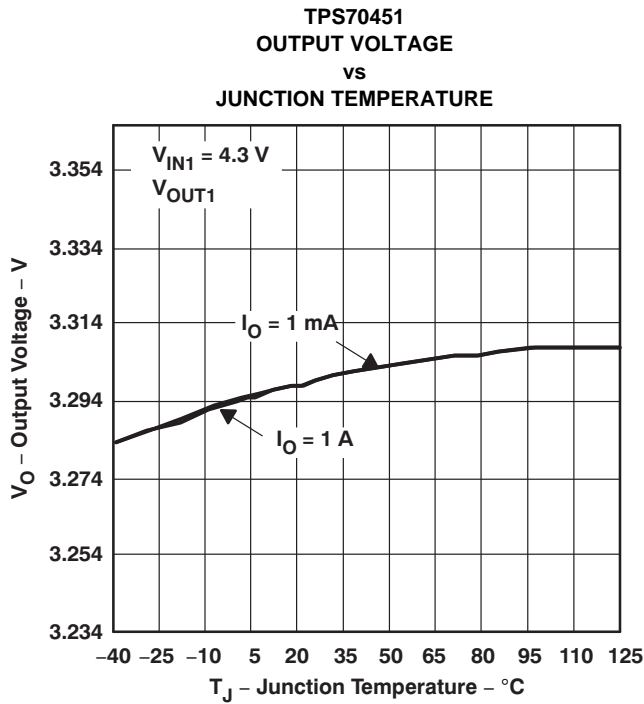

Figure 3.

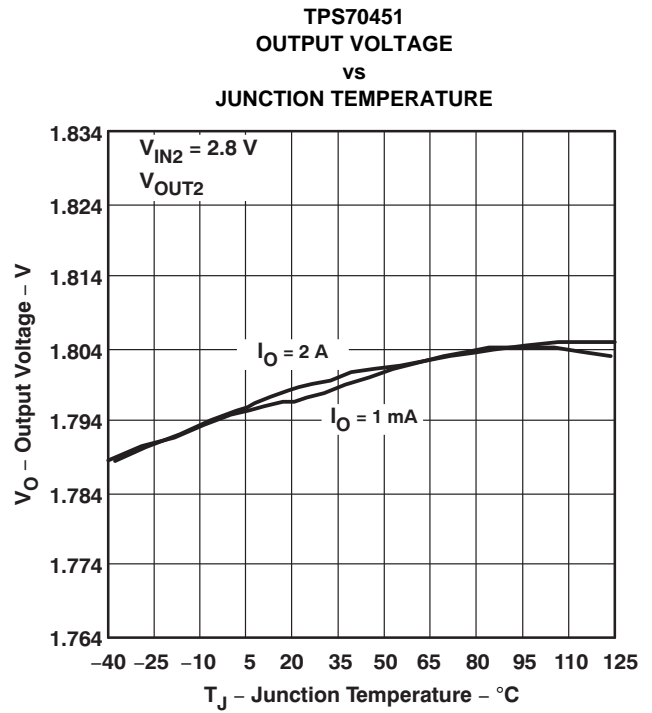

Figure 4.

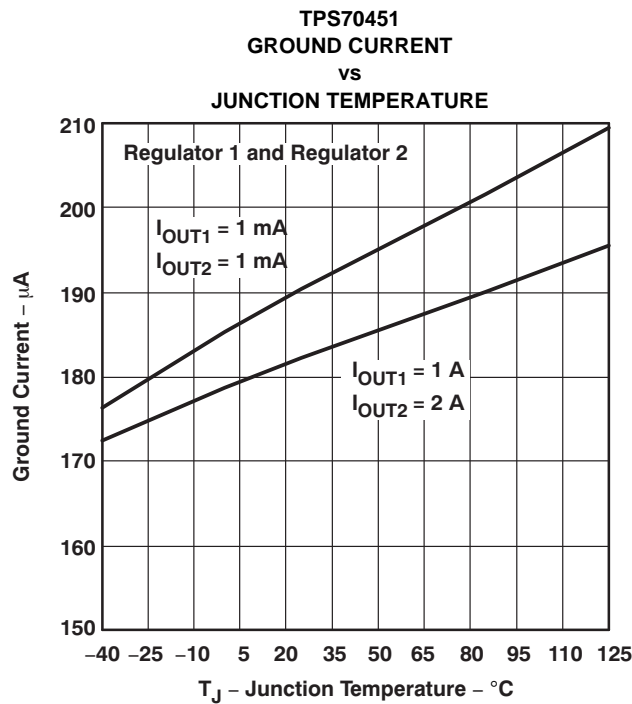

Figure 5.

TYPICAL CHARACTERISTICS (continued)

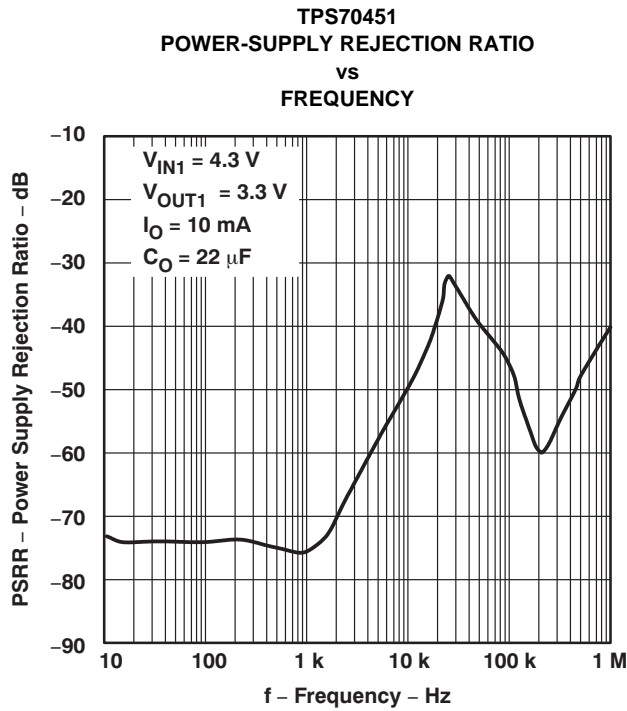

Figure 6.

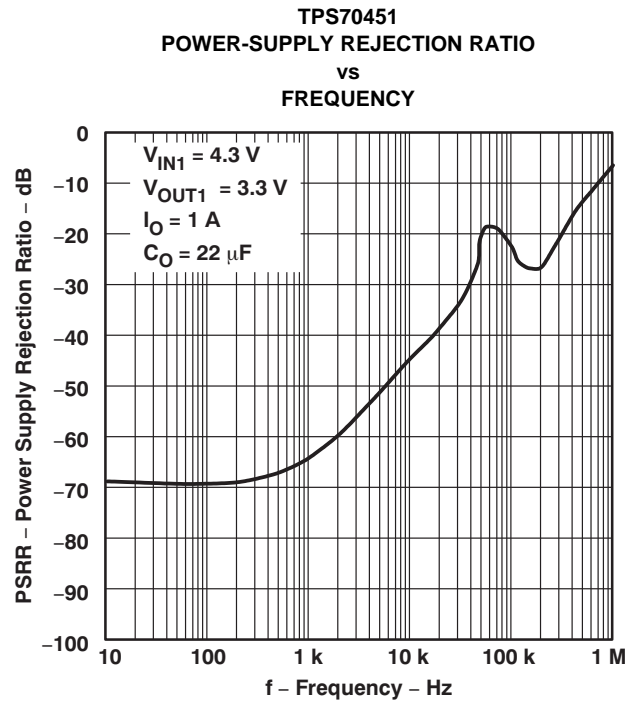

Figure 7.

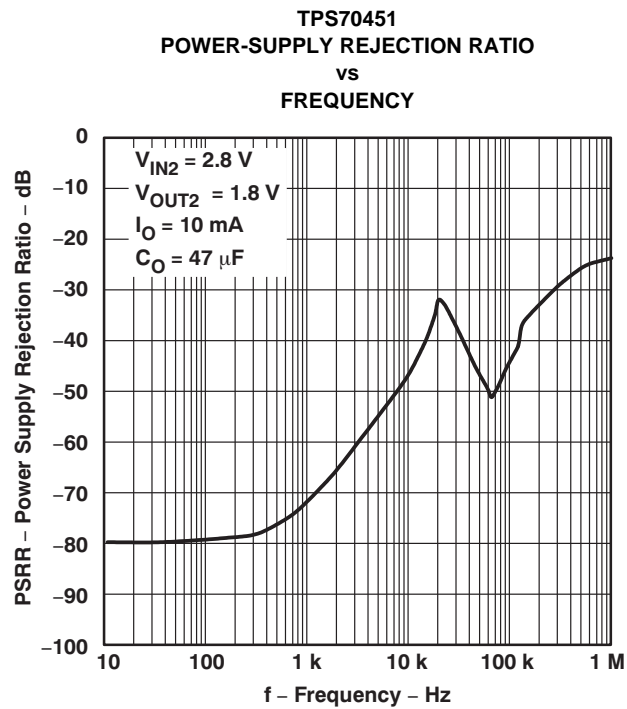

Figure 8.

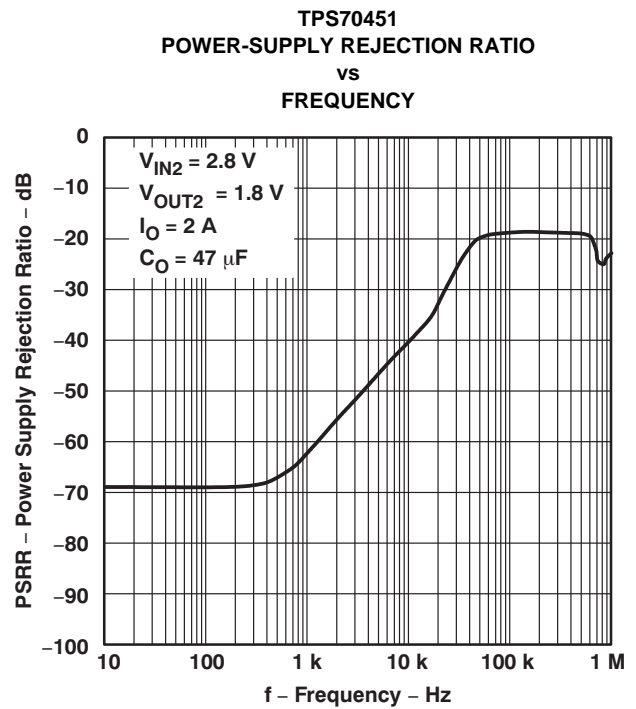

Figure 9.

TYPICAL CHARACTERISTICS (continued)

**OUTPUT SPECTRAL NOISE DENSITY
 vs
 FREQUENCY**

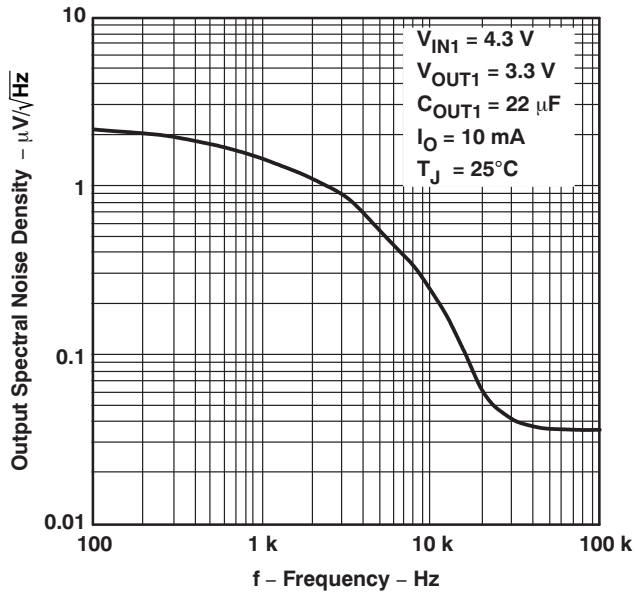

Figure 10.

**OUTPUT SPECTRAL NOISE DENSITY
 vs
 FREQUENCY**

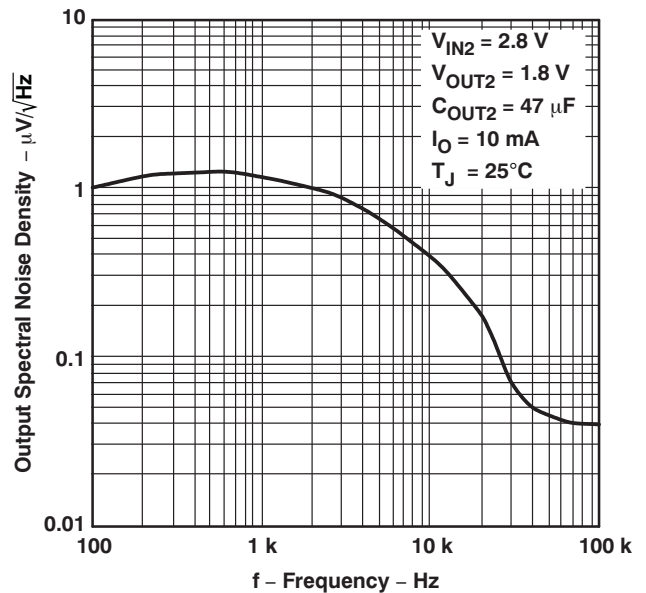

Figure 11.

**OUTPUT SPECTRAL NOISE DENSITY
 vs
 FREQUENCY**

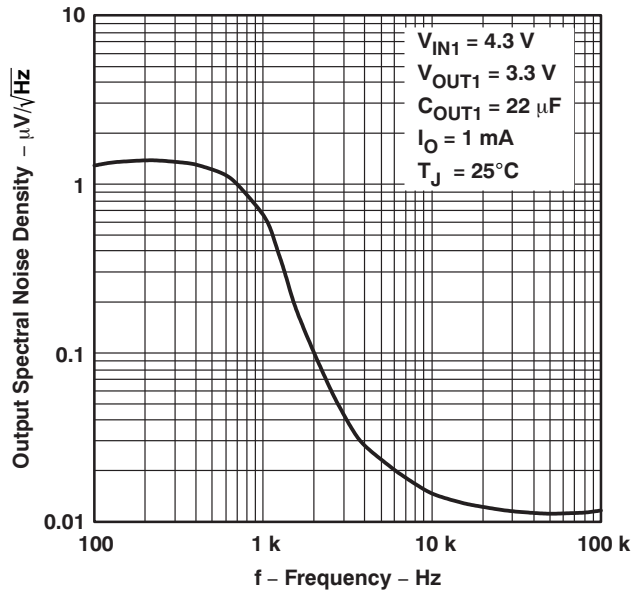

Figure 12.

**OUTPUT SPECTRAL NOISE DENSITY
 vs
 FREQUENCY**

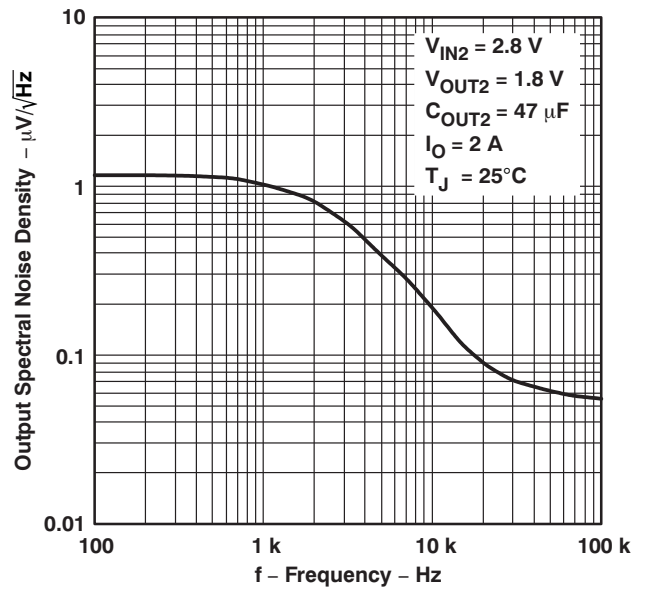

Figure 13.

TYPICAL CHARACTERISTICS (continued)

OUTPUT IMPEDANCE
vs
FREQUENCY

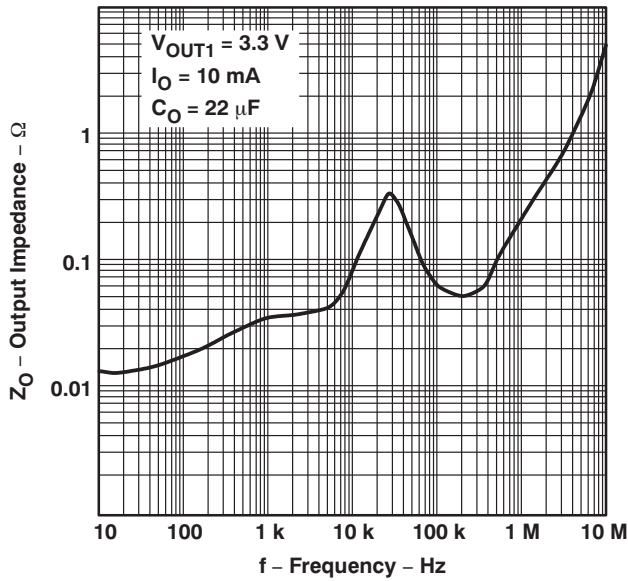

Figure 14.

OUTPUT IMPEDANCE
vs
FREQUENCY

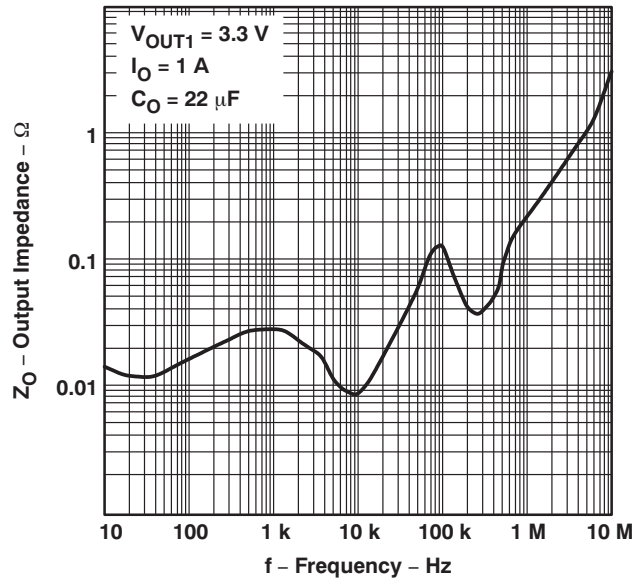

Figure 15.

OUTPUT IMPEDANCE
vs
FREQUENCY

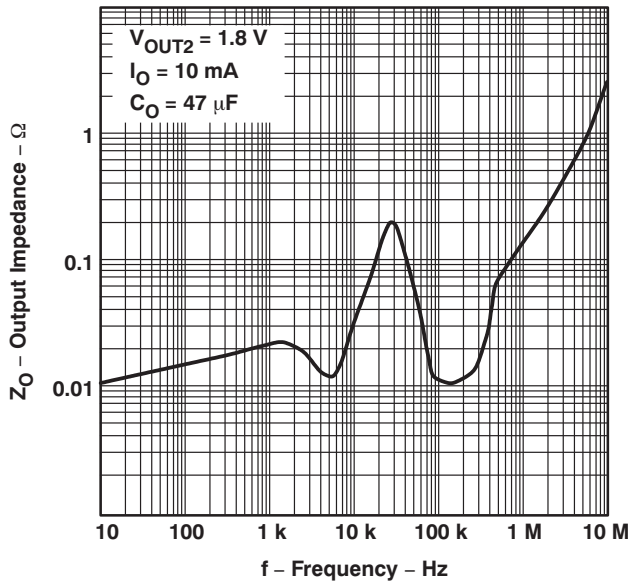

Figure 16.

OUTPUT IMPEDANCE
vs
FREQUENCY

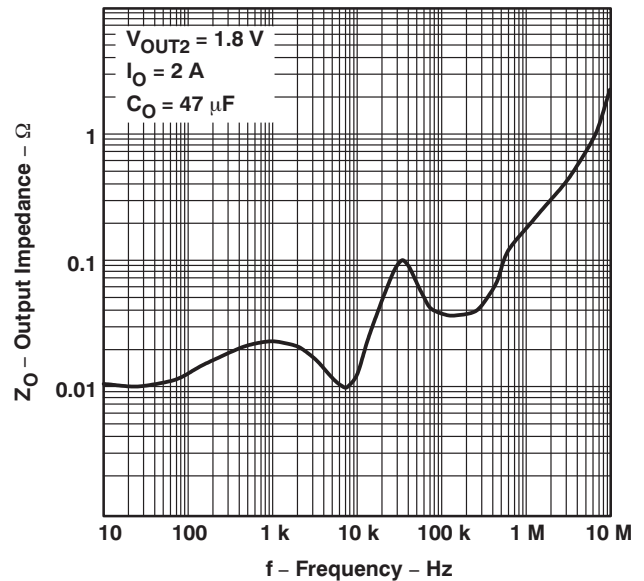

Figure 17.

TYPICAL CHARACTERISTICS (continued)

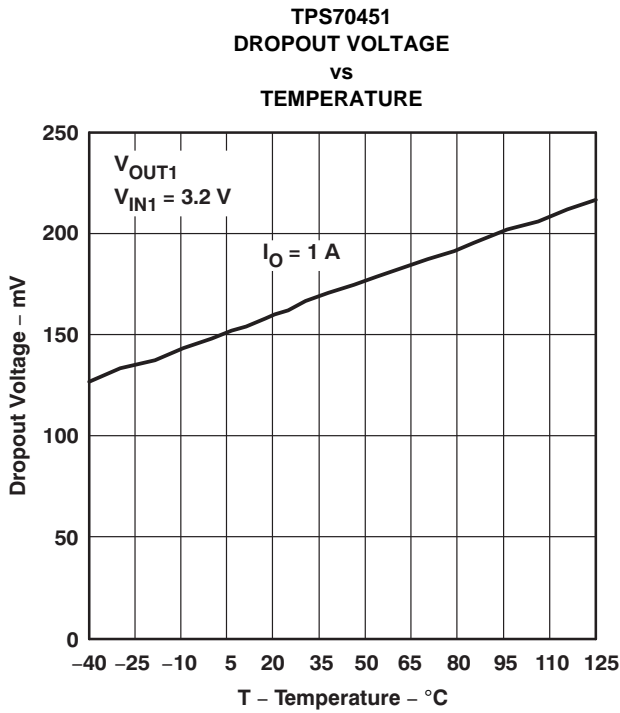

Figure 18.

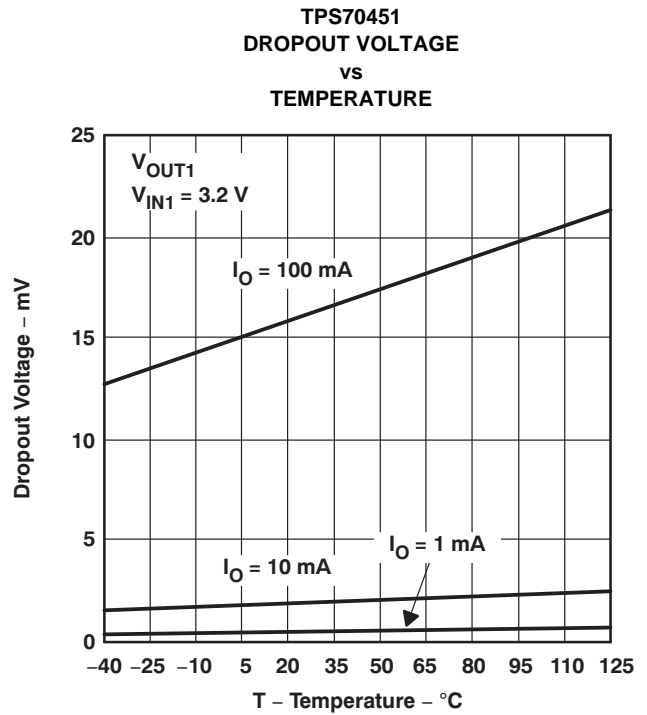

Figure 19.

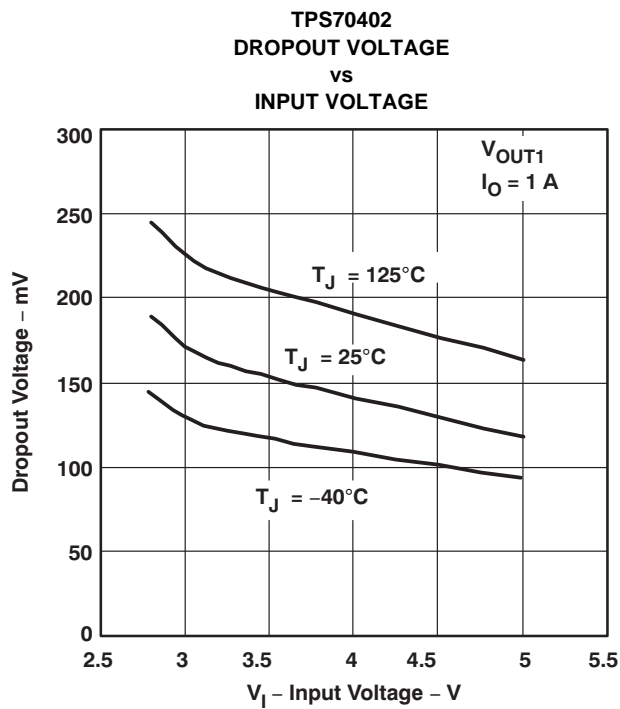

Figure 20.

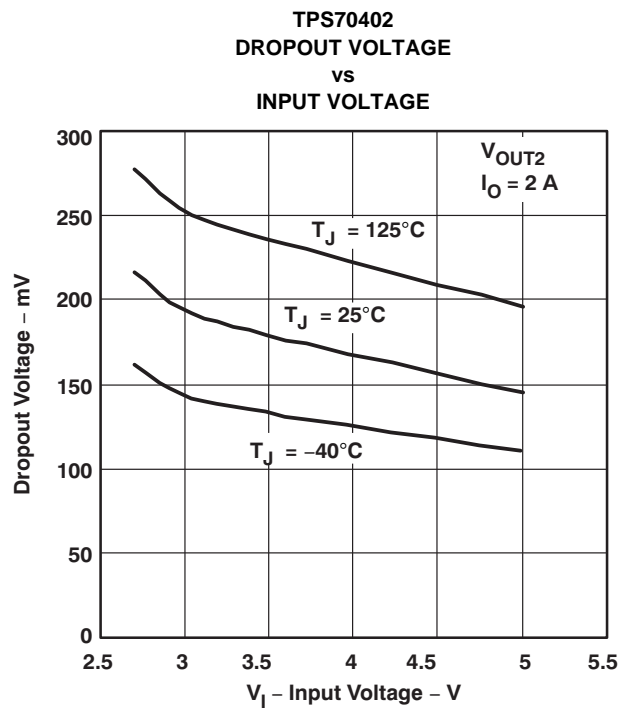

Figure 21.

TYPICAL CHARACTERISTICS (continued)

LOAD TRANSIENT RESPONSE

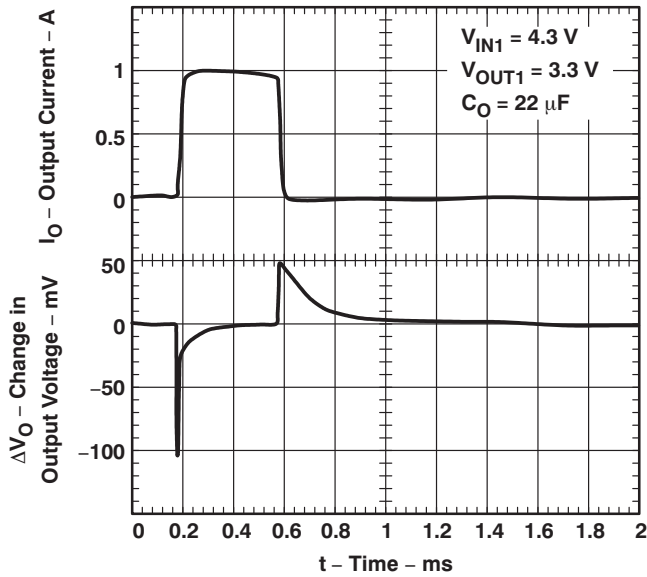

Figure 22.

LOAD TRANSIENT RESPONSE

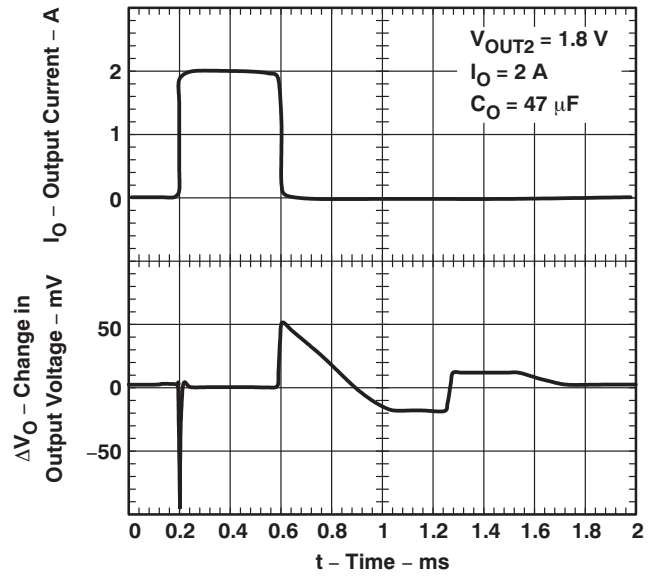

Figure 23.

LINE TRANSIENT RESPONSE

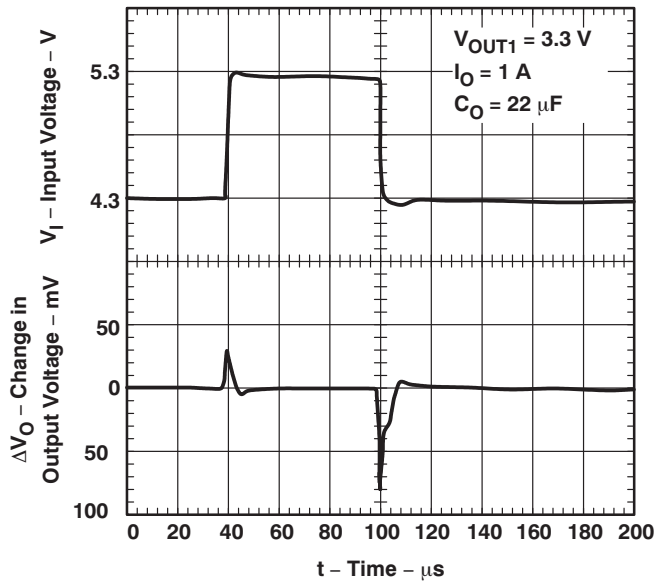

Figure 24.

LINE TRANSIENT RESPONSE

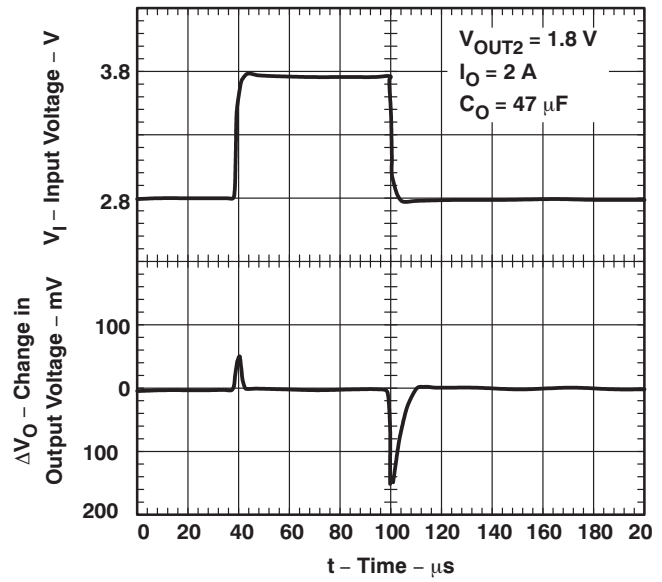

Figure 25.

TYPICAL CHARACTERISTICS (continued)

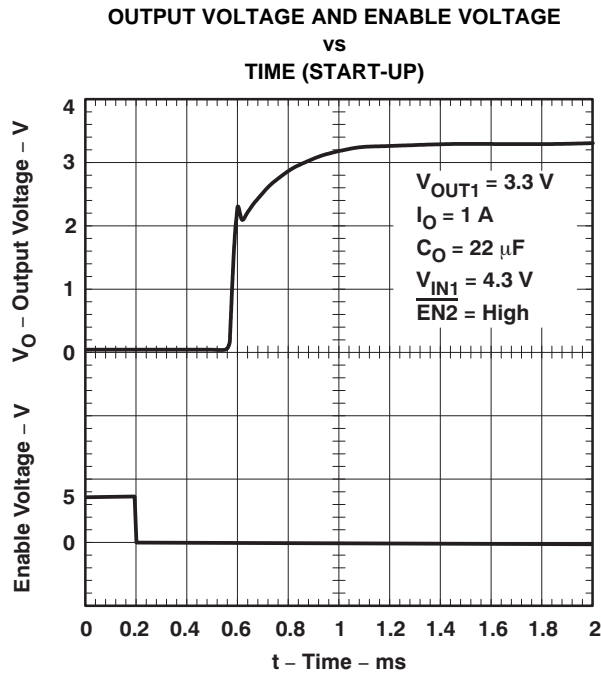

Figure 26.

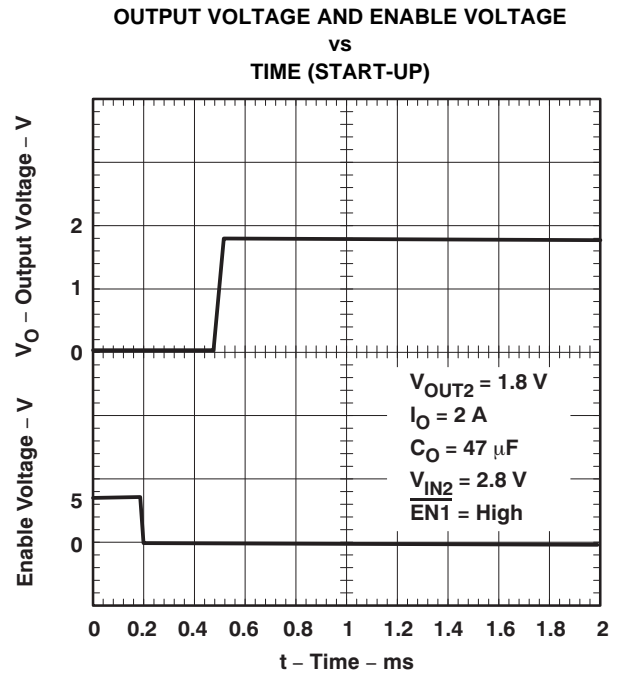

Figure 27.

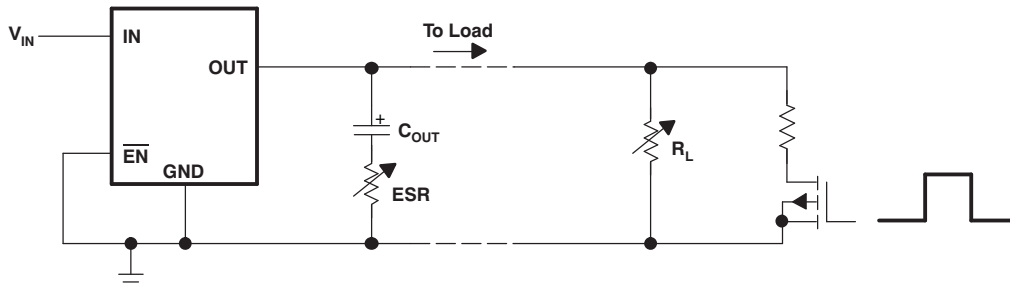

Figure 28. Test Circuit for Typical Regions of Stability

TYPICAL CHARACTERISTICS (continued)

TYPICAL REGION OF STABILITY
EQUIVALENT SERIES RESISTANCE⁽¹⁾

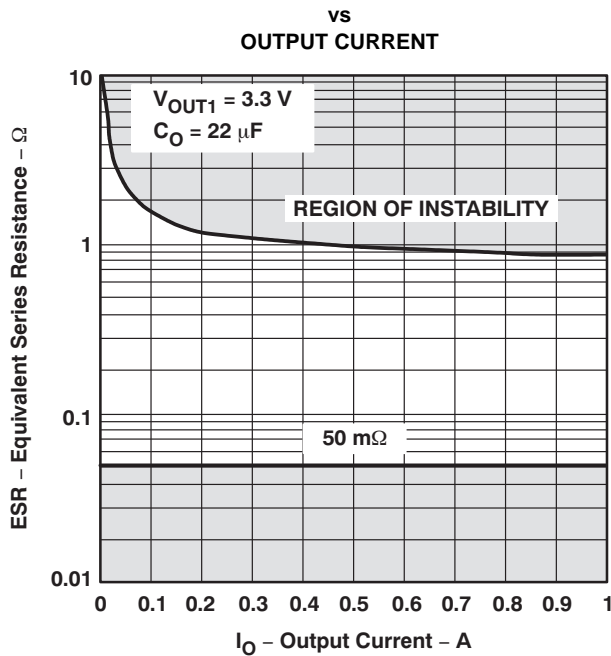

Figure 29.

TYPICAL REGION OF STABILITY
EQUIVALENT SERIES RESISTANCE⁽¹⁾

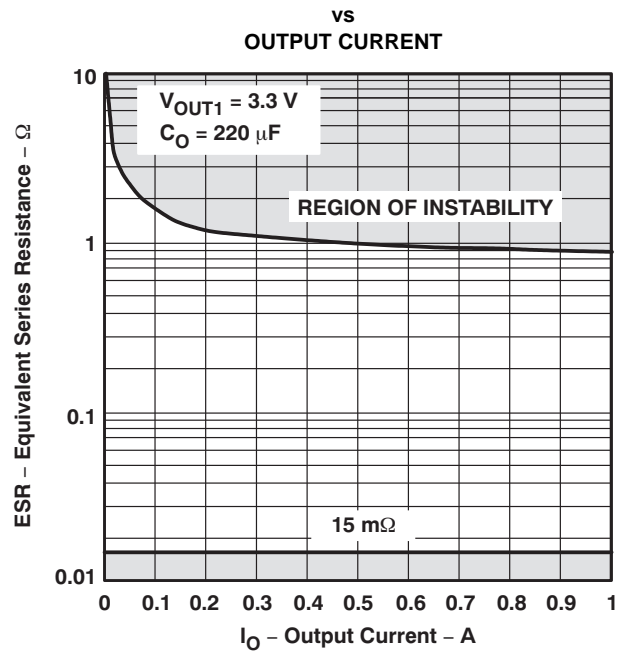

Figure 30.

TYPICAL REGION OF STABILITY
EQUIVALENT SERIES RESISTANCE⁽¹⁾

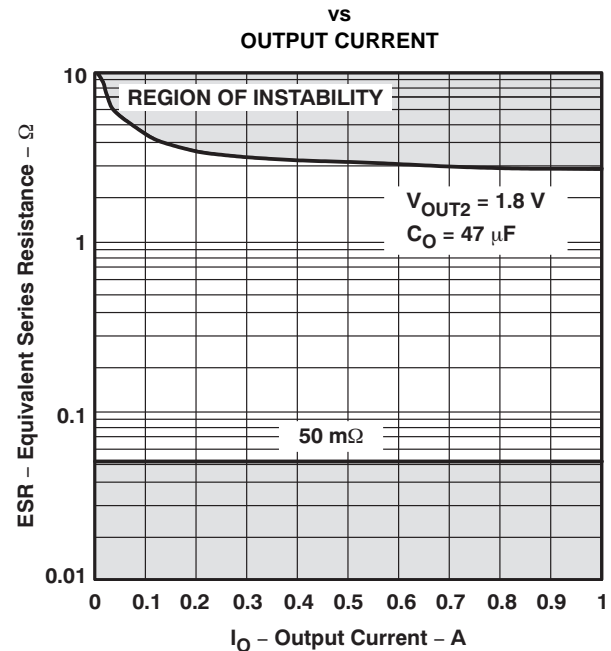

Figure 31.

TYPICAL REGION OF STABILITY
EQUIVALENT SERIES RESISTANCE⁽¹⁾

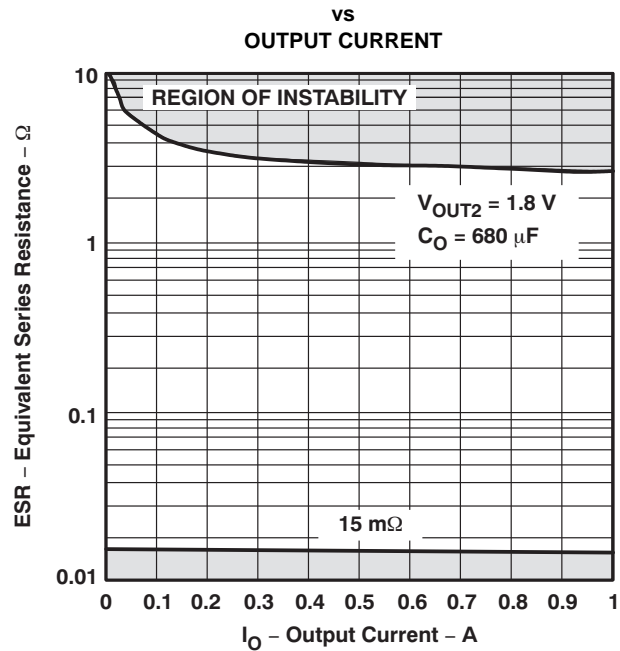

Figure 32.

⁽¹⁾ Equivalent series resistance (ESR) refers to the total series resistance, including the ESR of the capacitor, any series resistance added externally, and PWB trace resistance to C_O .

THERMAL INFORMATION

Thermally-Enhanced TSSOP-24 (PWP— PowerPAD™)

The thermally-enhanced PWP package is based on the 24-pin TSSOP, but includes a thermal pad [see [Figure 33\(c\)](#)] to provide an effective thermal contact between the IC and the printed wiring board (PWB).

Traditionally, surface mount and power have been mutually exclusive terms. A variety of scaled-down TO220-type packages have leads formed as gull wings to make them applicable for surface-mount applications. These packages, however, suffer from several shortcomings: they do not address the very low profile requirements (<2 mm) of many of today's advanced systems, and they do not offer a pin-count high enough to accommodate increasing integration. On the other hand, traditional low-power surface-mount packages require power-dissipation derating that severely limits the usable range of many high-performance analog circuits.

The PWP package (thermally-enhanced TSSOP) combines fine-pitch surface-mount technology with thermal performance comparable to much larger power packages.

The PWP package is designed to optimize the heat transfer to the PWB. Because of the very small size and limited mass of a TSSOP package, thermal enhancement is achieved by improving the thermal conduction paths that remove heat from the component. The thermal pad is formed using a lead-frame design (patent pending) and manufacturing technique to provide the user with direct connection to the heat-generating IC. When this pad is soldered or otherwise coupled to an external heat dissipator, high power dissipation in the ultrathin, fine-pitch, surface-mount package can be reliably achieved.

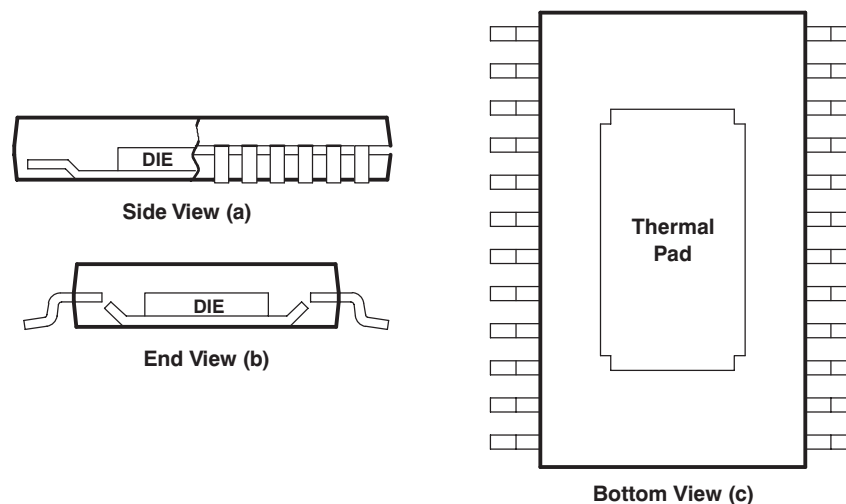

Figure 33. Views of Thermally-Enhanced PWP Package

Because the conduction path has been enhanced, power-dissipation capability is determined by the thermal considerations in the PWB design. For example, simply adding a localized copper plane (heat-sink surface), which is coupled to the thermal pad, enables the PWP package to dissipate 2.5 W in free air (reference [Figure 35\(a\)](#), 8 cm² of copper heat sink and natural convection). Increasing the heat-sink size increases the power dissipation range for the component. The power dissipation limit can be further improved by adding airflow to a PWB/IC assembly (see [Figure 34](#) and [Figure 35](#)). The line drawn at 0.3 cm² in [Figure 34](#) and [Figure 35](#) indicates performance at the minimum recommended heat-sink size, illustrated in [Figure 36](#).

The thermal pad is directly connected to the substrate of the IC, which for the TPS704xx series is a secondary electrical connection to device ground. The heat-sink surface that is added to the PWP can be a ground plane or left electrically isolated. In TO220-type surface-mount packages, the thermal connection is also the primary electrical connection for a given terminal which is not always ground. The PWP package provides up to 24 independent leads that can be used as inputs and outputs (**Note:** leads 1, 12, 13, and 24 are internally connected to the thermal pad and the IC substrate).

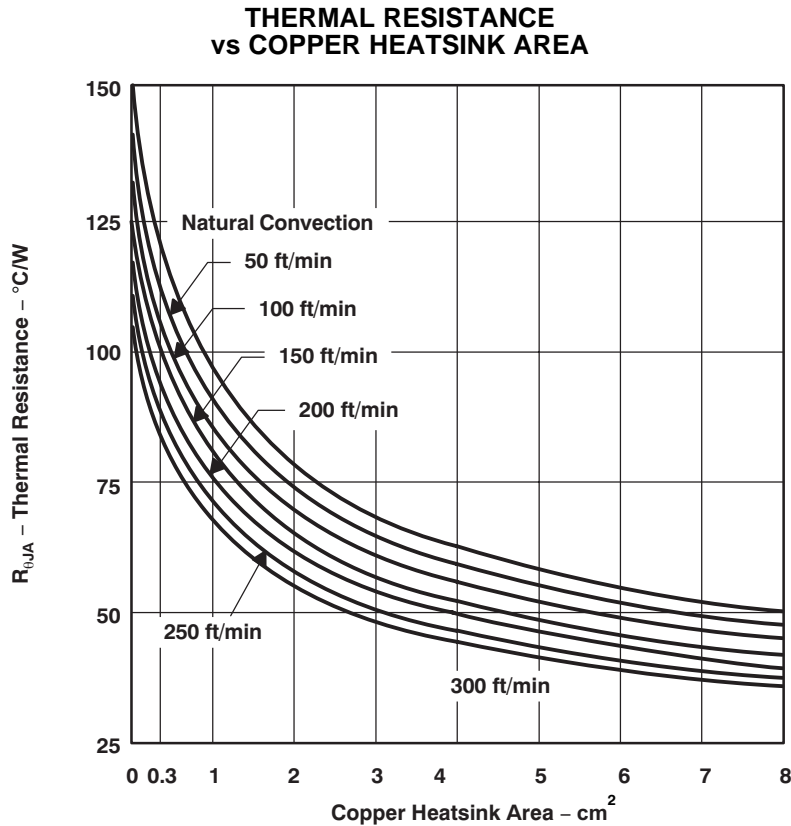
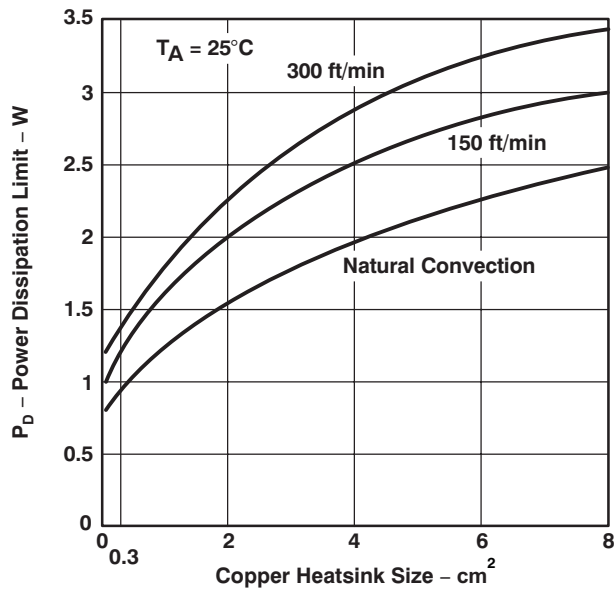
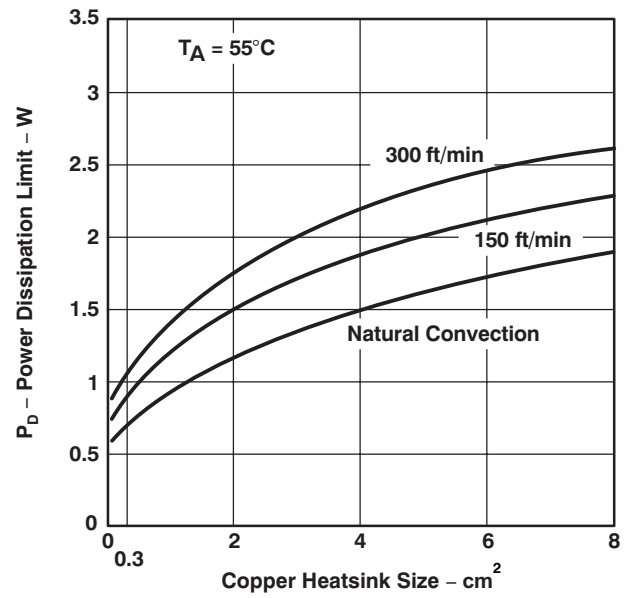

Figure 34.



(a)



(b)

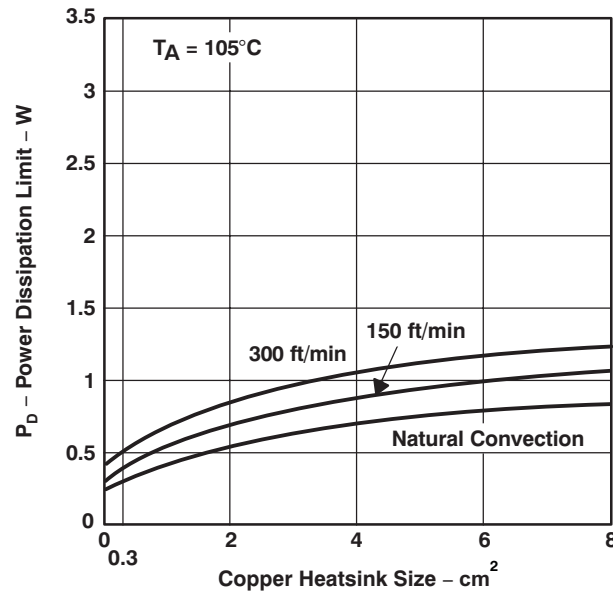

(c)

Figure 35. Power Ratings of the PWP Package at Ambient Temperatures of +25°C, +55°C, and +105°C

Figure 36 is an example of a thermally-enhanced PWB layout for use with the new PWP package. This board configuration was used in the thermal experiments that generated the power ratings shown in Figure 34 and Figure 35. As discussed earlier, copper has been added on the PWB to conduct heat away from the device. $R_{\theta JA}$ for this assembly is illustrated in Figure 34 as a function of heat-sink area. A family of curves is included to illustrate the effect of airflow introduced into the system.

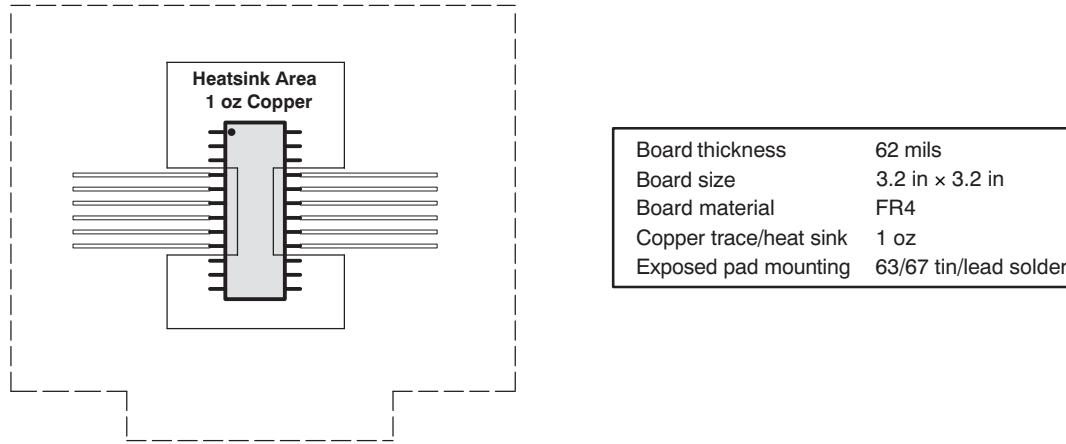

Figure 36. PWB Layout (Including Copper Heatsink Area) for Thermally-Enhanced PWP Package

From Figure 34, $R_{\theta JA}$ for a PWB assembly can be determined and used to calculate the maximum power-dissipation limit for the component/PWB assembly, with the equation:

$$P_{D(max)} = \frac{T_{Jmax} - T_A}{R_{\theta JA(system)}}$$

where:

- T_{Jmax} is the maximum specified junction temperature (+150°C absolute maximum limit, +125°C recommended operating limit) and T_A is the ambient temperature. (1)

$P_{D(max)}$ should then be applied to the internal power dissipated by the TPS704xx regulator. The equation for calculating total internal power dissipation of the TPS704xx is:

$$P_{D(total)} = (V_{IN1} - V_{OUT1}) \times I_{OUT1} + V_{IN1} \times \frac{I_Q}{2} + (V_{IN2} - V_{OUT2}) \times I_{OUT2} + V_{IN2} \times \frac{I_Q}{2} \quad (2)$$

Since the quiescent current of the TPS704xx is very low, the second term is negligible, further simplifying the equation to:

$$P_{D(total)} = (V_{IN1} - V_{OUT1}) \times I_{OUT1} + (V_{IN2} - V_{OUT2}) \times I_{OUT2} \quad (3)$$

For the case where $T_A = +55^\circ\text{C}$, airflow = 200 ft/min, copper heat-sink area = 4 cm², the maximum power-dissipation limit can be calculated. First, from Figure 34, we find the system $R_{\theta JA}$ is +50°C/W; therefore, the maximum power-dissipation limit is:

$$P_{D(max)} = \frac{T_{Jmax} - T_A}{R_{\theta JA(system)}} = \frac{+125^\circ\text{C} - 55^\circ\text{C}}{+50^\circ\text{C/W}} = 1.4 \text{ W} \quad (4)$$

If the system implements a TPS704xx regulator, where $V_{IN1} = 5.0\text{V}$, $V_{IN2} = 2.8 \text{ V}$, $I_{OUT1} = 500 \text{ mA}$, and $I_{OUT2} = 800 \text{ mA}$, the internal power dissipation is:

$$\begin{aligned} P_{D(total)} &= (V_{IN1} - V_{OUT1}) \times I_{OUT1} + (V_{IN2} - V_{OUT2}) \times I_{OUT2} \\ &= (5.0 - 3.3) \times 0.5 + (2.8 - 1.8) \times 0.8 = 1.25 \text{ W} \end{aligned} \quad (5)$$

Comparing $P_{D(\text{total})}$ with $P_{D(\text{max})}$ reveals that the power dissipation in this example does not exceed the calculated limit. When it does, one of two corrective actions should be made: raising the power-dissipation limit by increasing the airflow or the heat-sink area, or lowering the internal power dissipation of the regulator by reducing the input voltage or the load current. In either case, the above calculations should be repeated with the new system parameters. This parameter is measured with the recommended copper heat sink pattern on a 4-layer PWB, 2 oz. copper traces on 4-in x 4-in ground layer. Simultaneous and continuous operation of both regulator outputs at full load may exceed the power dissipation rating of the PWP package.

Mounting Information

The primary requirement is to complete the thermal contact between the thermal pad and the PWB metal. The thermal pad is a solderable surface and is fully intended to be soldered at the time the component is mounted. Although voiding in the thermal-pad solder-connection is not desirable, up to 50% voiding is acceptable. The data included in [Figure 34](#) and [Figure 36](#) are for soldered connections with voiding between 20% and 50%. The thermal analysis shows no significant difference resulting from the variation in voiding percentage.

[Figure 37](#) shows the solder-mask land pattern for the PWP package. The minimum recommended heat-sink area is also illustrated. This is simply a copper plane under the body extent of the package, including metal routed under terminals 1, 12, 13, and 24.

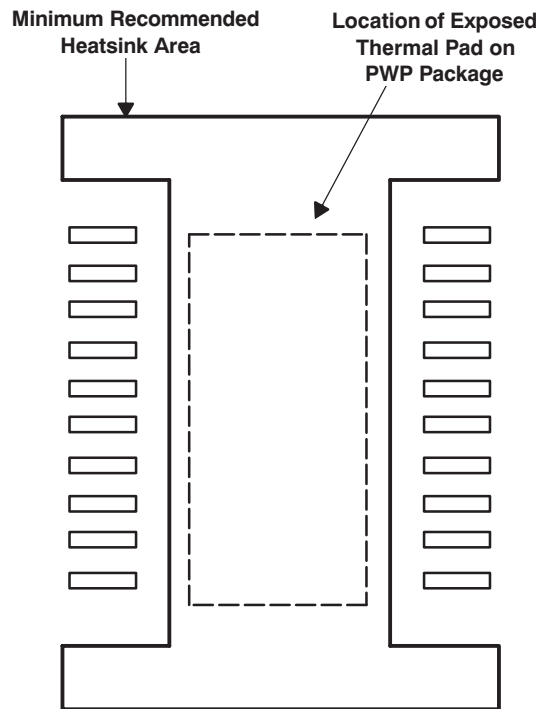

Figure 37. PWP Package Land Pattern

APPLICATION INFORMATION

Sequencing Timing Diagrams

This section provides a number of timing diagrams showing how this device functions in different configurations.

Application condition: V_{IN1} and V_{IN2} are tied to the same fixed input voltage greater than V_{UVLO} . PG2 is tied to \overline{MR} .

$\overline{EN1}$ and $\overline{EN2}$ are initially high; therefore, both regulators are off, and PG1 and PG2 (tied to \overline{MR}) are at logic low. Since \overline{MR} is at logic low, \overline{RESET} is also at logic low. When $\overline{EN1}$ is taken to logic low, V_{OUT1} turns on. Later, when $\overline{EN2}$ is taken to logic low, V_{OUT2} turns on. When V_{OUT1} reaches 95% of its regulated output voltage, PG1 goes to logic high. When V_{OUT2} reaches 95% of its regulated output voltage, PG2 (tied to \overline{MR}) goes to logic high. When V_{IN1} is greater than V_{UVLO} and \overline{MR} (tied to PG2) is at logic high, \overline{RESET} is pulled to logic high after a 120-ms delay. When $\overline{EN1}$ and $\overline{EN2}$ are returned to logic high, both devices power down and both PG1, PG2 (tied to \overline{MR}), and \overline{RESET} return to logic low.

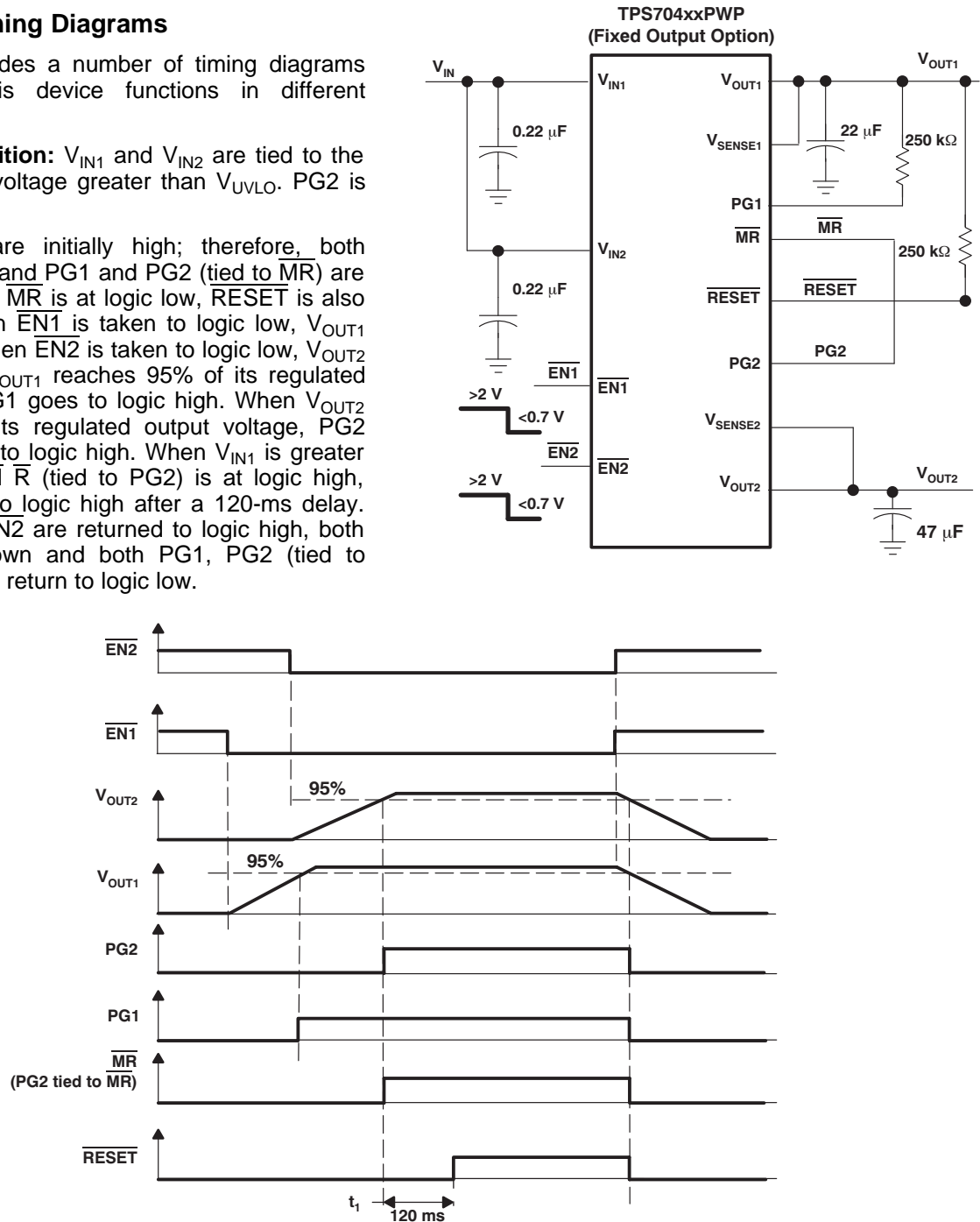

NOTES: A. t_1 : Time at which V_{IN} is greater than V_{UVLO} and \overline{MR} is logic high.
B. The timing diagram is not drawn to scale.

Figure 38. Timing When V_{OUT1} Is Enabled Before V_{OUT2}

Application condition: V_{IN1} and V_{IN2} are tied to the same fixed input voltage greater than V_{UVLO} . \overline{MR} is initially logic high but is eventually toggled.

$\overline{EN1}$ and $\overline{EN2}$ are initially high; therefore, both regulators are off, and PG1 and PG2 are at logic low. Since V_{IN1} is greater than V_{UVLO} and \overline{MR} is at logic high, \overline{RESET} is also at logic high. When $\overline{EN2}$ is taken to logic low, V_{OUT2} turns on. Later, when $\overline{EN1}$ is taken to logic low, V_{OUT1} turns on. When V_{OUT2} reaches 95% of its regulated output voltage, PG2 goes to logic high. When V_{OUT1} reaches 95% of its regulated output voltage, PG1 goes to logic high. When \overline{MR} is taken to logic low, \overline{RESET} is taken low. When \overline{MR} returns to logic high, \overline{RESET} returns to logic high after a 120-ms delay.

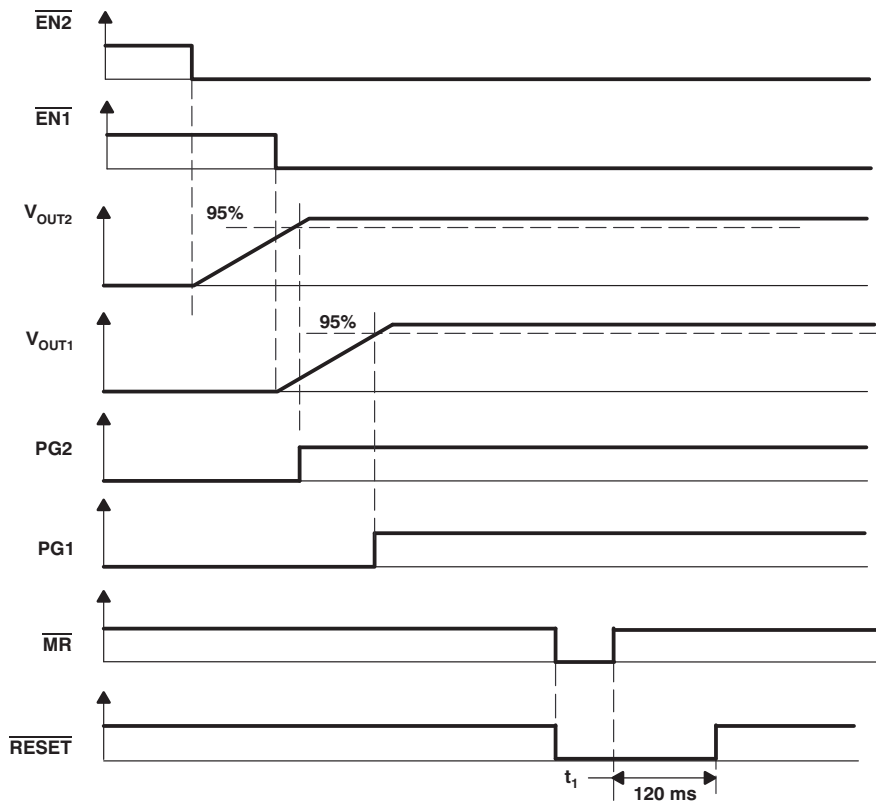
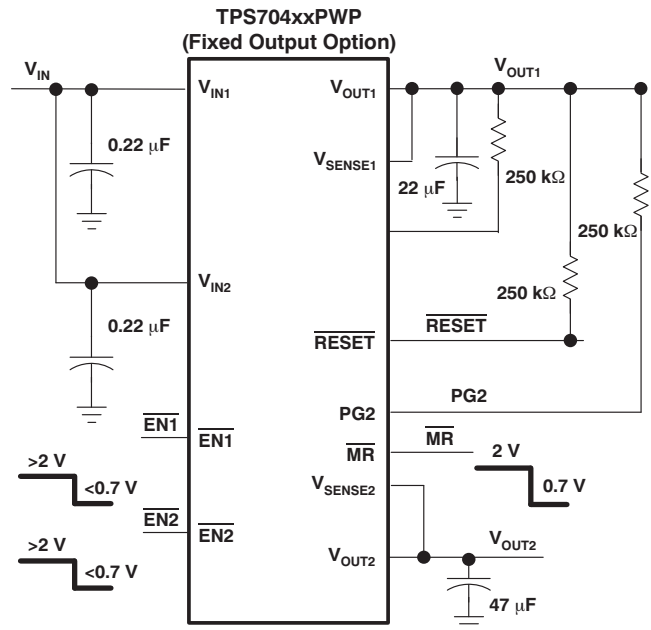

NOTES: A. t_1 : Time at which V_{IN} is greater than V_{UVLO} and \overline{MR} is logic high.
 B. The timing diagram is not drawn to scale.

Figure 39. Timing When \overline{MR} is Toggled

Application condition: V_{IN1} and V_{IN2} are tied to same fixed input voltage greater than V_{UVLO} . $\overline{PG1}$ is tied to \overline{MR} .

$\overline{EN1}$ and $\overline{EN2}$ are initially high; therefore, both regulators are off, and $\overline{PG1}$ (tied to \overline{MR}) and $\overline{PG2}$ are at logic low. Since \overline{MR} is at logic low, \overline{RESET} is also at logic low. When $\overline{EN2}$ is taken to logic low, V_{OUT2} turns on. Later, when $\overline{EN1}$ is taken to logic low, V_{OUT1} turns on. When V_{OUT2} reaches 95% of its regulated output voltage, $\overline{PG2}$ goes to logic high. When V_{OUT1} reaches 95% of its regulated output voltage, $\overline{PG1}$ goes to logic high. When V_{IN1} is greater than V_{UVLO} and \overline{MR} (tied to $\overline{PG2}$) is at logic high, \overline{RESET} is pulled to logic high after a 120-ms delay. When a fault on V_{OUT1} causes it to fall below 95% of its regulated output voltage, $\overline{PG1}$ (tied to \overline{MR}) goes to logic low. Since \overline{MR} is logic low, \overline{RESET} goes to logic low. V_{OUT2} is unaffected.

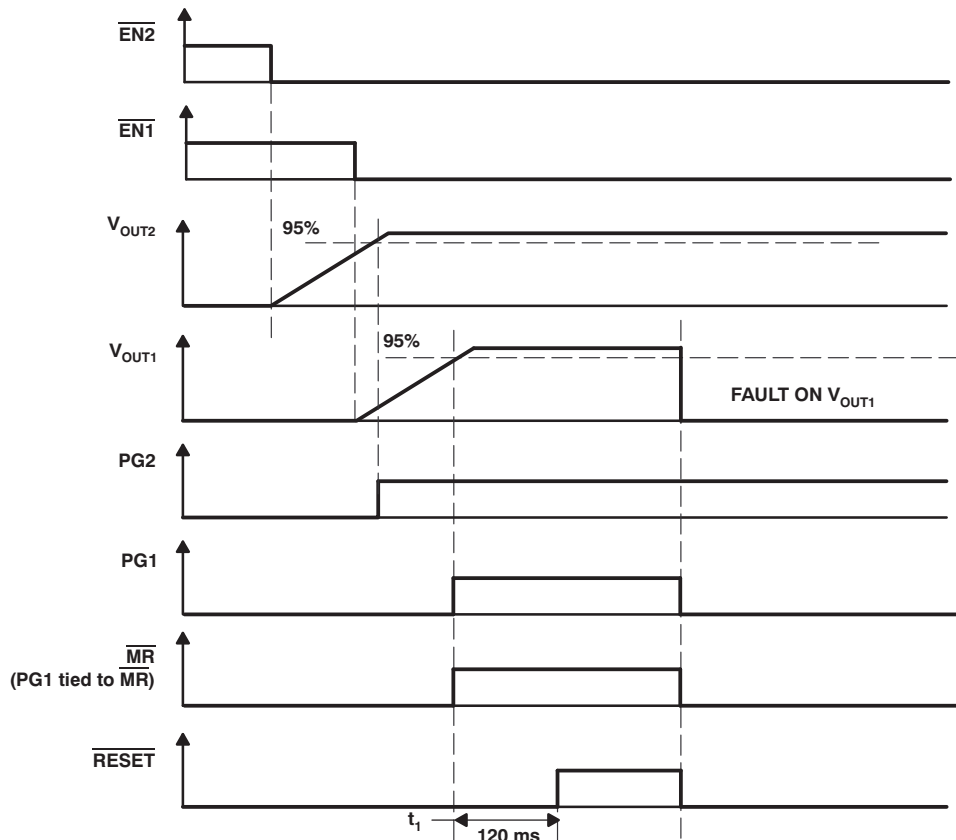
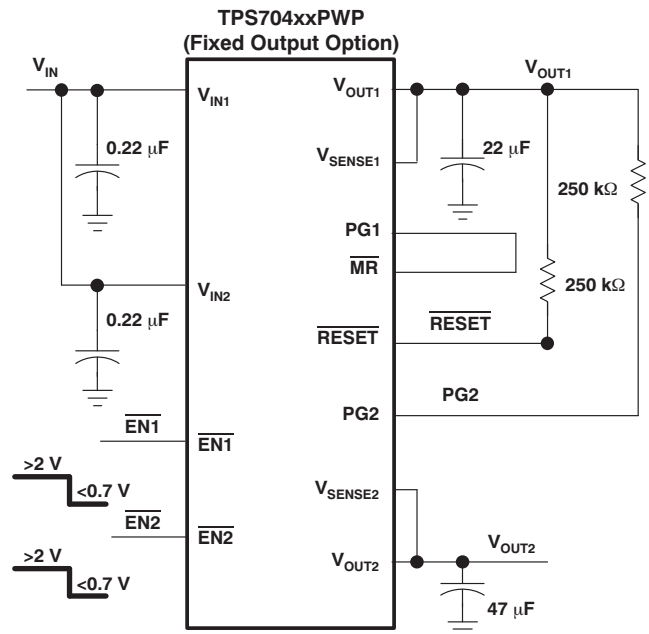

NOTES: A. t_1 : Time at which V_{IN} is greater than V_{UVLO} and \overline{MR} is logic high.
B. The timing diagram is not drawn to scale.

Figure 40. Timing When There is a Fault on V_{OUT1}

APPLICATION INFORMATION

Input Capacitor

For a typical application, a ceramic input bypass capacitor (0.22 μF to 1 μF) is recommended. This capacitor should be as close to the input pins as possible. Due to the impedance of the input supply, large transient currents cause the input voltage to droop. If this droop causes the input voltage to drop below the UVLO threshold, the device turns off. Therefore, it is recommended to place a larger capacitor in parallel with the ceramic bypass capacitor at the regulator input. The size of this capacitor depends on the output current, the response time of the main power supply, and the main power supply distance to the regulator. At a minimum, the capacitor should be sized to ensure that the input voltage does not drop below the minimum UVLO threshold voltage during normal operating conditions.

Output Capacitor

As with most LDO regulators, the TPS704xx requires an output capacitor connected between OUT and GND to stabilize the internal control loop. The minimum recommended capacitance value for $V_{\text{OUT}1}$ is 22 μF and the ESR (equivalent series resistance) must be between 50 m Ω and 800 m Ω . The minimum recommended capacitance value for $V_{\text{OUT}2}$ is 47 μF and the ESR must be between 50 m Ω and 2 Ω . Solid tantalum electrolytic, aluminum electrolytic, and multilayer ceramic capacitors are all suitable, provided they meet the requirements described above. Larger capacitors provide a wider range of stability and better load transient response. [Table 1](#) gives a partial listing of surface-mount capacitors suitable for use with the TPS704xx for fast transient response applications.

This information, along with the ESR graphs, is included to assist in selection of suitable capacitance for user applications. When necessary to achieve low height requirements along with high output current and/or high load capacitance, several higher ESR capacitors can be used in parallel to meet the guidelines above.

Table 1. Partial Listing of TPS704xx-Compatible Surface-Mount Capacitors

VALUE	MANUFACTURER	MFR PART NO.
680 μF	Kemet	T510X6871004AS
470 μF	Sanyo	4TPB470M
150 μF	Sanyo	4TPC150M
220 μF	Sanyo	2R5TPC220M
100 μF	Sanyo	2R5TPC220M
68 μF	Sanyo	10TPC68M
68 μF	Kemet	T495D6861006AS
47 μF	Kemet	T495D4761010AS
33 μF	Kemet	T495C3361016AS
22 μF	Kemet	T495C2261010AS

Programming the TPS70402 Adjustable LDO Regulator

The output voltage of the TPS70402 adjustable regulators is programmed using external resistor dividers as shown in Figure 41.

Resistors R1 and R2 should be chosen for approximately a 50- μ A divider current. Lower value resistors can be used, but offer no inherent advantage and waste more power. Higher values should be avoided as leakage currents at the sense terminal increase the output voltage error. The recommended design procedure is to choose R2 = 30.1 k Ω to set the divider current at approximately 50 μ A, and then calculate R1 using Equation 6:

$$R1 = \left(\frac{V_{OUT}}{V_{REF}} - 1 \right) \times R2 \quad (6)$$

where:

- $V_{REF} = 1.224$ V typ (the internal reference voltage)

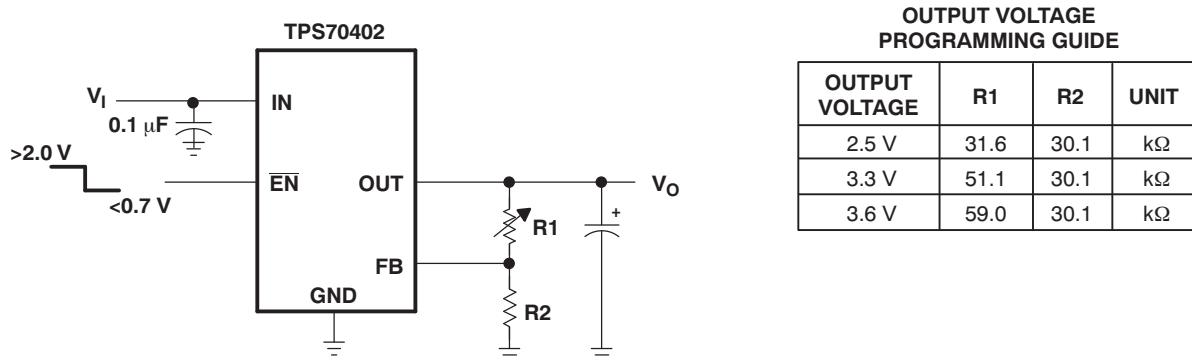

Figure 41. TPS70402 Adjustable LDO Regulator Programming

Regulator Protection

Both TPS704xx PMOS-pass transistors have built-in back diodes that conduct reverse currents when the input voltage drops below the output voltage (for example, during power-down). Current is conducted from the output to the input and is not internally limited. When extended reverse voltage is anticipated, external limiting may be appropriate.

The TPS704xx also features internal current limiting and thermal protection. During normal operation, the TPS704xx regulator 1 limits output current to approximately 1.75 A (typ) and regulator 2 limits output current to approximately 3.8 A (typ). When current limiting engages, the output voltage scales back linearly until the overcurrent condition ends. While current limiting is designed to prevent gross device failure, care should be taken not to exceed the power dissipation ratings of the package. If the temperature of the device exceeds +150°C (typ), thermal-protection circuitry shuts it down. Once the device has cooled below +130°C (typ), regulator operation resumes.

REVISION HISTORY

NOTE: Page numbers for previous revisions may differ from page numbers in the current version.

Changes from Revision E (February 2010) to Revision F Page

- Changed *Tube* transport media, quatity values from 70 to 60 in Ordering Information table 3
-

Changes from Revision D (December, 2007) to Revision E Page

- Corrected pin description for pin 21 in pinout drawing 1
 - Updated *Dissipation Ratings* table values 4
 - Deleted *falling edge delay* specification 6
 - Updated *Fixed Voltage Version* block diagram 7
 - Updated *Adjustable Voltage Version* block diagram 8
-

PACKAGING INFORMATION

Orderable Device	Status ⁽¹⁾	Package Type	Package Drawing	Pins	Package Qty	Eco Plan ⁽²⁾	Lead/Ball Finish	MSL Peak Temp ⁽³⁾
TPS70402PWP	ACTIVE	HTSSOP	PWP	24	60	Green (RoHS & no Sb/Br)	CU NIPDAU	Level-2-260C-1 YEAR
TPS70402PWPG4	ACTIVE	HTSSOP	PWP	24	60	Green (RoHS & no Sb/Br)	CU NIPDAU	Level-2-260C-1 YEAR
TPS70402PWPR	ACTIVE	HTSSOP	PWP	24	2000	Green (RoHS & no Sb/Br)	CU NIPDAU	Level-2-260C-1 YEAR
TPS70402PWPRG4	ACTIVE	HTSSOP	PWP	24	2000	Green (RoHS & no Sb/Br)	CU NIPDAU	Level-2-260C-1 YEAR
TPS70445PWP	ACTIVE	HTSSOP	PWP	24	60	Green (RoHS & no Sb/Br)	CU NIPDAU	Level-2-260C-1 YEAR
TPS70445PWPG4	ACTIVE	HTSSOP	PWP	24	60	Green (RoHS & no Sb/Br)	CU NIPDAU	Level-2-260C-1 YEAR
TPS70445PWPR	ACTIVE	HTSSOP	PWP	24	2000	Green (RoHS & no Sb/Br)	CU NIPDAU	Level-2-260C-1 YEAR
TPS70445PWPRG4	ACTIVE	HTSSOP	PWP	24	2000	Green (RoHS & no Sb/Br)	CU NIPDAU	Level-2-260C-1 YEAR
TPS70448PWP	ACTIVE	HTSSOP	PWP	24	60	Green (RoHS & no Sb/Br)	CU NIPDAU	Level-2-260C-1 YEAR
TPS70448PWPG4	ACTIVE	HTSSOP	PWP	24	60	Green (RoHS & no Sb/Br)	CU NIPDAU	Level-2-260C-1 YEAR
TPS70448PWPR	ACTIVE	HTSSOP	PWP	24	2000	Green (RoHS & no Sb/Br)	CU NIPDAU	Level-2-260C-1 YEAR
TPS70448PWPRG4	ACTIVE	HTSSOP	PWP	24	2000	Green (RoHS & no Sb/Br)	CU NIPDAU	Level-2-260C-1 YEAR
TPS70451PWP	ACTIVE	HTSSOP	PWP	24	60	Green (RoHS & no Sb/Br)	CU NIPDAU	Level-2-260C-1 YEAR
TPS70451PWPG4	ACTIVE	HTSSOP	PWP	24	60	Green (RoHS & no Sb/Br)	CU NIPDAU	Level-2-260C-1 YEAR
TPS70451PWPR	ACTIVE	HTSSOP	PWP	24	2000	Green (RoHS & no Sb/Br)	CU NIPDAU	Level-2-260C-1 YEAR
TPS70451PWPRG4	ACTIVE	HTSSOP	PWP	24	2000	Green (RoHS & no Sb/Br)	CU NIPDAU	Level-2-260C-1 YEAR
TPS70458PWP	ACTIVE	HTSSOP	PWP	24	60	Green (RoHS & no Sb/Br)	CU NIPDAU	Level-2-260C-1 YEAR
TPS70458PWPG4	ACTIVE	HTSSOP	PWP	24	60	Green (RoHS & no Sb/Br)	CU NIPDAU	Level-2-260C-1 YEAR
TPS70458PWPR	ACTIVE	HTSSOP	PWP	24	2000	Green (RoHS & no Sb/Br)	CU NIPDAU	Level-2-260C-1 YEAR
TPS70458PWPRG4	ACTIVE	HTSSOP	PWP	24	2000	Green (RoHS & no Sb/Br)	CU NIPDAU	Level-2-260C-1 YEAR

⁽¹⁾ The marketing status values are defined as follows:

ACTIVE: Product device recommended for new designs.

LIFEBUY: TI has announced that the device will be discontinued, and a lifetime-buy period is in effect.

NRND: Not recommended for new designs. Device is in production to support existing customers, but TI does not recommend using this part in a new design.

PREVIEW: Device has been announced but is not in production. Samples may or may not be available.

OBsolete: TI has discontinued the production of the device.

⁽²⁾ Eco Plan - The planned eco-friendly classification: Pb-Free (RoHS), Pb-Free (RoHS Exempt), or Green (RoHS & no Sb/Br) - please check <http://www.ti.com/productcontent> for the latest availability information and additional product content details.

TBD: The Pb-Free/Green conversion plan has not been defined.

Pb-Free (RoHS): TI's terms "Lead-Free" or "Pb-Free" mean semiconductor products that are compatible with the current RoHS requirements for all 6 substances, including the requirement that lead not exceed 0.1% by weight in homogeneous materials. Where designed to be soldered at high temperatures, TI Pb-Free products are suitable for use in specified lead-free processes.

Pb-Free (RoHS Exempt): This component has a RoHS exemption for either 1) lead-based flip-chip solder bumps used between the die and package, or 2) lead-based die adhesive used between the die and leadframe. The component is otherwise considered Pb-Free (RoHS compatible) as defined above.

Green (RoHS & no Sb/Br): TI defines "Green" to mean Pb-Free (RoHS compatible), and free of Bromine (Br) and Antimony (Sb) based flame retardants (Br or Sb do not exceed 0.1% by weight in homogeneous material)

⁽³⁾ MSL, Peak Temp. -- The Moisture Sensitivity Level rating according to the JEDEC industry standard classifications, and peak solder temperature.

Important Information and Disclaimer:The information provided on this page represents TI's knowledge and belief as of the date that it is provided. TI bases its knowledge and belief on information provided by third parties, and makes no representation or warranty as to the accuracy of such information. Efforts are underway to better integrate information from third parties. TI has taken and continues to take reasonable steps to provide representative and accurate information but may not have conducted destructive testing or chemical analysis on incoming materials and chemicals. TI and TI suppliers consider certain information to be proprietary, and thus CAS numbers and other limited information may not be available for release.

In no event shall TI's liability arising out of such information exceed the total purchase price of the TI part(s) at issue in this document sold by TI to Customer on an annual basis.

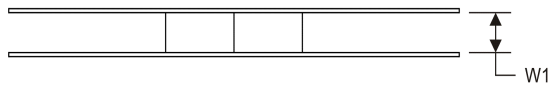
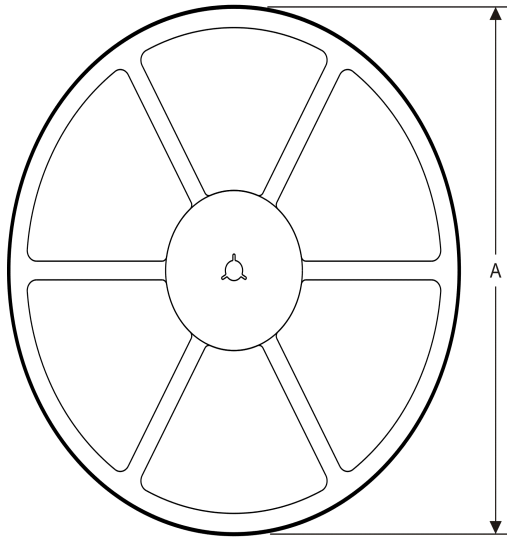
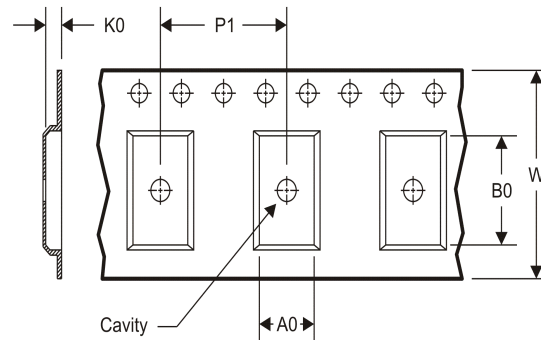
TAPE AND REEL INFORMATION
REEL DIMENSIONS

TAPE DIMENSIONS

A0	Dimension designed to accommodate the component width
B0	Dimension designed to accommodate the component length
K0	Dimension designed to accommodate the component thickness
W	Overall width of the carrier tape
P1	Pitch between successive cavity centers

TAPE AND REEL INFORMATION

*All dimensions are nominal

Device	Package Type	Package Drawing	Pins	SPQ	Reel Diameter (mm)	Reel Width W1 (mm)	A0 (mm)	B0 (mm)	K0 (mm)	P1 (mm)	W (mm)	Pin1 Quadrant
TPS70402PWPR	HTSSOP	PWP	24	2000	330.0	16.4	6.95	8.3	1.6	8.0	16.0	Q1
TPS70445PWPR	HTSSOP	PWP	24	2000	330.0	16.4	6.95	8.3	1.6	8.0	16.0	Q1
TPS70448PWPR	HTSSOP	PWP	24	2000	330.0	16.4	6.95	8.3	1.6	8.0	16.0	Q1
TPS70451PWPR	HTSSOP	PWP	24	2000	330.0	16.4	6.95	8.3	1.6	8.0	16.0	Q1
TPS70458PWPR	HTSSOP	PWP	24	2000	330.0	16.4	6.95	8.3	1.6	8.0	16.0	Q1

TAPE AND REEL BOX DIMENSIONS



*All dimensions are nominal

Device	Package Type	Package Drawing	Pins	SPQ	Length (mm)	Width (mm)	Height (mm)
TPS70402PWPR	HTSSOP	PWP	24	2000	367.0	367.0	38.0
TPS70445PWPR	HTSSOP	PWP	24	2000	367.0	367.0	38.0
TPS70448PWPR	HTSSOP	PWP	24	2000	367.0	367.0	38.0
TPS70451PWPR	HTSSOP	PWP	24	2000	367.0	367.0	38.0
TPS70458PWPR	HTSSOP	PWP	24	2000	367.0	367.0	38.0

MECHANICAL DATA

PWP (R-PDSO-G24)

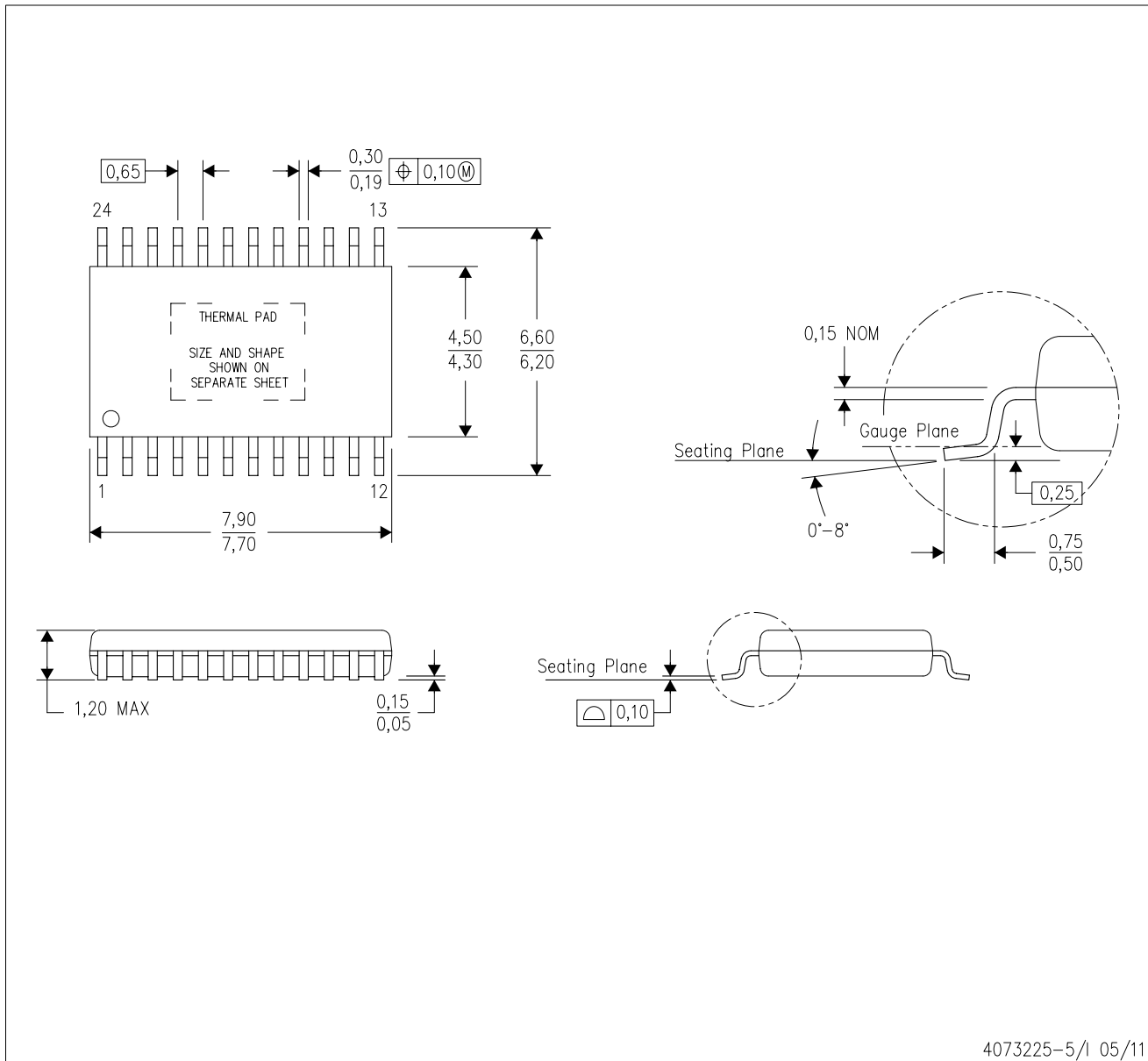
PowerPAD™ PLASTIC SMALL OUTLINE



- NOTES:
- All linear dimensions are in millimeters.
 - This drawing is subject to change without notice.
 - Body dimensions do not include mold flash or protrusions. Mold flash and protrusion shall not exceed 0.15 per side.
 - This package is designed to be soldered to a thermal pad on the board. Refer to Technical Brief, PowerPad Thermally Enhanced Package, Texas Instruments Literature No. SLMA002 for information regarding recommended board layout. This document is available at www.ti.com <<http://www.ti.com>>.
 - See the additional figure in the Product Data Sheet for details regarding the exposed thermal pad features and dimensions.
 - Falls within JEDEC MO-153

PowerPAD is a trademark of Texas Instruments.

THERMAL PAD MECHANICAL DATA

PWP (R-PDSO-G24) PowerPAD™ SMALL PLASTIC OUTLINE

THERMAL INFORMATION

This PowerPAD™ package incorporates an exposed thermal pad that is designed to be attached to a printed circuit board (PCB). The thermal pad must be soldered directly to the PCB. After soldering, the PCB can be used as a heatsink. In addition, through the use of thermal vias, the thermal pad can be attached directly to the appropriate copper plane shown in the electrical schematic for the device, or alternatively, can be attached to a special heatsink structure designed into the PCB. This design optimizes the heat transfer from the integrated circuit (IC).

For additional information on the PowerPAD package and how to take advantage of its heat dissipating abilities, refer to Technical Brief, PowerPAD Thermally Enhanced Package, Texas Instruments Literature No. SLMA002 and Application Brief, PowerPAD Made Easy, Texas Instruments Literature No. SLMA004. Both documents are available at www.ti.com.

The exposed thermal pad dimensions for this package are shown in the following illustration.

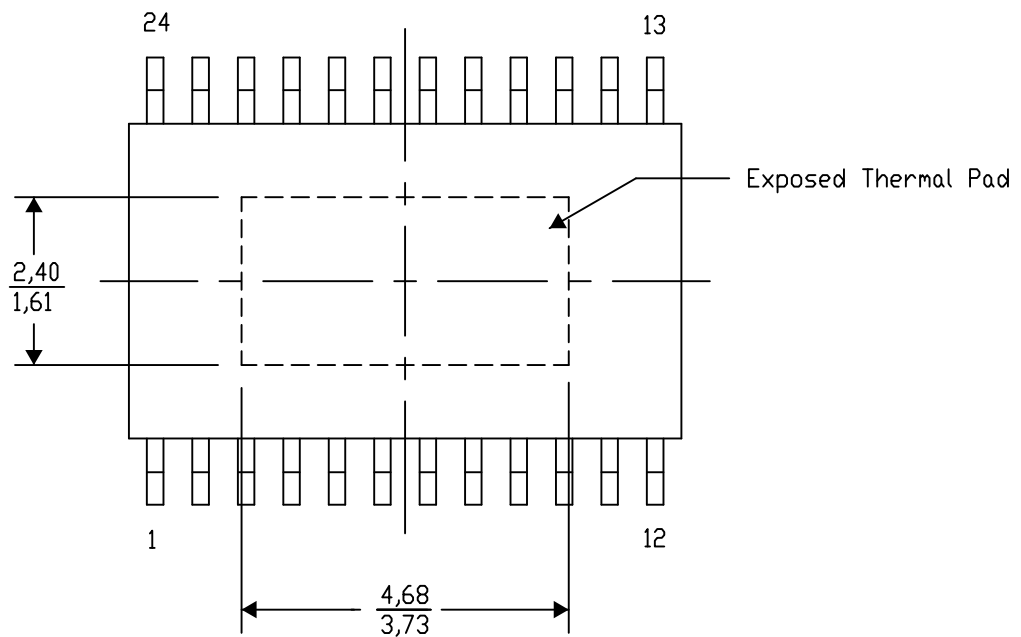

Top View

Exposed Thermal Pad Dimensions

4206332-27/AC 07/12

NOTE: A. All linear dimensions are in millimeters

PowerPAD is a trademark of Texas Instruments

PWP (R-PDSO-G24)

PowerPAD™ PLASTIC SMALL OUTLINE

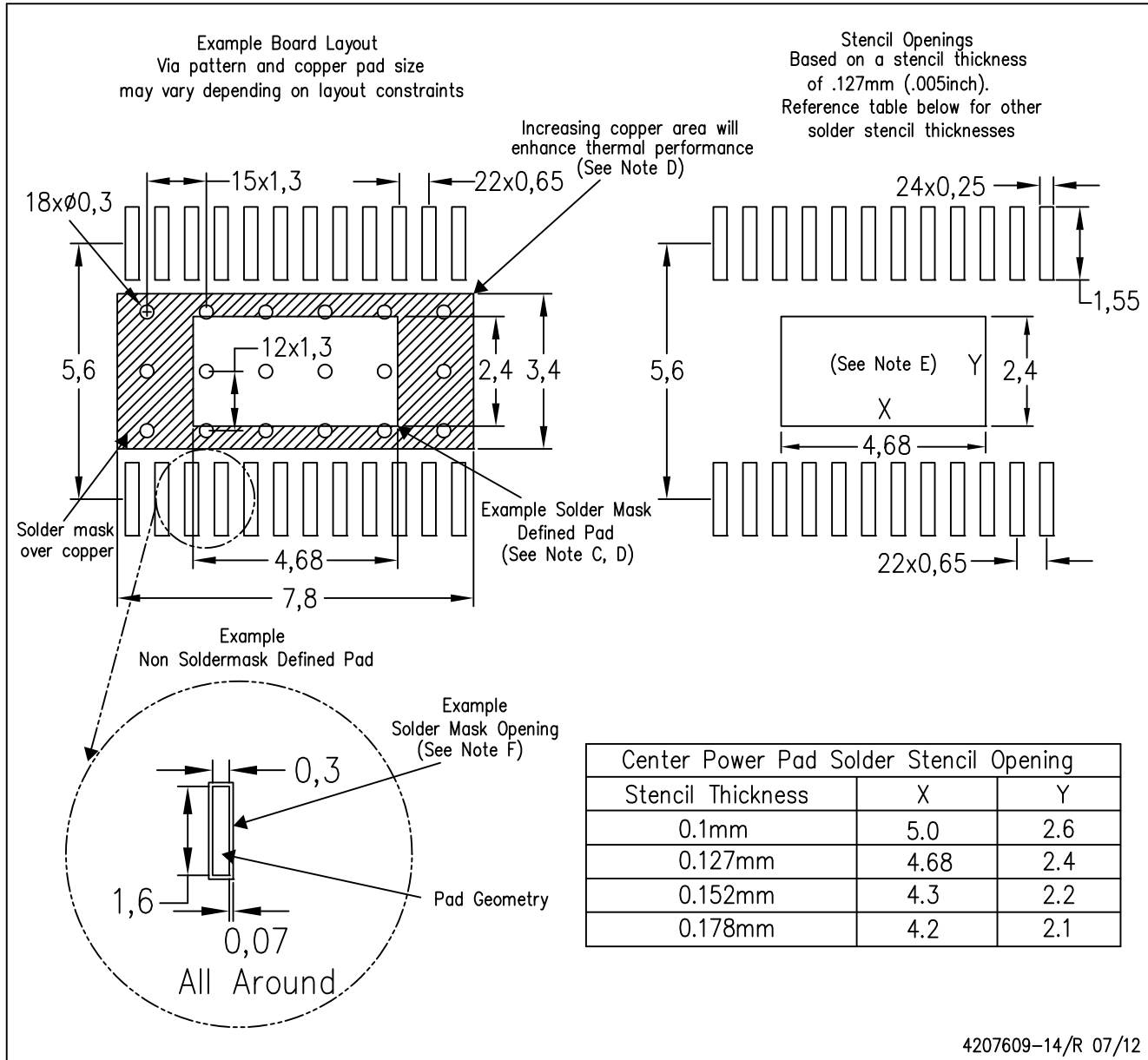

- NOTES:
- All linear dimensions are in millimeters.
 - This drawing is subject to change without notice.
 - Customers should place a note on the circuit board fabrication drawing not to alter the center solder mask defined pad.
 - This package is designed to be soldered to a thermal pad on the board. Refer to Technical Brief, PowerPad Thermally Enhanced Package, Texas Instruments Literature No. SLMA002, SLMA004, and also the Product Data Sheets for specific thermal information, via requirements, and recommended board layout. These documents are available at www.ti.com <<http://www.ti.com>>. Publication IPC-7351 is recommended for alternate designs.
 - Laser cutting apertures with trapezoidal walls and also rounding corners will offer better paste release. Customers should contact their board assembly site for stencil design recommendations. Example stencil design based on a 50% volumetric metal load solder paste. Refer to IPC-7525 for other stencil recommendations.
 - Customers should contact their board fabrication site for solder mask tolerances between and around signal pads.

IMPORTANT NOTICE

Texas Instruments Incorporated and its subsidiaries (TI) reserve the right to make corrections, enhancements, improvements and other changes to its semiconductor products and services per JESD46C and to discontinue any product or service per JESD48B. Buyers should obtain the latest relevant information before placing orders and should verify that such information is current and complete. All semiconductor products (also referred to herein as "components") are sold subject to TI's terms and conditions of sale supplied at the time of order acknowledgment.

TI warrants performance of its components to the specifications applicable at the time of sale, in accordance with the warranty in TI's terms and conditions of sale of semiconductor products. Testing and other quality control techniques are used to the extent TI deems necessary to support this warranty. Except where mandated by applicable law, testing of all parameters of each component is not necessarily performed.

TI assumes no liability for applications assistance or the design of Buyers' products. Buyers are responsible for their products and applications using TI components. To minimize the risks associated with Buyers' products and applications, Buyers should provide adequate design and operating safeguards.

TI does not warrant or represent that any license, either express or implied, is granted under any patent right, copyright, mask work right, or other intellectual property right relating to any combination, machine, or process in which TI components or services are used. Information published by TI regarding third-party products or services does not constitute a license to use such products or services or a warranty or endorsement thereof. Use of such information may require a license from a third party under the patents or other intellectual property of the third party, or a license from TI under the patents or other intellectual property of TI.

Reproduction of significant portions of TI information in TI data books or data sheets is permissible only if reproduction is without alteration and is accompanied by all associated warranties, conditions, limitations, and notices. TI is not responsible or liable for such altered documentation. Information of third parties may be subject to additional restrictions.

Resale of TI components or services with statements different from or beyond the parameters stated by TI for that component or service voids all express and any implied warranties for the associated TI component or service and is an unfair and deceptive business practice. TI is not responsible or liable for any such statements.

Buyer acknowledges and agrees that it is solely responsible for compliance with all legal, regulatory and safety-related requirements concerning its products, and any use of TI components in its applications, notwithstanding any applications-related information or support that may be provided by TI. Buyer represents and agrees that it has all the necessary expertise to create and implement safeguards which anticipate dangerous consequences of failures, monitor failures and their consequences, lessen the likelihood of failures that might cause harm and take appropriate remedial actions. Buyer will fully indemnify TI and its representatives against any damages arising out of the use of any TI components in safety-critical applications.

In some cases, TI components may be promoted specifically to facilitate safety-related applications. With such components, TI's goal is to help enable customers to design and create their own end-product solutions that meet applicable functional safety standards and requirements. Nonetheless, such components are subject to these terms.

No TI components are authorized for use in FDA Class III (or similar life-critical medical equipment) unless authorized officers of the parties have executed a special agreement specifically governing such use.

Only those TI components which TI has specifically designated as military grade or "enhanced plastic" are designed and intended for use in military/aerospace applications or environments. Buyer acknowledges and agrees that any military or aerospace use of TI components which have **not** been so designated is solely at the Buyer's risk, and that Buyer is solely responsible for compliance with all legal and regulatory requirements in connection with such use.

TI has specifically designated certain components which meet ISO/TS16949 requirements, mainly for automotive use. Components which have not been so designated are neither designed nor intended for automotive use; and TI will not be responsible for any failure of such components to meet such requirements.

Products

Audio	www.ti.com/audio
Amplifiers	amplifier.ti.com
Data Converters	dataconverter.ti.com
DLP® Products	www.dlp.com
DSP	dsp.ti.com
Clocks and Timers	www.ti.com/clocks
Interface	interface.ti.com
Logic	logic.ti.com
Power Mgmt	power.ti.com
Microcontrollers	microcontroller.ti.com
RFID	www.ti-rfid.com
OMAP Mobile Processors	www.ti.com/omap
Wireless Connectivity	www.ti.com/wirelessconnectivity

Applications

Automotive and Transportation	www.ti.com/automotive
Communications and Telecom	www.ti.com/communications
Computers and Peripherals	www.ti.com/computers
Consumer Electronics	www.ti.com/consumer-apps
Energy and Lighting	www.ti.com/energy
Industrial	www.ti.com/industrial
Medical	www.ti.com/medical
Security	www.ti.com/security
Space, Avionics and Defense	www.ti.com/space-avionics-defense
Video and Imaging	www.ti.com/video

TI E2E Community e2e.ti.com