

High-Power Dual-Band (2.4-GHz to 2.5-GHz and 4.9-GHz to 5.9-GHz) RF Front-End

FEATURES

- Highly Integrated 802.16 d/e Radio Frequency Front End ASIC
- Fully Integrated Up/Down Converters, LNAs, PAs and T/R Switches
- Super Heterodyne Architecture for Superior Adjacent Channel Rejection Performance
- Differential LO and IF Interface for Enhanced Spurious/EMI Performance
- Common Frequency Plan uses a Single LO and Common IF for Single IF Filter for Both Bands
- Integrated Temperature Compensated TX Power Detectors
- PA Bias Control Function
- Antenna Port $OP_{1dB} = +23$ dBm Typical
- Antenna Port $OIP3 = +33$ dBm, Typical
- Frequency Range: 2.4 to 2.5 and 4.9 to 5.9 GHz
- Noise Figure: 4 dB ISM Band, 6 dB 5 GHz Bands Typical
- Typical Gain: 38 dB TX, 20 dB RX
- IF = 374 MHz

TRF2436 PACKAGE
(TOP VIEW)

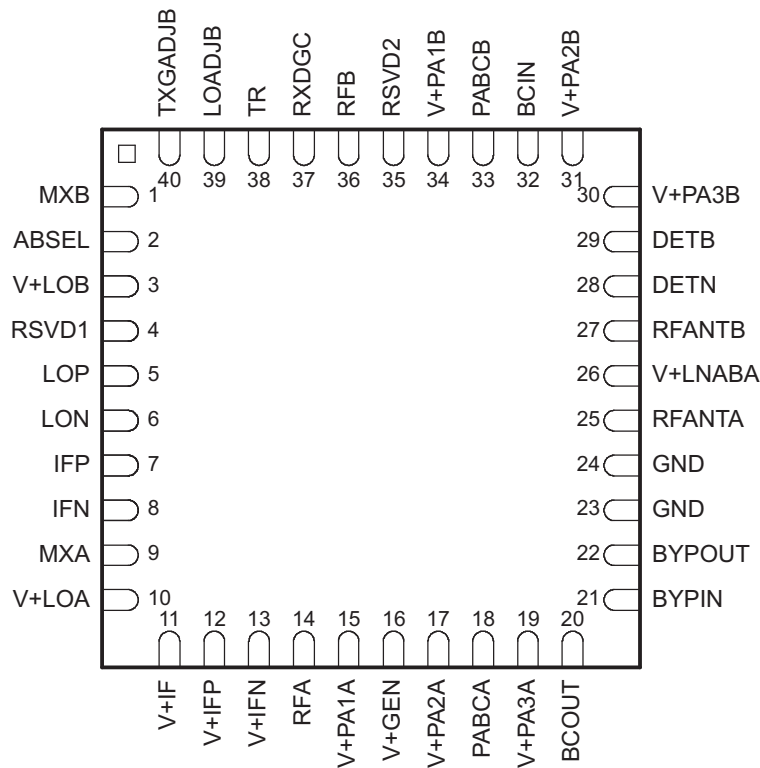

Please be aware that an important notice concerning availability, standard warranty, and use in critical applications of Texas Instruments semiconductor products and disclaimers thereto appears at the end of this data sheet.



These devices have limited built-in ESD protection. The leads should be shorted together or the device placed in conductive foam during storage or handling to prevent electrostatic damage to the MOS gates.

DESCRIPTION

The TRF2436 is a fully integrated Dual Band Tri Mode Radio Frequency Front End (RFFE) designed specifically for use in 802.16 d/e applications. The TRF2436 is designed to perform RF up and down conversions in the unlicensed ISM and 4.9-5.9 GHz bands. The TRF2436 uses a common IF frequency for both bands, eliminating the need for additional IF filtering. Combined with the TI TRF2432 IF/IQ Transceiver/Synthesizer, the TRF2436 completes the TI WLAN two-chip radio.

The TRF2436 incorporates all of the RF blocks for both the “b” and “a” bands except for low cost ceramic filters. The ASIC includes LNAs, PAs, mixers, bias circuitry, RX gain control, transmit coupler detectors, and T/R switches. High integration and internal RF matching enhances performance and greatly reduce external part count. The only external components needed (other than simple passives) for operation are RF filters and external low power DC switching FETs.

Functional Block Diagram

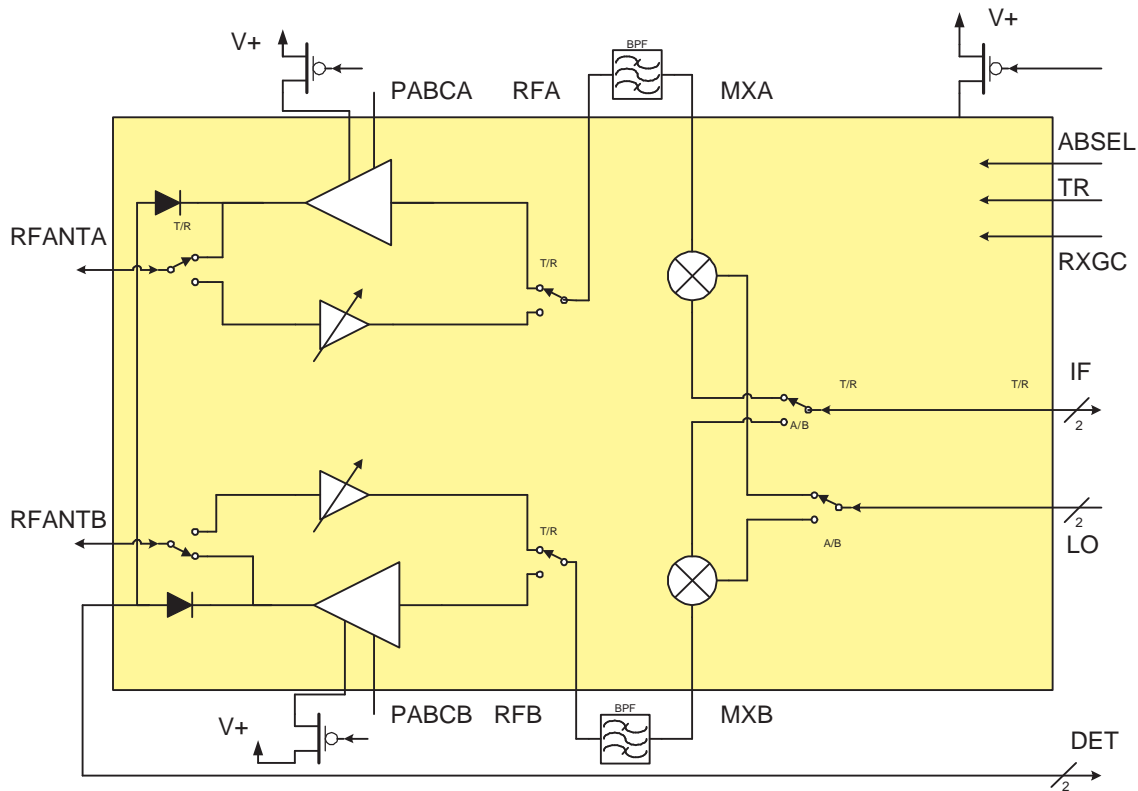

DEVICE INFORMATION

TERMINAL FUNCTIONS

TERMINAL		I/O	TYPE	DESCRIPTION
NAME	NO.			
MXB	1	I/O	RF SE	B band RF Input/Output to mixer. 50-Ω single ended. Do not apply DC.
ABSEL	2	I	Digital	Band select pin. HIGH = A-band. LOW = B-band.
V+LOB	3	I	Power	B band LO amplifier bias +3.3V
RSVD1	4	-	-	Not connected for normal operation. Leave Open.
LOP	5	I	RF Dif.	LO input (differential) Positive, AC coupled

DEVICE INFORMATION (continued)
TERMINAL FUNCTIONS (continued)

TERMINAL		I/O	TYPE	DESCRIPTION
NAME	NO.			
LON	6	I	RF Dif.	LO input (differential) Negative, AC coupled
IFP	7	I/O	RF Dif.	IF input/output (differential) Positive, DC coupled, typical DC Voltage is 2.6V
IFN	8	I/O	RF Dif.	IF input/output(differential) Negative, DC coupled, typical DC Voltage is 2.6V
MXA	9	I/O	RF SE	A band RF Input/Output to mixer. 50-Ω single ended. Do not apply DC.
V+LOA	10	I	Power	A band LO amplifier bias +3.3V
V+IF	11	I	Power	IF amplifier bias +3.3V.
V+IFP	12	I	Power	IFP amplifier bias +3.3V.
V+IFN	13	I	Power	IFN amplifier bias +3.3V.
RFA	14	I/O	RF SE	A Band RF Input/Output to PA/LNA. 50-Ω single ended. AC coupled.
V+PA1A	15	I	Power	A band Power amplifier bias +3.3V.
V+GEN	16	I	Power	DC Bias Control Bias +3.3V.
V+PA2A	17	I	Power	A band Power amplifier bias +3.3V.
PABCA	18	-	-	A band PA Bias Control Input
V+PA3A	19	-	-	A band Power amplifier bias +3.3V.
BCOUT	20	O	Analog	Bias Control Output.
BYPIN	21	I	Analog	DC Bias Bypass Input
BYPOUT	22	O	Analog	DC Bias Bypass Output
GND	23, 24	-	-	Connect to ground
RFANTA	25	I/O	RF SE	A band RF in/out to antennas. AC coupled.
V+LNABA	26	I	Power	A and B Band LNA bias +3.3V.
RFANTB	27	I/O	RF SE	B band RF in/out to antennas. AC coupled.
DETN	28	O	Analog	Negative RF power detector output
DETP	29	O	Analog	Positive RF power detector output.
V+PA3B	30	I	Power	B band Power amplifier bias +3.3V.
V+PA2B	31	I	Power	B band Power amplifier bias +3.3V.
BCIN	32	I	Analog	Bias control input
PABCB	33	-	-	B band PA Bias Control Input
V+PA1B	34	I	Power	B band Power amplifier bias +3.3V.
RSVD2	35	-	-	Not Connected for normal operation. Leave Open.
RFB	36	I/O	RF SE	B band RF Input/Output to PA/LNA. 50-Ω single ended. AC coupled.
RXDGC	37	I	Digital	Rx Gain Control. HIGH = minimum gain. LOW = maximum gain
TR	38	I	Digital	Transmit/Receive mode control. HIGH = transmit. LOW = receive.
LOADJB	39	-	-	Not connected for normal operation. Leave Open. B band LO amp bias adjust.
TXGADJB	40	-	-	Not connected for normal operation. Leave open. PAB Amplifier bias adjust.

ABSOLUTE MAXIMUM RATINGS

over operating free-air temperature range (unless otherwise noted)

			VALUE	UNIT
V _{CC}	DC supply voltage		0 to 6.9	V
I _{CC}	DC supply current		600	mA
	RF input power	Any port and any mode	10	dBm
V _{ID}	Digital input voltage		-0.3 to 5	V
T _{JC}	Junction temperature		175	°C
θ _{JC}	Thermal resistance junction-to-case		35	°C/W
T _A	Operating temperature		-20 to 85	°C
T _{stg}	Storage temperature		-40 to 105	°C
	Lead temperature	40 sec maximum	220	°C

DC CHARACTERISTICSTYP ratings are at 25°C and V_{CC} = 3.3 V, MIN and MAX ratings are over operating free-air temperature and voltage ranges (unless otherwise noted)

PARAMETER		TEST CONDITIONS	MIN	TYP	MAX	UNIT
V _{CC}	Supply voltage	Specification compliant	2.7	3.3	4.2	V
I _{CC}	Total supply current	B Band, RX Mode		65	105	mA
		A Band, RX Mode		80	120	mA
		B Band, TX Mode, Max PABC input		410	520	mA
		A Band, TX Mode, Max PABC input		450	550	mA
V _{IH}	High-level input voltage		1.7			V
V _{IL}	Low-level input voltage				0.5	V
I _{IH}	High-level input current			100	300	μA
I _{IL}	Low-level input current				-50	μA

RECEIVER CHARACTERISTICSTR = Low, 2 dB base band filter loss in RX band, MIN, TYP, and MAX rating are at 25°C and V_{CC} = 3.3 V (unless otherwise noted)

PARAMETER		TEST CONDITIONS	MIN	TYP	MAX	UNIT
f _{IRF}	RF input frequency	B band	2400		2500	MHz
		A band	4900		5900	
f _{LO}	LO input frequency	B band	2774		2874	MHz
		A band	2637		3137	
f _{IF}	IF input frequency			374		MHz
G	Gain	B Band High Gain Mode RXGC=LOW	17	19		dB
		A Band High Gain Mode RXGC=LOW	18	23		
ΔG	Gain step size	B Band Low Gain Mode RXGC=HIGH		25		dB
		A Band Low Gain Mode RXGC=HIGH		15		
	Noise figure	B Band. Max Gain		4	5	dB
		A Band. Max Gain		6	7.5	

RECEIVER CHARACTERISTICS (continued)

TR = Low, 2 dB base band filter loss in RX band, MIN, TYP, and MAX rating are at 25°C and $V_{CC} = 3.3$ V (unless otherwise noted)

PARAMETER		TEST CONDITIONS	MIN	TYP	MAX	UNIT
Input P _{-1dB}		B Band High Gain Mode RXGC=LOW	-16	-13		dBm
		B Band Low Gain Mode RXGC=HIGH				
		A Band High Gain Mode RXGC=LOW	-22	-18		
		A Band Low Gain Mode RXGC=HIGH	-16	-13		
Input 3rd order intercept point		B Band High Gain Mode RXGC=LOW	-6	-2		dBm
		B Band Low Gain Mode RXGC=HIGH	4	8		
		A Band High Gain Mode RXGC=LOW	-12	-8		
		A Band Low Gain Mode RXGC=HIGH	-6	-3		
RF input return loss	Z = 50 Ω Both Bands, Both Gain modes	8			dB	
LNA out return loss RF	Z = 50 Ω Both Bands, Both Gain modes	9			dB	
Mixer input MX return loss	Z = 50 Ω Both Bands	10			dB	
Output return loss	Measured into 200 Ω differential	10			dB	
LO at MX leakage		B band		-30		dBm
		A Band (5274-6274 MHz)		-30		
LO at IF leakage		Both bands		-40		dBm
Gain flatness full band		B band		1		dB
		A band		2		
Gain flatness / 22 MHz		Both bands				dB
Gain settling time		Full range to within 0.5 dB final. All bands		0.3		μ s
RF to RFANT isolation		In Band: B Band High Gain Mode RXGC=LOW		30		dB
		In Band: B Band Low Gain Mode RXGC=HIGH		5		
		In Band: A Band High Gain Mode RXGC=LOW		25		
		In Band: A Band Low Gain Mode RXGC=HIGH		35		

TRANSMITTER CHARACTERISTICS

TR = High, 2 dB base band filter loss in RX band, MIN, TYP, and MAX rating are at 25°C and $V_{CC} = 3.3$ V (unless otherwise noted)

PARAMETER		TEST CONDITIONS	MIN	TYP	MAX	UNIT
f _{IF}	IF input frequency			374		MHz
f _{ORF}	RF output frequency	B band	2400		2500	MHz
		A band	4900		5900	MHz
f _{LO}	LO input frequency	B band	2774		2874	MHz
		A band	2637		3137	MHz
G	Gain	B Band	37	40		dB
		A Band	40	43		dB

TRANSMITTER CHARACTERISTICS (continued)

TR = High, 2 dB base band filter loss in RX band, MIN, TYP, and MAX rating are at 25°C and $V_{CC} = 3.3$ V (unless otherwise noted)

PARAMETER		TEST CONDITIONS	MIN	TYP	MAX	UNIT
	Output 1 dB gain compression	B band. max PABC input	22	23.5		dBm
		A band. max PABC input	20.5	22.5		dBm
		5150 – 5350 MHz Max PABC input, $V_{+PA} = 2.9$ V min, Other $V_{CC} = 2.7$ V min	20.5	22.5		dBm
	Output 3rd order intercept	B band	32	35		dBm
		A band	30	32.5		dBm
	Noise figure	Both bands		8		dB
	IF input return loss	Measured into 200 Ω differential	8			dB
	Mixer output return loss MX	Z = 50 Ω both bands	10			dB
	RF input return loss RF	Z = 50 Ω both bands	8			dB
	RFANT return loss	Z = 50 Ω both bands	6			dB
I_{kq}	LO leakage at MX	B band		-35		dBm
		A band (5274-6274 MHz)		-35		dBm
	Gain flatness full band	B band		1		dB
		A band		2		dB
	Gain flatness / 22 MHz	Both bands				dB
	PA harmonics	Both bands CW at P1 dB			-20	dBc
	RFANT to RF isolation	B band		50		dB
		A band		50		dB
	PA Off Isolation RF to RFANT	In band: both bands	50			dB
	PA Turn On Time	To within 0.5 dB max power		0.2		μ s
	PA Turn Off Time	To within -20 dB max power		0.2		μ s
	PA droop	From max power after turn-on time, Maximum on duration is 200 ms			0.5	dB
	PA Bias Control Input Range (PABC)	Max Current corresponds to max PA bias state				mA

COMMON ELECTRICAL CHARACTERISTICS

MIN, TYP, and MAX ratings are at 25°C and $V_{CC} = 3.3$ V (unless otherwise noted)

PARAMETER		TEST CONDITIONS	MIN	TYP	MAX	UNIT
	TR_SEL switch time	Gain within 0.5dB. Not Including PA ramp time		0.3	1	μ s
	AB_SEL switch time				1	μ s
	LO input power	Reference to 100 Ω differential	-1		5	dBm
	LO input return loss	Measured to 100 Ω differential at 25°C	6			
	IF port impedance	Differential		200		Ω
	LO port impedance			100		Ω

TYPICAL CHARACTERISTICS

A Band Detector Output

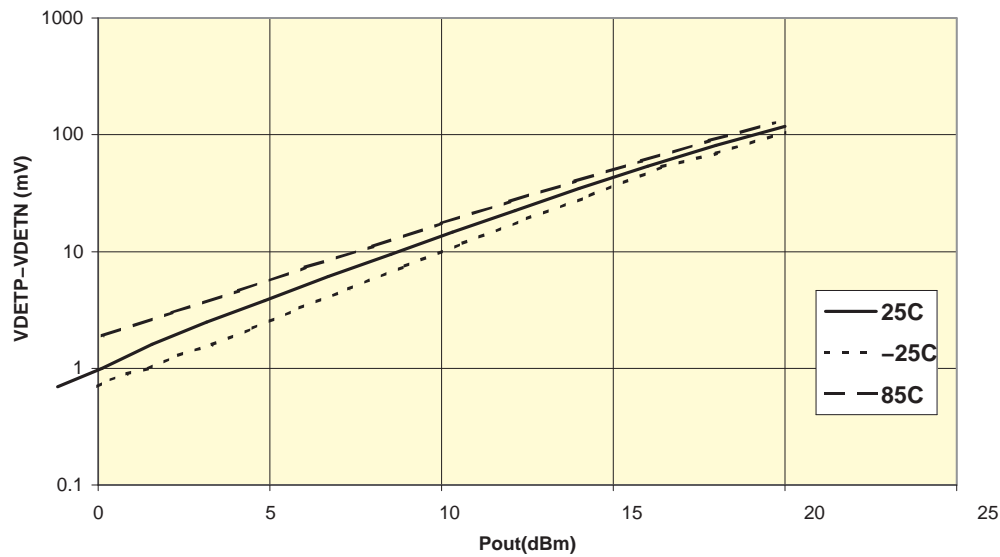

Figure 1. A Band Detector Output

B Band Detector Output



Figure 2. B Band Detector Output

PACKAGING INFORMATION

Orderable Device	Status ⁽¹⁾	Package Type	Package Drawing	Pins	Package Qty	Eco Plan ⁽²⁾	Lead/Ball Finish	MSL Peak Temp ⁽³⁾
TRF2436IRTBR	ACTIVE	QFN	RTB	40	2500	Green (RoHS & no Sb/Br)	CU SN	Level-3-260C-168 HR
TRF2436IRTBRG4	ACTIVE	QFN	RTB	40	2500	Green (RoHS & no Sb/Br)	CU SN	Level-3-260C-168 HR
TRF2436IRTBT	ACTIVE	QFN	RTB	40	250	Green (RoHS & no Sb/Br)	CU SN	Level-3-260C-168 HR
TRF2436IRBTG4	ACTIVE	QFN	RTB	40	250	Green (RoHS & no Sb/Br)	CU SN	Level-3-260C-168 HR

⁽¹⁾ The marketing status values are defined as follows:

ACTIVE: Product device recommended for new designs.

LIFEBUY: TI has announced that the device will be discontinued, and a lifetime-buy period is in effect.

NRND: Not recommended for new designs. Device is in production to support existing customers, but TI does not recommend using this part in a new design.

PREVIEW: Device has been announced but is not in production. Samples may or may not be available.

OBSOLETE: TI has discontinued the production of the device.

⁽²⁾ Eco Plan - The planned eco-friendly classification: Pb-Free (RoHS), Pb-Free (RoHS Exempt), or Green (RoHS & no Sb/Br) - please check <http://www.ti.com/productcontent> for the latest availability information and additional product content details.

TBD: The Pb-Free/Green conversion plan has not been defined.

Pb-Free (RoHS): TI's terms "Lead-Free" or "Pb-Free" mean semiconductor products that are compatible with the current RoHS requirements for all 6 substances, including the requirement that lead not exceed 0.1% by weight in homogeneous materials. Where designed to be soldered at high temperatures, TI Pb-Free products are suitable for use in specified lead-free processes.

Pb-Free (RoHS Exempt): This component has a RoHS exemption for either 1) lead-based flip-chip solder bumps used between the die and package, or 2) lead-based die adhesive used between the die and leadframe. The component is otherwise considered Pb-Free (RoHS compatible) as defined above.

Green (RoHS & no Sb/Br): TI defines "Green" to mean Pb-Free (RoHS compatible), and free of Bromine (Br) and Antimony (Sb) based flame retardants (Br or Sb do not exceed 0.1% by weight in homogeneous material)

⁽³⁾ MSL, Peak Temp. -- The Moisture Sensitivity Level rating according to the JEDEC industry standard classifications, and peak solder temperature.

Important Information and Disclaimer:The information provided on this page represents TI's knowledge and belief as of the date that it is provided. TI bases its knowledge and belief on information provided by third parties, and makes no representation or warranty as to the accuracy of such information. Efforts are underway to better integrate information from third parties. TI has taken and continues to take reasonable steps to provide representative and accurate information but may not have conducted destructive testing or chemical analysis on incoming materials and chemicals. TI and TI suppliers consider certain information to be proprietary, and thus CAS numbers and other limited information may not be available for release.

In no event shall TI's liability arising out of such information exceed the total purchase price of the TI part(s) at issue in this document sold by TI to Customer on an annual basis.

TAPE AND REEL BOX INFORMATION

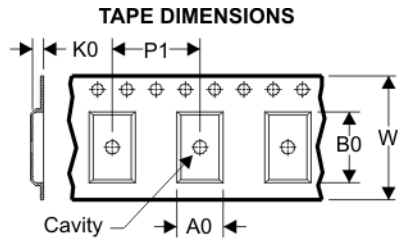
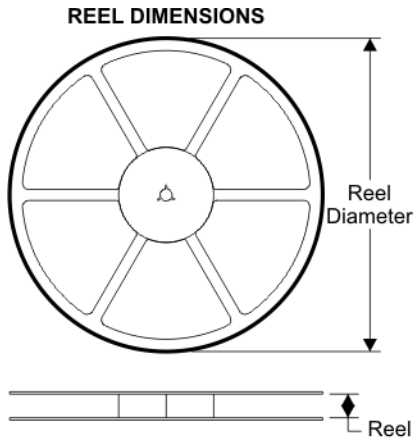

A0	Dimension designed to accommodate the component width
B0	Dimension designed to accommodate the component length
K0	Dimension designed to accommodate the component thickness
W	Overall width of the carrier tape
P1	Pitch between successive cavity centers

QUADRANT ASSIGNMENTS FOR PIN 1 ORIENTATION IN TAPE

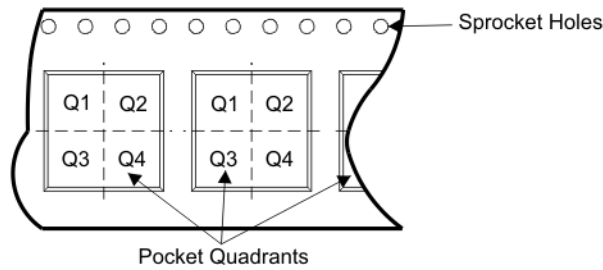

Device	Package	Pins	Site	Reel Diameter (mm)	Reel Width (mm)	A0 (mm)	B0 (mm)	K0 (mm)	P1 (mm)	W (mm)	Pin1 Quadrant
TRF2436IRTBR	RTB	40	SITE 60	330	16	6.3	6.3	1.5	12	16	Q2
TRF2436IRTBT	RTB	40	SITE 60	330	16	6.3	6.3	1.5	12	16	Q2

TAPE AND REEL BOX DIMENSIONS



Device	Package	Pins	Site	Length (mm)	Width (mm)	Height (mm)
TRF2436IRTBR	RTB	40	SITE 60	342.9	336.6	28.58
TRF2436IRTBT	RTB	40	SITE 60	342.9	336.6	28.58

RTB (S-PQFP-N40)

PLASTIC QUAD FLATPACK

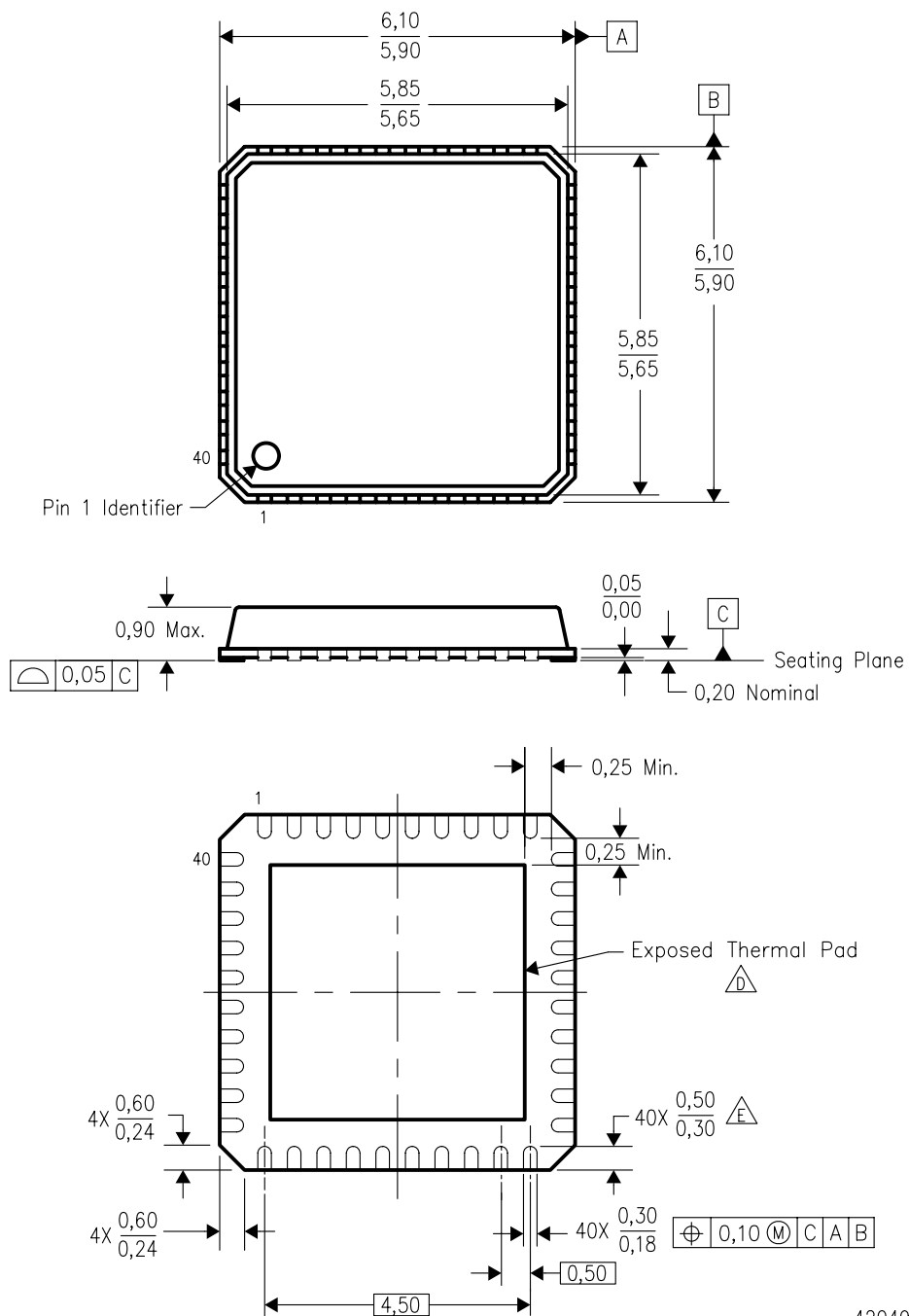

- NOTES: A. All linear dimensions are in millimeters.
 Dimensioning and tolerancing per ASME Y14.5M-1994.
 B. This drawing is subject to change without notice.
 C. QFN (Quad Flatpack No-Lead) Package configuration.
- The package thermal pad must be soldered to the board for thermal and mechanical performance. See the Product Data Sheet for details regarding the exposed thermal pad dimensions.
 Some products have selected lands extended past 0,50 length. See Product Data Sheet for details regarding specific land length exceptions.

THERMAL INFORMATION

This package incorporates an exposed thermal pad that is designed to be attached directly to an external heatsink. The thermal pad must be soldered directly to the printed circuit board (PCB). After soldering, the PCB can be used as a heatsink. In addition, through the use of thermal vias, the thermal pad can be attached directly to the appropriate copper plane shown in the electrical schematic for the device, or alternatively, can be attached to a special heatsink structure designed into the PCB. This design optimizes the heat transfer from the integrated circuit (IC).

For information on the Quad Flatpack No-Lead (QFN) package and its advantages, refer to Application Report, Quad Flatpack No-Lead Logic Packages, Texas Instruments Literature No. SCBA017. This document is available at www.ti.com.

The exposed thermal pad dimensions for this package are shown in the following illustration.

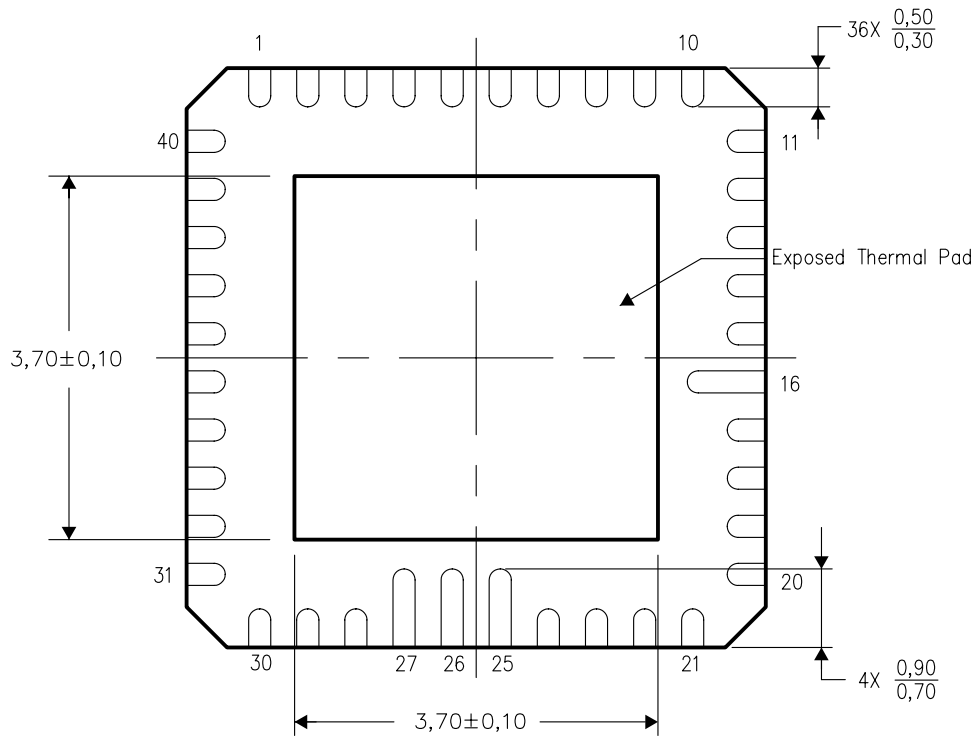

Bottom View



NOTE: All linear dimensions are in millimeters

Exposed Thermal Pad Dimensions

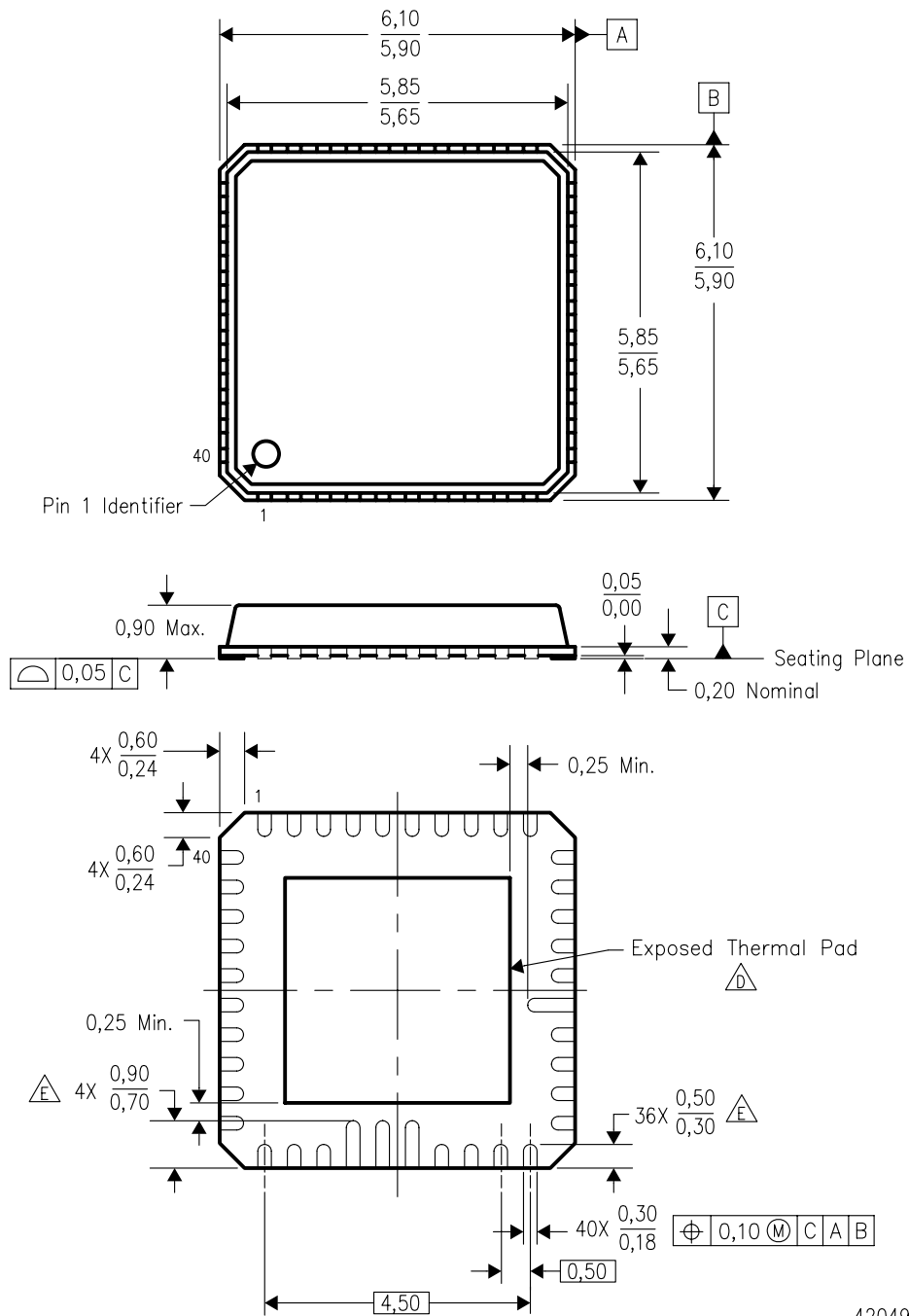
RTB (S-PQFP-N40) *LONG LEAD OPTION* PLASTIC QUAD FLATPACK



4204967-3/E 05/07

- NOTES: A. All linear dimensions are in millimeters.  The package thermal pad must be soldered to the board for thermal and mechanical performance. See the Product Data Sheet for details regarding the exposed thermal pad dimensions.
- B. This drawing is subject to change without notice.
- C. QFN (Quad Flatpack No-Lead) Package configuration.  Selected lands extended past 0,50 length.

THERMAL INFORMATION

This package incorporates an exposed thermal pad that is designed to be attached directly to an external heatsink. The thermal pad must be soldered directly to the printed circuit board (PCB). After soldering, the PCB can be used as a heatsink. In addition, through the use of thermal vias, the thermal pad can be attached directly to the appropriate copper plane shown in the electrical schematic for the device, or alternatively, can be attached to a special heatsink structure designed into the PCB. This design optimizes the heat transfer from the integrated circuit (IC).

For information on the Quad Flatpack No-Lead (QFN) package and its advantages, refer to Application Report, Quad Flatpack No-Lead Logic Packages, Texas Instruments Literature No. SCBA017. This document is available at www.ti.com.

The exposed thermal pad dimensions for this package are shown in the following illustration.

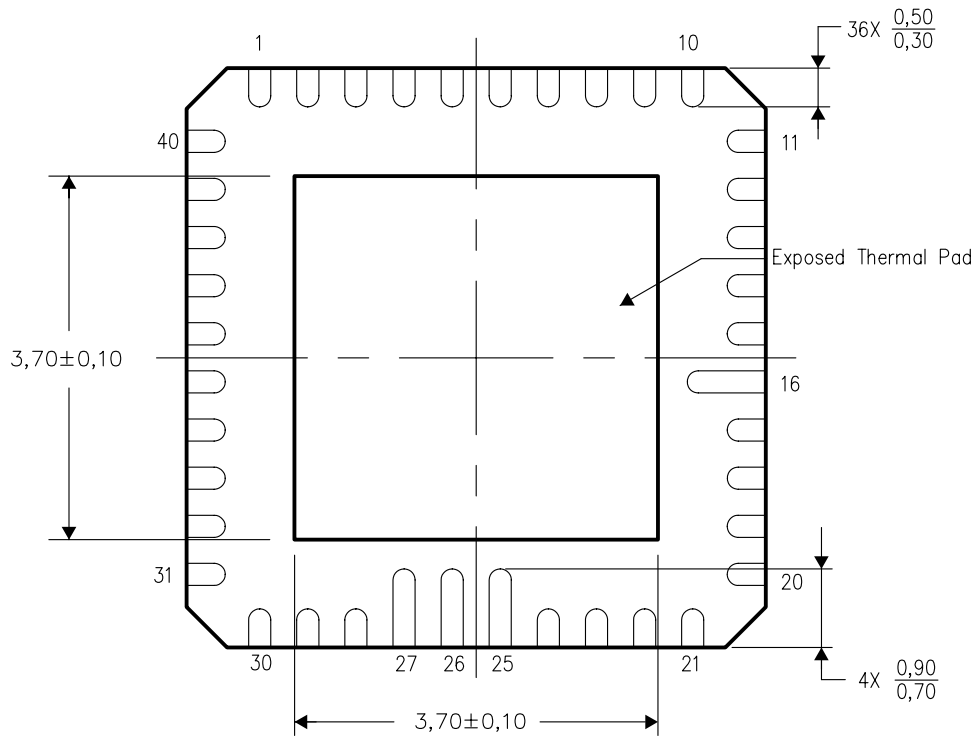

Bottom View

NOTE: All linear dimensions are in millimeters

Exposed Thermal Pad Dimensions

IMPORTANT NOTICE

Texas Instruments Incorporated and its subsidiaries (TI) reserve the right to make corrections, modifications, enhancements, improvements, and other changes to its products and services at any time and to discontinue any product or service without notice. Customers should obtain the latest relevant information before placing orders and should verify that such information is current and complete. All products are sold subject to TI's terms and conditions of sale supplied at the time of order acknowledgment.

TI warrants performance of its hardware products to the specifications applicable at the time of sale in accordance with TI's standard warranty. Testing and other quality control techniques are used to the extent TI deems necessary to support this warranty. Except where mandated by government requirements, testing of all parameters of each product is not necessarily performed.

TI assumes no liability for applications assistance or customer product design. Customers are responsible for their products and applications using TI components. To minimize the risks associated with customer products and applications, customers should provide adequate design and operating safeguards.

TI does not warrant or represent that any license, either express or implied, is granted under any TI patent right, copyright, mask work right, or other TI intellectual property right relating to any combination, machine, or process in which TI products or services are used. Information published by TI regarding third-party products or services does not constitute a license from TI to use such products or services or a warranty or endorsement thereof. Use of such information may require a license from a third party under the patents or other intellectual property of the third party, or a license from TI under the patents or other intellectual property of TI.

Reproduction of TI information in TI data books or data sheets is permissible only if reproduction is without alteration and is accompanied by all associated warranties, conditions, limitations, and notices. Reproduction of this information with alteration is an unfair and deceptive business practice. TI is not responsible or liable for such altered documentation. Information of third parties may be subject to additional restrictions.

Resale of TI products or services with statements different from or beyond the parameters stated by TI for that product or service voids all express and any implied warranties for the associated TI product or service and is an unfair and deceptive business practice. TI is not responsible or liable for any such statements.

TI products are not authorized for use in safety-critical applications (such as life support) where a failure of the TI product would reasonably be expected to cause severe personal injury or death, unless officers of the parties have executed an agreement specifically governing such use. Buyers represent that they have all necessary expertise in the safety and regulatory ramifications of their applications, and acknowledge and agree that they are solely responsible for all legal, regulatory and safety-related requirements concerning their products and any use of TI products in such safety-critical applications, notwithstanding any applications-related information or support that may be provided by TI. Further, Buyers must fully indemnify TI and its representatives against any damages arising out of the use of TI products in such safety-critical applications.

TI products are neither designed nor intended for use in military/aerospace applications or environments unless the TI products are specifically designated by TI as military-grade or "enhanced plastic." Only products designated by TI as military-grade meet military specifications. Buyers acknowledge and agree that any such use of TI products which TI has not designated as military-grade is solely at the Buyer's risk, and that they are solely responsible for compliance with all legal and regulatory requirements in connection with such use.

TI products are neither designed nor intended for use in automotive applications or environments unless the specific TI products are designated by TI as compliant with ISO/TS 16949 requirements. Buyers acknowledge and agree that, if they use any non-designated products in automotive applications, TI will not be responsible for any failure to meet such requirements.

Following are URLs where you can obtain information on other Texas Instruments products and application solutions:

Products

Amplifiers	amplifier.ti.com
Data Converters	dataconverter.ti.com
DSP	dsp.ti.com
Clocks and Timers	www.ti.com/clocks
Interface	interface.ti.com
Logic	logic.ti.com
Power Mgmt	power.ti.com
Microcontrollers	microcontroller.ti.com
RFID	www.ti-rfid.com
RF/IF and ZigBee® Solutions	www.ti.com/lprf

Applications

Audio	www.ti.com/audio
Automotive	www.ti.com/automotive
Broadband	www.ti.com/broadband
Digital Control	www.ti.com/digitalcontrol
Medical	www.ti.com/medical
Military	www.ti.com/military
Optical Networking	www.ti.com/opticalnetwork
Security	www.ti.com/security
Telephony	www.ti.com/telephony
Video & Imaging	www.ti.com/video
Wireless	www.ti.com/wireless

Mailing Address: Texas Instruments, Post Office Box 655303, Dallas, Texas 75265
Copyright 2008, Texas Instruments Incorporated