



AUDIO CODEC WITH INTEGRATED HEADPHONE, SPEAKER AMPLIFIER AND TOUCH SCREEN CONTROLLER

FEATURES

- Stereo Audio Playback Up to 48 ksp/s
- Mono Audio Record up to 48 ksp/s
- Integrated PLL for Audio Clock Generation
- Programmable Gain Amplifiers
- Hardware Automatic Gain Control
- Programmable Digital Audio Effects Processing
- Stereo Headset Interface
- Cellular Headset Interface
- 8- Ω Speaker Driver
- 32- Ω Receiver Driver
- Interface with Microphone
- Auto-Detection of Headset and Button Press
- Supports Both Cap and Cap-Less Interface for Headset
- Programmable Audio Routing
- 4-Wire Touch Screen Interface
- Integrated Touch Screen Processor With Fully Automated Modes of Operation
- Programmable Converter Resolution, Speed, and Averaging
- Programmable Autonomous Timing Control
- Direct Battery Measurement
- Built-In Buffer for Touch Screen Data
- SPI™ Serial Interface
- Low Power
- Full Power-Down Control
- 48-Pin QFN Package

APPLICATIONS

- Personal Digital Assistants
- Smart Cellular Phones
- MP3 Players

DESCRIPTION

The TSC2101 is a low-power highly integrated high performance codec and touch screen controller, which supports stereo audio DAC, mono audio ADC and SAR ADC.

The TSC2101 features a high-performance audio codec with 16, 20, 24, or 32-bit stereo playback, mono record functionality at up to 48 ksp/s. The device integrates several analog features such as support for headset interface, cellular headset interface, microphone interface, and speaker and receiver drivers. The device supports auto detection of headset and button press without any glue logic. The TSC2101 has fully programmable audio. The digital audio data format is programmable to work with popular audio standard protocols (I2S, DSP, left/right justified) in master or slave mode, and also includes an on-chip PLL for flexible clock generation capability.

The TSC2101 contains a 12-bit 4-wire resistive touch screen converter complete with drivers, and interfaces to the host controller through a standard SPI™ serial interface. The on-chip processor provides extensive features specifically designed to reduce host processor and bus overhead, with capabilities that include fully automated operating modes, programmable conversion resolution up to 12 bits, programmable sampling rates up to 125 kHz, programmable conversion averaging, and programmable on-chip timing generation.

The TSC2101 offers battery measurement inputs capable of reading battery voltages up to 6 V, while operating at only 3 V. It also has an on-chip temperature sensor capable of reading 0.3°C resolution. The TSC2101 is available in a 48-lead QFN.

US Patent No. 6246394



Please be aware that an important notice concerning availability, standard warranty, and use in critical applications of Texas Instruments semiconductor products and disclaimers thereto appears at the end of this data sheet.

SPI is a trademark of Motorola.



This integrated circuit can be damaged by ESD. Texas Instruments recommends that all integrated circuits be handled with appropriate precautions. Failure to observe proper handling and installation procedures can cause damage.

ESD damage can range from subtle performance degradation to complete device failure. Precision integrated circuits may be more susceptible to damage because very small parametric changes could cause the device not to meet its published specifications.

PACKAGE/ORDERING INFORMATION

PRODUCT	PACKAGE	PACKAGE DESIGNATOR	OPERATING TEMPERATURE RANGE	ORDERING NUMBER	TRANSPORT MEDIA
TSC2101	QFN-48	RGZ	-40°C to +85°C	TSC2101IRGZ	Rails, 52
				TSC2101IRGZR	Tape and Reel, 2500

PIN ASSIGNMENTS

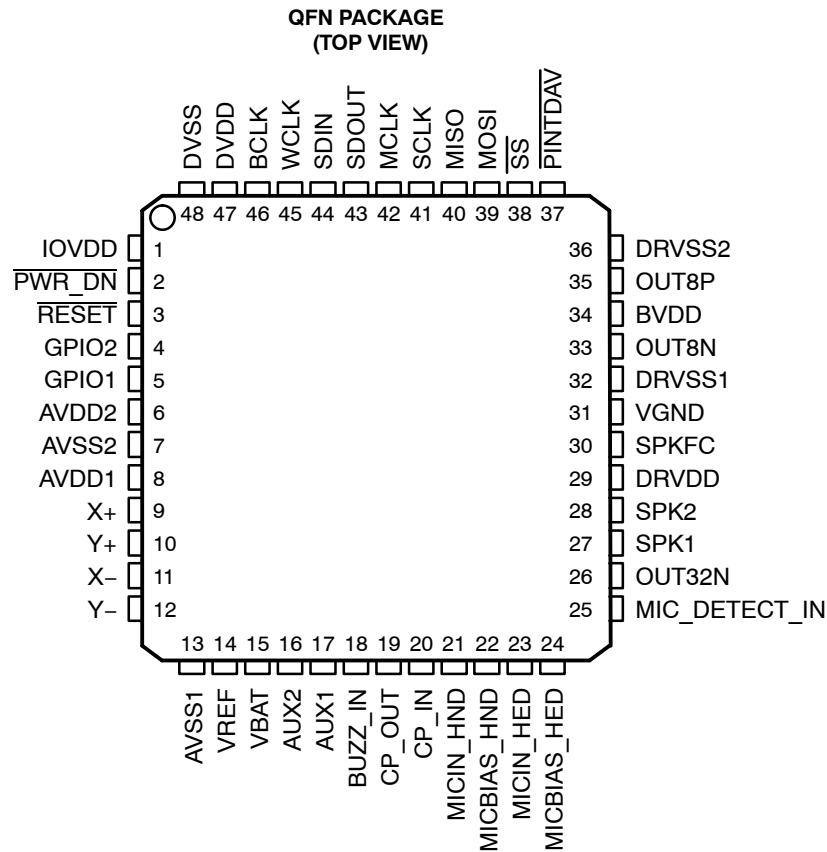

Terminal Functions

PIN	NAME	DESCRIPTION	PIN	NAME	DESCRIPTION
1	IOVDD	IO Supply	25	MIC_DETECT_IN	Microphone detect input
2	PWR_DN	Hardware power down	26	OUT32N	Receiver driver output
3	RESET	Hardware reset	27	SPK1	Headset driver output/receiver driver output
4	GPIO2	General purpose IO	28	SPK2	Headset driver output
5	GPIO1	General purpose IO	29	DRVDD	Headphone driver power supply
6	AVDD2	Touch screen drivers, PLL analog power supply	30	SPKFC	Driver feedback/ speaker detect input
7	AVSS2	Analog ground	31	VGND	Virtual ground for audio output
8	AVDD1	Audio ADC, DAC, reference, SAR ADC analog power supply	32	DRVSS1	Driver ground
9	X+	X+ Position input and driver	33	OUT8N	Loudspeaker driver output
10	Y+	Y+ Position input and driver	34	BVDD	Battery power supply
11	X-	X- Position input and driver	35	OUT8P	Loudspeaker driver output
12	Y-	Y- Position input and driver	36	DRVSS2	Driver ground
13	AVSS1	Analog ground	37	PINTDAV	Pin interrupt/data available output
14	VREF	Reference voltage	38	SS	SPI Slave select input
15	VBAT	Battery monitor input	39	MOSI	SPI Serial data input
16	AUX2	Secondary auxiliary input	40	MISO	SPI Serial data output
17	AUX1	First auxiliary input	41	SCLK	SPI Serial clock input
18	BUZZ_IN	Buzzer input	42	MCLK	Master clock
19	CP_OUT	Output to cell phone module	43	SDOUT	Audio data output
20	CP_IN	Input from cell phone module	44	SDIN	Audio data input
21	MICIN_HND	Handset microphone input	45	WCLK	Audio word clock
22	MICBIAS_HND	Handset microphone bias voltage	46	BCLK	Audio bit clock
23	MICIN_HED	Headset microphone input	47	DVDD	Digital core supply
24	MICBIAS_HED	Headset microphone bias voltage	48	DVSS	Digital core and IO ground

ABSOLUTE MAXIMUM RATINGS

over operating free-air temperature range unless otherwise noted⁽¹⁾, ⁽²⁾

		UNITS
AVDD1/2 to AVSS1/2		-0.3 V to 3.9 V
DRVDD to DRVSS1/2		-0.3 V to 3.9 V
BVDD to DRVSS1/2		-0.3 V to 4.5 V
IOVDD to DVSS		-0.3 V to 3.9 V
Digital input voltage to DVSS		-0.3 V to IOVDD + 0.3 V
Analog input (except VBAT) voltage to AVSS1/2		-0.3 V to AVDD + 0.3 V
VBAT input voltage to AVSS1/2		-0.3 V to 6 V
AVSS1/2 to DRVSS1/2 to DVSS		-0.1 V to 0.1 V
AVDD1/2 to DRVDD		-0.1 V to 0.1 V
Operating temperature range		-40°C to 85°C
Storage temperature range		-65°C to 105°C
Junction temperature (T _J Max)		105°C
QFN package	Power dissipation	(T _J Max - T _A)/θ _{JA}
	θ _{JA} Thermal impedance (with thermal pad soldered to board)	27°C/W
Lead temperature	Infrared (15 sec)	240°C

⁽¹⁾ Stresses beyond those listed under “absolute maximum ratings” may cause permanent damage to the device. These are stress ratings only, and functional operation of the device at these or any other conditions beyond those indicated under “recommended operating conditions” is not implied. Exposure to absolute-maximum-rated conditions for extended periods may affect device reliability.

⁽²⁾ If the TSC2101 is used to drive high power levels to an 8-Ω load for extended intervals at an ambient temperature above 80°C, multiple vias should be used to electrically and thermally connect the thermal pad on the QFN package to an internal heat dissipating ground plane on the user's PCB.

ELECTRICAL CHARACTERISTICSAt +25°C, AVDD1, AVDD2, DRVDD, IOVDD = 3.3 V, BVDD = 3.9 V, DVDD = 1.8 V, V_{ref} = 2.5 V, Fs (Audio) = 48 kHz, unless otherwise noted

PARAMETER	TEST CONDITIONS	MIN	TYP	MAX	UNITS
TOUCH SCREEN					
AUXILIARY ANALOG INPUT					
Input voltage range	AUX1/2 input selected as input by touch-screen	0		+VREF	V
Input capacitance			25		pF
Input leakage current				±1	
BATTERY MONITOR INPUTS					
Input voltage range		0.5		6.0	V
Input leakage current	Battery conversion not selected		±1		µA
Accuracy	Variation across temperature after system calibration at 4 V battery voltage and room temperature		±15		mV
TOUCH SCREEN A/D CONVERTER					
Resolution	Programmable: 8-, 10-, 12-bits	8		12	Bits
No missing codes	12-Bit resolution		11		Bits
Integral nonlinearity		-5		5	LSB
Offset error		-6		6	LSB
Gain error		-6		6	LSB
Noise			50		µVrms
VOLTAGE REFERENCE (VREF)					
Voltage range	VREF output programmed = 2.5 V	2.3	2.5	2.7	V
	VREF output programmed = 1.25 V		1.25		
	External reference	1.1		2.5	V
Reference drift	Internal VREF = 1.25 V		50		ppm/°C
Current drain	Extra current drawn when the internal reference is turned on.		750		µA
AUDIO CODEC					
ADC DECIMATION FILTER CHARACTERISTICS					
Filter gain from 0 to 0.39 Fs			±0.1		dB
Filter gain at 0.4125 Fs			-0.25		dB
Filter gain at 0.45 Fs			-3.0		dB
Filter gain at 0.5 Fs			-17.5		dB
Filter gain from 0.55 Fs to 64 Fs			-75		dB
Group delay			17/Fs		sec

ELECTRICAL CHARACTERISTICS (continued)

 At +25°C, AVDD1, AVDD2, DRVDD, IOVDD = 3.3 V, BVDD = 3.9 V, DVDD = 1.8 V, Int. V_{ref} = 2.5 V, Fs (Audio) = 48 kHz, unless otherwise noted (continued)

PARAMETER	TEST CONDITIONS	MIN	TYP	MAX	UNITS
MICROPHONE INPUT TO ADC					
	MICIN_HED 1020 Hz sine wave input, Fs = 48 ksps				
Full-scale input voltage (0 dB)			0.707		V _{rms}
Input common mode			1.5		V
SNR	Measured as idle channel noise, 0 dB gain, A-weighted	80	90		dBA
THD	0.63 V _{rms} input, 0-dB gain		-81	-72	dB
PSRR	217 Hz, 100 mV on AVDD1/2 ⁽¹⁾		55		dB
	1020 Hz, 100 mV on AVDD1/2 ⁽¹⁾		55		dB
Mute attenuation	Output code with 0.63 V _{rms} sine wave input at 1 kHz		0000H		
Input resistance	Only ADC on	15		50	kΩ
	ADC and Sidetone on	8		16	kΩ
Input capacitance			10		pF
HEADSET MICROPHONE BIAS					
Voltage range	Register 1DH/Page 2, D7–D8=00		3.3		V
	Register 1DH/Page 2, D7–D8=01		2.5		
	Register 1DH/Page 2, D7–D8=1X		2		
PSRR	217 Hz, 100 mV on AVDD1/2		55		dB
	217 Hz, 100 mV on BVDD		74		
	1020 Hz, 100 mV on AVDD1/2		55		
	1020 Hz, 100 mV on BVDD		74		
Sourcing current	Voltage drop <25 mV		5		mA
HANDSET MICROPHONE BIAS					
Voltage range	Register 1DH/Page 2, D6=0		2.5		V
	Register 1DH/Page 2, D6=1		2		
PSRR	217 Hz, 100 mV on AVDD1/2		55		dB
	1020 Hz, 100 mV on AVDD1/2		55		
Sourcing current	Voltage drop <25 mV		5		mA
DAC INTERPOLATION FILTER					
Pass band		20		0.45Fs	Hz
Pass band ripple			±0.06		dB
Transition band		0.45Fs		0.5501Fs	Hz
Stop band		0.5501Fs		7.455Fs	Hz
Stop band attenuation			65		dB
Filter group delay			21/Fs		Sec
De-emphasis error			±0.1		dB

(1) ADC PSRR measurement is calculated as:

$$PSRR = 20 \log_{10} \left(\frac{V_{SIG_{sup}}}{V_{ADCOUT}} \right)$$

 where V_{SIG_{sup}} is the ac signal applied on AVDD1/2, which is 100 mV_{PP} at 1020 Hz, and $V_{ADCOUT} = \frac{\text{Amplitude of Digital Output}}{\text{Max Possible Digital Amplitude}}$

ELECTRICAL CHARACTERISTICS (continued)

At +25°C, AVDD1, AVDD2, DRVDD, IOVDD = 3.3 V, BVDD = 3.9 V, DVDD = 1.8 V, V_{ref} = 2.5 V, F_s (Audio) = 48 kHz, unless otherwise noted (continued)

PARAMETER	TEST CONDITIONS	MIN	TYP	MAX	UNITS
DAC HEADPHONE OUTPUT					
	Load = 16 Ω (single-ended), 50 pF				
Full-scale output voltage (0dB)			0.848		V _{rms}
Output common mode			1.5		V
SNR	Measured as idle channel noise, A-weighted	85	95		dBA
THD	-1 dBFS Input, 0-dB gain		-80	-60	dB
PSRR	217 Hz, 100 mV on AVDD1/AVDD2/DRVDD ⁽¹⁾		55		dB
	1020 Hz, 100 mV on AVDD1/AVDD2/DRVDD ⁽¹⁾		55		dB
Interchannel isolation	Coupling from ADC to DAC		80		dB
Mute attenuation			100		dB
Maximum output power	Per channel		44		mW
Digital volume control		-63.5		0	dB
Digital volume control step size			0.5		dB
Channel separation	Between SPK1 and SPK2		-75		dB
DAC SPEAKER OUTPUT					
	Load = 8 Ω (differential), 50 pF				
Full-scale output voltage (0 dB)			1.838		V _{rms}
Output common mode			1.75		V
SNR	Measured as idle channel noise, A-weighted	90	98		dBA
THD	-1 dBFS Input, 0-dB gain		-74	-55	dB
PSRR	217 Hz, 100 mV on AVDD1/2		70		dB
	217 Hz, 100 mV on BVDD		70		
	1020 Hz, 100 mV on AVDD1/2		70		
	1020 Hz, 100 mV on BVDD		70		
Interchannel isolation	Coupling from ADC to DAC		90		dB
Mute attenuation			100		dB
Maximum output power			400		mW
CELLPHONE					
MIC INPUT TO CPOUT					
	1020-Hz Sine wave input on MICIN_HND, load on CP_OUT = 10 kΩ, 50 pF				
Full-scale input voltage (0 dB)			0.707		V _{rms}
Input common mode			1.5		V
Full-scale output voltage (0 dB)			0.707		V _{rms}
Output common mode			1.5		V
SNR	Measured as idle channel noise, A-weighted	80	89		dBA
THD	0 dBFS Input, 0-dB gain		-73	-60	dB
PSRR	217 Hz, 100 mV on AVDD1/AVDD2/DRVDD		43		dB
	1020 Hz, 100 mV on AVDD1/AVDD2/DRVDD		43		
Interchannel isolation	CP_IN to CP_OUT		75		dB
Mute attenuation	CP_OUT muted		100		dB

⁽¹⁾ DAC PSRR measurement is calculated as:

$$PSRR = 20 \log_{10} \left(\frac{V_{SIG_{sup}}}{V_{SPK1/2}} \right)$$

ELECTRICAL CHARACTERISTICS (continued)

 At +25°C, AVDD1, AVDD2, DRVDD, IOVDD = 3.3 V, BVDD = 3.9 V, DVDD = 1.8 V, V_{ref} = 2.5 V, Fs (Audio) = 48 kHz, unless otherwise noted (continued)

PARAMETER	TEST CONDITIONS	MIN	TYP	MAX	UNITS
CP_IN TO 32Ω RECEIVER (SPK1–OUT32N)	1020-Hz Sine wave input on CP_IN, Load on SPK1–OUT32N = 32 Ω (differential), 50 pF				
Full-scale input voltage (0 dB)			0.707		V _{rms}
Input common mode			1.5		V
Full-scale output voltage (0 dB)			1.697		V _{rms}
Output common mode			1.5		V
SNR	Measured as idle channel noise, A-weighted	85	97		dBA
THD	0 dBFs input, 0 dB gain		–77	–60	dB
PSRR	217 Hz, 100 mV on AVDD1/AVDD2/DRVDD		43		dB
	1020 Hz, 100 mV on AVDD1/AVDD2/DRVDD		43		
Interchannel isolation	MICIN to RECEIVER		75		dB
Mute attenuation			100		dB
Maximum output power			82		mW
DIGITAL INPUT/OUTPUT					
Logic family		CMOS			
Logic level: V _{IH}	I _{IH} = +5 μA	0.7IOVDD			V
V _{IL}	I _{IL} = +5 μA	–0.3	0.3IOVDD		V
V _{OH}	I _{OH} = 2 TTL loads	0.8IOVDD			V
V _{OL}	I _{OL} = 2 TTL loads	0.1IOVDD			V
Capacitive load			10		pF

ELECTRICAL CHARACTERISTICS (continued)

At +25°C, AVDD1, AVDD2, DRVDD, IOVDD = 3.3 V, BVDD = 3.9 V, DVDD = 1.8 V, V_{ref} = 2.5 V, Fs (Audio) = 48 kHz, unless otherwise noted (continued)

PARAMETER	TEST CONDITIONS	MIN	TYP	MAX	UNITS
POWER SUPPLY REQUIREMENTS					
Power supply voltage					
AVDD1, AVDD2		3	3.3	3.6	V
DRVDD		3	3.3	3.6	V
BVDD		3		4.2	V
IOVDD	Max MCLK = 100 MHz	2		3.6	V
	Max MCLK = 50 MHz	1.1		3.6	V
DVDD		1.65	1.8	1.95	V
Touch-screen ADC quiescent current	IAVDD1, host controlled AUX1 conversion at 10 ksps with external reference ⁽²⁾		67		μA
	IDVDD, host controlled AUX1 conversion at 10 ksps		82		
Analog supply current – audio play back only	IAVDD1 with loudspeaker output (no signal), PLL off		3.1		mA
	IBVDD with loudspeaker output (no signal), PLL off		7.5		
	IAVDD1 with headphone output (no signal), VGND off, PLL off		2.5		
	IDRVDD with headphone output (no signal), VGND off, PLL off		3.5		
Digital supply current – audio play back only	IDVDD, PLL off		2.5		mA
Analog supply current – mic record only ⁽¹⁾	IAVDD1, headset mic, PLL off		5.2		mA
	IBVDD, headset mic, PLL off		270		μA
	IAVDD1, handset mic, PLL off		5.6		mA
Digital supply current – mic record only	IDVDD, PLL off		1.4		mA
Analog supply current	IAVDD2, PLL on		1.3		mA
Digital supply current	IDVDD, PLL on		0.9		mA
Total current ⁽²⁾	Hardware power down		27		μA
	Only headset/button detection enabled		50		
	Only auto temperature measurement with 5.59 min delay		50		
	Headset/button detection and auto temperature measurement with 5.59 min delay		65		
Default current ⁽³⁾	IAVDD1 + IAVDD2		66		μA
	IBVDD		9		

⁽¹⁾ Mic record currents measured with no load on MICBIAS.

⁽²⁾ Current measured with MICBIAS_HED voltage programmed to 2 V (Page 2, Register 1DH, Bit D8=1).

⁽³⁾ Default currents measured with device in default mode after reset.

FUNCTIONAL BLOCK DIAGRAM

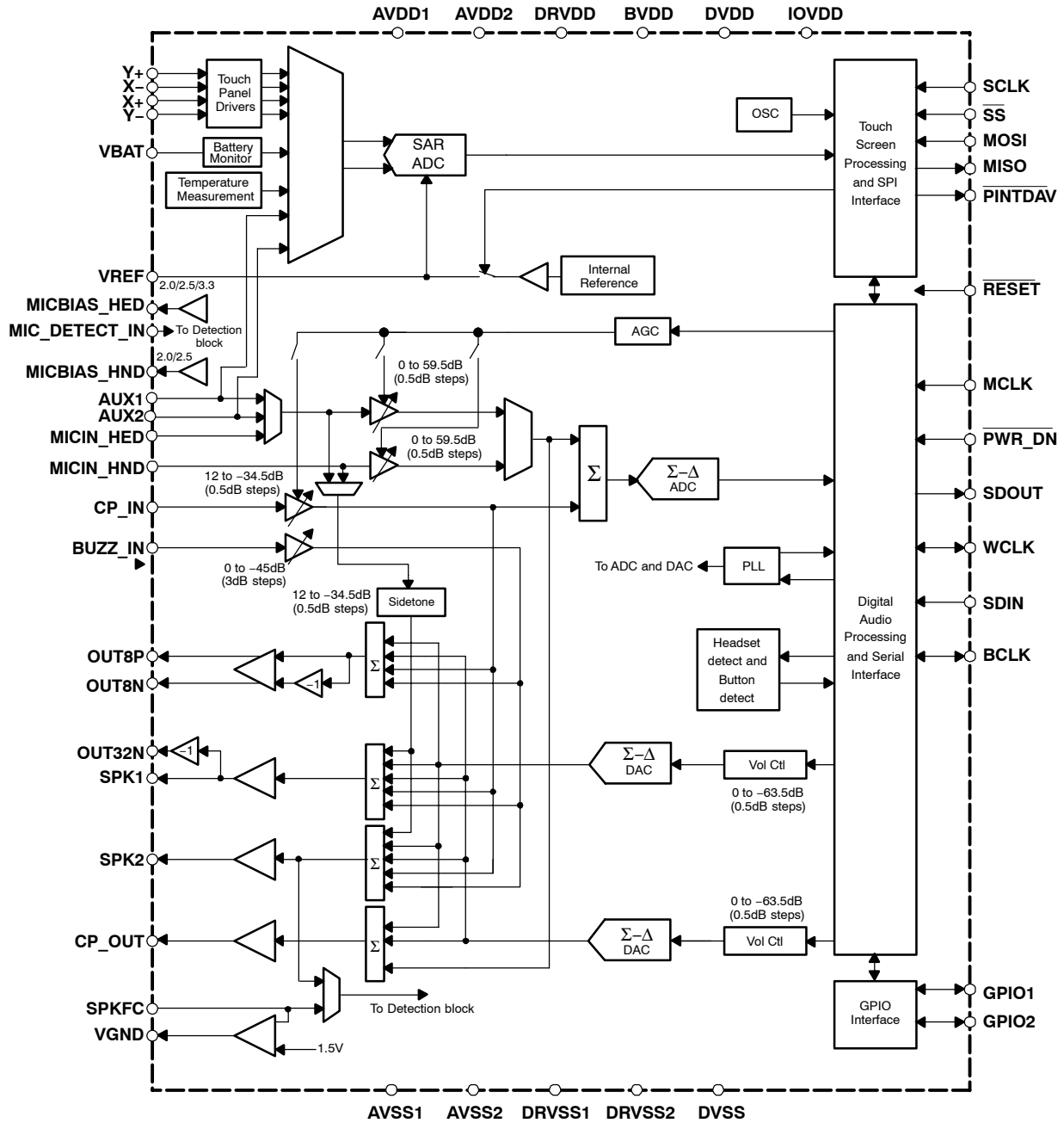

SPI TIMING DIAGRAM

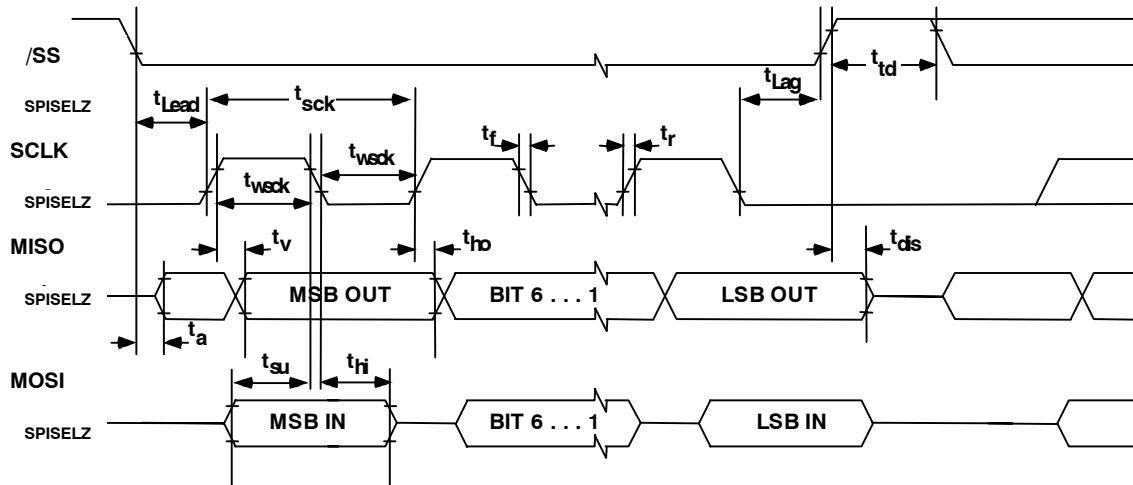

TYPICAL TIMING REQUIREMENTS

All specifications typical at 25°C, DVDD = 1.8 V(1)

PARAMETER	IOVDD = 1.1 V		IOVDD = 3.3 V		UNITS
	MIN	MAX	MIN	MAX	
$t_{w_{sck}}$ SCLK Pulse width	30		18		ns
t_{Lead} Enable Lead Time	18		15		ns
t_{Lag} Enable Lag Time	18		15		ns
t_{td} Sequential Transfer Delay	18		15		ns
t_a Slave MISO access time		18		15	ns
t_{dis} Slave MISO disable time		18		15	ns
t_{su} MOSI data setup time	6		6		ns
t_{hi} MOSI data hold time	6		6		ns
t_{ho} MISO data hold time	4		4		ns
t_v MISO data valid time		25		13	ns
t_r Rise Time		6		4	ns
t_f Fall Time		6		4	ns

(1) These parameters are based on characterization and are not tested in production.

AUDIO INTERFACE TIMING DIAGRAMS

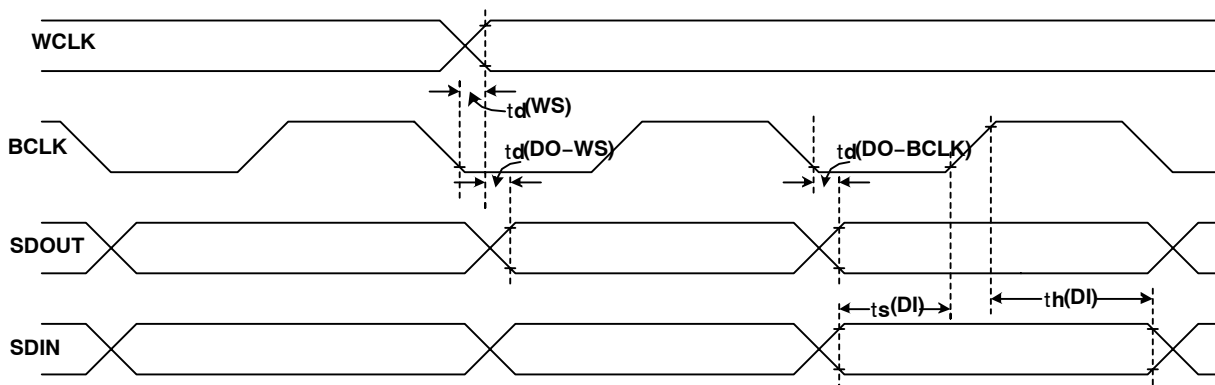

Figure 1. I2S/LJ/RJ in Master Mode

Typical Timing Requirements (see Figure 1)

PARAMETER ⁽¹⁾	IOVDD = 1.1 V		IOVDD = 3.3 V		UNITS
	MIN	MAX	MIN	MAX	
$t_d(\text{WS})$ WCLK delay		30		15	ns
$t_d(\text{DO-WS})$ WCLK to DOUT delay (for LJF mode)		30		15	ns
$t_d(\text{DO-BCLK})$ BCLK to DOUT delay		30		15	ns
$t_s(\text{DI})$ SDIN setup	6		6		ns
$t_h(\text{DI})$ SDIN hold	6		6		ns
t_r Rise time		18		6	ns
t_f Fall time		18		6	ns

(1) These parameters are based on characterization and are not tested in production.

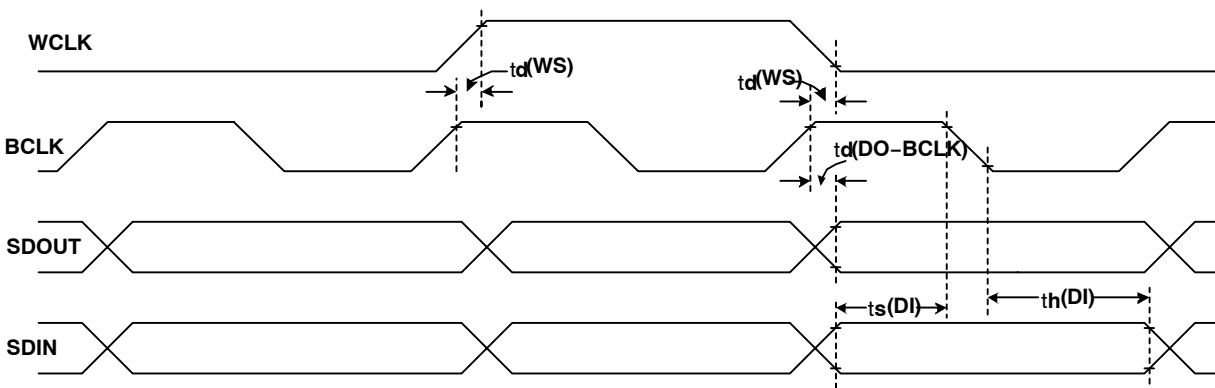

Figure 2. DSP Timing in Master Mode

Typical Timing Requirements (see Figure 2)

PARAMETER ⁽¹⁾	IOVDD = 1.1 V		IOVDD = 3.3 V		UNITS
	MIN	MAX	MIN	MAX	
$t_d(\text{WS})$ WCLK delay		30		15	ns
$t_d(\text{DO-BCLK})$ BCLK to DOUT delay		30		15	ns
$t_s(\text{DI})$ SDIN setup	6		6		ns
$t_h(\text{DI})$ SDIN hold	6		6		ns
t_r Rise time		18		6	ns
t_f Fall time		18		6	ns

(1) These parameters are based on characterization and are not tested in production.

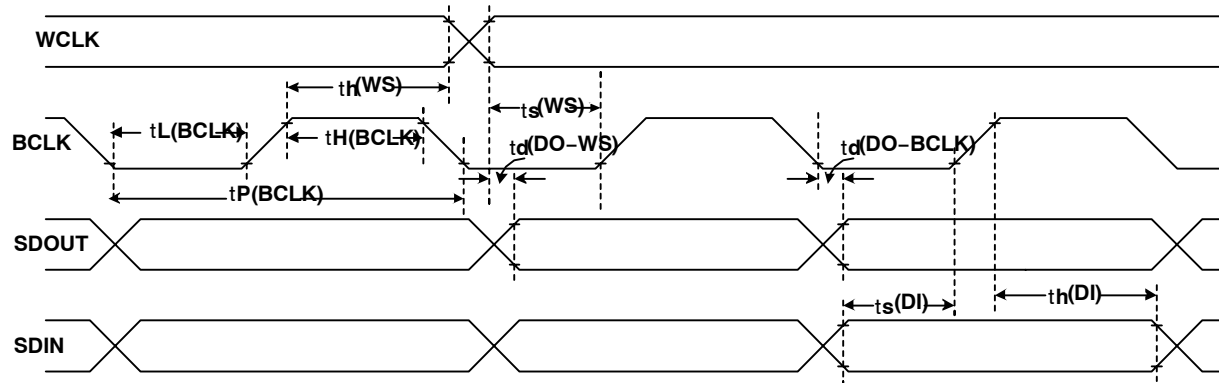

Figure 3. I²S/LJF/RJF Timing in Slave Mode

Typical Timing Requirements (see Figure 3)

PARAMETER ⁽¹⁾		IOVDD = 1.1 V		IOVDD = 3.3 V		UNITS
		MIN	MAX	MIN	MAX	
t _H (BCLK)	BCLK high period	40		35		ns
t _L (BCLK)	BCLK low period	40		35		ns
t _s (WS)	WCLK setup	6		6		ns
t _h (WS)	WCLK hold	6		6		ns
t _d (DO-WS)	WCLK to DOUT delay (for LJF mode)		30		18	ns
t _d (DO-BCLK)	BCLK to DOUT delay		30		15	ns
t _s (DI)	SDIN setup	6		6		ns
t _h (DI)	SDIN hold	6		6		ns
t _r	Rise time		5		4	ns
t _f	Fall time		5		4	ns

(1) These parameters are based on characterization and are not tested in production.

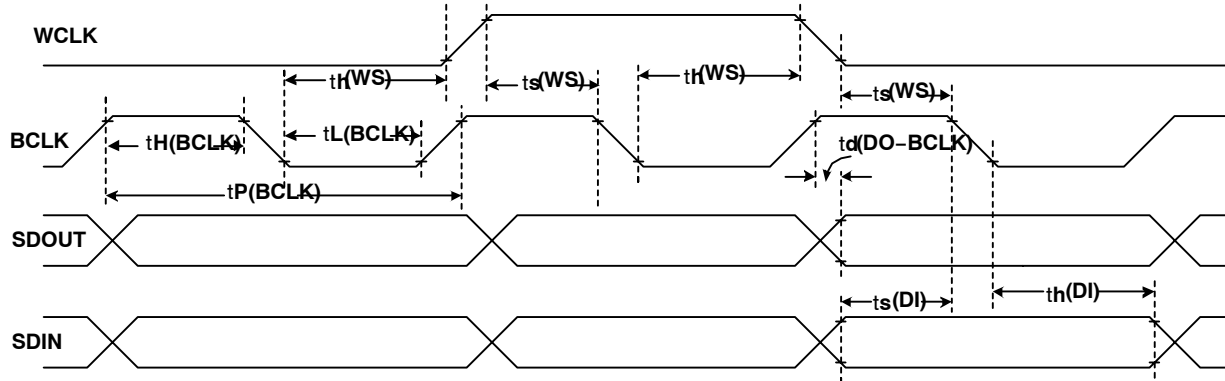

Figure 4. DSP Timing in Slave Mode

Typical Timing Requirements (see Figure 4)

PARAMETER ⁽¹⁾		IOVDD = 1.1 V		IOVDD = 3.3 V		UNITS
		MIN	MAX	MIN	MAX	
$t_H(\text{BCLK})$	BCLK high period	40		35		ns
$t_L(\text{BCLK})$	BCLK low period	40		35		ns
$t_P(\text{BCLK})$	BCLK period	80		80		ns
$t_S(\text{WS})$	WCLK setup	6		6		ns
$t_H(\text{WS})$	WCLK hold	6		6		ns
$t_d(\text{DO-BCLK})$	BCLK to DOUT delay		30		15	ns
$t_S(\text{DI})$	SDIN setup	6		6		ns
$t_H(\text{DI})$	SDIN hold	6		6		ns
t_r	Rise time		5		4	ns
t_f	Fall time		5		4	ns

⁽¹⁾ These parameters are based on characterization and are not tested in production.

TYPICAL CHARACTERISTICS

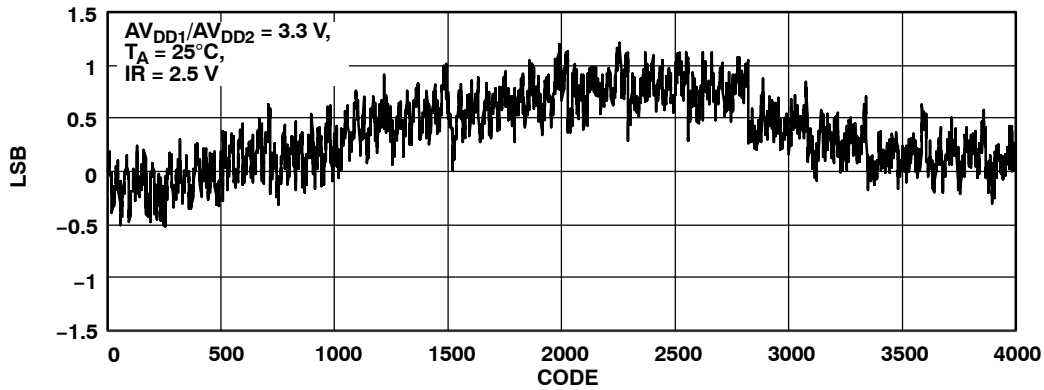

Figure 5. SAR INL ($T_A = 25^\circ\text{C}$, Internal Reference = 2.5 V, 12 bit, $AV_{DD1}/AV_{DD2} = 3.3\text{ V}$)

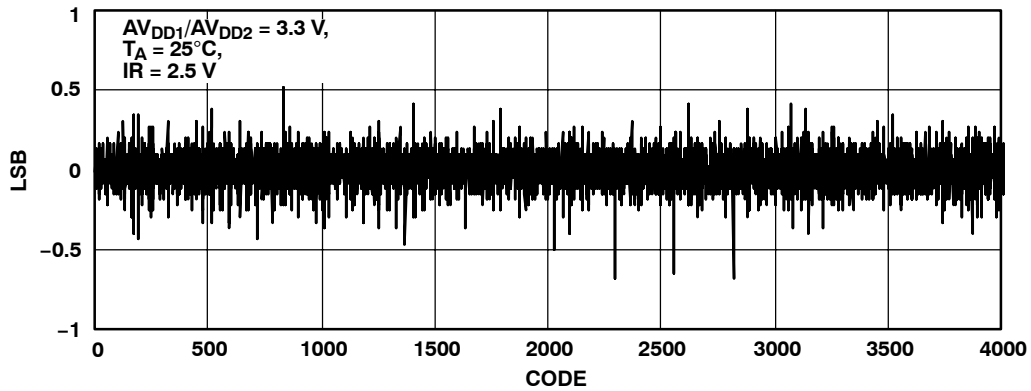

Figure 6. SAR DNL ($T_A = 25^\circ\text{C}$, Internal Reference = 2.5 V, 12 bit, $AV_{DD1}/AV_{DD2} = 3.3\text{ V}$)

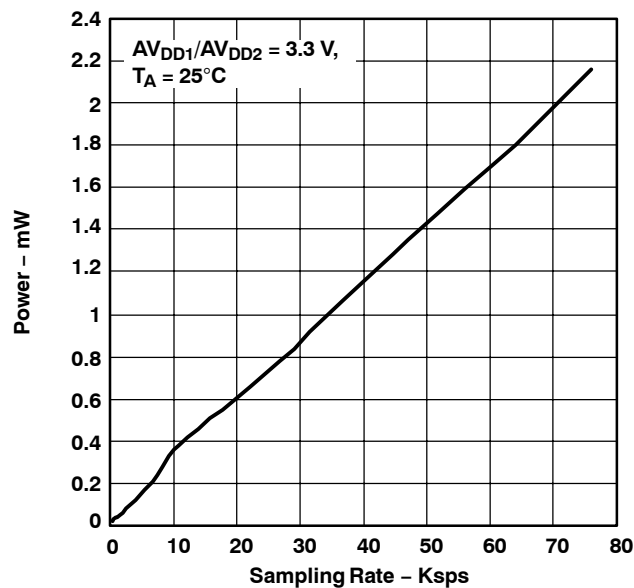

Figure 7. SAR ADC Power Consumption vs Speed ($T_A = 25^\circ\text{C}$, External Reference, Host Controlled AUX Conversion, $AV_{DD1}/AV_{DD2} = 3.3\text{ V}$)

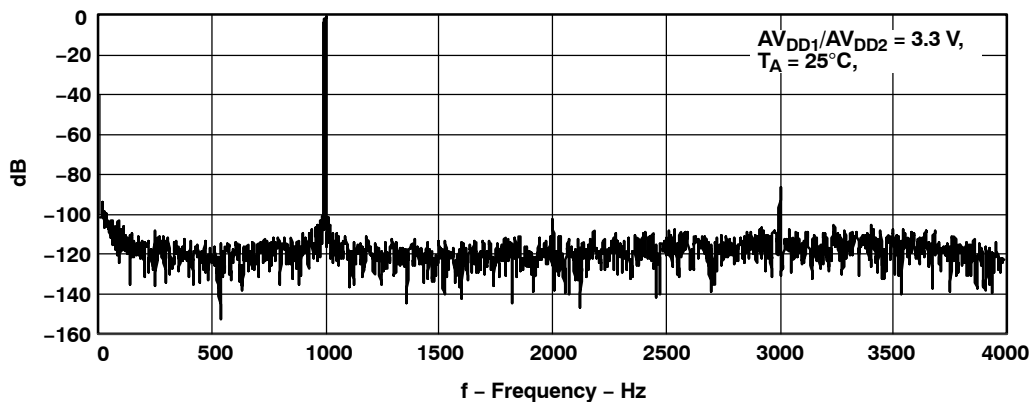

Figure 8. ADC FFT Plot at 8 ksps ($T_A = 25^\circ\text{C}$, -1 dB, 1 kHz input, $AV_{DD1}/AV_{DD2} = 3.3 \text{ V}$)

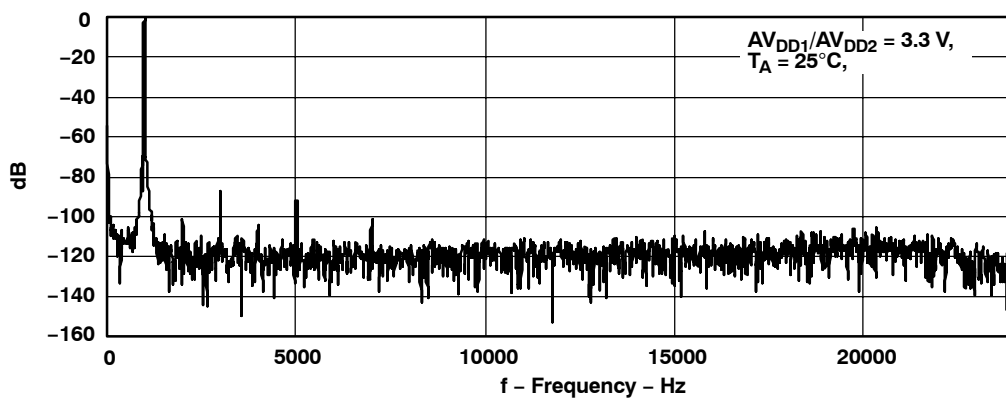

Figure 9. ADC FFT Plot at 48 ksps ($T_A = 25^\circ\text{C}$, -1 dB, 1 kHz input, $AV_{DD1}/AV_{DD2} = 3.3 \text{ V}$)

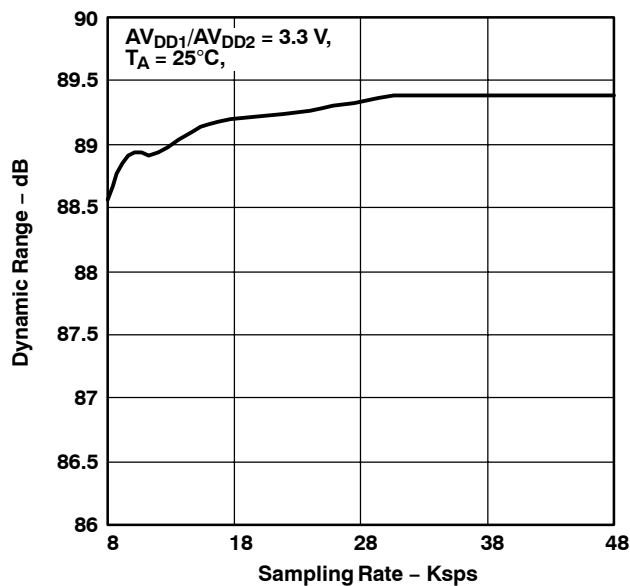

Figure 10. ADC Dynamic Range vs Sampling Rate ($T_A = 25^\circ\text{C}$, $AV_{DD1}/AV_{DD2} = 3.3 \text{ V}$)

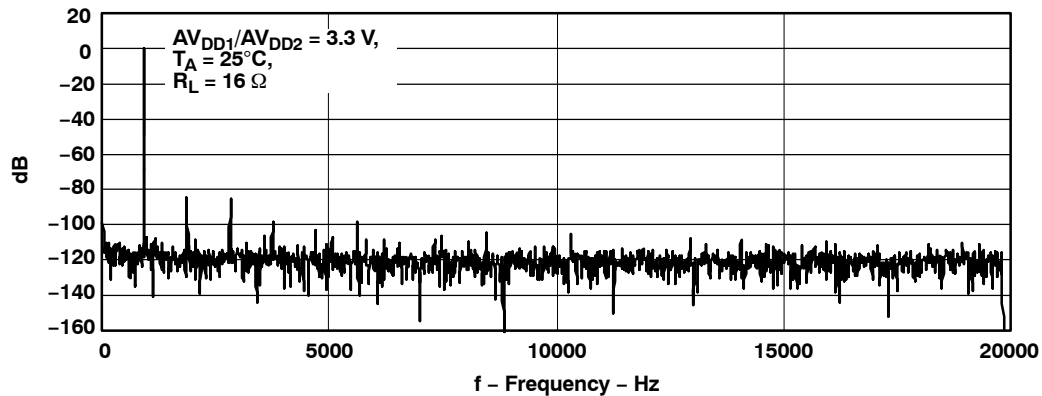

Figure 11. DAC FFT Plot (T_A = 25°C, -1 dB, 1 kHz Input, AV_{DD1}/AV_{DD2}/DRV_{DD} = 3.3 V, R_L = 16 Ω)

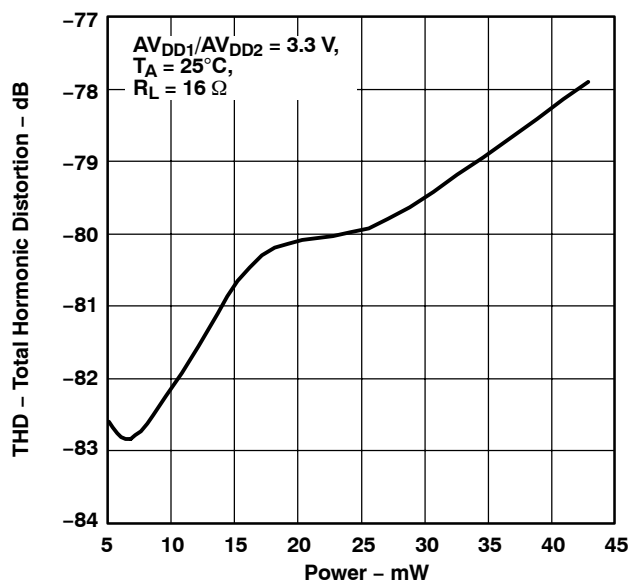

Figure 12. THD vs Power on SPK1/2 (T_A = 25°C, 1 kHz Input, AV_{DD1}/AV_{DD2}/DRV_{DD} = 3.3 V, R_L = 16 Ω)

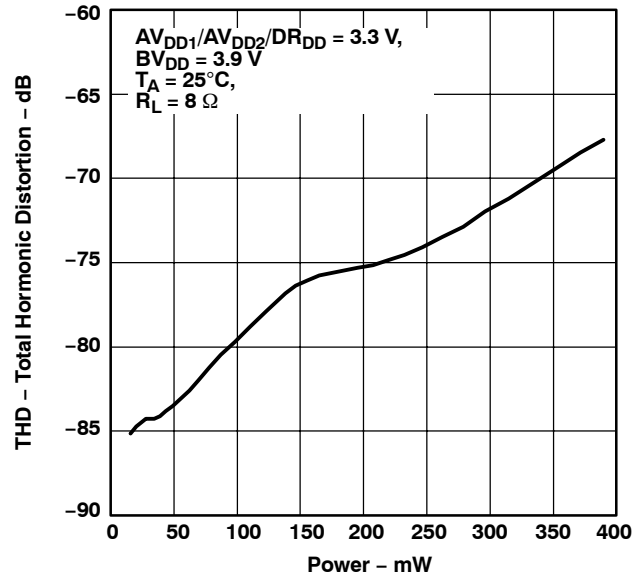

Figure 13. THD vs Power on Loudspeaker Driver ($T_A = 25^\circ\text{C}$, 1 kHz Input, $AV_{DD1}/AV_{DD2}/DR_{DD} = 3.3 \text{ V}$, $BV_{DD} = 3.9 \text{ V}$, $R_L = 8 \Omega$)

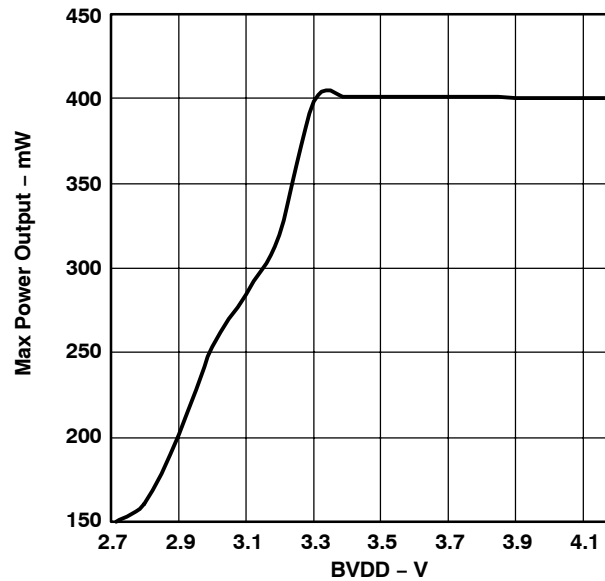

Figure 14. Loudspeaker Driver Output Power vs BV_{DD} ($T_A = 25^\circ\text{C}$, 1 kHz Input, $AV_{DD1}/AV_{DD2}/DR_{DD} = 3.3 \text{ V}$, $R_L = 8 \Omega$, $THD \leq -40 \text{ dB}$)

OVERVIEW

The TSC2101 is a highly integrated stereo audio DAC and mono audio ADC with touch screen controller for portable computing, communication and entertainment applications. A register-based architecture eases integration with microprocessor-based systems through a standard SPI bus. All peripheral functions are controlled through the registers and on-board state machines.

The TSC2101 consists of the following blocks:

- Audio Codec
- Headset and Button Detection
- Touch Screen Interface
- Battery Monitors
- Auxiliary Inputs
- Temperature Monitor

Communication to the TSC2101 is via a standard SPI serial interface. This interface requires that the Slave Select signal (\overline{SS}) be driven low to communicate with the TSC2101. Data is then shifted into or out of the TSC2101 under control of the host microprocessor, which also provides the serial data clock.

Control of the TSC2101 and its functions is accomplished by writing to different registers in the TSC2101. A simple command protocol is used to address the 16-bit registers. Registers control the operation of the SAR ADC and audio codec.

OPERATION—AUDIO CODEC

AUDIO ANALOG I/O

The TSC2101 has stereo audio DAC and mono audio ADC. It supports a wide range of analog interface to support different headsets and analog outputs. The TSC2101 has features to interface output drivers (8- Ω , 16- Ω , 32- Ω) and Microphone PGA to Cell-phone. The TSC2101 also has a virtual ground (VGND) output, which can be optionally used to connect to the ground terminal of a speaker or headphone to eliminate the ac-coupling capacitor needed at the speaker or headphone output. A special circuit has also been included in the TSC2101 to insert a short keyclick sound into the stereo audio output, even when the audio DAC is powered down. The keyclick sound is used to provide feedback to the user when a particular button is pressed or item is selected. The specific sound of the keyclick can be adjusted by varying several register bits that control its frequency, duration, and amplitude.

AUDIO DIGITAL I/O INTERFACE

Digital audio data samples can be transmitted between the TSC2101 and the CPU via the serial bus (BCLK, WCLK, SDOUT, SDIN) that can be configured to transfer digital data in four different formats: Right justified (RJF), Left justified (LJF), I²S and DSP. The four modes are MSB first and operate with variable word length between 16/20/24/32 bits. The TSC2101's audio codec can operate in master or slave mode, depending on the setting of D11 at the register 06h of page 2. The word-select signal (WCLK) and bit clock signal (BCLK) are configured as inputs when the bus is in slave mode (D11 = 0). They are configured as outputs when the bus is in master mode (D11 = 1). Under master mode, both clocks start running when the I²S bus needs to be active (one of the analog input/output paths has been configured and powered up). The WCLK is representative of the sampling rate of the audio ADC/DAC and is synchronized with SDOUT. Although the SDOUT signal can contain two channels of information (a left and right channel), the TSC2101 sends the same ADC data in both channels.

- **ADC/DAC Sampling Rate**

The audio-control-1 register (Register 00H, Page 2) determines the sampling rates of DAC and ADC. The sampling frequency is scaled down from the reference rate (Fsref). The reference rate is usually either 44.1 kHz or 48 kHz which can be selectable using bit D13 of the register Audio Control 3 (06H/Page2). The ADC and DAC can operate with either common WCLK (equal sampling rates) or separate GPIO1 (For ADC) and WCLK (For DAC) for unequal sampling rates. When the audio codec is powered up, it is by default configured as an I²S slave with both the DAC and ADC operating at Fsref.

- **Word Select Signals**

The word select signal (WCLK) indicates the channel being transmitted:

- WCLK = 0: left channel for I²S mode;
- WCLK = 1: right channel for I²S mode.

For other modes refer to the timing diagrams below.

- **Bitclock (BCLK) Signal**

In addition to being programmable as master or slave mode, the BCLK can also be configured in two transfer modes, 256-S transfer mode and continuous transfer mode, which are described below. These modes are set using bit D12 of control register 06H/page 2.

- **256-S Transfer Mode**

In the 256-S mode, the BCLK rate always equals 256 times the WCLK frequency. In the 256-S mode, the combination of ADC/DAC sampling rate equal to F_{sref} (as selected by bit D5D0 of control register 00H/page 2) and left-justified mode is not supported. If IOVDD is equal to 1.1 V, then ADC/DAC sampling rate should be less than 39 kHz for all modes except the left justified mode where it should be less than 24 kHz.

- **Continuous Transfer Mode**

In the continuous transfer mode, the BCLK rate always equals two-word length times the frequency of WCLK.

- **Right Justified Mode**

In right-justified mode, the LSB of left channel is valid on the rising edge of BCLK preceding, the falling edge on WCLK. Similarly the LSB of right channel is valid on the rising edge of BCLK preceding the rising edge of WCLK.

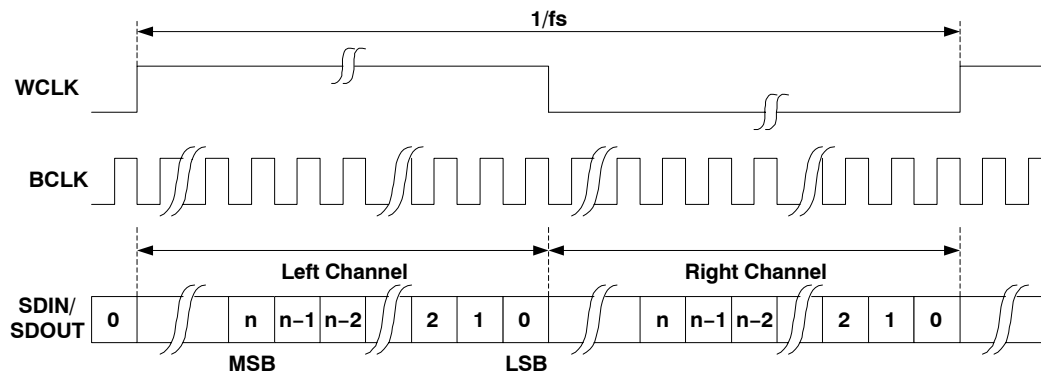

Figure 15. Timing Diagram for Right-Justified Mode

● **Left Justified Mode**

In left-justified mode, the MSB of right channel is valid on the rising edge of BCLK, following the falling edge on WCLK. Similarly the MSB of left channel is valid on the rising edge of BCLK following the rising edge of WCLK.

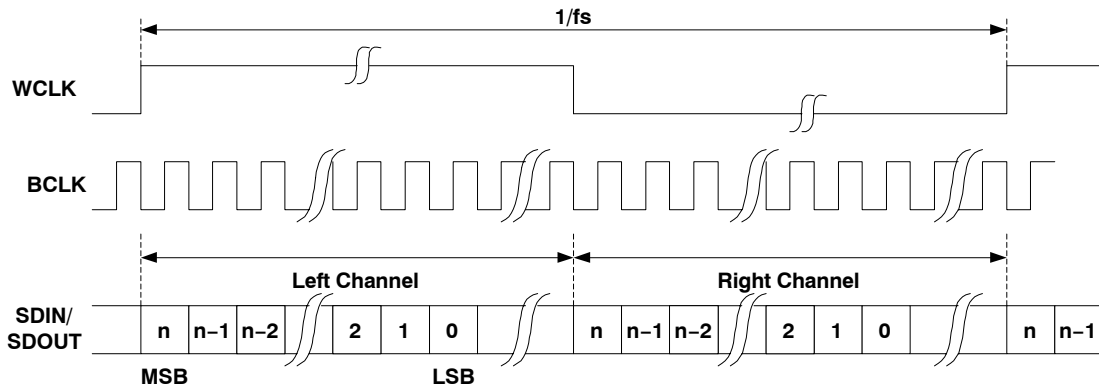

Figure 16. Timing Diagram for Left-Justified Mode

● **I²S Mode**

In I²S mode, the MSB of left channel is valid on the second rising edge of BCLK, after the falling edge on WCLK. Similarly the MSB of right channel is valid on the second rising edge of BCLK, after the rising edge of WCLK.

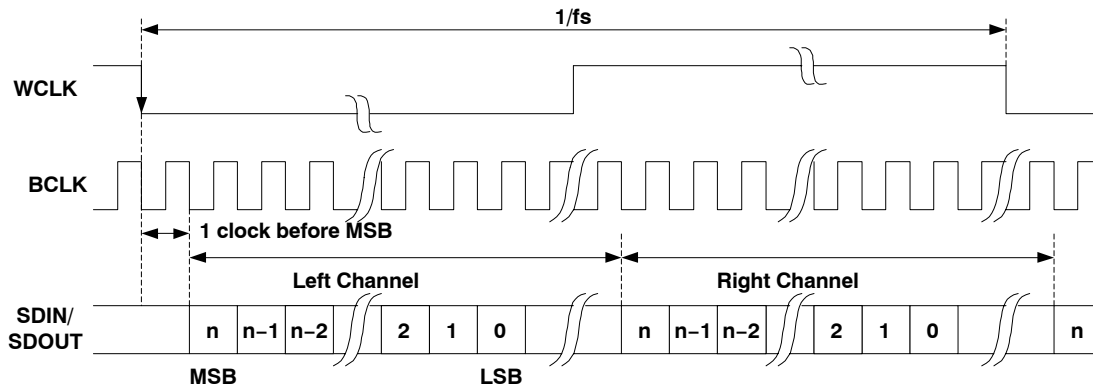

Figure 17. Timing Diagram for I2S Mode

● **DSP Mode**

In DSP mode, the falling edge of WCLK starts the data transfer with the left channel data first and immediately followed by the right channel data. Each data bit is valid on the falling edge of BCLK.

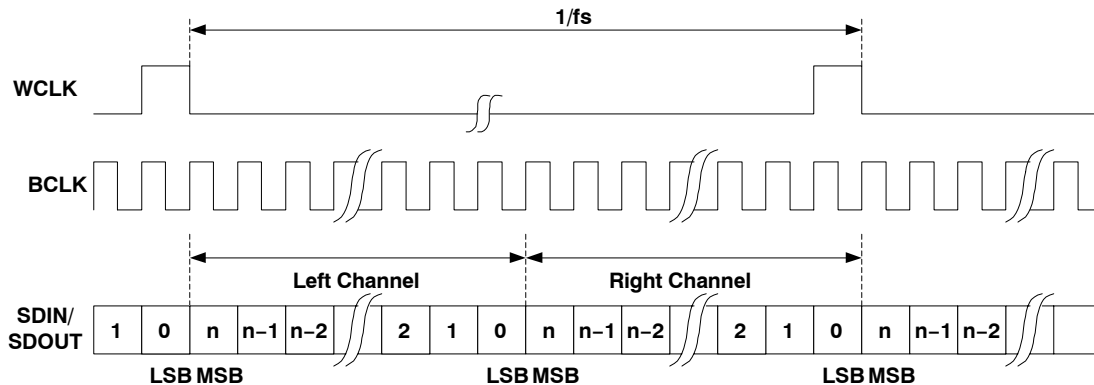

Figure 18. Timing Diagram for DSP Mode

AUDIO DATA CONVERTERS

The TSC2101 includes a stereo audio DAC and a mono audio ADC. Both ADC and DAC can operate with a maximum sampling rate of 53 kHz and support all audio standard rates of 8 kHz, 11.025 kHz, 12 kHz, 16 kHz, 22.05 kHz, 24 kHz, 32 kHz, 44.1 kHz, and 48 kHz. By utilizing the flexible clock generation capability and internal programmable interpolation, a wide variety of sampling rates up to 53 kHz can be obtained from many possible MCLK inputs. In addition, the DAC and ADC can independently operate at different sampling rates as indicated in control register 00H/page 2.

When the ADC or DAC is operating, the TSC2101 requires an applied audio MCLK input. The user should also set bit D13 of control register 06H/page 2 to indicate which Fsref rate is being used. If the codec ADC or DAC is powered up, then the touch screen ADC uses MCLK and BCLK for its internal clocking, and the internal oscillator is powered down to save power.

Typical audio DACs can suffer from poor out-of-band noise performance when operated at low sampling rates, such as 8 kHz or 11.025 kHz. The TSC2101 includes programmable interpolation circuitry to provide improved audio performance at such low sampling rates, by first upsampling low-rate data to a higher rate, filtering to reduce audible images, and then passing the data to the internal DAC, which is actually operating at the Fsref rate. This programmable interpolation is determined using bit D5D3 of control register 00H/page 2.

For example, if playback of 11.025 kHz data is required, the TSC2101 can be configured such that Fsref = 44.1 kHz. Then using bit D5D3 of control register/page 2, the DAC sampling rate (Fs) can be set to Fsref/4, or FS = 11.025 kHz. In operation, the 11.025 kHz digital input data is received by the TSC2101, upsampled to 44.1 kHz, and filtered for images. It is then provided to the audio DAC operating at 44.1 kHz for playback. In reality, the audio DAC further upsamples the 44.1 kHz data by a ratio of 128 x and performs extensive interpolation filtering and processing on this data before conversion to a stereo analog output signal.

Phase Locked Loop (PLL)

The TSC2101 has an on chip PLL to generate the needed internal ADC and DAC operational clocks from a wide variety of clocks that may be available in the system. The PLL supports an MCLK varying from 2 MHz to 100 MHz and is register programmable to enable generation of required sampling rates with fine precision.

ADC and DAC sampling rates are given by

$$\text{DAC}_{Fs} = \frac{Fsref}{N1}$$

and

$$\text{ADC}_{Fs} = \frac{Fsref}{N2}$$

Where, Fsref must fall between 39 kHz and 53 kHz, and N1, N2=1, 1.5, 2, 3, 4, 5, 5.5, 6 are register programmable.

The PLL can be enabled or disabled using register programming.

- When PLL is disabled

$$Fsref = \frac{MCLK}{128 \times Q}$$

$$Q = 2, 3 \dots 17$$

— Note: For ADC, with N2 = 1.5 or 5.5, odd values of Q are not allowed.

— In this mode, the MCLK can operate up to 100 MHz, and Fsref should fall between 39 kHz and 53 kHz.

- When PLL is enabled

$$F_{\text{sref}} = \frac{\text{MCLK} \times K}{2048 \times P}$$

$$P = 1, 2, 3 \dots 8$$

$$K = J.D$$

$$J = 1, 2, 3 \dots 64$$

$$D = 0, 1, 2 \dots 9999$$

P, J and D are register programmable. where J is integer part of K before the decimal point, and D is four-digit fractional part of K after the decimal point, including lagging zeros.

Examples: If K = 8.5, then J = 8, D = 5000

If K = 7.12, then J = 7, D = 1200

If K = 7.012, then J = 7, D = 120

The PLL is programmed through Registers 1BH and 1CH of Page 2.

- When PLL is enabled and D = 0, the following conditions must be satisfied

$$2 \text{ MHz} \leq \frac{\text{MCLK}}{P} \leq 20 \text{ MHz}$$

$$80 \text{ MHz} \leq \frac{\text{MCLK} \times K}{P} \leq 110 \text{ MHz}$$

$$4 \leq J \leq 55$$

- When PLL is enabled D ≠ 0, the following conditions must be satisfied

$$10 \text{ MHz} \leq \frac{\text{MCLK}}{P} \leq 20 \text{ MHz}$$

$$80 \text{ MHz} \leq \frac{\text{MCLK} \times K}{P} \leq 110 \text{ MHz}$$

$$4 \leq J \leq 11$$

Example 1:

For MCLK = 12 MHz and Fsref = 44.1 kHz

P = 1, K = 7.5264

J = 7, D = 5264

Example 2:

For MCLK = 12 MHz and Fsref = 48 kHz

P = 1, K = 8.192

J = 8, D = 1920

To externally observe the PLL function, the GPIO2 pin can be set up as the clock monitor (set D2 = 1, register 22h, page 2). Note that besides setting up the PLL and GPIO2, the audio ADC or DAC must be enabled for the PLL output to appear at the GPIO2.

Example 1:

- Start from power up (with the proper sequence)
- Make sure MCLK is provided and /PWR_DWN and /RESET are both high
- Set and enable PLL
- Connect and power up (do not unmute anything) ADC or DAC or both, for instance:
 - Page2/Reg03h to C530h or C510h (default is C500h) to connect MICSEL to ADC
 - Page2/Reg05h to FDFCh (default is FFFCh) to power up ADC.
- Set Page2/Reg22h to 0004h to output PLL to GPIO2 pin.

MONO AUDIO ADC

Analog Front End

The analog front end of the audio ADC consists of an analog MUX and a programmable gain amplifier (PGA). The MUX can connect either of the Headset Input (MICIN_HED), Handset Input (MICIN_HND), AUX1 and AUX2 signal through the PGA to the ADC for audio recording. The Cell-phone Input (CP_IN) can also be connected to ADC through a PGA at the same time. This enables recording of conversation during a cell-phone call. The TSC2101 also has an option of choosing MICIN_HED/MICIN_HND and AUX1/AUX2 as differential input pair. The TSC2101 also includes two microphone bias circuits which can source up to 5 mA of current, and are programmable to a 2 V, 2.5 V or 3.3 V level for Headset and 2 V or 3.3 V level for handset.

Because of the oversampling nature of the audio ADC and the integrated digital decimation filtering, requirements for analog anti-aliasing filtering are very relaxed. The TSC2101 integrates a second order analog anti-aliasing filter with 20-dB attenuation at 1 MHz. This filter, combined with the digital decimation filter, provides sufficient anti-aliasing filtering without requiring any external components.

The PGA, for microphone and AUX Inputs, allows analog gain control from 0 dB to 59.5 dB in steps of 0.5 dB. The PGA gain changes are implemented with an internal soft-stepping. This soft-stepping ensures that volume control changes occur smoothly with no audible artifacts. Upon reset, the PGA gain defaults to a mute condition, and upon power down, the PGA soft-steps the volume to mute before shutting down. A read-only flag (D0 control register 04H/Page 2) is set whenever the gain applied by PGA equals the desired value set by the register. The soft-stepping control can be disabled by programming D15=1 in register 1DH of Page 2. When soft stepping is enabled and ADC power down register is written, MCLK should be running to ensure that soft-stepping to mute has completed. MCLK can be shut down once Mic PGA power down flag is set.

The PGA, for Cell phone Input (CP_IN) allows gain control from –34.5 dB to 12 dB in steps of 0.5 dB. The PGA gain changes are implemented with an internal soft-stepping. This soft-stepping ensures that volume control changes occur smoothly with no audible artifacts. Upon reset, the PGA gain defaults to a mute condition, and upon power down, the PGA soft-steps the volume to mute before shutting down. A read-only flag (D7 control register 1FH/Page 2) is set whenever the gain applied by PGA equals the desired value set by the register. The soft-stepping control can be disabled by the programming D12=1 in register 1DH of Page 2. When soft-stepping is enabled and ADC power down register is written, MCLK should be running to ensure that soft-stepping to mute has completed. MCLK can be shut down once Cell PGA power down flag is set.

Delta-Sigma ADC

The analog-to-digital converter has a delta-sigma modulator with a 128 times oversampling ratio. The ADC can support maximum output rate of 53 kHz.

Decimation Filter

The audio ADC includes an integrated digital decimation filter that removes high frequency content and downsamples the audio data from an initial sampling rate of 128 times F_s to the final output sampling rate of F_s . The decimation filter provides a linear phase output response with a group delay of $17/F_s$. The –3 dB bandwidth of the decimation filter extends to $0.45 F_s$ and scales with the sample rate (F_s).

Programmable High Pass Filter

The ADC channel has a programmable high-pass filter whose cutoff frequency can be programmed through control register. By default the high pass filter is off. The high-pass filter is a first order IIR filter. This filter can be used to remove the DC component of the input signal and offset of the ADC channel.

Automatic Gain Control (AGC)

The TSC2101 includes Automatic gain control (AGC) for Microphone Inputs (MICIN_HED or MICIN_HND) and Cell-phone input (CP_IN). AGC can be used to maintain nominally constant output signal amplitude when recording speech signals. This circuitry automatically adjusts the PGA gain as the input signal becomes overly loud or very weak, such as when a person speaking into a microphone moves closer or farther from the microphone. The AGC algorithm has several programmable settings, including target gain, attack and decay time constants, noise threshold, and max PGA applicable that allow the algorithm to be fine tuned for any particular application. The algorithm uses the absolute average of the signal (which is the average of the absolute value of the signal) as a measure of the nominal amplitude of the output signal.

Target gain represents the nominal output level at which the AGC attempts to hold the ADC output signal level. The TSC2101 allows programming of eight different target gains, which can be programmed from -5.5 dB to -24 dB relative to a full-scale signal. Since the TSC2101 reacts to the signal absolute average and not to peak levels, it is recommended that the target gain be set with enough margin to avoid clipping at the occurrence of loud sounds.

Attack time determines how quickly the AGC circuitry reduces the PGA gain when the input signal is too loud. It can be varied from 8 ms to 20 ms.

Decay time determines how quickly the PGA gain is increased when the input signal is too low. It can be varied in the range from 100 ms to 500 ms.

Noise threshold determines level below which if the input speech average value falls, AGC considers it as a silence and hence brings down the gain to 0 dB in steps of 0.5 dB every FS and sets noise threshold flag. The gain stays at 0 dB unless the input speech signal average rises above noise threshold setting. This ensures that noise does not get gained up in the absence of speech. Noise threshold level in the AGC algorithm is programmable from -30 dB to -90 dB for microphone input, and from -30 dB to -60 dB for cell-phone input. When AGC Noise Threshold is set to -70 dB, -80 dB, or -90 dB, the microphone input Max PGA applicable setting must be greater than or equal to 11.5 dB, 21.5 dB, or 31.5 dB respectively. This operation includes debounce and hysteresis to avoid the AGC gain from cycling between high gain and 0 dB when signals are near the noise threshold level. When noise threshold flag is set, status of gain applied by AGC and saturation flag should be ignored.

Max PGA applicable allows user to restrict maximum gain applied by AGC. This can be used for limiting PGA gain in situations where environment noise is greater than programmed noise threshold. Microphone input Max PGA can be programmed from 0 dB to 59.5 dB in steps of 0.5 dB. Cell-phone input Max PGA can be programmed from -34.5 dB to -0.5 dB in steps of 0.5 dB, as well as $+12$ dB.

See Table 1 for various AGC programming options. AGC can be used only if microphone input or Cell-phone input is routed to the ADC channel. When both microphone input and Cell-phone input are connected to the ADC, AGC is automatically disabled.

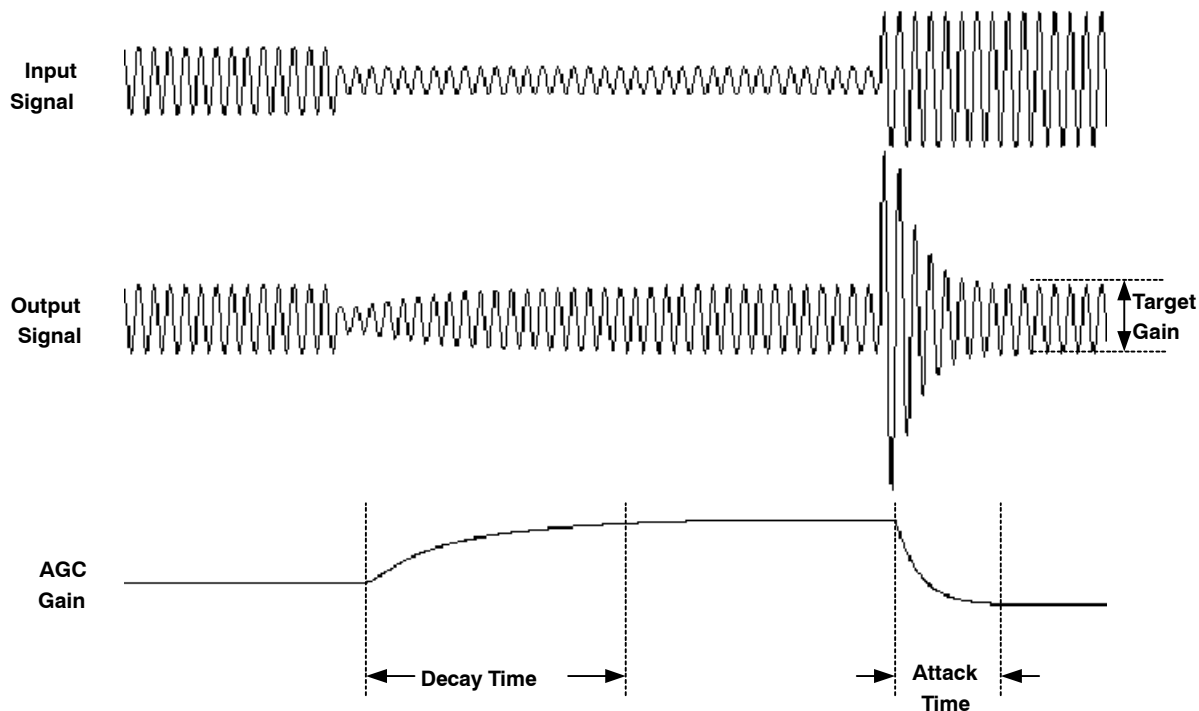

Figure 19. AGC Characteristics

Table 1. AGC Settings

	MIC HEADSET INPUT		MIC HANDSET INPUT		CELL-PHONE INPUT	
	BIT	CONTROL REGISTER	BIT	CONTROL REGISTER	BIT	CONTROL REGISTER
AGC enable	D0	01H	D0	1EH	D0	24H
Target gain	D7–D5	01H	D7–D5	1EH	D7–D5	24H
Time constants (attack and decay time)	D4–D1	01H	D4–D1	1EH	D4–D1	24H
Noise threshold	D13–D11	24H	D13–D11	24H	D13–D11	24H
Noise threshold flag	D11	04H	D11	04H	D14	24H
Hysteresis	D10–D9	1DH	D10–D9	1DH	D10–D9	24H
Debounce time (normal to silence mode)	D8–D6	26H	D8–D6	26H	D8–D6	27H
Debounce time (silence to normal mode)	D5–D3	26H	D5–D3	26H	D5–D3	27H
Max PGA applicable	D15–D9	26H	D15–D9	26H	D15–D9	27H
Gain applied by AGC	D15–D8	01H	D15–D8	1EH	D14–D8	1FH
Saturation flag	D0	04H	D0	04H	D7	1FH
Clip stepping disable	D3	06H	D3	06H	D8	24H

NOTE: All settings shown in Table 1 are located in Page 2 of control registers.

Stereo Audio DAC

Each channel of the stereo audio DAC consists of a digital audio processing block, a digital interpolation filter, digital delta-sigma modulator, and an analog reconstruction filter. The DAC is designed to provide enhanced performance at low sample rates through increased oversampling and image filtering, thereby keeping quantization noise generated within the delta-sigma modulator and signal images strongly suppressed within the audio band to beyond 20 kHz. This is realized by keeping the upsampled rate constant at 128 x Fsref and changing the oversampling ratio as the input sample rate is changed. For Fsref of 48 kHz, the digital delta-sigma modulator always operates at a rate of 6.144 MHz. This ensures that quantization noise generated within the delta-sigma modulator stays within the frequency band below 20 kHz at all sample rates. Similarly, for Fsref rate of 44.1 kHz, the digital delta-sigma modulator always operates at a rate of 5.6448 MHz.

Digital Audio Processing

The DAC channel consists of optional filters for de-emphasis and bass, treble, midrange level adjustment, or speaker equalization. The de-emphasis function is only available for sample rates of 32 kHz, 44.1 kHz, and 48 kHz. The transfer function consists of a pole with time constant of 50ms and a zero with time constant of 15ms. Frequency response plots are given in the *Audio Codec Filter Frequency Responses* section of this data sheet.

The DAC digital effects processing block consists of a fourth order digital IIR filter with programmable coefficients (one set per channel). The filter is implemented as cascade of two biquad sections with frequency response given by:

$$\left(\frac{N_0 + 2 \times N_1 \times z^{-1} + N_2 \times z^{-2}}{32768 - 2 \times D_1 \times z^{-1} - D_2 \times z^{-2}} \right) \left(\frac{N_3 + 2 \times N_4 \times z^{-1} + N_5 \times z^{-2}}{32768 - 2 \times D_4 \times z^{-1} - D_5 \times z^{-2}} \right)$$

The N and D coefficients are fully programmable, and the entire filter can be enabled or bypassed. The coefficients for this filter implement a variety of sound effects, with bass-boost or treble boost being the most commonly used in portable audio applications. The default N and D coefficients in the part are given by:

$$\begin{aligned}
 N_0 &= N_3 = 27619 \\
 N_1 &= N_4 = -27034 \\
 N_2 &= N_5 = 26461 \\
 D_1 &= D_4 = 32131 \\
 D_2 &= D_5 = -31506
 \end{aligned}$$

These coefficients implement a shelving filter with 0 dB gain from dc to approximately 150 Hz, at which point it rolls off to 3 dB attenuation for higher frequency signals, thus giving a 3-dB boost to signals below 150 Hz. The N and D coefficients are represented by 16-bit twos complement numbers with values ranging from –32768 to +32767. Frequency response plots are given in the *Audio Codec Filter Frequency Responses* section of this data sheet.

Interpolation Filter

The interpolation filter upsamples the output of the digital audio processing block by the required oversampling ratio. It provides a linear phase output with a group delay of $21/F_s$.

In addition, the digital interpolation filter provides enhanced image filtering to reduce signal images caused by the upsampling process that are below 20 kHz. For example, upsampling an 8-kHz signal produces signal images at multiples of 8 kHz, i.e., 8 kHz, 16 kHz, 24 kHz, etc. The images at 8 kHz and 16 kHz are below 20 kHz and still audible to the listener, therefore, they must be filtered heavily to maintain a good quality output. The interpolation filter is designed to maintain at least 65 dB rejection of images that land below $7.455 F_s$. In order to utilize the programmable interpolation capability, the F_{sref} should be programmed to a higher rate (restricted to be in the range of 39 kHz to 53 kHz when the PLL is in use), and the actual F_s is set using the dividers in bits D5D3 of control register 00H/page 2. For example, if $F_s = 8$ kHz is required, then F_{sref} can be set to 48 kHz, and the DAC F_s set to $F_{sref}/6$. This ensures that all images of the 8-kHz data are sufficiently attenuated well beyond a 20-kHz audible frequency range. Passband ripple for all sample-rate cases (from 20 Hz to $0.45 F_s$) is +0.06 dB maximum.

Delta-Sigma DAC

The audio digital-to-analog converter incorporates a third order multi-bit delta-sigma modulator followed by an analog reconstruction filter. The DAC provides high-resolution, low-noise performance, using oversampling and noise shaping techniques. The analog reconstruction filter design consists of a 6 tap analog FIR filter followed by a continuous time RC filter. The analog FIR operates at 6.144 MHz (128×48 kHz, for F_{sref} of 48 kHz) or at 5.6448 MHz (128×44.1 kHz, for F_{sref} of 44.1 kHz). The DAC analog performance may be degraded by excessive clock jitter on the MCLK input. Therefore, care must be taken to keep jitter on this clock to a minimum (less than 50 ps).

DAC Digital Volume Control

The DAC has a digital volume control block, which implements programmable gain. The volume level can be varied from 0 dB to –63.5 dB in 0.5 dB steps, in addition to a mute bit, independently for each channel. The volume level of both channels can also be changed simultaneously by the master volume control. The gain is implemented with a soft-stepping algorithm, which only changes the actual volume by one step per input sample, either up or down, until the desired volume is reached. The rate of soft-stepping can be slowed to one step per two input samples through D1 of control register 04H/Page 2.

Because of soft-stepping, the host does not know when the DAC has been completely muted. This may be important if the host wishes to mute the DAC before making a significant change, such as changing sample rates. In order to help with this situation, the part provides a flag back to the host via a read-only register bit (D2–D3 of control register 04H/page 2) that alerts the host when the part has completed the soft-stepping, and the actual volume has reached the desired volume level. The soft-stepping feature can be disabled by programming D14=1 in register 1DH in Page 2. If soft-stepping is enabled, the MCLK signal should be kept applied to the device, until the DAC power-down flag is set. When this flag is set, the internal soft-stepping process and power down sequence is complete, and the MCLK can be stopped if desired.

The TSC2101 also includes functionality to detect when the user switches on or off the de-emphasis or digital audio processing functions, then (1) soft-mute the DAC volume control, (2) change the operation of the digital effects processing and (3) soft-unmute the part. This avoids any possible pop/clicks in the audio output due to instantaneous changes in the filtering. A similar algorithm is used when first powering up or down the DAC. The circuit begins operation at power-up with the volume control muted, then soft-steps it up to the desired volume level. At power-down, the logic first soft-steps the volume down to a mute level, then powers down the circuitry.

DAC Powerdown

The DAC powerdown flag (D4D3 of control register 05H/page 2) along with D10 of control register 05H/page 2 denotes the powerdown status of the DAC according to Table 2.

Table 2. DAC Powerdown Status

D10, D4, D3	POWERUP/POWERDOWN STATE OF DAC
0,0,0	DAC left and right are in stable powerup state.
0,0,1	DAC left is in stable powerup state. DAC right is in the process of powering up. The length of this state is determined by PLL and output driver powerup delays controlled by register programming.
0,1,0	DAC left is in the process of powering up. The length of this state is determined by PLL and output driver powerup delays controlled by register programming. DAC right is in stable powerup state.
0,1,1	DAC left and right are in the process of powering up. The length of this state is determined by PLL and output driver powerup delays controlled by register programming.
1,0,0	DAC left and right are in the process of powering down. The length of this state is determined by soft-stepping of volume control block.
1,0,1	DAC left is in the process of powering down. The length of this state is determined by soft-stepping of volume control block. DAC right is in stable powerdown state.
1,1,0	DAC left is in stable powerdown state. DAC right is in the process of powering down. The length of this state is determined by soft-stepping of volume control block.
1,1,1	DAC left and right are in stable powerdown state.

Analog Outputs

The TSC2101 has the capability to route the DAC output to any of the selected analog outputs. The TSC2101 provides various analog routing capabilities. All analog outputs other than the selected ones are powered down for optimal power consumption.

● Headphone Drivers

The TSC2101 features stereo headphone drivers (SPK1 and SPK2) that can deliver 44 mW per channel at 3.3-V supply, into 16-Ω loads. The TSC2101 provides flexibility to connect either of the DAC channels to either of the headphone driver outputs. It also allows mixing of signals from different DAC channels. The headphones can be connected in a single ended configuration using ac-coupling capacitors, or the capacitors can be removed and virtual ground (VGND) powered for a cap-less output connection. Note that the VGND amplifier must be powered up if the cap-less configuration is used.

In the case of an ac-coupled output, the value of the capacitors is typically chosen based on the amount of low-frequency cut that can be tolerated. The capacitor in series with the load impedance forms a high-pass filter with –3 dB cutoff frequency of $1/(2\pi RC)$ in Hz, where R is the impedance of the headphones. Use of an overly small capacitor reduces low-frequency components in the signal output and lead to low-quality audio. When driving 16-Ω headphones, capacitors of 220-μF (a commonly used value) result in a high-pass filter cutoff frequency of 45 Hz, although reducing these capacitors to 50 μF results in a cutoff frequency of 199 Hz, which is generally considered noticeable when playing music. The cutoff frequency is reduced to half of the above values if 32-Ω headphones are used instead of 16-Ω.

The TSC2101 programmable digital effects block can be used to help reduce the size of capacitors needed by implementing a low frequency boost function to help compensate for the high-pass filter introduced by the ac-coupling capacitors. For example, by using 50-μF capacitors and setting the TSC2101 programmable filter coefficients as shown below, the frequency response can be improved as shown in Figure 21.

Filter coefficients (use the same for both channels):

$$N0 = 32767, N1 = -32346, N2 = 31925, N3 = 32767, N4 = 0, N5 = 0$$

$$D0 = 32738, D1 = -32708, D4 = 0, D5 = 0$$

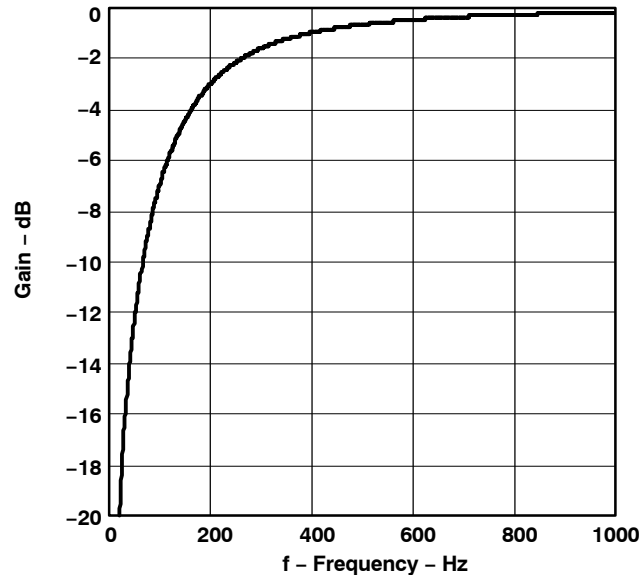

Figure 20. Uncompensated Response For 16-Ω Load and 50-μF Decoupling Capacitor

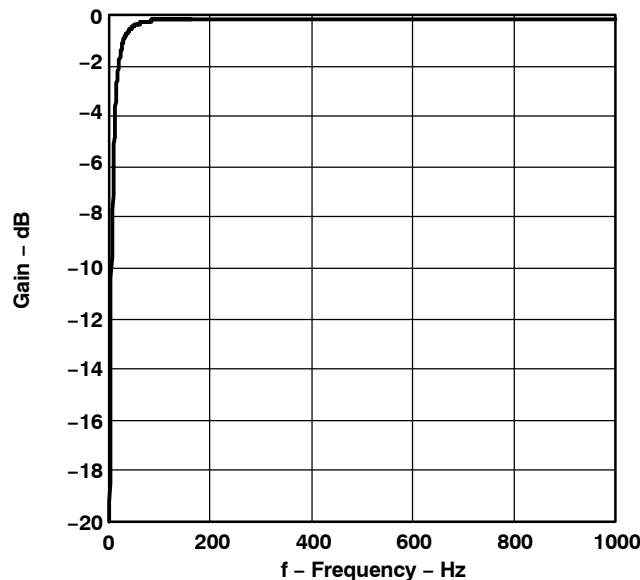

Figure 21. Frequency Response For 16-Ω Load and 50-μF Decoupling Capacitor After Gain Compensation Using Above Set of Coefficients For Audio Effects Filter

Using the capless output configuration eliminates the need for these capacitors and removes the accompanying high-pass filter entirely. However, this configuration does have one drawback – if the RETURN terminal of the headphone jack (which is wired to the TSC2101 VGND pin) is ever connected to a ground that is shorted to the TSC2101 ground pin, then the VGND amplifier enters short-circuit protection, and the audio output does not function properly.

The TSC2101 incorporates a programmable short-circuit detection/protection function. In case of short circuit, all analog outputs are disabled and a *read only* bit D1 of control register 1DH/page 2 is set. In such cases, there are two ways to return to normal operation:

- Hardware or software reset
- Power down all the output drivers, which can be achieved by setting bits D12, D11, D 8, D7, and D6 of control register 05H/page 2 and then wait for driver power down status flags (bits D15–D10 of control register 25H/page 2) to become 1. The wait time is typically less than 50 ms after which, output drivers can be programmed as desired.

For the cap interface, this feature can be disabled by setting bit D0 of control register 20H/page 2. In the case of the cap-less interface, VGND short circuit protection must also be disabled, which can be achieved by setting bit D4 of control register 21H/page 2.

The TSC2101 implements a pop reduction scheme to reduce audible artifacts during powerup and powerdown of headphone drivers. The scheme can be controlled by programming bits D5 and D4 of control register 25H/page 2. By default, the driver pop reduction scheme is enabled and can be disabled by programming bit D5 of control register 25H/page 2 to 1. When this scheme is enabled and the virtual ground connection is not used (VGND amplifier is powered down), the audio output driver slowly charges up any external ac-coupling capacitors to reduce audible artifacts. Bit D4 of control register 25H/page 2 provides control of the charging time for the ac-coupling capacitor as either 0.8 sec or 4 sec. When the virtual ground amplifier is powered up and used, the external ac-coupling capacitor is eliminated, and the powerup time becomes 1 ms. This scheme takes effect whenever any of the headphone drivers are powered up.

- **Speaker Driver**

The TSC2101 has an integrated speaker driver (OUT8P–OUT8N) capable of driving an 8 Ω differential load. The speaker driver, powered directly from the battery supply (3.5 V to 4.2 V) on the BVDD pin can deliver 400 mW at 3.9 V supply. It allows connecting one or both DAC channel to speaker driver. The TSC2101 also has a short circuit protection feature for the speaker driver which can be enabled by setting bit D5 of control register 21H/page 2.

- **Receiver Driver**

The TSC2101 includes a receiver driver (SPK1–OUT32N), which can drive a 32 Ω differential load. It is capable of delivering 82 mW into a 32 Ω load. The TSC2101 does not allow both the receiver driver and headphone drivers to be turned on at the same time. Also, when the receiver driver is being used, the headphone driver load must be disconnected.

Headset Interface

The TSC2101 supports all standard headset interfaces. It is capable of interfacing with 3-wire stereo headset, 3-wire cellular headset and 4-wire stereo-cellular headsets. It supports both capacitor-coupled (cap) and capacitor-less (capless) interface for headset through software programming.

- **Capless Interface**

Figure 22 shows the connection diagram to the TSC2101 for capless interface. VGND acts as a ground of headset jack. Voltage at VGND is 1.5 V and MICBIAS_HED voltage is programmed to 3.3 V. With this, the voltage across microphone is configured to be 1.8 V. In order to minimize the effect of routing resistance on VGND inside the device and on the printed circuit board (PCB), SPKFC should be shorted to VGND at the jack. This reduces crosstalk from speaker to microphone because of common ground as VGND.

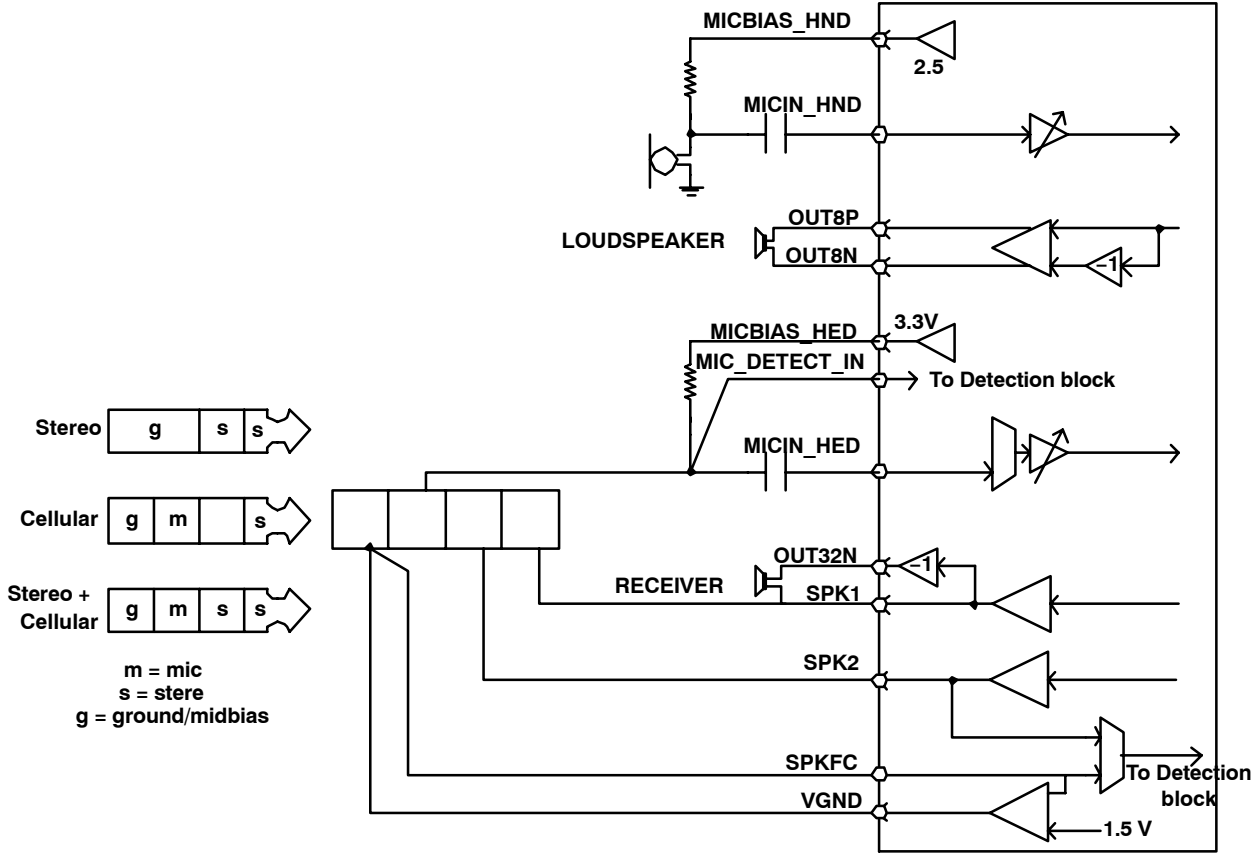

Figure 22. Connection Diagram for Capless Interface

● Cap Interface

Figure 23 shows connection diagram to device for cap interface.

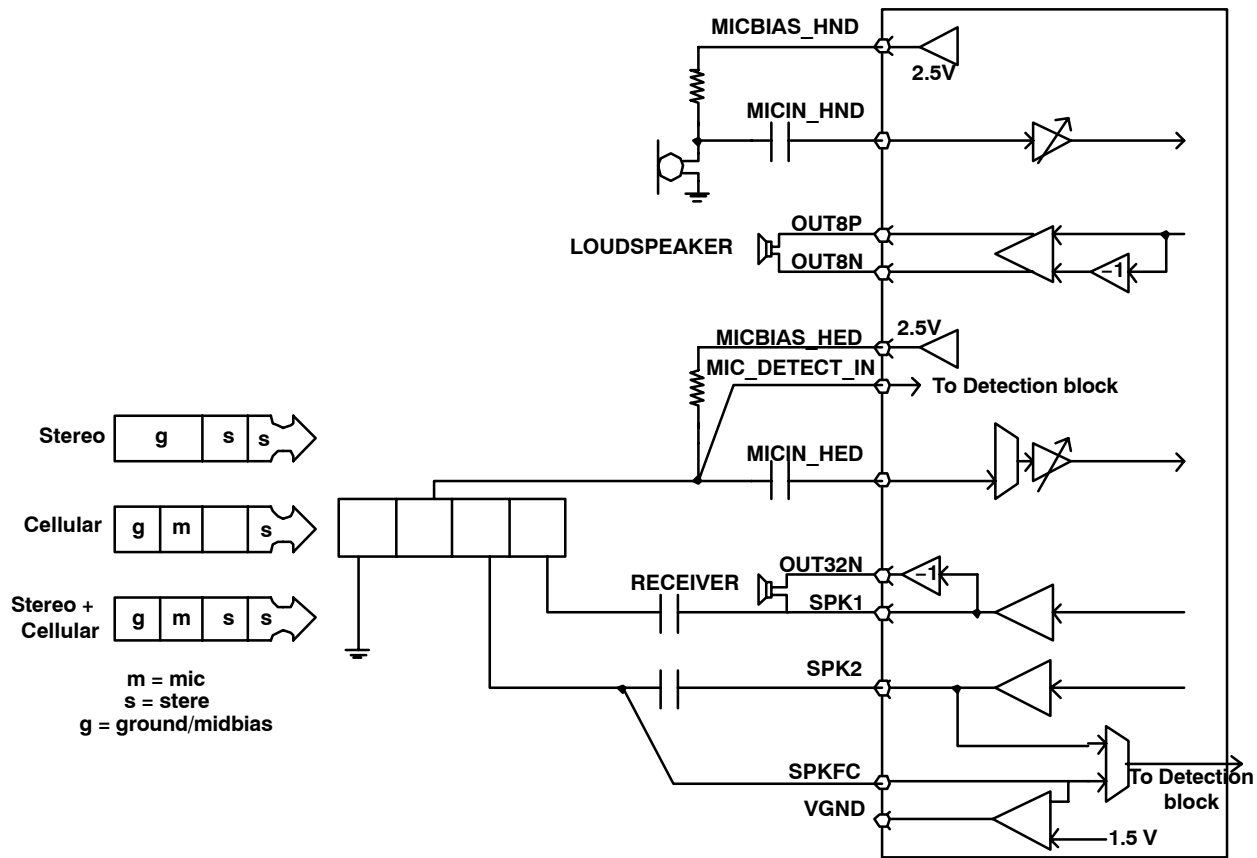

Figure 23. Connection Diagram for Cap Interface

● Auto Detection

The TSC2101 has built in monitors to automatically detect the insertion and removal of headsets. The detection scheme can differentiate between stereo, cellular and stereo-cellular headsets. Upon detection of headset insertion or removal, the TSC2101 updates read-only bit D12 of control register 22H/Page 2. The TSC2101 can be programmed to send an active high interrupt for insertion and removal of headsets to the host-processor over GPIO1 using bit D3 of control register 22H/Page 2 and GPIO2 using bit D4 of control register 22H/Page 2. The headset detection feature can be enabled by setting bit D15 of control register 22H/Page 2. When headset detection is enabled and headset is not detected, SPK1, VGND and MICBIAS_HED are turned off irrespective of control register settings. The TSC2101 also has the capability to detect button press on the headset microphone. It consumes less than 50 μ A while waiting for button press with everything else powered down. Upon button press, the TSC2101 updates read-only bit D11 of control register 22H/Page 2. It can also send an active high interrupt for indicating button press to the processor over GPIO1 using bit D1D0 of control register 22H/Page 2. The TSC2101 provides debounce programmability for headset and button detect. Debounce programmability can be used to reject glitches generated, and hence avoids false detection, while inserting headset or pressing button.

Figure 24 shows terminal connections and jack configuration required for various headsets. Care should be taken to avoid any dc path from MIC_DETECT_IN to ground, when a headset is not inserted.

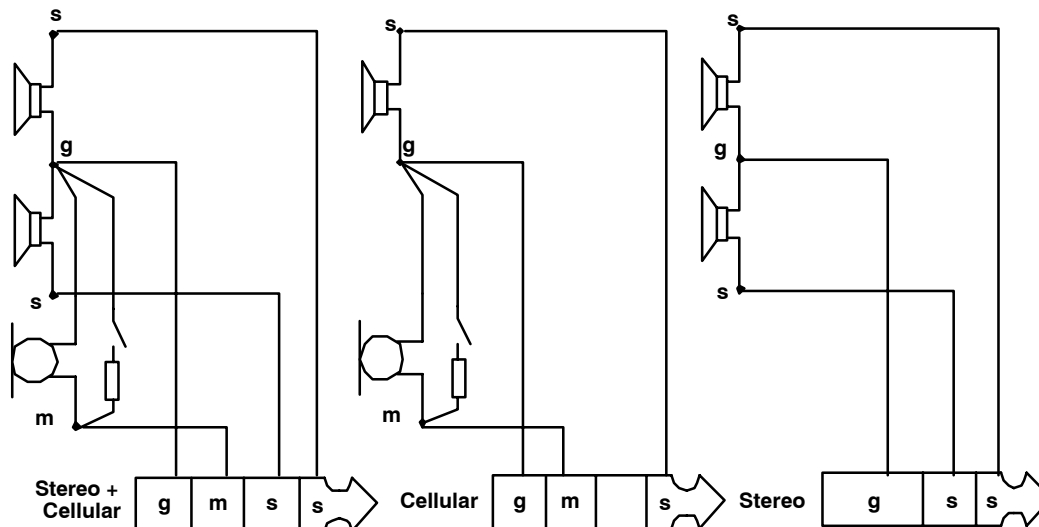

Figure 24. Connection Diagram for Jacks

- **Headset Detection**

- Interrupt polarity: Active high.
- Typical interrupt duration: 1.75 ms.
- Debounce programmability on bits D10 and D9 in control register 22H/Page 2:
 - 00 => 16 ms duration (with 2 ms clock resolution)
 - 01 => 32 ms duration (with 4 ms clock resolution)
 - 10 => 64 ms duration (with 8 ms clock resolution)
 - 11 => 128 ms duration (with 16 ms clock resolution)
- Headset detect flag is available till headset is connected.

- **Button Detection**

- Interrupt polarity: Active high.
- Typical interrupt duration: Button pressed time + clock resolution. Clock resolution depends upon debounce programmability.
- Typical interrupt delay from button: Debounce duration + 0.5ms
- Debounce programmability:
 - 00 => No glitch rejection
 - 01 => 8 ms duration (with 1 ms clock resolution)
 - 10 => 16 ms duration (with 2 ms clock resolution)
 - 11 => 32 ms duration (with 4 ms clock resolution)
- Button detect flag is set when button is pressed. It gets clear when flag read is done after button press removal.

AUDIO ROUTING

Audio Interface for Smart-Phone Applications

The TSC2101 supports audio routing features to combine various analog inputs and route them to analog outputs or the ADC for smart-phone applications. In smart-phone applications, the TSC2101 can be used to interface the cell-phone module to microphones and speakers. The TSC2101 allows the input from the cell-phone module to be routed to different speakers through a PGA which supports a range of 12 dB to –34.5 dB in steps of 0.5 dB. The cell-phone input can also be mixed with the microphone input for recording through the ADC. The microphone or DAC audio can be routed to the cell-phone output. The buzzer input from cell-phone can be routed to the speakers through a PGA. The buzzer input supports PGA range of 0 dB to –45 dB in steps of 3 dB. The mixing and PGA are under full software control. The mixing feature can be used even when both ADC and DAC are powered down. Cell-phone PGA, microphone PGA and buzzer PGA includes soft-stepping logic. Soft-stepping logic works on F_{sref} if DAC is powered up otherwise; it works on internal oscillator clocks.

Analog Mixer

The analog mixer can be used to route the analog input selected for the ADC through an analog volume control and then mix it with the audio DAC output. The analog mixer feature is available only if the single ended microphone input or the AUX input is selected as the input to the ADC, not when the ADC input is configured in fully-differential mode. This feature is available even if the ADC and DAC are powered down. The analog volume control has a range from +12 dB to –34.5 dB in 0.5 dB steps plus mute and includes soft-stepping logic. The internal oscillator is used for soft-stepping whenever the ADC and DAC are powered down.

Keyclick

A special circuit has been included for inserting a square-wave signal into the analog output signal path based on register control. This functionality is intended for generating keyclick sounds for user feedback. Register 04H/Page 2 contains bits that control the amplitude, frequency, and duration of the square-wave signal. The frequency of the signal can be varied from 62.5 Hz to 8 kHz and its duration can be programmed from 2 periods to 32 periods. Whenever this register is written, the square wave is generated and coupled into the audio output. The keyclick enable bit D15 of control register 04H/Page 2 is reset after the duration of a keyclick is played out. This capability is available even when the ADC and DAC are powered down.

OPERATION—TOUCH SCREEN

A resistive touch screen works by applying a voltage across a resistor network and measuring the change in resistance at a given point on the matrix where a screen is touched by an input stylus, pen, or finger. The change in the resistance ratio marks the location on the touch screen.

The TSC2101 supports the resistive 4-wire configurations (see Figure 25). The circuit determines location in two coordinate pair dimensions, although a third dimension can be added for measuring pressure.

The 4-Wire Touch Screen Coordinate Pair Measurement

A 4-wire touch screen is constructed as shown in Figure 25. It consists of two transparent resistive layers separated by insulating spacers.

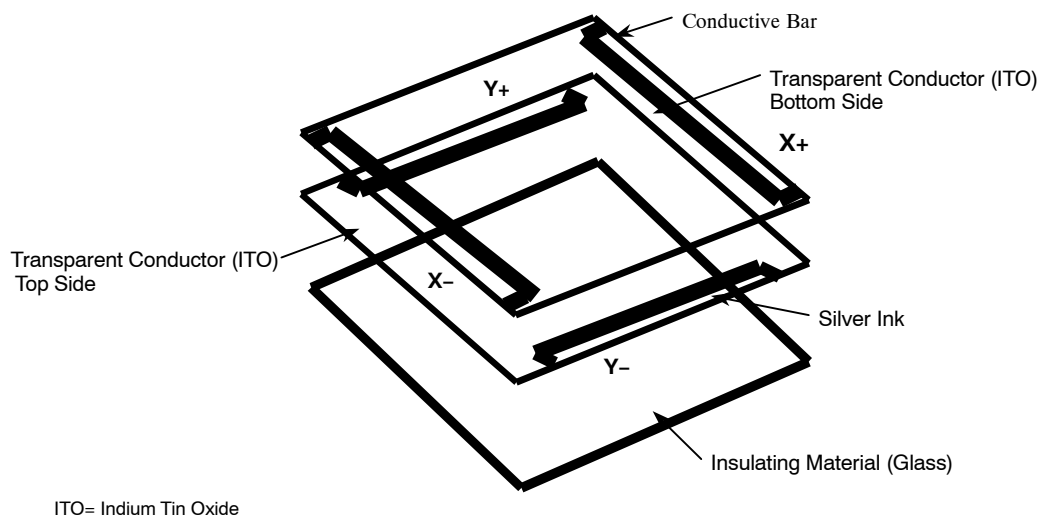

Figure 25. 4-Wire Touch Screen Construction

The 4-wire touch screen panel works by applying a voltage across the vertical or horizontal resistive network. The ADC converts the voltage measured at the point the panel is touched. A measurement of the Y position of the pointing device is made by connecting the X+ input to an ADC, turning on the Y drivers, and digitizing the voltage seen at the X+ input. The voltage measured is determined by the voltage divider developed at the point of touch. For this measurement, the horizontal panel resistance in the X+ lead does not affect the conversion due to the high input impedance of the ADC.

Voltage is then applied to the other axis, and the ADC converts the voltage representing the X position on the screen. This provides the X and Y coordinates to the associated processor.

Measuring touch pressure (Z) can also be done with the TSC2101. To determine pen or finger touch, the pressure of the *touch* needs to be determined. Generally, it is not necessary to have very high performance for this test; therefore, the 8-bit resolution mode is recommended (however, calculations are shown with the 12-bit resolution mode). There are several different ways of performing this measurement. The TSC2101 supports two methods. The first method requires knowing the X-plate resistance, measurement of the X-Position, and two additional cross panel measurements (Z_2 and Z_1) of the touch screen (see Figure 26). Using Equation (1) calculates the touch resistance:

$$R_{\text{TOUCH}} = R_{\text{X-plate}} \times \frac{\text{X-position}}{4096} \left(\frac{Z_2}{Z_1} - 1 \right) \quad (1)$$

The second method requires knowing both the X-plate and Y-plate resistance, measurement of X-Position and Y-Position, and Z_1 . Using Equation (2) also calculates the touch resistance:

$$R_{\text{TOUCH}} = \frac{R_{\text{X-plate}} \times \text{X-position}}{4096} \left(\frac{4096}{Z_1} - 1 \right) - R_{\text{Y-plate}} \times \left(1 - \frac{\text{Y-position}}{4096} \right) \quad (2)$$

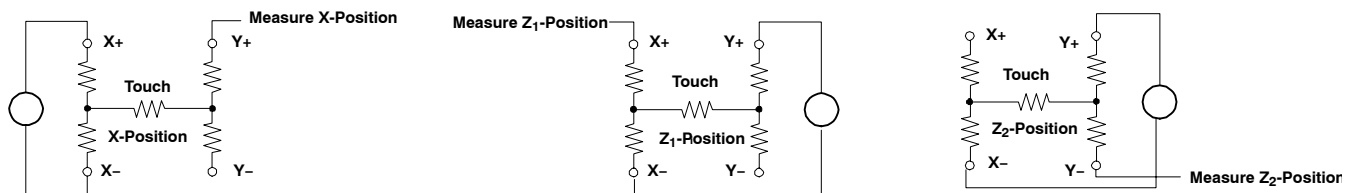

Figure 26. Pressure Measurement

When the touch panel is pressed or touched, and the drivers to the panel are turned on, the voltage across the touch panel often overshoots and then slowly settles (decays) down to a stable DC value. This is due to mechanical bouncing which is caused by vibration of the top layer sheet of the touch panel when the panel is pressed. This settling time must be accounted for, or else the converted value will be in error. Therefore, a delay must be introduced between the time the driver for a particular measurement is turned on, and the time measurement is made.

In some applications, external capacitors may be required across the touch screen for filtering noise picked up by the touch screen, i.e., noise generated by the LCD panel or back-light circuitry. The value of these capacitors provides a low-pass filter to reduce the noise, but causes an additional settling time requirement when the panel is touched.

Several solutions to this problem are available in the TSC2101. A programmable delay time is available which sets the delay between turning the drivers on and making a conversion. This is referred to as the panel voltage stabilization time, and is used in some of the modes available in the TSC2101. In other modes, the TSC2101 can be commanded to turn on the drivers only without performing a conversion. Time can then be allowed before the command is issued to perform a conversion.

The TSC2101 touch screen interface can measure position (X , Y) and pressure (Z). Determination of these coordinates is possible under three different modes of the ADC: (1) conversion controlled by the TSC2101, initiated by detection of a touch; (2) conversion controlled by the TSC2101, initiated by the host responding to the $\overline{\text{PINTDAV}}$ signal; or (3) conversion completely controlled by the host processor.

Touch Screen ADC Converter

The analog inputs of the TSC2101 are shown in Figure 27. The analog inputs (X , Y , and Z touch panel coordinates, battery voltage monitors, chip temperature and auxiliary input) are provided via a multiplexer to the successive approximation register (SAR) analog-to-digital (A/D) converter. The ADC architecture is based on capacitive redistribution architecture, which inherently includes a sample/hold function.

A unique configuration of low on-resistance switches allows an unselected ADC input channel to provide power and an accompanying pin to provide ground for driving the touch panel. By maintaining a differential input to the converter and a differential reference input architecture, it is possible to negate errors caused by the driver switch on-resistances.

The ADC is controlled by an ADC control register. Several modes of operation are possible, depending upon the bits set in the control register. Channel selection, scan operation, averaging, resolution, and conversion rate may all be programmed through this register. These modes are outlined in the sections below for each type of analog input. The results of conversions made are stored in the appropriate result register.

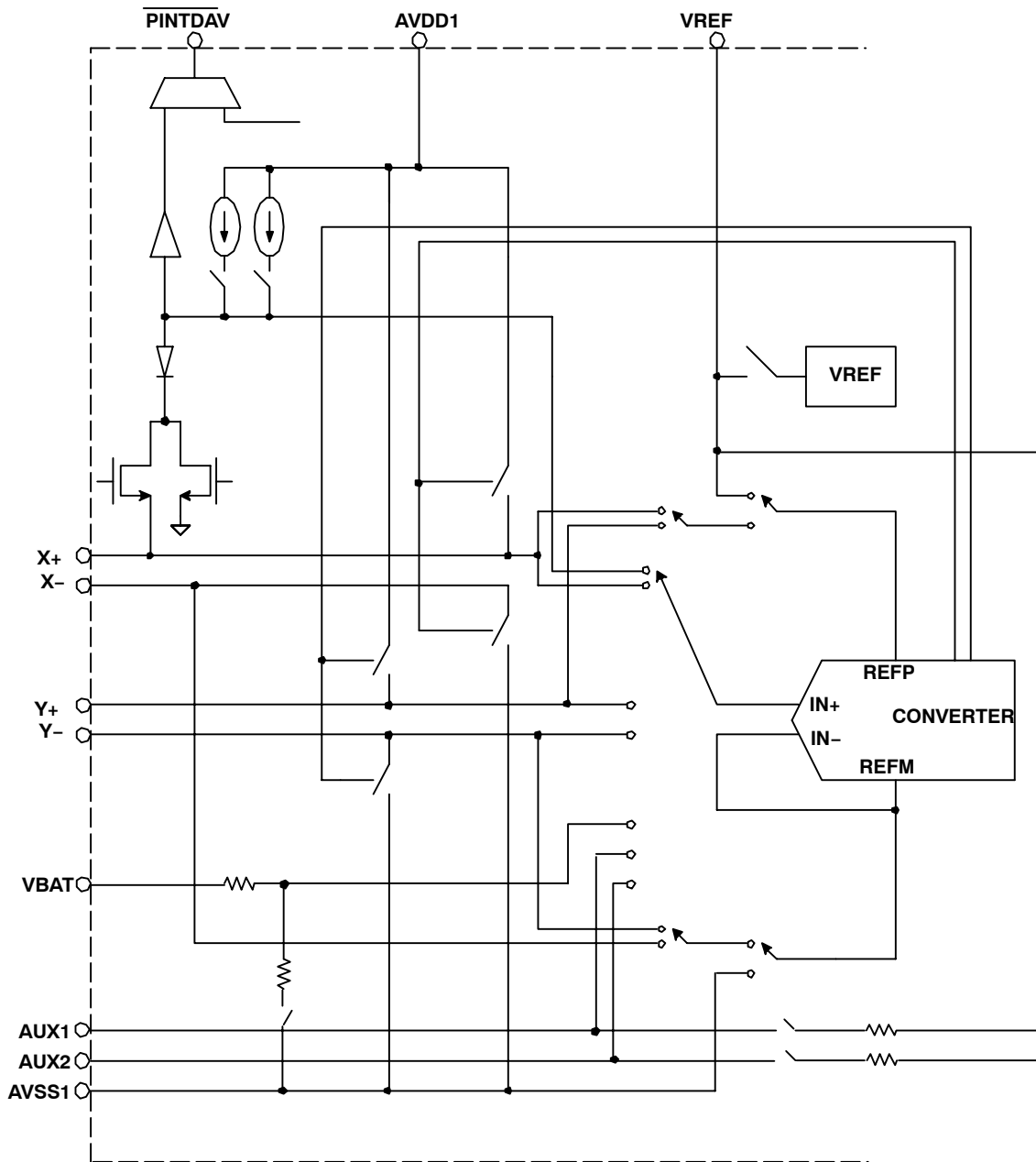

Figure 27. Simplified Diagram of the Analog Input Section

Data Format

The TSC2101 output data is in unsigned Binary format and can be read from registers over the SPI interface.

Reference

The TSC2101 has an internal voltage reference that can be set to 1.25 V or 2.5 V, through the reference control register.

The internal reference voltage should only be used in the single-ended mode for battery monitoring, temperature measurement, and for utilizing the auxiliary inputs. Optimal touch-screen performance is achieved when using a ratiometric conversion, thus all touch-screen measurements are done automatically in the ratiometric mode.

An external reference can also be applied to the VREF pin, and the internal reference can be turned off.

Variable Resolution

The TSC2101 provides three different resolutions for the ADC: 8, 10 or 12 bits. Lower resolutions are often practical for measurements such as touch pressure. Performing the conversions at lower resolution reduce the amount of time it takes for the ADC to complete its conversion process, which lowers power consumption.

Conversion Clock and Conversion Time

The TSC2101 contains an internal 8 MHz clock, which is used to drive the state machines inside the device that perform the many functions of the part. This clock is divided down to provide a clock to run the ADC. The division ratio for this clock is set in the ADC control register. The ability to change the conversion clock rate allows the user to choose the optimal value for resolution, speed, and power. If the 8 MHz clock is used directly, the ADC is limited to 8-bit resolution; using higher resolutions at this speed does not result in accurate conversions. Using a 4 MHz conversion clock is suitable for 10-bit resolution; 12-bit resolution requires that the conversion clock run at 1 or 2 MHz.

Regardless of the conversion clock speed, the internal clock runs nominally at 8 MHz. The conversion time of the TSC2101 is dependent upon several functions (see the section *Touch Screen Conversion Initiated at Touch Detect* in this data sheet). While the conversion clock speed plays an important role in the time it takes for a conversion to complete, a certain number of internal clock cycles are needed for proper sampling of the signal. Moreover, additional times, such as the panel voltage stabilization time, can add significantly to the time it takes to perform a conversion. Conversion time can vary depending upon the mode in which the TSC2101 is used. Throughout this data sheet, internal and conversion clock cycles are used to describe the times that many functions take to execute. Considering the total system design, these times must be taken into account by the user.

When both the audio ADC and DAC are powered down, the touch screen ADC uses an internal oscillator for conversions. However, to save power whenever audio ADC or DAC are powered up, the internal oscillator is powered down and MCLK and BCLK are used to clock the touch screen ADC.

The TSC2101 uses the programmed value of bit D13 in control register 06H/page 2 and the PLL programmability to derive a clock from MCLK. The various combinations are listed in Table 3.

Table 3. Conversion Clock Frequency

	D13=0 (in control register 06H/page 2)	D13=1 (in control register 06H/page 2)
PLL enabled	$\frac{MCLK \times K \times 13}{P \times 160}$	$\frac{MCLK \times K \times 17}{P \times 192}$
PLL disabled	$\frac{MCLK \times 13}{Q \times 10}$	$\frac{MCLK \times 17}{Q \times 12}$

Touch Detect/Data Available

The pen interrupt/data available ($\overline{\text{PINTDAV}}$) output function is detailed in Figure 28. While in the power-down mode, the Y– driver is ON and connected to AVSS2 and the X+ pin is connected through an on–chip pull-up resistor to AVDD2. In this mode, the X+ pin is also connected to a digital buffer and mux to drive the $\overline{\text{PINTDAV}}$ output. When the panel is touched, the X+ input is pulled to ground through the touch screen and pen-interrupt signal goes LOW due to the current path through the panel to AVSS2, initiating an interrupt to the processor. During the measurement cycles for X– and Y– position, the X+ input is disconnected from the pen-interrupt circuit to prevent any leakage current from the pull-up resistor flowing through the touch screen, and thus causing conversion errors.

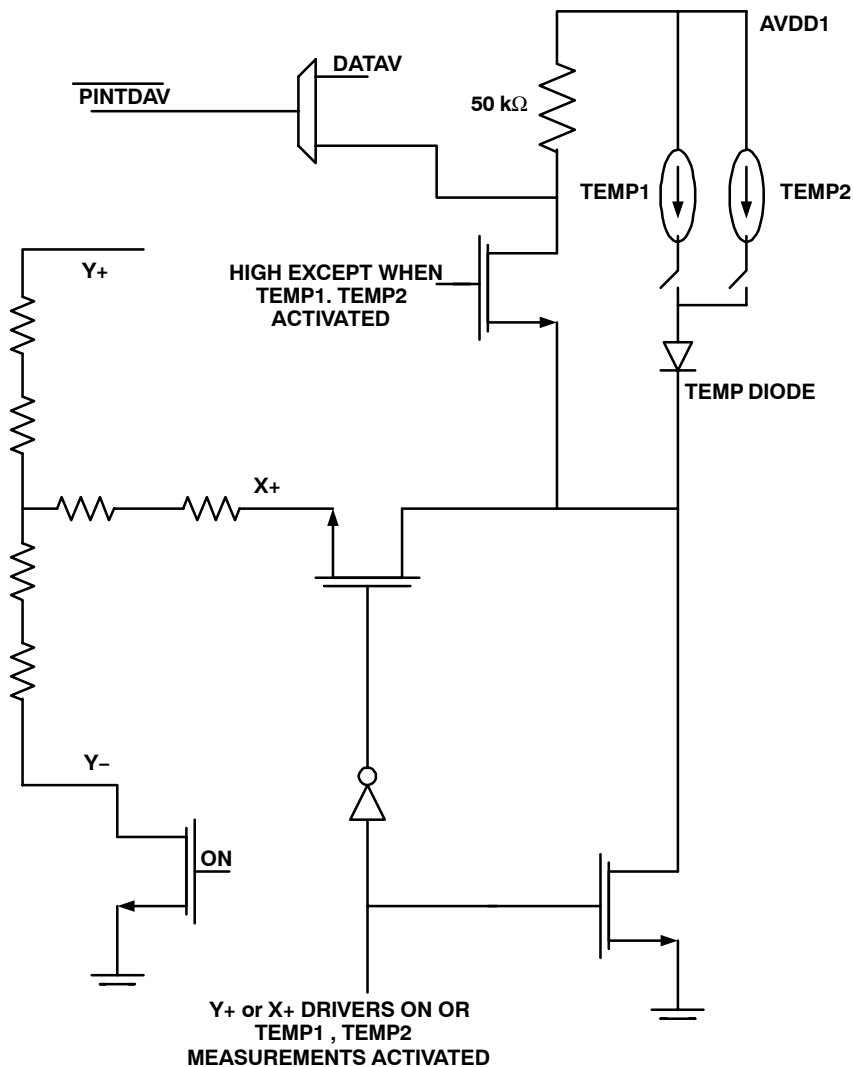

Figure 28. $\overline{\text{PINTDAV}}$ Functional Block Diagram

In modes where the TSC2101 needs to detect if the screen is still touched (for example, when doing a $\overline{\text{PINTDAV}}$ initiated X, Y, and Z conversion), the TSC2101 must reset the drivers so that the 50 K Ω resistor is connected. Because of the high value of this pull-up resistor, any capacitance on the touch screen inputs causes a long delay time, and may prevent the detection from occurring correctly. To prevent this, the TSC2101 has a circuit that allows any screen capacitance to be *precharged*, so that the pull-up resistor does not have to be the only source for the charging current. The time allowed for this precharge, as well as the time needed to sense if the screen is still touched, can be set in the configuration control register D5–D0 of register 05H/Page 1.

This does point out, however, the need to use the minimum capacitor values possible on the touch screen inputs. These capacitors may be needed to reduce noise, but too large a value will increase the needed precharge and sense times, as well as panel voltage stabilization time.

The function of $\overline{\text{PINTDAV}}$ output is programmable and controlled by writing to the bits D15–D14 of control register 01H/Page 1 as described in the Table 4.

Table 4. Programmable $\overline{\text{PINTDAV}}$ Functionality

D15–D14	$\overline{\text{PINTDAV}}$ FUNCTION
00	Acts as PEN interrupt (active low) only. When PEN touch is detected, $\overline{\text{PINTDAV}}$ goes low.
01	Acts as data available (active low) only. The $\overline{\text{PINTDAV}}$ goes low as soon as one set of ADC conversions are completed for data of X,Y, XYZ, battery input, or auxiliary input selected by D13–D10 in control register 00H/Page 1. The resulting ADC output is stored in the appropriate registers. The $\overline{\text{PINTDAV}}$ remains low and goes high only after this complete set of registers selected by D13–D10 in control register 00H/Page 1 is read out.
10 11	Acts as both PEN interrupt and data available. When PEN touch is detected, $\overline{\text{PINTDAV}}$ goes low and remains low. The $\overline{\text{PINTDAV}}$ goes high only after one set of A/D conversions is completed for data of X,Y, XYZ, battery input, or auxiliary input selected by D13–D10 in control register 00H/Page 1.

NOTE: See the section, Conversion Time Calculations for the TSC2101 in this data sheet for the timing diagrams.

Pen-touch detect circuit is disabled during hardware power down.

Touch Screen Measurements

The touch screen ADC can be either controlled by the host processor or can be self-controlled to offload processing from the host processor. Bit D12 of control register 01H/Page 1 sets the control mode of the TSC2101 touch screen ADC.

Conversion Controlled by the TSC2101 Initiated at Touch Detect

In this mode, the TSC2101 detects when the touch panel is touched and causes the $\overline{\text{PINTDAV}}$ line to go low. At the same time, the TSC2101 starts up its internal clock. Assuming the part was configured to convert XY coordinates, it then turns on the Y drivers, and after a programmed panel voltage stabilization time, powers up the ADC and converts the Y coordinate. If averaging is selected, several conversions may take place; when data averaging is complete, the Y coordinate result is stored in the Y register.

If the screen is still touched at this time, the X drivers are enabled, and the process repeats, but measuring instead the X coordinate, storing the result in the X register.

If only X and Y coordinates are to be measured, then the conversion process is complete. The time it takes to complete this process depends upon the selected resolution, internal conversion clock rate, averaging selected, panel voltage stabilization time, and precharge and sense times.

If the pressure of the touch is also to be measured, the process continues in the same way, measuring the Z1 and Z2 values, and placing them in the Z1 and Z2 registers. As before, this process time depends upon the settings described above.

See the section *Conversion Time Calculation for the TSC2101* in this data sheet for timing diagrams and conversion time calculations.

Conversion Controlled by the TSC2101 Initiated by the Host

In this mode, the TSC2101 detects when the touch panel is touched and causes the $\overline{\text{PINTDAV}}$ line to go low. The host recognizes the interrupt request, and then writes to the ADC control register (D13–D10 of control register 00H/Page 1) to select one of the touch screen scan functions. The host can either choose to initiate one of the scan functions, in which case the TSC2101 controls the driver turn-on and wait times (e.g. upon receiving the interrupt the host can initiate the continuous scan function X–Y–Z1–Z2 after which the TSC2101 controls the rest of conversion). The host can also choose to control each aspect of conversion by controlling the driver turn-on and start of conversions. For example, upon receiving the interrupt request, the host turns on the X drivers. After waiting for the settling time, the host then addresses the TSC2101 again, this time requesting an X coordinate conversion, and so on.

The main difference between this mode and the previous mode is that the host, not the TSC2101, controls the touch screen scan functions.

See the section *Conversion Time Calculation for the TSC2101* in this data sheet for timing diagrams and conversion time calculations.

Temperature Measurement

In some applications, such as battery charging, a measurement of ambient temperature is required. The temperature measurement technique used in the TSC2101 relies on the characteristics of a semiconductor junction operating at a fixed current level. The forward diode voltage (V_{BE}) has a well-defined characteristic versus temperature. The ambient temperature can be predicted in applications by knowing the 25°C value of the V_{BE} voltage and then monitoring the variation of that voltage as the temperature changes.

The TSC2101 offers two modes of temperature measurement. The first mode requires a single reading to predict the ambient temperature. A diode, as shown in Figure 29, is used during this measurement cycle. This voltage is typically 600 mV at +25°C with a 20- μ A current through it. The absolute value of this diode voltage can vary a few millivolts. The temperature coefficient of this voltage is typically 2 mV/°C. During the final test of the end product, the diode voltage at a known room temperature should be stored in nonvolatile memory. Further calibration can be done to calculate the precise temperature coefficient of the particular. This method has a temperature resolution of approximately 0.3°C/LSB and accuracy of approximately $\pm 2^\circ\text{C}$ with two-temperature calibration. Figure 30 and Figure 31 shows typical plots with single and two-temperature calibration respectively.

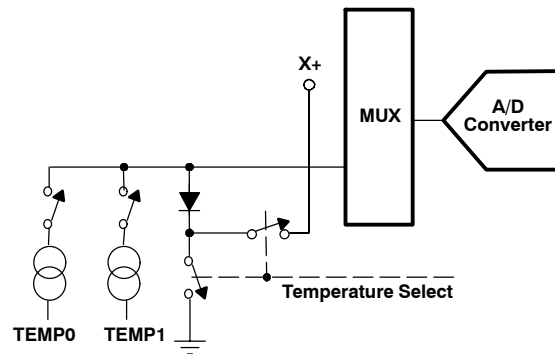

Figure 29. Functional Block Diagram of Temperature Measurement Mode

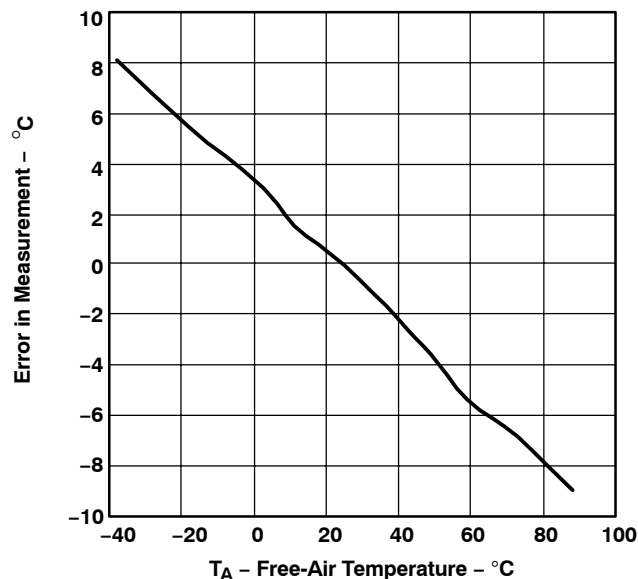

Figure 30. Typical Plot of Single Measurement Method After Calibrating for Offset at Room Temperature

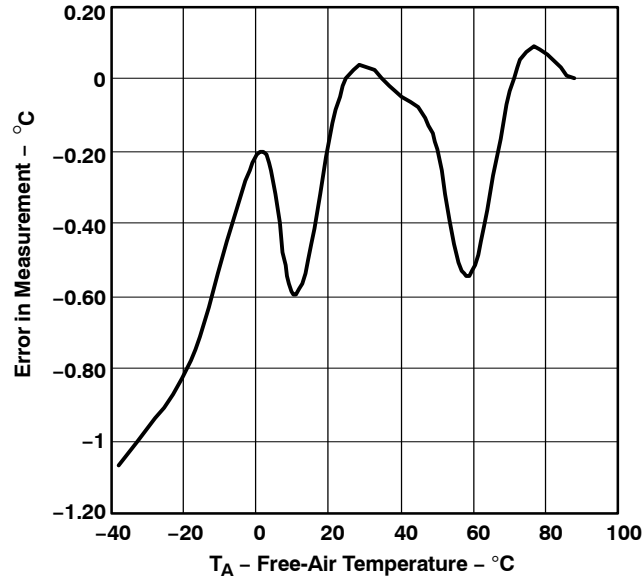

Figure 31. Typical Plot of Single Measurement Method After Calibrating for Offset and Gain At Two Temperatures

The second mode uses a two-measurement (differential) method. This mode requires a second conversion with a current 82 times larger. The voltage difference between the first (TEMP1) and second (TEMP2) conversion, using 82 times the bias current, is represented by:

$$\frac{kT}{q} \times \ln(N)$$

where:

N is the current ratio = 82

k = Boltzmann's constant ($1.38054 \cdot 10^{-23}$ electrons volts/degrees Kelvin)

q = the electron charge ($1.602189 \cdot 10^{-19}$ °C)

T = the temperature in degrees Kelvin

The equation for the relation between differential code and temperature may vary slightly from device to device and can be calibrated at final system test by the user. This method provides resolution of approximately 1.5°C/LSB and accuracy of approximately $\pm 4^\circ\text{C}$ after calibrating at room temperature.

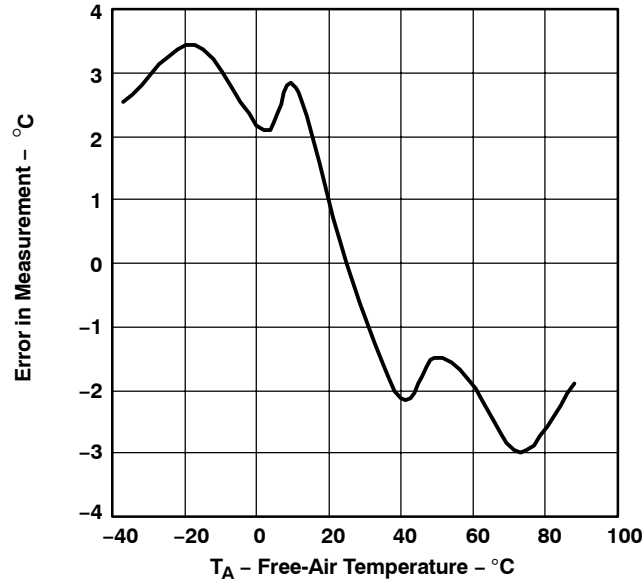

Figure 32. Typical Plot of Differential Measurement Method After Calibrating for Offset at Room Temperature

The TSC2101 supports programmable auto-temperature measurement mode, which can be enabled using control register 0CH/page 1. In this mode, the TSC2101 can auto-start the temperature measurement after a programmable interval. The user can program minimum and maximum threshold values through a register. If the measurement goes outside the threshold range, the TSC2101 sets a flag in the read only control register 0CH/page 1, which gets cleared after the flag is read. The TSC2101 can also be configured to send an active high interrupt over GPIO1 by setting D9 in control register 0CH/page 1. The duration of the interrupt is approximately 2 ms.

Temperature measurement can only be done in host controlled mode.

Battery Measurement

An added feature of the TSC2101 is the ability to monitor the battery voltage on the other side of a voltage regulator (dc/dc converter), as shown in Figure 33. The battery voltage can vary from 0.5 V to 6 V while maintaining the analog supply voltage to the TSC2101 at 3.0 V to 3.6 V. The input voltage (VBAT) is divided down by a factor of 5 so that a 6.0 V battery voltage is represented as 1.2 V to the ADC. In order to minimize the power consumption, the divider is only on during the sampling of the battery input.

If the battery conversion results in A/D output code of B , the voltage at the battery pin can be calculated as:

$$V_{\text{BAT}} = \frac{B}{2^N} \times 5 \times V_{\text{REF}}$$

Where:

N is the programmed resolution of A/D

V_{REF} is the programmed value of internal reference or the applied external reference.

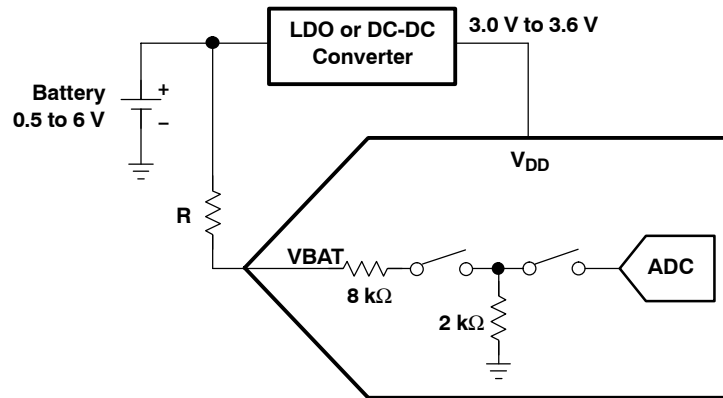

Figure 33. Battery Measurement Functional Block Diagram

Battery measurement can only be done in host–controlled mode.

See the section *Conversion Time Calculation for the TSC2101* and subsection *Non Touch Measurement Operation* in this data sheet for timing diagrams and conversion time calculations.

For increased protection and robustness, TI recommends a minimum 100–Ω resistor be added in series between the system battery and the VBAT pin. The 100–Ω resistor will cause an approximately 1% gain change in the battery voltage measurement, which can easily be corrected in software when the battery conversion data is read by the operating system.

Auxiliary Measurement

The auxiliary voltage inputs (AUX1 and AUX2) can be measured in much the same way as the battery inputs except the difference that input voltage is not divided. Applications might include external temperature sensing, ambient light monitoring for controlling the backlight, or sensing the current drawn from the battery. The auxiliary input can also be monitored continuously in scan mode.

The TSC2101 provides feature to measure resistance using auxiliary inputs. It has two modes of operation: (1) External bias resistance measurement (2) Internal bias resistance measurement. Internal bias resistance measurement mode does not need an external bias resistance of 50 kΩ, but provides less accuracy because of on chip resistance variation, which is typically ±20%. Figure 34 shows connection diagram for resistance measurement mode on AUX1.

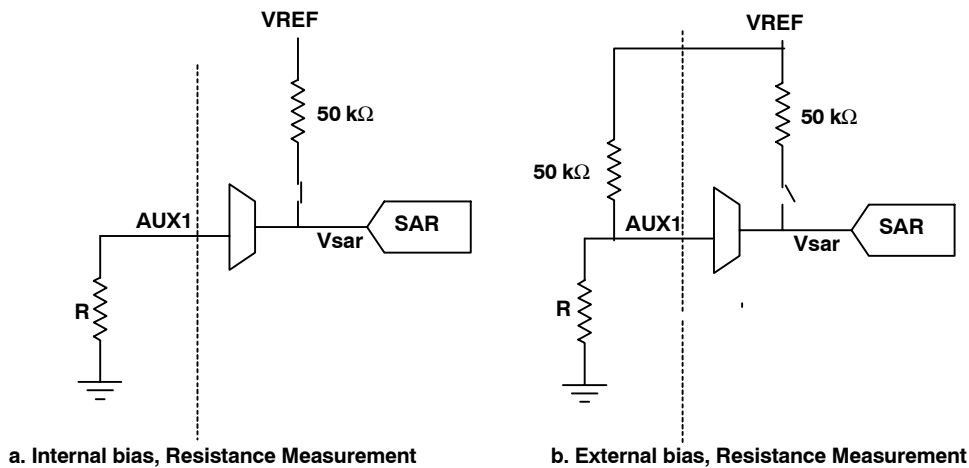

Figure 34. Connection Diagram for Resistance Measurement

Resistance can be calculated using following formula:

$$R = 50 \text{ K}\Omega \times \frac{V_{sar}}{V_{REF} - V_{sar}}$$

Where:

VREF is the SAR ADC reference

Vsar is input to the SAR ADC

The TSC2101 supports programmable auto–auxiliary measurement mode, which can be enabled using control register 0CH/page 1. In this mode, the TSC2101 can auto start the auxiliary measurement after a programmable interval. The user can program minimum and maximum threshold values through a register. If the measurement goes outside the threshold range, the TSC2101 sets a flag in the read only control register 0CH/page 1, which gets cleared after the flag is read. The TSC2101 can also be configured to send an active high interrupt over GPIO1 by setting D9 of control register 0CH/page 1. The duration of the interrupt is approximately 2 ms.

Auxiliary measurement can only be done in host–controlled mode.

See the section *Conversion Time Calculation for the TSC2101* and subsection *Non Touch Measurement Operation* in this data sheet for timing diagram and conversion time calculation

Port Scan

If making measurements of VBAT, AUX1, and AUX2 is desired on a periodic basis, the Port Scan mode can be used. This mode causes the TSC2101 to sample and convert battery input and both auxiliary inputs. At the end of this cycle, the battery and auxiliary result registers contain the updated values. Thus, with one write to the TSC2101, the host can cause three different measurements to be made.

Port Scan can only be done in host-controlled mode. See the section *Issues* at the end of this data sheet for details of a known issue with this mode.

See the section *Conversion Time Calculation for the TSC2101* and subsection *Port Scan Operation* in this data sheet for timing diagrams and conversion time calculations.

Buffer Mode

The TSC2101 supports a programmable buffer mode, which is applicable for both touch screen related conversion (X, Y, Z1, Z2) and nontouch screen related conversion (BAT, AUX1, AUX2, TEMP1, TEMP2). Buffer mode is implemented using a circular FIFO with a depth of 64. The number of interrupts required to be serviced by a host processor can be reduced significantly buffer mode. Buffer mode can be enabled using control register 02H/page1.

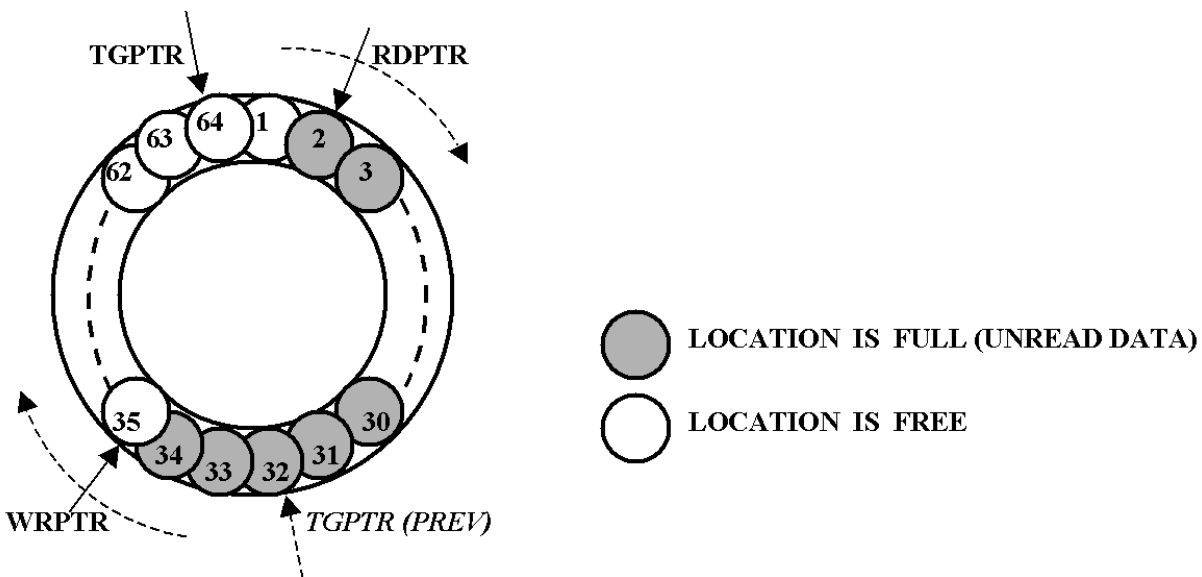

Figure 35. Circular Buffer

Converted data is automatically written into the FIFO. To control the writing, reading and interrupt process, a write pointer (WRPTR), a read pointer (RDPTR) and a trigger pointer (TGPTR) are used. The read pointer always shows the location, which will be read next. The write pointer indicates the location, in which the next converted data is going to be written. The trigger pointer indicates the location at which an interrupt will be generated if the write pointer reaches that location. Trigger level is the number of the data points needed to be present in the FIFO before generating an interrupt. For e.g., X–Y continuous scan mode with trigger level set to 8, the TSC2101 generates interrupt after writing (X1, Y1), (X2, Y2), (X3, Y3), (X4, Y4) i.e. 4 data-pairs or 8 data. Figure 35 shows the case when trigger level is programmed as 32. On resetting buffer mode, RDPTR moves to location 1, WRPTR moves to location 1, and TGPTR moves to location equal to programmed trigger level.

The user can select the input or input sequence, which needs to be converted, from the ADCSM bits of control register 00H/page 1. The converted values are written in a predefined sequence to the circular buffer. The user has flexibility to program a specific trigger level in order to choose the configuration which best fits the application. When the number of converted data, written in FIFO, becomes equal to the programmed trigger level then the device generates an interrupt signal on /PINTDAV pin. In buffer mode, the user should program this pin as Data Available ($\overline{\text{DATA_AVA}}$). In buffer mode, touch screen related conversions (X, Y, Z1, Z2) are allowed only in self-controlled mode and nontouch screen related conversions (BAT, AUX1, AUX2, TEMP1, TEMP2) are allowed only in host-controlled mode.

Buffer mode can be used in single-shot conversion or continuous conversion mode.

In single shot conversion mode, once the number of data written reaches programmed trigger level, the TSC2101 generates an interrupt and waits for the user to start reading. As soon as the user starts reading the first data from the last converted set, the TSC2101 clears the interrupt and starts a new set of conversions and the trigger pointer is incremented by the programmed trigger level. An interrupt is generated again when the trigger condition is satisfied.

In continuous conversion mode, once number of data written reaches the programmed trigger level, the TSC2101 generates an interrupt. It immediately starts a new set of conversions and the trigger pointer is incremented by the programmed trigger level. An interrupt gets cleared either by writing the next converted data into the FIFO or by starting to read from the FIFO.

See the section *Conversion Time Calculation for the TSC2101* and subsection *Buffer Mode Operation* in this data sheet for timing diagrams and conversion time calculations.

Depending upon how the user is reading data, the FIFO can become empty or full. If the user is trying to read data even if the FIFO is empty, then RDPTR keeps pointing to same location. If the FIFO gets full then the next location is overwritten with newly converted data and the read pointer is incremented by one.

While reading the FIFO, the TSC2101 provides FIFO empty and full status flags along with the data. The user can also read a status flag from control register 02H/page 1.

DIGITAL INTERFACE

RESET

The device requires reset after power up. This requires a low-to-high transition on the $\overline{\text{RESET}}$ pin after power up for correct operation. Reset initializes all the internal registers, counters and logic.

Hardware Power-Down

Hardware power-down powers down all the internal circuitry to save power. All the register contents are maintained. Putting the TSC2101 into hardware power-down circuit also disables the pen-touch detect circuit.

General Purpose I/O

The TSC2101 has two general purpose I/O (GPIO1 and GPIO2), which can be programmed either as inputs or outputs. As outputs they can be programmed to control external logic through the TSC2101 registers or send interrupts to the host processor on events like button detect, headset insertion, headset removal, Auxiliary/temperature outside threshold range etc. As inputs they can be used by the host-processor to monitor logic states of signals on the system through the TSC2101 registers.

SPI Digital Interface

All TSC2101 control registers are programmed through a standard SPI bus. The SPI allows full-duplex, synchronous, serial communication between a host processor (the master) and peripheral devices (slaves). The SPI master generates the synchronizing clock and initiates transmissions. The SPI slave devices depend on a master to start and synchronize transmissions.

A transmission begins when initiated by a master SPI. The byte from the master SPI begins shifting in on the slave MOSI pin under the control of the master serial clock. As the byte shifts in on the MOSI pin, a byte shifts out on the MISO pin to the master shift register.

The idle state of the serial clock for the TSC2101 is low, which corresponds to a clock polarity setting of 0 (typical microprocessor SPI control bit CPOL = 0). The TSC2101 interface is designed so that with a clock phase bit setting of 1 (typical microprocessor SPI control bit CPHA = 1), the master begins driving its MOSI pin and the slave begins driving its MISO pin on the first serial clock edge. The \overline{SS} pin can remain low between transmissions; however, the TSC2101 only interprets command words which are transmitted after the falling edge of \overline{SS} .

TSC2101 COMMUNICATION PROTOCOL

Register Programming

The TSC2101 is entirely controlled by registers. Reading and writing these registers is controlled by an SPI master and accomplished by the use of a 16-bit command, which is sent prior to the data for that register. The command is constructed as shown in Figure 36.

The command word begins with an R/W bit, which specifies the direction of data flow on the SPI serial bus. The following 4 bits specify the page of memory this command is directed to, as shown in Table 5. The next six bits specify the register address on that page of memory to which the data is directed. The last five bits are reserved for future use and should be written only with zeros.

Table 5. Page Addressing

PG3	PG2	PG1	PG0	PAGE ADDRESSED
0	0	0	0	0
0	0	0	1	1
0	0	1	0	2
0	0	1	1	3
0	1	0	0	Reserved
0	1	0	1	Reserved
0	1	1	0	Reserved
0	1	1	1	Reserved
1	0	0	0	Reserved
1	0	0	1	Reserved
1	0	1	0	Reserved
1	0	1	1	Reserved
1	1	0	0	Reserved
1	1	0	1	Reserved
1	1	1	0	Reserved
1	1	1	1	Reserved

To read all the first page of memory, for example, the host processor must send the TSC2101 the command 0x8000 – this specifies a read operation beginning at page 0, address 0. The processor can then start clocking data out of the TSC2101. The TSC2101 automatically increments its address pointer to the end of the page; if the host processor continues clocking data out past the end of a page, the TSC2101 sends back the value 0xFFFF.

Likewise, writing to page 1 of memory would consist of the processor writing the command 0x0800, which specifies a write operation, with PG0 set to 1, and all the ADDR bits set to 0. This results in the address pointer pointing at the first location in memory on page 1. See the section on the TSC2101 memory map for details of register locations.

BIT 15 MSB	BIT 14	BIT 13	BIT 12	BIT 11	BIT 10	BIT 9	BIT 8	BIT 7	BIT 6	BIT 5	BIT 4	BIT 3	BIT 2	BIT 1	BIT 0 LSB
R/W*	PG3	PG2	PG1	PG0	ADDR5	ADDR4	ADDR3	ADDR2	ADDR1	ADDR0	0	0	0	0	0

Figure 36. TSC2101 Command Word

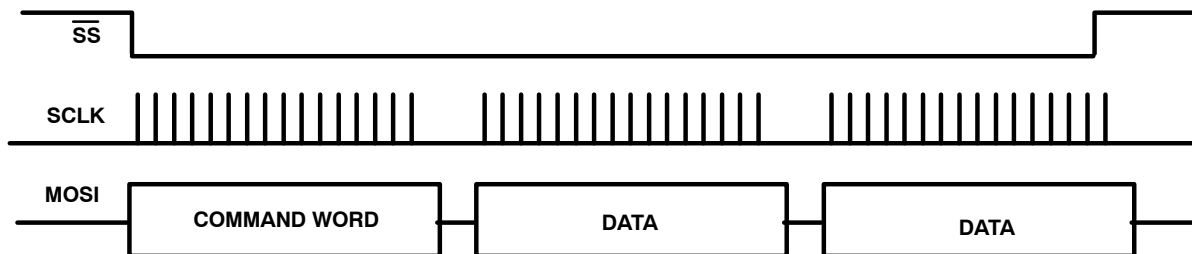

Figure 37. Register Write Operation

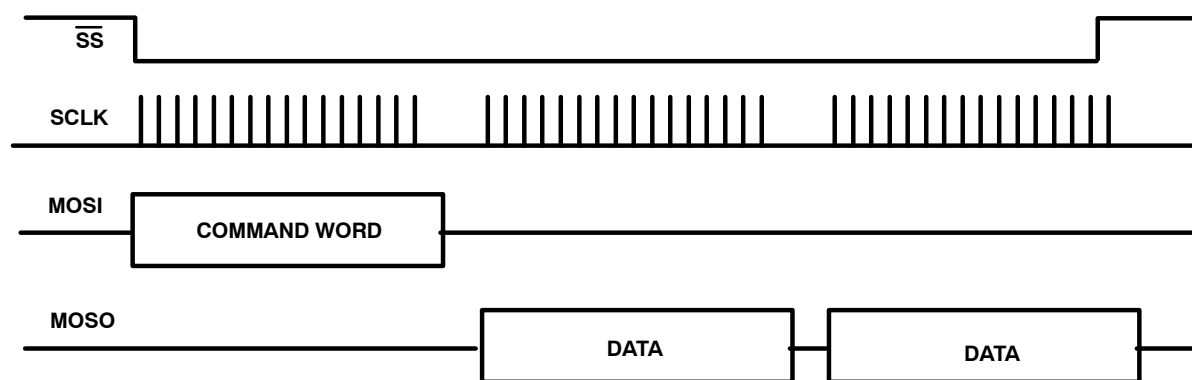

Figure 38. Register Read Operation

TSC2101 Memory Map

The TSC2101 has several 16-bit registers which allow control of the device as well as providing a location for results from the TSC2101 to be stored until read by the host microprocessor. These registers are separated into four pages of memory in the TSC2101: a data page (page 0), control pages (page 1 and page 2) and a buffer data page (page 3). The memory map is shown in Table 6.

Table 6. Memory Map

PAGE 0: TOUCH SCREEN DATA REGISTER		PAGE 1: TOUCH SCREEN CONTROL REGISTERS		PAGE 2: AUDIO CONTROL REGISTERS		PAGE 3: BUFFER DATA REGISTERS	
ADDR	REGISTER	ADDR	REGISTER	ADDR	REGISTER	ADDR	REGISTER
00	X	00	TSC ADC	00	Audio Control 1	00	Buffer Location
01	Y	01	Status	01	Headset PGA Control	01	Buffer Location
02	Z1	02	Buffer Mode	02	DAC PGA Control	02	Buffer Location
03	Z2	03	Reference	03	Mixer PGA Control	03	Buffer Location
04	Reserved	04	Reset Control Register	04	Audio Control 2	04	Buffer Location
05	BAT	05	Configuration	05	Power Down Control	05	Buffer Location
06	Reserved	06	Temperature Max	06	Audio Control 3	06	Buffer Location
07	AUX1	07	Temperature Min	07	Digital Audio Effects Filter Coefficients	07	Buffer Location
08	AUX2	08	AUX1 Max	08	Digital Audio Effects Filter Coefficients	08	Buffer Location
09	TEMP1	09	AUX1 Min	09	Digital Audio Effects Filter Coefficients	09	Buffer Location
0A	TEMP2	0A	AUX2 Max	0A	Digital Audio Effects Filter Coefficients	0A	Buffer Location
0B	Reserved	0B	AUX2 Min	0B	Digital Audio Effects Filter Coefficients	0B	Buffer Location

PAGE 0: TOUCH SCREEN DATA REGISTER		PAGE 1: TOUCH SCREEN CONTROL REGISTERS		PAGE 2: AUDIO CONTROL REGISTERS		PAGE 3: BUFFER DATA REGISTERS	
ADDR	REGISTER	ADDR	REGISTER	ADDR	REGISTER	ADDR	REGISTER
0C	Reserved	0C	Measurement Configuration	0C	Digital Audio Effects Filter Coefficients	0C	Buffer Location
0D	Reserved	0D	Programmable Delay	0D	Digital Audio Effects Filter Coefficients	0D	Buffer Location
0E	Reserved	0E	Reserved	0E	Digital Audio Effects Filter Coefficients	0E	Buffer Location
0F	Reserved	0F	Reserved	0F	Digital Audio Effects Filter Coefficients	0F	Buffer Location
10	Reserved	10	Reserved	10	Digital Audio Effects Filter Coefficients	10	Buffer Location
11	Reserved	11	Reserved	11	Digital Audio Effects Filter Coefficients	11	Buffer Location
12	Reserved	12	Reserved	12	Digital Audio Effects Filter Coefficients	12	Buffer Location
13	Reserved	13	Reserved	13	Digital Audio Effects Filter Coefficients	13	Buffer Location
14	Reserved	14	Reserved	14	Digital Audio Effects Filter Coefficients	14	Buffer Location
15	Reserved	15	Reserved	15	Digital Audio Effects Filter Coefficients	15	Buffer Location
16	Reserved	16	Reserved	16	Digital Audio Effects Filter Coefficients	16	Buffer Location
17	Reserved	17	Reserved	17	Digital Audio Effects Filter Coefficients	17	Buffer Location
18	Reserved	18	Reserved	18	Digital Audio Effects Filter Coefficients	18	Buffer Location
19	Reserved	19	Reserved	19	Digital Audio Effects Filter Coefficients	19	Buffer Location
1A	Reserved	1A	Reserved	1A	Digital Audio Effects Filter Coefficients	1A	Buffer Location
1B	Reserved	1B	Reserved	1B	PLL Programmability	1B	Buffer Location
1C	Reserved	1C	Reserved	1C	PLL Programmability	1C	Buffer Location
1D	Reserved	1D	Reserved	1D	Audio Control 4	1D	Buffer Location
1E	Reserved	1E	Reserved	1E	Handset PGA Control	1E	Buffer Location
1F	Reserved	1F	Reserved	1F	Cell & Buzzer PGA Control	1F	Buffer Location
20	Reserved	20	Reserved	20	Audio Control 5	20	Buffer Location
21	Reserved	21	Reserved	21	Audio Control 6	21	Buffer Location
22	Reserved	22	Reserved	22	Audio Control 7	22	Buffer Location
23	Reserved	23	Reserved	23	GPIO Control	23	Buffer Location
24	Reserved	24	Reserved	24	AGC–CP_IN Control	24	Buffer Location
25	Reserved	25	Reserved	25	Driver Powerdown Status	25	Buffer Location
26	Reserved	26	Reserved	26	Mic AGC control	26	Buffer Location
27	Reserved	27	Reserved	27	Cell-phone AGC Control	27	Buffer Location
28	Reserved	28	Reserved	28	Reserved	28	Buffer Location
29	Reserved	29	Reserved	29	Reserved	29	Buffer Location
2A	Reserved	2A	Reserved	2A	Reserved	2A	Buffer Location
2B	Reserved	2B	Reserved	2B	Reserved	2B	Buffer Location
2C	Reserved	2C	Reserved	2C	Reserved	2C	Buffer Location
2D	Reserved	2D	Reserved	2D	Reserved	2D	Buffer Location
2E	Reserved	2E	Reserved	2E	Reserved	2E	Buffer Location
2F–3F	Reserved	2F–3F	Reserved	2F–3F	Reserved	2F–3F	Buffer Locations

TSC2101 Control Registers

This section describes each of the registers shown in the memory map of Table 6. The registers are grouped according to the function they control. Note that in the TSC2101, bits in control registers may refer to slightly different functions depending upon if you are reading the register or writing to it.

TSC2101 Data Registers (Page 0)

The data registers of the TSC2101 hold data results from conversion of touch screen ADC. All of these registers default to 0000H upon reset. These registers are *read only*.

X, Y, Z1, Z2, BAT, AUX1, AUX2, TEMP1 and TEMP2 Registers

The results of all ADC conversions are placed in the appropriate data register. The data format of the result word, R, of these registers is right-justified, as follows:

Bit 15 MSB	Bit 14	Bit 13	Bit 12	Bit 11	Bit 10	Bit 9	Bit 8	Bit 7	Bit 6	Bit 5	Bit 4	Bit 3	Bit 2	Bit 1	Bit 0 LSB
0	0	0	0	R11 MSB	R10	R9	R8	R7	R6	R5	R4	R3	R2	R1	R0 LSB

PAGE 1 CONTROL REGISTER MAP**REGISTER 00H: Touch-Screen ADC Control**

BIT	NAME	RESET VALUE	READ/ WRITE	FUNCTION
D15	PSTCM	0	R/W	Pen Status/Control Mode. READ 0 => There is no screen touch (default). 1 => The pen is down WRITE 0 => Host controlled touch screen conversions (default). 1 => The TSC2101 controlled touch screen conversions.
D14	ADST	1 (for read) 0 (for write)	R/W	ADC STATUS. READ 0 => ADC is busy 1 => ADC is not busy (default). WRITE 0 => Normal mode (default). 1 => Stop conversion and power down.
D13–D10	ADCSM	0000	R/W	ADC Scan Mode. 0000 => No scan 0001 => Touch screen scan function: X and Y coordinates are converted and the results returned to X and Y data registers. Scan continues until either the pen is lifted or a stop bit is sent. 0010 => Touch screen scan function: X, Y, Z1 and Z2 coordinates are converted and the results returned to X, Y, Z1 and Z2 data registers. Scan continues until either the pen is lifted or a stop bit is sent. 0011 => Touch screen scan function: X coordinate is converted and the results returned to X data register. 0100 => Touch screen scan function: Y coordinate is converted and the results returned to Y data register. 0101 => Touch screen scan function: Z1 and Z2 coordinates are converted and the results returned to Z1 and Z2 data registers 0110 => BAT input is converted and the results returned to the BAT data register. 0111 => AUX2 input is converted and the results returned to the AUX2 data register 1000 => AUX1 input is converted and the results returned to the AUX1 data register. 1001 => Auto Scan function: For AUX1, AUX2, TEMP1 or TEMP2 as chosen using control register 0CH/page 1. Scan continues until stop bit is sent or D13–D10 are changed. 1010 => TEMP1 input is converted and the results returned to the TEMP1 data register. 1011 => Port scan function: BAT, AUX1, AUX2 inputs are measured and the results returned to the appropriate data registers. 1100 => TEMP2 input is converted and the results returned to the TEMP2 data register. 1101 => Turn on X+, X– drivers 1110 => Turn on Y+, Y– drivers 1111 => Turn on Y+, X– drivers
D9–D8	RESOL	00	R/W	Resolution Control. The ADC resolution is specified with these bits. 00 => 12-bit resolution 01 => 8-bit resolution 10 => 10-bit resolution 11 => 12-bit resolution

BIT	NAME	RESET VALUE	READ/ WRITE	FUNCTION										
D7–D6	ADAVG	00	R/W	Converter Averaging Control. These two bits allow user to specify the number of averages the converter will perform selected by bit D0, which selects either Mean Filter or Median Filter. <table style="margin-left: 40px; border: none;"> <tr> <td style="padding-right: 20px;">Mean Filter</td> <td>Median Filter</td> </tr> <tr> <td>00 => No average</td> <td>No average</td> </tr> <tr> <td>01 => 4-data average</td> <td>5-data average</td> </tr> <tr> <td>10 => 8-data average</td> <td>9-data average</td> </tr> <tr> <td>11 => 16-data average</td> <td>15-data average</td> </tr> </table>	Mean Filter	Median Filter	00 => No average	No average	01 => 4-data average	5-data average	10 => 8-data average	9-data average	11 => 16-data average	15-data average
Mean Filter	Median Filter													
00 => No average	No average													
01 => 4-data average	5-data average													
10 => 8-data average	9-data average													
11 => 16-data average	15-data average													
D5–D4	ADCR	00	R/W	Conversion Rate Control. These two bits specify the internal clock rate, which the ADC uses to control performing a single conversion. These bits are the same whether reading or writing. $t_{\text{conv}} = \frac{N + 4}{f_{\text{INTCLK}}}$ Where f_{INTCLK} is the internal clock frequency. For example, with 12-bit resolution and a 2 MHz internal clock frequency, the conversion time is 8 μs . This yields an effective throughput rate of 125 kHz. 00 => 8 MHz internal clock rate (use for 8-bit resolution only) 01 => 4 MHz internal clock rate (use for 8-bit/10-bit resolution only) 10 => 2 MHz internal clock rate 11 => 1 MHz internal clock rate										
D3–D1	PVSTC	000	R/W	Panel Voltage Stabilization Time Control. These bits allow user to specify a delay time from the time the touch screen drivers are enabled to the time the voltage is sampled and a conversion is started. This allows the user to adjust for the settling of the individual touch panel and external capacitances. 000 => 0 μs stabilization time 001 => 100 μs stabilization time 010 => 500 μs stabilization time 011 => 1 ms stabilization time 100 => 5 ms stabilization time 101 => 10 ms stabilization time 110 => 50 ms stabilization time 111 => 100 ms stabilization time										
D0	AVGFS	0	R/W	Average Filter Select 0 => Mean Filter 1 => Median Filter										

REGISTER 01H: Status Register

BIT	NAME	RESET VALUE	READ/ WRITE	FUNCTION
D15–D14	PINTDAV	10	R/W	Pen Interrupt or Data Available. These two bits program the function of the $\overline{\text{PINTDAV}}$ pin. 00 => Acts as PEN interrupt (active low) only. When PEN touch is detected, $\overline{\text{PINTDAV}}$ goes low. 01 => Acts as data available (active low) only. The $\overline{\text{PINTDAV}}$ goes low as soon as one set of ADC conversion(s) is completed. For scan mode, $\overline{\text{PINTDAV}}$ remains low as long as all the appropriate registers have not been read out. 10 => Acts as both PEN interrupt and data available. When PEN touch is detected, $\overline{\text{PINTDAV}}$ goes low. $\overline{\text{PINTDAV}}$ goes high once all the selected conversions are over. 11 => Same as 10
D13	PWRDN	0	R	TSC–ADC Power down status 0 => TSC–ADC is active 1 => TSC–ADC stops conversion and powers down
D12	HCTLM	0	R	Host Controlled Mode Status 0 => Host controlled mode 1 => Self (TSC2101) controlled mode
D11	DAVAIL	0	R	Data Available Status 0 => No data available. 1 => Data is available (i.e one set of conversion is done) Note:– This bit gets cleared only after all the converted data have been completely read out. This bit is not valid in case of buffer mode.

BIT	NAME	RESET VALUE	READ/ WRITE	FUNCTION
D10	XSTAT	0	R	X Data Register Status 0 => No new data is available in X–data register 1 => New data for X–coordinate is available in register Note: This bit gets cleared only after the converted data of X coordinate has been completely read out of the register. This bit is not valid in case of buffer mode.
D9	YSTAT	0	R	Y Data Register Status 0 => No new data is available in Y–data register 1 => New data for Y–coordinate is available in register Note: This bit gets cleared only after the converted data of Y coordinate has been completely read out of the register. This bit is not valid in case of buffer mode.
D8	Z1STAT	0	R	Z1 Data Register Status 0 => No new data is available in Z1–data register 1 => New data is available in Z1–data register Note: This bit gets cleared only after the converted data of Z1 coordinate has been completely read out of the register. This bit is not valid in case of buffer mode.
D7	Z2STAT	0	R	Z2 Data Register Status 0 => No new data is available in Z2–data register 1 => New data is available in Z2–data register Note: This bit gets cleared only after the converted data of Z2 coordinate has been completely read out of the register. This bit is not valid in case of buffer mode.
D6	BSTAT	0	R	BAT Data Register Status 0 => No new data is available in BAT data register 1 => New data is available in BAT data register Note: This bit gets cleared only after the converted data of BAT has been completely read out of the register. This bit is not valid in case of buffer mode.
D5		0	R	Reserved
D4	AX1STAT	0	R	AUX1 Data Register Status 0 => No new data is available in AUX1–data register 1 => New data is available in AUX1–data register Note: This bit gets cleared only after the converted data of AUX1 has been completely read out of the register. This bit is not valid in case of buffer mode.
D3	AX2STAT	0	R	AUX2 Data Register Status 0 => No new data is available in AUX2–data register 1 => New data is available in AUX2–data register Note: This bit gets cleared only after the converted data of AUX2 has been completely read out of the register. This bit is not valid in case of buffer mode.
D2	T1STAT	0	R	TEMP1 Data Register Status 0 => No new data is available in TEMP1–data register 1 => New data is available in TEMP1–data register Note: This bit gets cleared only after the converted data of TEMP1 has been completely read out of the register. This bit is not valid in case of buffer mode.
D1	T2STAT	0	R	TEMP2 Data Register Status 0 => No new data is available in TEMP2–data register 1 => New data is available in TEMP2–data register Note: This bit gets cleared only after the converted data of TEMP2 has been completely read out of the register. This bit is not valid in case of buffer mode.
D0		0	R	Reserved

REGISTER 02H: Buffer Control

BIT	NAME	RESET VALUE	READ/ WRITE	FUNCTION
D15	BUFRES	0	R/W	Buffer Reset. 0 => Buffer mode is disabled and RDPTR, WRPTR & TGPTR set to their reset value. 1 => Buffer mode is enabled.
D14	BUFCONT	0	R/W	Buffer Mode Selection 0 => Continuous conversion mode. 1 => Single shot mode.
D13–D11	BUFTL	000	R/W	Trigger Level TL selection of Buffer used for SAR ADC 000 => 8 001 => 16 010 => 24 011 => 32 100 => 40 101 => 48 110 => 56 111 => 64
D10	BUFOVF	0	R	Buffer Full Flag 0 => Buffer is not full. 1 => Buffer is full. This means buffer contains 64 unread converted data.
D9	BUFEMF	1	R	Buffer Empty Flag 0 => Buffer is not empty. 1 => Buffer is empty. This means there is no unread converted data in the buffer.
D8–D0		0's	R	Reserved

REGISTER 03H: Reference Control

BIT	NAME	RESET VALUE	READ/ WRITE	FUNCTION
D15–D6		0's	R	Reserved
D5		0	R/W	Reserved. Always write 0 to this bit.
D4	VREFM	0	R/W	Voltage Reference Mode. This bit configures the VREF pin as either external reference or internal reference. 0 => External reference 1 => Internal reference
D3–D2	RPWUDL	00	R/W	Reference Power Up Delay. These bits allow for a delay time for measurements to be made after the reference powers up, thereby assuring that the reference has settled 00 => 0 μ s 01 => 100 μ s 10 => 500 μ s 11 => 1000 μ s Note: This will be valid only when device is programmed for internal reference and Bit D1 = 1, i.e., reference is powered down between the conversions if not required.
D1	RPWDN	1	R/W	Reference Power Down. This bit controls the power down of the internal reference voltage. 0 => Powered up at all times. 1 => Powered Down between conversions. Note: When D4 = 0 i.e. device is in external reference mode then the internal reference is powered down always.
D0	IREFV	0	R/W	Internal Reference Voltage. This bit selects the internal voltage for TSC ADC. 0 => VREF = 1.25 V 1 => VREF = 2.50 V

REGISTER 04H: Reset Control

BIT	NAME	RESET VALUE	READ/ WRITE	FUNCTION
D15–D0	RSALL	R/W	FFFFH	Reset All. Writing the code 0xBB00, as shown below, to this register causes the TSC2101 to reset all its control registers to their default, power–up values. 1011101100000000 => Reset all control registers Others => Do not write other sequences to the register.

REGISTER 05H: Configuration Control

BIT	NAME	RESET VALUE	READ/ WRITE	FUNCTION
D15–D7		0's	R	Reserved
D6	SWPDTD	0	R/W	Software Powerdown Control for Pen Touch Detection 0 => Pen touch detection is enabled. 1 => Pen touch detection is disabled.
D5–D3	PRECTM	000	R/W	Precharge Time. These bits set the amount of time allowed for precharging any pin capacitance on the touch screen prior to sensing if a screen touch is happening. 000 => 20 μ s 001 => 84 μ 010 => 276 μ 011 => 340 μ s 100 => 1.044 ms 101 => 1.108 ms 110 => 1.300 m 111 => 1.364 ms
D2–D0	RPWUDL	000	R/W	Sense Time. These bits set the amount of time the TSC2101 need to wait to sense a screen touch between coordinate axes. 000 => 32 μ s 001 => 96 μ s 010 => 544 μ s 011 => 608 μ s 100 => 2.080 ms 101 => 2.144 m 110 => 2.592 ms 111 => 2.656 ms

REGISTER 06H: Temperature Max Threshold Measurement

BIT	NAME	RESET VALUE	READ/ WRITE	FUNCTION
D15–D13		0's	R	Reserved
D12	TMXES	0	R/W	Max Temperature (TEMP1 or TEMP2) threshold check enable for Auto/Non–Auto–Scan Measurement. 0 => Max Temperature threshold check is disabled. 1 => Max Temperature threshold check is enabled. Only valid for TEMP1 or TEMP2. Depends on bit TSCAN of control register 0CH/page 1 in case of auto–scan measurement and depends on bits ADCSM of control register 00H/page 1 in case of non–auto–scan measurement.
D11–D0	TTHRESH	FFFH	R/W	Temperature Max Threshold. When code due to temperature measurement goes above or equal to programmed threshold value, interrupt is generated.

REGISTER 07H: Temperature Min Threshold Measurement

BIT	NAME	RESET VALUE	READ/ WRITE	FUNCTION
D15–D13		0's	R	Reserved
D12	TMNES	0	R/W	Min Temperature (TEMP1 or TEMP2) threshold check enable for Auto/Non–Auto–Scan Measurement. 0 => Min Temperature threshold check is disabled. 1 => Min Temperature threshold check is enabled. Only valid for TEMP1 or TEMP2. Depends on bit TSCAN of control register 0CH/page 1 in case of auto–scan measurement and depends on bits ADCSM of control register 00H/page 1 in case of non–auto–scan measurement.
D11–D0	TTHRESL	000H	R/W	Temperature Min Threshold. When code due to temperature measurement goes below or equal to programmed threshold value, interrupt is generated.

REGISTER 08H: AUX1 Max Threshold Measurement

BIT	NAME	RESET VALUE	READ/ WRITE	FUNCTION
D15–D13		0's	R	Reserved
D12	A1MXES	0	R/W	Max AUX1 threshold check enable for Auto/Non–Auto–Scan Measurement. 0 => Max AUX1 threshold check is disabled. 1 => Max AUX1 threshold check is enabled.
D11–D0	A1THRESH	FFFH	R/W	AUX1 Threshold. When code due to AUX1 measurement goes above or equal to programmed threshold value, interrupt is generated.

REGISTER 09H: AUX1 Min Threshold Measurement

BIT	NAME	RESET VALUE	READ/ WRITE	FUNCTION
D15–D13		0's	R	Reserved
D12	A1MNES	0	R/W	Min AUX1 threshold check enable for Auto/Non–Auto–Scan Measurement. 0 => Min AUX1 threshold check is disabled. 1 => Min AUX1 threshold check is enabled.
D11–D0	A1THRESL	000H	R/W	AUX1 Threshold. When code due to AUX1 measurement goes below or equal to programmed threshold value, interrupt is generated.

REGISTER 0AH: AUX2 Max Threshold Measurement

BIT	NAME	RESET VALUE	READ/ WRITE	FUNCTION
D15–D13		0's	R	Reserved
D12	A2MXES	0	R/W	Max AUX2 threshold check enable for Auto/Non–Auto–Scan Measurement. 0 => Max AUX2 threshold check is disabled. 1 => Max AUX2 threshold check is enabled.
D11–D0	A1THRESH	FFFH	R/W	AUX2 Threshold. When code due to AUX2 measurement goes above or equal to programmed threshold value, interrupt is generated.

REGISTER 0BH: AUX2 Max Threshold Measurement

BIT	NAME	RESET VALUE	READ/ WRITE	FUNCTION
D15–D13		0's	R	Reserved
D12	A2MNES	0	R/W	Min AUX2 threshold check enable for Auto/Non–Auto–Scan Measurement. 0 => Min AUX2 threshold check is disabled. 1 => Min AUX2 threshold check is enabled.
D11–D0	A2THRESL	000H	R/W	AUX2 Threshold. When code due to AUX2 measurement goes below or equal to programmed threshold value, interrupt is generated.

REGISTER 0CH: Measurement Configuration

BIT	NAME	RESET VALUE	READ/ WRITE	FUNCTION
D15	TSCAN	0	R/W	TEMP Configuration when Auto–Temperature is selected 0 => TEMP1 is used for auto–temperature function 1 => TEMP2 is used for auto–temperature function
D15	A1CONF	0	R/W	AUX1 Configuration. 0 => AUX1 is used for voltage measurement. 1 => AUX1 is used for resistance measurement.
D14	A2CONF	0	R/W	AUX2 Configuration. 0 => AUX2 is used for voltage measurement. 1 => AUX2 is used for resistance measurement.
D12	ATEMES	0	R/W	Auto Temperature (TEMP1 or TEMP2) measurement enable 0 => Auto temperature measurement is disabled. 1 => Auto temperature measurement is enabled. TEMP1 or TEMP2 selection is depends on TSCAN bit.
D11	AA1MES	0	R/W	Auto AUX1 measurement enable 0 => Auto AUX1 measurement is disabled. 1 => Auto AUX1 measurement is enabled.
D10	AA2MES	0	R/W	Auto AUX2 measurement enable 0 => Auto AUX2 measurement is disabled. 1 => Auto AUX2 measurement is enabled.
D9	IGPIO1	0	R/W	Enable GPIO1 for Auto/Non–Auto–Scan interrupt (this programmability is valid only if D11 & D9 of control register 23H/page 2 are 0's) 0 => GPIO1 is not selected for interrupt. 1 => GPIO1 is used to send an interrupt. Interrupt is generated when any of TEMP (TEMP1 or TEMP2), AUX1 or AUX2 are not passing threshold
D8	THMXFL	0	R	Max threshold flag for Temperature (TEMP1 or TEMP2) measurement. 0 => Temperature measurement is less than max threshold setting. 1 => Temperature measurement is greater than or equal to max threshold setting.
D7	THMNFL	0	R	Min threshold flag for Temperature (TEMP1 or TEMP2) measurement. 0 => Temperature measurement is greater than min threshold setting. 1 => Temperature measurement is less than or equal to max threshold setting.
D6	A1HMXFL	0	R	Max threshold flag for AUX1 measurement. 0 => AUX1 measurement is less than max threshold setting. 1 => AUX1 measurement is greater than or equal to max threshold setting.
D5	A1HMNFL	0	R	Min threshold flag for AUX1 measurement. 0 => AUX1 measurement is greater than min threshold setting. 1 => AUX1 measurement is less than or equal to max threshold setting.
D4	A2HMXFL	0	R	Max threshold flag for AUX2 measurement. 0 => AUX2 measurement is less than max threshold setting. 1 => AUX2 measurement is greater than or equal to max threshold setting.
D3	A2HMNFL	0	R	Min threshold flag for AUX2 measurement. 0 => AUX2 measurement is greater than min threshold setting. 1 => AUX2 measurement is less than or equal to max threshold setting.
D2	EXTRES	0	R/W	External Bias Resistance Measurement mode 0 => Internal bias resistance measurement mode is enabled. 1 => External bias resistance measurement mode is enabled.
D1–D0		0's	R	Reserved

REGISTER 0DH: Programmable Delay In-Between Continuous Conversion

BIT	NAME	RESET VALUE	READ/ WRITE	FUNCTION
D15	NTSPDELE N	0	R/W	Programmable delay for non–touch screen auto measurement mode 0 => Programmable delay is disabled for non–touch screen auto measurement mode. 1 => Programmable delay is enabled for non–touch screen auto measurement mode.
D14–D12	NTSPDINTV	010	R/W	Programming delay in–between conversion for non–touch screen auto measurement mode 000 => 1.12 min 001 => 3.36 min 010 => 5.59 min 011 => 7.83 min 100 => 10.01 min 101 => 12.30 min 110 => 14.54 min 111 => 16.78 min Note: These delays are from end of one set of conversion to the start of another set of conversion.
D11	TSPDELEN	0	R/W	Programmable delay for touch screen measurement 0 => Programmable delay mode is disabled for touch screen measurement. 1 => Programmable delay mode is enabled for touch screen measurement. Note: This mode is valid only for touch screen related conversion in self–controlled mode and in host–controlled mode valid for only continuous scan for X & Y coordinates or for X, Y, Z1 & Z2 coordinates.
D10–D8	TSPDINTV	010	R/W	Programming delay in–between conversion for touch screen measurement 000 => 1 ms 001 => 3 ms 010 => 5 ms 011 => 6.5 ms 100 => 8.5 ms 101 => 10 ms 110 => 12.5 ms 111 => 15 ms Note: These delays are from end of one set of conversion to the start of another set of conversion.
D7	CLKSEL	0	R/W	Clock selection for the touch screen controller 0 => Internal oscillator clock is selected. 1 => External MCLK is selected. Note: External clock is used only to control the delay programmed in between the conversion.
D6–D0	CLKDIV	0000001	R/W	Clock Division used to divide MCLK for getting 1 MHz clock for programmable delay, i.e. MCLK/CLKDIV = 1 MHz, 0000000 => 128, 0000001 => 1, 0000010 => 2, 1111110 => 126, 1111111 => 127

REGISTER 0EH: Reserved

BIT	NAME	RESET VALUE	READ/ WRITE	FUNCTION
D15–D8	RESV	FFh	R/W	Reserved. Write only FFh to these bits.

PAGE 2 CONTROL REGISTER MAP**REGISTER 00H: Audio Control 1**

BIT	NAME	RESET VALUE	READ/ WRITE	FUNCTION
D15–D14	ADCHPF	00	R/W	ADC High Pass Filter 00 => Disabled 01 => –3db point = 0.0045x F_s 10 => –3dB point = 0.0125x F_s 11 => –3dB point = 0.025x F_s Note: F_s is ADC sample rate
D13–D12		0's	R	Reserved
D11–D10	WLEN	00	R/W	Codec Word Length 00 => Word length = 16–bit 01 => Word length = 20–bit 10 => Word length = 24–bit 11 => Word length = 32–bit
D9–D8	DATFM	00	R/W	Digital Data Format 00 => I2S Mode 01 => DSP Mode 10 => Right Justified 11 => Left Justified Note: Right justified valid only when the ratio between DAC and ADC sample rate is an integer. e.g. ADC = 32 kHz and DAC = 24 kHz or vice-versa is invalid for right justified Mode.
D7–D6		0's	R	Reserved
D5–D3	DACFS	000	R/W	DAC Sampling Rate 000 => DAC FS = $F_{sref}/1$ 001 => DAC FS = $F_{sref}/(1.5)$ 010 => DAC FS = $F_{sref}/2$ 011 => DAC FS = $F_{sref}/3$ 100 => DAC FS = $F_{sref}/4$ 101 => DAC FS = $F_{sref}/5$ 110 => DAC FS = $F_{sref}/(5.5)$ 111 => DAC FS = $F_{sref}/6$ Note: F_{sref} is set between 39 kHz and 53 kHz
D2–D0	ADCFS	000	R/W	ADC Sampling Rate 000 => ADC FS = $F_{sref}/1$ 001 => ADC FS = $F_{sref}/(1.5)$ 010 => ADC FS = $F_{sref}/2$ 011 => ADC FS = $F_{sref}/3$ 100 => ADC FS = $F_{sref}/4$ 101 => ADC FS = $F_{sref}/5$ 110 => ADC FS = $F_{sref}/(5.5)$ 111 => ADC FS = $F_{sref}/6$ Note: F_{sref} is set between 39 kHz and 53 kHz

REGISTER 01H: Gain Control for Headset/Aux Input

BIT	NAME	RESET VALUE	READ/ WRITE	FUNCTION																																																			
D15	ADMUT_HED	1	R/W	Headset/Aux Input Mute 1 => Headset/Aux Input Mute 0 => Headset/Aux Input not muted Note: If AGC is enabled and Headset/Aux Input is selected then ADMUT_HED+ADPGA_HED reflects gain being applied by AGC.																																																			
D14–D8	ADPGA_HED	1111111	R/W	ADC Headset/Aux PGA Settings 0000000 => 0 dB 0000001 => 0.5 dB 0000010 => 1.0 dB 1110110 => 59.0 dB 1111111 => 59.5 dB Note: If AGC is enabled and Headset/Aux Input is selected then ADMUT_HED+ADPGA_HED reflects gain being applied by AGC. If AGC is on, the decoding for read values is as follows 01110111 => +59.5 dB 01110110 => +59.0 dB 00000000 => 0 dB 11101001 => -11.5 dB 11101000 => -12 dB																																																			
D7–D5	AGCTG_HED	000	R/W	AGC Target Gain for Headset/Aux Input. These three bits set the AGC's targeted ADC output level. 000 => -5.5 dB 001 => -8.0 dB 010 => -10 dB 011 => -12 dB 100 => -14 dB 101 => -17 dB 110 => -20 dB 111 => -24 dB																																																			
D4–D1	AGCTC_HED	0000	R/W	AGC Time Constant for Headset/Aux Input. These four bits set the AGC attack and decay time constants. Time constants remain same irrespective of any sampling frequency <table border="0"> <thead> <tr> <th></th> <th>Attack time (ms)</th> <th>Decay time (ms)</th> </tr> </thead> <tbody> <tr><td>0000</td><td>8</td><td>100</td></tr> <tr><td>0001</td><td>11</td><td>100</td></tr> <tr><td>0010</td><td>16</td><td>100</td></tr> <tr><td>0011</td><td>20</td><td>100</td></tr> <tr><td>0100</td><td>8</td><td>200</td></tr> <tr><td>0101</td><td>11</td><td>200</td></tr> <tr><td>0110</td><td>16</td><td>200</td></tr> <tr><td>0111</td><td>20</td><td>200</td></tr> <tr><td>1000</td><td>8</td><td>400</td></tr> <tr><td>1001</td><td>11</td><td>400</td></tr> <tr><td>1010</td><td>16</td><td>400</td></tr> <tr><td>1011</td><td>20</td><td>400</td></tr> <tr><td>1100</td><td>8</td><td>500</td></tr> <tr><td>1101</td><td>11</td><td>500</td></tr> <tr><td>1110</td><td>16</td><td>500</td></tr> <tr><td>1111</td><td>20</td><td>500</td></tr> </tbody> </table>		Attack time (ms)	Decay time (ms)	0000	8	100	0001	11	100	0010	16	100	0011	20	100	0100	8	200	0101	11	200	0110	16	200	0111	20	200	1000	8	400	1001	11	400	1010	16	400	1011	20	400	1100	8	500	1101	11	500	1110	16	500	1111	20	500
	Attack time (ms)	Decay time (ms)																																																					
0000	8	100																																																					
0001	11	100																																																					
0010	16	100																																																					
0011	20	100																																																					
0100	8	200																																																					
0101	11	200																																																					
0110	16	200																																																					
0111	20	200																																																					
1000	8	400																																																					
1001	11	400																																																					
1010	16	400																																																					
1011	20	400																																																					
1100	8	500																																																					
1101	11	500																																																					
1110	16	500																																																					
1111	20	500																																																					
D0	AGCEN_HED	0	R/W	AGC Enable for Headset/Aux Input 0 => AGC is off for Headset/Aux Input (ADC Headset/Aux PGA is controlled by ADMUT_HED+ADPGA_HED) 1 => AGC is on for Headset/Aux Input (ADC Headset/Aux PGA is controlled by AGC)																																																			

REGISTER 02H: CODEC DAC Gain Control

BIT	NAME	RESET VALUE	READ/ WRITE	FUNCTION
D15	DALMU	1	R/W	DAC Left Channel Mute 1 => DAC Left Channel Muted 0 => DAC Left Channel not muted
D14–D8	DALVL	1111111	R/W	DAC Left Channel Volume Control 0000000 => DAC left channel volume = 0 dB 0000001 => DAC left channel volume = –0.5 dB 1111110 => DAC left channel volume = –63.0 dB 1111111 => DAC left channel volume = –63.5 dB
D7	DARMU	1	R/W	DAC Right Channel Mute 1 => DAC Right Channel Muted 0 => DAC Right Channel not muted
D6–D0	DARVL	1111111	R/W	DAC Right Channel Volume Control 0000000 => DAC right channel volume = 0 dB 0000001 => DAC right channel volume = –0.5 dB 1111110 => DAC right channel volume = –63.0 dB 1111111 => DAC right channel volume = –63.5 dB

REGISTER 03H: Mixer PGA Control

BIT	NAME	RESET VALUE	READ/ WRITE	FUNCTION
D15	ASTMU	1	R/W	Analog Sidetone Mute Control 1 => Analog sidetone mute 0 => Analog sidetone not muted
D14–D8	ASTG	1000101	R/W	Analog Sidetone Gain Setting 0000000 => Analog sidetone = –34.5 dB 0000001 => Analog sidetone = –34 dB 0000010 => Analog sidetone = –33.5 dB ... 1000101 => Analog sidetone = 0 dB 1000110 => Analog sidetone = 0.5 dB ... 1011100 => Analog sidetone = 11.5 dB 1011101 => Analog sidetone = 12 dB 1011110 => Analog sidetone = 12 dB 1011111 => Analog sidetone = 12 dB 11xxxxx => Analog sidetone = 12 dB
D7–D5	MICSEL	000	R/W	Selection for Mic Input and Aux Input for ADC/Cell phone–output/Analog side–tone. 000 => Single-ended input MICIN_HED selected 001 => Single-ended input MICIN_HND selected 010 => Single-ended input AUX1 selected 011 => Single-ended input AUX2 selected 100 => Differential input MICIN_HED and AUX1 connected to ADC. 101 => Differential input MICIN_HED and AUX2 connected to ADC. 110 => Differential input MICIN_HND and AUX1 connected to ADC. 111 => Differential input MICIN_HND and AUX2 connected to ADC. Note: When D7=1 (differential input selected), analog side–tone path is not valid
D4	MICADC	0	R/W	Selection of ADC input 0 => Nothing connected 1 => Input selected by MICSEL connected to ADC.
D3	CPADC	0	R/W	Connects Cell phone input to ADC 0 => Cell phone input not connected to ADC. 1 => Cell phone input connected to ADC.
D2–D1	Reserved	0's	R	Reserved
D0	ASTGF	0	R	Analog Sidetone PGA Flag (Read Only) 0 => Gain Applied ≠ PGA Register setting 1 => Gain Applied = PGA register setting. Note: This flag indicates when the soft–stepping for analog sidetone is completed.

REGISTER 04H: Audio Control 2

BIT	NAME	RESET VALUE	READ/ WRITE	FUNCTION
D15	KCLEN	0	R/W	Keyclick Enable 0 => Keyclick Disabled 1 => Keyclick Enabled Note: This bit is automatically cleared after giving out the keyclick signal length equal to the programmed value.
D14–D12	KCLAC	100	R/W	Keyclick Amplitude Control 000 => Lowest Amplitude 100 => Medium Amplitude 111 => Highest Amplitude
D11	APGASS	0	R/W	Headset/Aux or Handset PGA Soft–stepping control 0 => 0.5 dB change every WCLK or ADWS 1 => 0.5 dB change every 2 WCLK or 2 ADWS When AGC is enabled for Headset/Aux or Handset, this bit is read only and acts as Noise Threshold Flag. The read value indicates the following 0 => signal power greater than noise threshold 1 => signal power is less than noise threshold
D10–D8	KCLFRQ	100	R/W	Keyclick Frequency 000 => 62.5 Hz 001 => 125 Hz 010 => 250 Hz 011 => 500 Hz 100 => 1 kHz 101 => 2 kHz 110 => 4 kHz 111 => 8 kHz
D7–D4	KCLLN	0001	R/W	Keyclick Length 0000 => 2 periods key click 0001 => 4 periods key click 0010 => 6 periods key click 0011 => 8 periods key click 0100 => 10 periods key click 0101 => 12 periods key click 0110 => 14 periods key click 0111 => 16 periods key click 1000 => 18 periods key click 1001 => 20 periods key click 1010 => 22 periods key click 1011 => 24 periods key click 1100 => 26 periods key click 1101 => 28 periods key click 1110 => 30 periods key click 1111 => 32 periods key click
D3	DLGAF	0	R	DAC Left Channel PGA Flag 0 => Gain applied ≠ PGA register setting 1 => Gain applied = PGA register setting. Note: This flag indicates when the soft–stepping for DAC left channel is completed
D2	DRGAF	0	R	DAC Right Channel PGA Flag 0 => Gain applied ≠ PGA register setting 1 => Gain applied = PGA register setting. Note: This flag indicates when the soft–stepping for DAC right channel is completed

BIT	NAME	RESET VALUE	READ/ WRITE	FUNCTION
D1	DASTC	0	R/W	DAC Channel PGA Soft–stepping control 0 => 0.5 dB change every WCLK 1 => 0.5 dB change every 2 WCLK
D0	ADGAF	0	R	Headset/Aux or Handset PGA Flag 1 => Gain applied = PGA register setting. 0 => Gain applied ≠ PGA Register setting Note: This flag indicates when the soft–stepping for PGA is completed. When AGC is enabled for Headset/Aux or Handset, this bit is read–only and acts as Saturation Flag. The read value of this bit indicates the following 0 => AGC is not saturated 1 => AGC is saturated (PGA has reached –12 dB or max PGA applicable).

REGISTER 05H: CODEC Power Control

BIT	NAME	RESET VALUE	READ/WRITE	FUNCTION
D15	MBIAS_HND	1	R/W	MICBIAS_HND Power–down Control 0 => MICBIAS_HND is powered up. 1 => MICBIAS_HND is powered down.
D14	MBIAS_HED	1	R/W	MICBIAS_HED Power–down Control 0 => MICBIAS_HED is powered up. 1 => MICBIAS_HED is powered down.
D13	ASTPWD	1	R/W	Analog Sidetone Power–down Control 0 => Analog sidetone powered up 1 => Analog sidetone powered down
D12	SP1PWDN	1	R/W	SPK1 (Single–Ended)/OUT32N (Differential) Power–down Control 0 => SPK1/OUT32N is powered up 1 => SPK1/OUT32N is powered down
D11	SP2PWDN	1	R/W	SPK2 Power–down Control 0 => SPK2 is powered up 1 => SPK2 is powered down
D10	DAPWDN	1	R/W	DAC Power–down Control 0 => DAC powered up 1 => DAC powered down
D9	ADPWDN	1	R/W	ADC Power–down Control 0 => ADC powered up 1 => ADC powered down
D8	VGPWDN	1	R/W	Driver Virtual Ground Power–down Control 0 => VGND is powered up 1 => VGND is powered down
D7	COPWDN	1	R/W	CP_OUT Power–down Control 0 => CP_OUT is powered up 1 => CP_OUT is powered down
D6	LSPWDN	1	R/W	Loudspeaker (8–Ω Driver) Power–down Control 0 => Loudspeaker (8–Ω driver) is powered up 1 => Loudspeaker (8–Ω driver) is powered down
D5	ADPWDF	1	R	ADC Power Down Flag 0 => ADC power down is not complete 1 => ADC power down is complete
D4	LDAPWDF	1	R	DAC Left Power Down Flag 0 => DAC left power down is not complete 1 => DAC left power down is complete
D3	RDAPWDF	1	R	DAC Right Power Down Flag 0 => DAC right power down is not complete 1 => DAC right power down is complete
D2	ASTPWF	1	R	Analog Sidetone Power Down Flag 0 => Analog sidetone power down is not complete 1 => Analog sidetone power down is complete

BIT	NAME	RESET VALUE	READ/WRITE	FUNCTION
D1	EFFCTL	0	R/W	Digital Audio Effects Filter 0 => Disable digital audio effects filter 1 => Enable digital audio effects filter
D0	DEEMPF	0	R/W	De-emphasis Filter Enable 0 => Disable de-emphasis filter 1 => Enable de-emphasis filter

NOTE: D15–D6 are all 1's, then full codec section is powered down.

REGISTER 06H: Audio Control 3

BIT	NAME	RESET VALUE	READ/WRITE	FUNCTION
D15–D14	DMSVOL	00	R/W	DAC Channel Master Volume Control 00 => Left channel and right channel have independent volume controls 01 => Left channel volume control is the programmed value of the right channel volume control. 10 => Right channel volume control is the programmed value of the left channel volume control. 11 => same as 00
D13	REFFS	0	R/W	Reference Sampling Rate Note: This setting controls the coefficients in the de-emphasis filter, the time-constants in AGC, and internal divider values that generate the clock for the touch screen measurement ADC. If an Fsref above 48 kHz is being used, then it is recommended to set this to the 48-kHz setting, otherwise either setting can be used. 0 => Fsref = 48.0 kHz 1 => Fsref = 44.1 kHz
D12	DAXFM	0	R/W	Master Transfer Mode 0 => Continuous data transfer mode 1 => 256-s data transfer mode
D11	SLVMS	0	R/W	CODEC Master Slave Selection 0 => The TSC2101 is slave codec 1 => The TSC2101 is master codec
D10–D9		0's	R	Reserved
D8	ADCOVF	0	R	ADC Channel Overflow Flag 0 => ADC channel data is within saturation limits 1 => ADC channel data has exceeded saturation limits. Note: This flag gets reset after register read.
D7	DALOVF	0	R	DAC Left Channel Overflow Flag 0 => DAC left channel data is within saturation limits 1 => DAC left channel data has exceeded saturation limits Note: This flag gets reset after register read.
D6	DAROVF	0	R	DAC Right Channel Overflow Flag 0 => DAC right channel data is within saturation limits 1 => DAC right channel data has exceeded saturation limits Note: This flag gets reset after register read.
D5–D4		00	R/W	Reserved.
D3	CLPST	0	R/W	MIC AGC Clip Stepping Disable 0 => Disabled 1 => Enabled Note: Valid only when AGC is selected for the Headset/Aux or Handset input.
D2–D0	REVID	XXX	R	TSC2101 Device Revision ID

REGISTER 07H: Digital Audio Effects Filter Coefficients

BIT	NAME	RESET VALUE (IN DECIMAL)	READ/WRITE	FUNCTION
D15–D0	L_N0	27619	R/W	Left channel bass-boost coefficient N0.

REGISTER 08H: Digital Audio Effects Filter Coefficients

BIT	NAME	RESET VALUE (IN DECIMAL)	READ/WRITE	FUNCTION
D15–D0	L_N1	–27034	R/W	Left channel bass-boost coefficient N1.

REGISTER 09H: Digital Audio Effects Filter Coefficients

BIT	NAME	RESET VALUE (IN DECIMAL)	READ/ WRITE	FUNCTION
D15–D0	L_N2	26461	R/W	Left channel bass-boost coefficient N2.

REGISTER 0AH: Digital Audio Effects Filter Coefficients

BIT	NAME	RESET VALUE (IN DECIMAL)	READ/ WRITE	FUNCTION
D15–D0	L_N3	27619	R/W	Left channel bass-boost coefficient N3.

REGISTER 0BH: Digital Audio Effects Filter Coefficients

BIT	NAME	RESET VALUE (IN DECIMAL)	READ/ WRITE	FUNCTION
D15–D0	L_N4	–27034	R/W	Left channel bass-boost coefficient N4.

REGISTER 0CH: Digital Audio Effects Filter Coefficients

BIT	NAME	RESET VALUE (IN DECIMAL)	READ/ WRITE	FUNCTION
D15–D0	L_N5	26461	R/W	Left channel bass-boost coefficient N5.

REGISTER 0DH: Digital Audio Effects Filter Coefficients

BIT	NAME	RESET VALUE (IN DECIMAL)	READ/ WRITE	FUNCTION
D15–D0	L_D1	32131	R/W	Left channel bass-boost coefficient D1.

REGISTER 0EH: Digital Audio Effects Filter Coefficients

BIT	NAME	RESET VALUE (IN DECIMAL)	READ/ WRITE	FUNCTION
D15–D0	L_D2	–31506	R/W	Left channel bass-boost coefficient D2.

REGISTER 0FH: Digital Audio Effects Filter Coefficients

BIT	NAME	RESET VALUE (IN DECIMAL)	READ/ WRITE	FUNCTION
D15–D0	L_D4	32131	R/W	Left channel bass-boost coefficient D4.

REGISTER 10H: Digital Audio Effects Filter Coefficients

BIT	NAME	RESET VALUE (IN DECIMAL)	READ/ WRITE	FUNCTION
D15–D0	L_D5	–31506	R/W	Left channel bass-boost coefficient D5.

REGISTER 11H: Digital Audio Effects Filter Coefficients

BIT	NAME	RESET VALUE (IN DECIMAL)	READ/ WRITE	FUNCTION
D15–D0	R_N0	27619	R/W	Right channel bass-boost coefficient N0.

REGISTER 12H: Digital Audio Effects Filter Coefficients

BIT	NAME	RESET VALUE (IN DECIMAL)	READ/ WRITE	FUNCTION
D15–D0	R_N1	–27034	R/W	Right channel bass-boost coefficient N1.

REGISTER 13H: Digital Audio Effects Filter Coefficients

BIT	NAME	RESET VALUE (IN DECIMAL)	READ/ WRITE	FUNCTION
D15–D0	R_N2	26461	R/W	Right channel bass-boost coefficient N2.

REGISTER 14H: Digital Audio Effects Filter Coefficients

BIT	NAME	RESET VALUE (IN DECIMAL)	READ/ WRITE	FUNCTION
D15–D0	R_N3	27619	R/W	Right channel bass-boost coefficient N3.

REGISTER 15H: Digital Audio Effects Filter Coefficients

BIT	NAME	RESET VALUE (IN DECIMAL)	READ/ WRITE	FUNCTION
D15–D0	R_N4	–27034	R/W	Right channel bass-boost coefficient N4.

REGISTER 16H: Digital Audio Effects Filter Coefficients

BIT	NAME	RESET VALUE (IN DECIMAL)	READ/ WRITE	FUNCTION
D15–D0	R_N5	26461	R/W	Right channel bass-boost coefficient N5.

REGISTER 17H: Digital Audio Effects Filter Coefficients

BIT	NAME	RESET VALUE (IN DECIMAL)	READ/ WRITE	FUNCTION
D15–D0	R_D1	32131	R/W	Right channel bass-boost coefficient D1.

REGISTER 18H: Digital Audio Effects Filter Coefficients

BIT	NAME	RESET VALUE (IN DECIMAL)	READ/ WRITE	FUNCTION
D15–D0	R_D2	–31506	R/W	Right channel bass-boost coefficient D2.

REGISTER 19H: Digital Audio Effects Filter Coefficients

BIT	NAME	RESET VALUE (IN DECIMAL)	READ/ WRITE	FUNCTION
D15–D0	R_D4	32131	R/W	Right channel bass-boost coefficient D4.

REGISTER 1AH: Digital Audio Effects Filter Coefficients

BIT	NAME	RESET VALUE (IN DECIMAL)	READ/ WRITE	FUNCTION
D15–D0	R_D5	–31506	R/W	Right channel bass-boost coefficient D5.

REGISTER 1BH: PLL Programmability

BIT	NAME	RESET VALUE	READ/WRITE	FUNCTION
D15	PLLSEL	0	R/W	PLL Enable 0 => Disable PLL. 1 => Enable PLL.
D14–D11	QVAL	0010	R/W	Q value: Valid when PLL is disabled 0000 => 16, 0001 => 17, 0010 => 2, 0011 => 3, 1100 => 12, 1101 => 13, 1110 => 14, 1111 => 15,
D10–D8	PVAL	000	R/W	P value: Valid when PLL is enabled 000 => 8, 001 => 1, 010 => 2, 011 => 3, 100 => 4, 101 => 5, 110 => 6, 111 => 7

D7–D2	J_VAL	000001	R/W	J value: Valid when PLL is enabled 000000 => Not valid, 000001 => 1, 000010 => 2, 000011 => 3, 111100 => 60, 111101 => 61, 111110 => 62, 111111 => 63
D1–D0		00	R	Reserved (Write only 00)

REGISTER ICH: PLL Programmability

BIT	NAME	RESET VALUE	READ/WRITE	FUNCTION
D15–D2	D_VAL	0 (decimal)	R/W	D value: Valid when PLL is enabled D value is valid from 0000 to 9999 in decimal. Greater than 9999 is treated as 9999.
D1–D0	Reserved	0	R	Reserved (Write only 00)

REGISTER IDH: Audio Control 4

BIT	NAME	RESET VALUE	READ/WRITE	FUNCTION
D15	ADSTPD	0	R/W	Headset/Aux or Handset PGA Soft-stepping Control 0 => Enable soft-stepping 1 => Disable soft-stepping
D14	DASTPD	0	R/W	DAC PGA Soft-stepping Control 0 => Enable soft-stepping 1 => Disable soft-stepping
D13	ASSTPD	0	R/W	Analog Sidetone PGA Soft-stepping Control 0 => Enable soft-stepping 1 => Disable soft-stepping Note: When soft-stepping is enabled gain is changed 0.5 dB per Fsref.
D12	CISTPD	0	R/W	Cell-phone PGA Soft-stepping Control 0 => Enable soft-stepping 1 => Disable soft-stepping Note: When soft-stepping is enabled gain is changed 0.5 dB per Fsref.
D11	BISTPD	0	R/W	Buzzer PGA Soft-stepping Control 0 => Enable soft-stepping 1 => Disable soft-stepping Note: When soft-stepping is enabled gain is changed 3 dB per Fsref.
D10–D9	AGCHYS	00	R/W	MIC AGC Hysteresis selection 00 => 1 dB 01 => 2 dB 10 => 4 dB 11 => No Hysteresis Note: Valid only when AGC is selected for Headset/Aux or Handset input
D8–D7	MB_HED	00	R/W	Micbias for Headset 00 => MICBIAS_HED = 3.3 V 01 => MICBIAS_HED = 2.5 V 10 => MICBIAS_HED = 2.0 V 11 => MICBIAS_HED = 2.0 V
D6	MB_HND	0	R/W	Micbias for Handset 0 => MICBIAS_HND = 2.5 V 1 => MICBIAS_HND = 2.0 V
D5–D2		0's	R	Reserved (Write only 0000)
D1	SCPFL	0	R	Driver Short Circuit Protection Flag. 0 => No short circuit happened. 1 => Short circuit detected on headphone outputs.
D0		X	R	Reserved (Write only 0)

REGISTER 1EH: Gain Control for Handset Input

BIT	NAME	RESET VALUE	READ/WRITE	FUNCTION																																																			
D15	ADMUT_HND	1	R/W	Handset Input Mute 1 => Handset Input Mute 0 => Handset Input not muted Note: If AGC is enabled and handset Input is selected then ADMUT_HND+ADPGA_HND will reflect gain being applied by AGC.																																																			
D14–D8	ADPGA_HND	1111111	R/W	ADC Handset PGA Settings 0000000 => 0 dB 0000001 => 0.5 dB 0000010 => 1.0 dB 1110110 => 59.0 dB 1111111 => 59.5 dB Note: If AGC is enabled and handset Input is selected then ADMUT_HND+ADPGA_HND will reflect gain being applied by AGC. If AGC is on, the decoding for read values is as follows 01110111 => +59.5 dB 01110110 => +59.0 dB 00000000 => 0 dB 11101000 => -12 dB																																																			
D7–D5	AGCTG_HND	000	R/W	AGC Target Gain for Handset Input. These three bits set the AGC's targeted ADC output level. 000 => -5.5 dB 001 => -8.0 dB 010 => -10 dB 011 => -12 dB 100 => -14 dB 101 => -17 dB 110 => -20 dB 111 => -24 dB																																																			
D4–D1	AGCTC_HND	0000	R/W	AGC Time Constant for Handset Input. These four bits set the AGC attack and decay time constants. Time constants remain the same irrespective of any sampling frequency. <table border="1" style="margin-left: 40px;"> <thead> <tr> <th></th> <th>Attack time (ms)</th> <th>Decay time (ms)</th> </tr> </thead> <tbody> <tr><td>0000</td><td>8</td><td>100</td></tr> <tr><td>0001</td><td>11</td><td>100</td></tr> <tr><td>0010</td><td>16</td><td>100</td></tr> <tr><td>0011</td><td>20</td><td>100</td></tr> <tr><td>0100</td><td>8</td><td>200</td></tr> <tr><td>0101</td><td>11</td><td>200</td></tr> <tr><td>0110</td><td>16</td><td>200</td></tr> <tr><td>0111</td><td>20</td><td>200</td></tr> <tr><td>1000</td><td>8</td><td>400</td></tr> <tr><td>1001</td><td>11</td><td>400</td></tr> <tr><td>1010</td><td>16</td><td>400</td></tr> <tr><td>1011</td><td>20</td><td>400</td></tr> <tr><td>1100</td><td>8</td><td>500</td></tr> <tr><td>1101</td><td>11</td><td>500</td></tr> <tr><td>1110</td><td>16</td><td>500</td></tr> <tr><td>1111</td><td>20</td><td>500</td></tr> </tbody> </table>		Attack time (ms)	Decay time (ms)	0000	8	100	0001	11	100	0010	16	100	0011	20	100	0100	8	200	0101	11	200	0110	16	200	0111	20	200	1000	8	400	1001	11	400	1010	16	400	1011	20	400	1100	8	500	1101	11	500	1110	16	500	1111	20	500
	Attack time (ms)	Decay time (ms)																																																					
0000	8	100																																																					
0001	11	100																																																					
0010	16	100																																																					
0011	20	100																																																					
0100	8	200																																																					
0101	11	200																																																					
0110	16	200																																																					
0111	20	200																																																					
1000	8	400																																																					
1001	11	400																																																					
1010	16	400																																																					
1011	20	400																																																					
1100	8	500																																																					
1101	11	500																																																					
1110	16	500																																																					
1111	20	500																																																					
D0	AGCEN_HND	0	R/W	AGC Enable for Handset Input 0 => AGC is off for Handset Input (ADC PGA is controlled by ADMUT_HND+ADPGA_HND) 1 => AGC is on for Handset Input (ADC PGA is controlled by AGC)																																																			

REGISTER 1FH: Gain Control for Cell Phone Input and Buzzer Input

BIT	NAME	RESET VALUE	READ/WRITE	FUNCTION
D15	MUT_CP	1	R/W	Cell phone Input PGA Power–down 1 => Power–down cell-phone input PGA 0 => Power–up cell phone input PGA
D14–D8	CPGA	1000101	R/W	Cell–phone Input PGA Settings. 0000000 => –34.5 dB 0000001 => –34 dB 0000010 => –33.5 dB ... 1000101 => 0 dB 1000110 => 0.5 dB ... 1011100 => 11.5 dB 1011101 => 12 dB 1011110 => 12 dB 1011111 => 12 dB 11xxxxx => 12 dB Note: These bits are read–only when AGC is enabled for CP_IN (cell-phone input) and reflect the gain applied by the AGC.
D7	CPGF	0	R	Cell phone Input PGA Flag (Read Only) 0 => Gain applied ≠ PGA register setting 1 => Gain applied = PGA register setting. Note: This flag indicates when the soft–stepping for cell-phone input is completed. When AGC is enabled for Cell–phone input, this bit is read–only and acts as Saturation Flag. The read value of this bit indicates the following 0 => AGC is not saturated 1 => AGC is saturated (PGA has reached –34.5 dB or max PGA applicable).
D6	MUT_BU	1	R/W	Buzzer Input PGA Power–down 1 => Power–down buzzer input PGA 0 => Power–up buzzer input PGA
D5–D2	BPGA	1111	R/W	Buzzer Input PGA settings. 1111 => 0 dB 1110 => –3 dB 1101 => –6 dB 1100 => –9 dB 1011 => –12 dB 1010 => –15 dB 1001 => –18 dB 1000 => –21 dB 0111 => –24 dB 0110 => –27 dB 0101 => –30 dB 0100 => –33 dB 0011 => –36 dB 0010 => –39 dB 0001 => –42 dB 0000 => –45 dB
D1	BUGF	0	R	Buzzer PGA Flag (Read Only) 0 => Gain Applied ≠ PGA Register setting 1 => Gain Applied = PGA register setting. Note: This flag indicates when the soft–stepping for buzzer input is completed.
D0		0	R	Reserved (Write only 0)

REGISTER 20H: Audio Control 5

BIT	NAME	RESET VALUE	READ/ WRITE	FUNCTION
D15	DIFFIN	0	R/W	Single-ended or Differential Output Selection. 0 => Single-ended output (headset/lineout) selected for SPK1 and SPK2 drivers 1 => Differential output (handset) selected for SPK1 and OUT32N drivers Note: When bit D15=1, both SPK1 and OUT32N drivers should be power-up. Otherwise the TSC2101 automatically power-down both SPK1 and OUT32N drivers.
D14–D13	DAC2SPK1	00	R/W	DAC Channel Routing to SPK1 (Single-ended)/ SPK1–OUT32N (Differential) 00 => No routing from DAC to SPK1/ SPK1–OUT32N 01 => DAC left routed to SPK1/SPK1–OUT32N 10 => DAC right routed to SPK1/SPK1–OUT32N 11 => DAC (left + right)/2 routed to SPK1/SPK1–OUT32N
D12	AST2SPK1	0	R/W	Analog Sidetone Routing to SPK1 (Single-ended)/SPK1–OUT32N (Differential) 0 => No routing from analog sidetone to SPK1/SPK1–OUT32N 1 => Analog sidetone routed to SPK1/SPK1–OUT32N
D11	BUZ2SPK1	0	R/W	Buzzer PGA Routing to SPK1 (Single-ended)/ SPK1–OUT32N (Differential) 0 => No routing from buzzer PGA to SPK1/SPK1–OUT32N 1 => Buzzer PGA routed to SPK1/ SPK1–OUT32N
D10	KCL2SPK1	0	R/W	Keyclick Routing to SPK1 (Single-ended)/SPK1–OUT32N (Differential) 0 => No routing from keyclick to SPK1/SPK1–OUT32N 1 => Keyclick routed to SPK1/SPK1–OUT32N
D9	CPI2SPK1	0	R/W	Cell–phone Input Routing to SPK1 (Single-ended)/SPK1–OUT32N (Differential) 0 => No routing from cell-phone input to SPK1/SPK1–OUT32N 1 => Cell phone input routed to SPK1/SPK1–OUT32N
D8–D7	DAC2SPK2	00	R/W	DAC Channel Routing to SPK2 (Valid for Only Single-ended) 00 => No routing from DAC to SPK2 01 => DAC left routed to SPK2 10 => DAC right routed to SPK2 11 => DAC (left + right)/2 routed to SPK2
D6	AST2SPK2	0	R/W	Analog Sidetone Routing to SPK2 (Valid for Only Single-ended) 0 => No routing from analog sidetone to SPK2 1 => Analog sidetone routed to SPK2
D5	BUZ2SPK2	0	R/W	Buzzer PGA Routing to SPK2 (Valid for Only Single-ended) 0 => No routing from buzzer PGA to SPK2 1 => Buzzer PGA routed to SPK2
D4	KCL2SPK2	0	R/W	Keyclick Routing to SPK2 (Valid for Only Single-ended) 0 => No routing from keyclick to SPK2 1 => Keyclick routed to SPK2
D3	CPI2SPK2	0	R/W	Cell–phone Input Routing to SPK2 (Valid for Only Single-ended) 0 => No routing from cell-phone input to SPK2 1 => Cell–phone input routed to SPK2
D2	MUTSPK1	1	R/W	Mute Control for SPK1 (Single-ended)/SPK1–OUT32N (Differential) 0 => SPK1/SPK1–OUT32N is not muted. 1 => SPK1/SPK1–OUT32N is muted.
D1	MUTSPK2	1	R/W	Mute Control for SPK2 (Valid for Only Single-ended) 0 => SPK2 is not muted. 1 => SPK2 is muted.
D0	HDSCPTC	0	W	Headphone Short–circuit Protection Control 0 => Enable short–circuit protection 1 => Disable short–circuit protection

REGISTER 21H: Audio Control 6

BIT	NAME	RESET VALUE	READ/WRITE	FUNCTION
D15	SPL2LSK	0	R/W	Routing Selected for SPK1 Goes to OUT8P–OUT8N (Loudspeaker) Also. 0 => None of the routing selected for SPK1 goes to OUT8P–OUT8N. 1 => Routing selected for SPK1 using D14–D9 of control register 20H/page 2 goes to OUT8P–OUT8N. Note: This programming is valid only if SPK1/OUT32N and SPK2 are powered down.
D14	AST2LSK	0	R/W	Analog Sidetone Routing to OUT8P–OUT8N (Loudspeaker) 0 => No routing from analog sidetone to OUT8P–OUT8N 1 => Analog sidetone routed to OUT8P–OUT8N
D13	BUZ2LSK	0	R/W	Buzzer PGA Routing to OUT8P–OUT8N (Loudspeaker) 0 => No routing from buzzer PGA to OUT8P–OUT8N 1 => Buzzer PGA routed to OUT8P–OUT8N
D12	KCL2LSK	0	R/W	Keyclick Routing to OUT8P–OUT8N (Loudspeaker) 0 => No routing from keyclick to OUT8P–OUT8N 1 => Keyclick routed to OUT8P–OUT8N
D11	CPI2LSK	0	R/W	Cell–phone Input Routing to OUT8P–OUT8N (Loudspeaker) 0 => No routing from cell–phone input to OUT8P–OUT8N 1 => Cell–phone input routed to OUT8P–OUT8N
D10	MIC2CPO	0	R/W	MICSEL (Programmed Using Control Register 04H/Page 2) Routed to Cell–phone Output. 0 => No routing from MICSEL to CP_OUT. 1 => MICSEL routed to CP_OUT.
D9	SPL2CPO	0	R/W	Routing Selected for SPK1 (Other Than Cell–phone Input) Goes to Cell–phone Output Also. 0 => None of the routing selected for SPK1 goes to cell–phone output. 1 => Routing selected for SPK1 using D14–D10 of control register 20H/page 2 goes to CP_OUT. Note: This programming is valid even if SPK1/OUT32N and SPK2 are powered down.
D8	SPR2CPO	0	R/W	Routing Selected for SPK2 Goes to Cell–phone Output Also (Valid for Only Single-ended). 0 => None of the routing selected for SPK2 goes to cell–phone output. 1 => Routing selected for SPK2 using D8–D3 of control register 20H/page2 goes to CP_OUT. Note: 1. This programming is valid even if SPK2 is power-down. 2. This programming is not valid when routing selected for SPK1 is routed to loudspeaker
D7	MUTLSPK	1	R/W	Mute Control for OUT8P–OUT8N Loudspeaker 0 => OUT8P–OUT8N is not muted. 1 => OUT8P–OUT8N is muted.
D6	MUTSPK2	1	R/W	Mute Control for Cell–phone Output 0 => CPOUT is not muted. 1 => CPOUT is muted.
D5	LDSCPTC	1	R/W	Loudspeaker Short–circuit Protection Control 0 => Enable short–circuit protection for loudspeaker 1 => Disable short–circuit protection for loudspeaker
D4	VGNDSCPTC	0	R/W	VGND Short–circuit Protection Control 0 => Enable short–circuit protection for VGND driver 1 => Disable short–circuit protection for VGND driver
D3	CAPINTF	0	R/W	Cap/Cap–less Interface Select for Headset. 0 => Select cap–less interface. 1 => Select cap interface.
D2–D0		0's	R	Reserved (Write only 000)

REGISTER 22H: Audio Control 7

BIT	NAME	RESET VALUE	READ/ WRITE	FUNCTION
D15	DETECT	0	R/W	Headset Detection 0 => Disable headset detection 1 => Enable headset detection
D14–D13	HESTYPE	00	R	Type of Headset Detected. 00 => No headset detected. 01 => Stereo headset detected. 10 => Cellular headset detected 11 => Stereo+cellular headset detected Note: These two bits are valid only if the headset detection is enabled.
D12	HDDETFL	0	R	Headset Detection Flag. 0 => Headset is not detected 1 => Headset is detected.
D11	BDETFL	0	R	Button Press Detection Flag. 0 => Button press is not detected 1 => Button press is detected.
D10–D9	HDDEBNPG	01	R/W	De–bouncing Programmability for Glitch Rejection During Headset Detection. 00 => 16 ms duration (with 2 ms clock resolution) 01 => 32 ms duration (with 4 ms clock resolution) 10 => 64 ms duration (with 8 ms clock resolution) 11 => 128 ms duration (with 16 ms clock resolution)
D8		0	R	Reserved (Write only 0)
D7–D6	BDEBNPG	00	R/W	De–bouncing Programmability for Glitch Rejection During Button Press Detection. 00 => No glitch rejection. 01 => 8 ms duration (with 1 ms clock resolution) 10 => 16 ms duration (with 2 ms clock resolution) 11 => 32 ms duration (with 4 ms clock resolution)
D5		0	R	Reserved (Write only 0)
D4	DGPIO2	0	R/W	Enable GPIO2 for Headset Detection Interrupt 0 => Disable GPIO2 for headset detection interrupt 1 => Enable GPIO2 for headset detection interrupt Note: This programmability is valid only if D15 and D13 of control register 23H/page 2 are set to 0
D3	DGPIO1	0	R/W	Enable GPIO1 for Headset Detection Interrupt 0 => Disable GPIO1 for Detection interrupt 1 => Enable GPIO1 for Detection interrupt Note: This programmability is valid only if D11 and D9 of control register 23H/page 2 are set to 0
D2	CLKGPIO2	0	R/W	Enable GPIO2 for CLKOUT 0 => Disable GPIO2 for CLKOUT mode. 1 => Enable GPIO2 for CLKOUT mode. In CLKOUT mode the frequency of output signal is equal to the 256xDAC_FS if DAC_FS is faster than ADC_FS otherwise equal to the 256xADC_FS. Note: This programmability is valid only if PLL is enabled, D15 and D13 of register 23H/page 2 are set to 0 and GPIO2 is not enabled for detection interrupt.
D1–D0	ADWSF	00	R/W	ADWS Selection 0X => GPIO1 pin output is three–stated. 10 => GPIO1 pin acts as button press detect interrupt. 11 => GPIO1 pin acts as ADC word–select (ADWS). Note: 1. This programmability is valid only if D11 and D9 of control register 23H/page 2 are set to 0. 2. These bits should be programmed '11' only if different ADC and DAC sample rates are desired. In this mode WCLK acts as DAWS i.e. DAC sample rate and GPIO1 acts as ADWS i.e. ADC sample rate.

REGISTER 23H: GPIO Control

BIT	NAME	RESET VALUE	READ/ WRITE	FUNCTION
D15	GPO2EN	0	R/W	GPIO2 Enable for General Purpose Output Port 0 => GPIO2 is not programmed as general purpose output port 1 => GPIO2 programmed as general purpose output port
D14	GPO2SG	0	R/W	GPIO2 Output Signal Programmability 0 => GPIO2 goes to low if GPIO2 enable for general purpose output port 1 => GPIO2 goes to high if GPIO2 enable for general purpose output port
D13	GPI2EN	0	R/W	GPIO2 Enable for General Purpose Input Port 0 => GPIO2 is not programmed as general purpose input port 1 => GPIO2 programmed as general purpose input port
D12	GPI2SGF	0	R	GPIO2 Input Signal Flag 0 => GPIO2 input is low. 1 => GPIO2 input is high. Note: Valid only if GPIO2 is enable for general purpose input port
D11	GPO1EN	0	R/W	GPIO1 Enable for General Purpose Output Port 0 => GPIO1 is not programmed as general purpose output port 1 => GPIO1 programmed as general purpose output port
D10	GPO1SG	0	R/W	GPIO1 Output Signal Programmability 0 => GPIO1 goes to low if GPIO1 enable for general purpose output port 1 => GPIO1 goes to high if GPIO1 enable for general purpose output port
D9	GPI1EN	0	R/W	GPIO1 Enable for General Purpose Input Port 0 => GPIO1 is not programmed as general purpose input port 1 => GPIO1 programmed as general purpose input port
D8	GPI1SGF	0	R	GPIO1 Input Signal Flag 0 => GPIO1 input is low. 1 => GPIO1 input is high. Note: Valid only if GPIO1 is enable for general purpose input port
D7–D0		0	R	Reserved (Write only 00000000)

REGISTER 24H: AGC for Cell-Phone Input Control

BIT	NAME	RESET VALUE	READ/ WRITE	FUNCTION
D15		0	R	Reserved (Write only 0)
D14	AGCNF_CELL	0	R	Noise Threshold Flag. The read values indicate the following 0 => Signal power greater than noise threshold 1 => Signal power is less than noise threshold Note: Valid only if AGC is selected for the Cell–phone input (CP_IN).
D13–D11	AGCNL	000	R/W	AGC Noise Threshold. These settings apply to both Headset/Aux/Handset and Cell–phone input. 000 => –30 dB 001 => –30 dB 010 => –40 dB 011 => –50 dB 100 => –60 dB 101 => –70 dB (not valid for Cell–phone AGC) 110 => –80 dB (not valid for Cell–phone AGC) 111 => –90 dB (not valid for Cell–phone AGC)
D10–D9	AGCHYS_CELL	00	R/W	AGC Hysteresis Selection for Cell–phone Input 00 => 1 dB 01 => 2 dB 10 => 4 dB 11 => No Hysteresis
D8	CLPST_CELL	0	R/W	AGC Clip Stepping Disable for Cell–phone Input 0 => Disable clip stepping for cell-phone input 1 => Enable clip stepping for cell-phone input

BIT	NAME	RESET VALUE	READ/ WRITE	FUNCTION																																																			
D7–D5	AGCTG_CELL	000	R/W	AGC Target Gain for Cell–phone Input. These three bits set the AGC’s targeted ADC output level. 000 => –5.5 dB 001 => –8.0 dB 010 => –10 dB 011 => –12 dB 100 => –14 dB 101 => –17 dB 110 => –20 dB 111 => –24 dB																																																			
D4–D1	AGCTC_CELL	0000	R/W	AGC Time Constant for Cell Input. These four bits set the AGC attack and decay time constants. Time constants remain the same irrespective of any sampling frequency <table border="1" style="margin-left: 40px;"> <thead> <tr> <th></th> <th>Attack time (ms)</th> <th>Decay time (ms)</th> </tr> </thead> <tbody> <tr><td>0000</td><td>8</td><td>10</td></tr> <tr><td>0001</td><td>11</td><td>100</td></tr> <tr><td>0010</td><td>16</td><td>100</td></tr> <tr><td>0011</td><td>20</td><td>100</td></tr> <tr><td>0100</td><td>8</td><td>200</td></tr> <tr><td>0101</td><td>11</td><td>200</td></tr> <tr><td>0110</td><td>16</td><td>200</td></tr> <tr><td>0111</td><td>20</td><td>200</td></tr> <tr><td>1000</td><td>8</td><td>400</td></tr> <tr><td>1001</td><td>11</td><td>400</td></tr> <tr><td>1010</td><td>16</td><td>400</td></tr> <tr><td>1011</td><td>20</td><td>400</td></tr> <tr><td>1100</td><td>8</td><td>500</td></tr> <tr><td>1101</td><td>11</td><td>500</td></tr> <tr><td>1110</td><td>16</td><td>500</td></tr> <tr><td>1111</td><td>20</td><td>500</td></tr> </tbody> </table>		Attack time (ms)	Decay time (ms)	0000	8	10	0001	11	100	0010	16	100	0011	20	100	0100	8	200	0101	11	200	0110	16	200	0111	20	200	1000	8	400	1001	11	400	1010	16	400	1011	20	400	1100	8	500	1101	11	500	1110	16	500	1111	20	500
	Attack time (ms)	Decay time (ms)																																																					
0000	8	10																																																					
0001	11	100																																																					
0010	16	100																																																					
0011	20	100																																																					
0100	8	200																																																					
0101	11	200																																																					
0110	16	200																																																					
0111	20	200																																																					
1000	8	400																																																					
1001	11	400																																																					
1010	16	400																																																					
1011	20	400																																																					
1100	8	500																																																					
1101	11	500																																																					
1110	16	500																																																					
1111	20	500																																																					
D0	AGCEN_CELL	0	R/W	AGC Enable for Cell–phone Input 0 => AGC is off for Cell–phone input 1 => AGC is on for Cell–phone input (Cell PGA is controlled by AGC)																																																			

REGISTER 25H: Driver Power-Down Status

Note: All values reflected in control register 25H/page2 are valid only if short circuit is not detected (bit D1 of control register 1DH/page2 is set to 0)

BIT	NAME	RESET VALUE	READ/ WRITE	FUNCTION
D15	SPK1FL	1	R	SPK1 Driver Power-down Status 0 => SPK1 driver not powered down. 1 => SPK1 driver powered down.
D14	SPK2FL	1	R	SPK2 Driver Power-down Status 0 => SPK2 driver not powered down. 1 => SPK2 driver powered down.
D13	HNDFL	1	R	OUT32N (Handset) Driver Power-down Status 0 => OUT32N driver not powered down. 1 => OUT32N driver powered down.
D12	VGNDFL	1	R	VGND Driver Power-down Status 0 => VGND driver not powered down. 1 => VGND driver powered down.
D11	LSPKFL	1	R	Loudspeaker Driver Power-down Status 0 => Loudspeaker driver not powered down. 1 => Loudspeaker driver powered down.
D10	CELLFL	1	R	Cell–phone Output (CP_OUT) Driver Power-down Status 0 => Cell–phone output driver not powered down. 1 => Cell–phone output driver powered down.

SLAS392D–JUNE 2003 – REVISED MAY 2005

BIT	NAME	RESET VALUE	READ/ WRITE	FUNCTION
D9–D6		0000	R	Reserved (Write only 0000)
D5	PSEQ	0	R/W	Disable Drivers (SPK1/SPK2/OUT32N/VGND) Pop Sequencing 0 => Enable drivers pop sequencing 1 => Disable drivers pop sequencing
D4	PSTIME	0	R/W	Drivers (SPK1/SPK2) Pop Sequencing Duration in Cap Mode 0 => 802 ms. 1 => 4006 ms.
D3–D0		0000	R	Reserved (Write only 0000)

REGISTER 26H: Mic AGC Control

BIT	NAME	RESET VALUE	READ/ WRITE	FUNCTION
D15–D9	MMPGA	1111111	R/W	Max PGA Value Applicable for Headset/Aux or Handset AGC 0000000 => 0 dB 0000001 => 0.5 dB 0000010 => 1.0 dB 1110110 => 59.0 dB 1111111 => 59.5 dB
D8–D6	MDEBNS	000	R/W	Debounce Time for Transition from Normal Mode to Silence Mode (Input Level is Below Noise Threshold Programmed by AGCNL). This is Valid for Headset/Aux or Handset AGC. 000 => 0 ms 001 => 0.5 ms 010 => 1.0 ms 011 => 2.0 ms 100 => 4.0 ms 101 => 8.0 ms 110 => 16.0 ms 111 => 32.0 ms
D5–D3	MDEBSN	000	R/W	De–bounce Time for Transition from Silence Mode to Normal Mode. This is Valid for Headset/Aux or Handset AGC. 000 => 0 ms 001 => 0.5 ms 010 => 1.0 ms 011 => 2.0 ms 100 => 4.0 ms 101 => 8.0 ms 110 => 16.0 ms 111 => 32.0 ms
D2–D0		000	R	Reserved (Write only 000)

REGISTER 27H: Cell-Phone AGC Control

BIT	NAME	RESET VALUE	READ/ WRITE	FUNCTION
D15–D9	CMPGA	1111111	R/W	Max. Cell–phone input PGA value applicable for Cell–phone AGC 0000000 => –34.5 dB 0000001 => –34 dB 0000010 => –33.5 dB ... 1000100 => –0.5 dB 1000101 => invalid 1000110 => invalid ... 1011100 => Invalid 1011101 => 12 dB 1011110 => 12 dB 1011111 => 12 dB 11xxxxx => 12 dB
D8–D6	CDEBNS	000	R	De–bounce Time for Transition from Normal Mode to Silence Mode (Input Level is Below Noise Threshold Programmed by AGCNL). This is Valid for Cell–phone AGC. 000 => 0 ms 001 => 0.5 ms 010 => 1.0 ms 011 => 2.0 ms 100 => 4.0 ms 101 => 8.0 ms 110 => 16.0 ms 111 => 32.0 ms
D5–D3	CDEBSN	000	R	De–bounce Time for Transition from Silence Mode to Normal Mode. This is Valid for Cell–phone AGC. 000 => 0 ms 001 => 0.5 ms 010 => 1.0 ms 011 => 2.0 ms 100 => 4.0 ms 101 => 8.0 ms 110 => 16.0 ms 111 => 32.0 ms
D2–D0		000	R	Reserved (Write only 000)

TSC2101 Buffer Data Registers (Page 3)

The buffer data registers of the TSC2101 hold data results from the SAR ADC conversions in buffer mode. Upon reset, bit D15 is set to 0, bit D14 is set to 1 and the remaining bits are don't-care. These registers are *read only*.

If buffer mode is enabled, then the results of all ADC conversions are placed in the buffer data register. The data format of the result word (R) of these registers is right-justified which is as follows:

D15 MSB	D14	D13	D12	D11	D10	D9	D8	D7	D6	D5	D4	D3	D2	D1	D0 LSB
FUF	EMF	X	ID	R11 MSB	R10	R9	R8	R7	R6	R5	R4	R3	R2	R1	R0 LSB

BIT	NAME	RESET VALUE	READ/ WRITE	FUNCTION
D15	FUF	0	R	Buffer Full Flag This flag indicates that all the 64 locations of the buffer are having unread data.
D14	EMF	1	R	Buffer Empty Flag This flag indicates that there is no unread data available in FIFO. This is generated while reading the last converted data.
D13		X	R	Reserved

BIT	NAME	RESET VALUE	READ/ WRITE	FUNCTION
D12	ID	X	R	Data Identification 0 => X or Z1 coordinate or BAT or AUX2 data in R11–R0 1 => Y or Z2 coordinate or AUX1 or TEMP data in R11–R0 Order for Writing Data in Buffer When Multiple Inputs are Selected For XY Conversion: Y, X For XYZ1Z2 Conversion: Y, X, Z1, Z2 For Z1Z2 Conversion: Z1, Z2 For Auto Scan Conversion: AUX1 (if selected), AUX2 (if selected), TEMP (if selected) For Port Scan Conversion: BAT, AUX1, AUX2
D11–D0	R11–R0	X's	R	Converted Data

LAYOUT

The following layout suggestions should provide optimum performance from the TSC2101. However, many portable applications have conflicting requirements concerning power, cost, size, and weight. In general, most portable devices have fairly *clean* power and grounds because most of the internal components are very low power. This situation would mean less bypassing for the converter's power and less concern regarding grounding. Still, each situation is unique and the following suggestions should be reviewed carefully.

For optimum performance, care should be taken with the physical layout of the TSC2101 circuitry. The basic SAR architecture is sensitive to glitches or sudden changes on the power supply, reference, ground connections, and digital inputs that occur just prior to latching the output of the analog comparator. Therefore, during any single conversion for an *n-bit* SAR converter, there are *n windows* in which large external transient voltages can easily affect the conversion result. Such glitches might originate from switching power supplies, nearby digital logic, and high power devices. The degree of error in the digital output depends on the reference voltage, layout, and the exact timing of the external event. The error can change if the external event changes in time with respect to the timing of the critical *n windows*.

With this in mind, power to the TSC2101 should be clean and well bypassed. A 0.1 μF ceramic bypass capacitor should be placed as close to the device as possible. A 1 μF to 10 μF capacitor may also be needed if the impedance of the connection between the TSC2101 supply pins and system power supply is high.

A bypass capacitor on the VREF pin is generally not needed because the reference is buffered by an internal op amp, although it can be useful to reduce reference noise level. If an external reference voltage originates from an op amp, make sure that it can drive any bypass capacitor that is used without oscillation.

The TSC2101 architecture offers no inherent rejection of noise or voltage variation in regards to using an external reference input. This is of particular concern when the reference input is tied to the power supply. Any noise and ripple from the supply appears directly in the digital results. While high frequency noise can be filtered out, voltage variation due to line frequency (50 Hz or 60 Hz) can be difficult to remove.

The ground pins should be connected to a clean ground point. In many cases, this is the *analog* ground. Avoid connections, which are too near the grounding point of a microcontroller or digital signal processor. If needed, run a ground trace directly from the converter to the power supply entry or battery connection point. The ideal layout includes an analog ground plane dedicated to the converter and associated analog circuitry.

In the specific case of use with a resistive touch screen, care should be taken with the connection between the converter and the touch screen. Since resistive touch screens have fairly low resistance, the interconnection should be as short and robust as possible. Loose connections can be a source of error when the contact resistance changes with flexing or vibrations.

As indicated previously, noise can be a major source of error in touch-screen applications (e.g., applications that require a back-lit LCD panel). This EMI noise can be coupled through the LCD panel to the touch screen and cause *flickering* of the converted ADC data. Several things can be done to reduce this error, such as utilizing a touch screen with a bottom–side metal layer connected to ground. This couples the majority of noise to ground. Additionally, filtering capacitors, from Y+, Y–, X+, and X– to ground, can also help. Note, however, that the use of these capacitors increases screen settling time and require longer panel voltage stabilization times, as well as increased precharge and sense times for the $\overline{\text{PINTDAV}}$ circuitry of the TSC2101.

CONVERSION TIME CALCULATIONS FOR THE TSC2101

Touch Screen Conversion Initiated at Touch Detect

The time needed to get a converted X/Y coordinate for reading can be calculated by (not including the time needed to send the command over the SPI bus):

$$t_{\text{coordinate}} = 2 \times \left[\frac{(t_{\text{PRE}} + t_{\text{SNS}} + t_{\text{PVS}})}{125 \text{ ns}} \right] \times t_{\text{OSC}} + 2 \times \left\{ N_{\text{AVG}} \left[(N_{\text{BITS}} + 1) \times \frac{8 \text{ MHz}}{f_{\text{conv}}} + n_1 + 12 \right] + 1 \right\} \\ \times t_{\text{OSC}} + 18 \times t_{\text{OSC}} + n_2 \times t_{\text{OSC}} + n_3 \times t_{\text{OSC}}$$

where:

$t_{\text{coordinate}}$ = time to convert X/Y coordinate

t_{PVS} = Panel voltage stabilization time

t_{PRE} = precharge time

t_{SNS} = sense time

N_{AVG} = number of averages; for no averaging, $N_{\text{AVG}} = 1$

N_{BITS} = number of bits of resolution

f_{conv} = A/D converter clock frequency

t_{OSC} = Oscillator clock period

$n_1 = 6$; if $f_{\text{conv}} = 8 \text{ MHz}$

7 ; if $f_{\text{conv}} \neq 8 \text{ MHz}$

$n_2 = 4$; if $t_{\text{PVS}} = 0 \mu\text{s}$

0 ; if $t_{\text{PVS}} \neq 0 \mu\text{s}$

$n_3 = 0$; if $t_{\text{SNS}} = 32 \mu\text{s}$

2 ; if $t_{\text{SNS}} \neq 32 \mu\text{s}$

t_{PGDEL} = Programmable delay in between conversion for touch screen measurement

= 0: if programmable delay mode is disabled for touch screen measurement

(1) t_{PGDEL} delay is generated by using: Internal oscillator clock whose typical frequency is 1 MHz, in internal clock mode, or MCLK/CLKDIV (as programmed in control register 14H/page1) in external clock mode.

(2) The above formula is valid exactly only when the codec is powered down. Also after touch detect the formula holds true from second conversion onwards.

(3) If D15–D14 of control register 01H/page 1 = 00, then in case of continuous touch $\overline{\text{PINTDAV}}$ remains high for $(t_{\text{PRE}} + t_{\text{SNS}}) \times t_{\text{OSC}} / 125 \text{ ns}$. If D15–D14 of control register 01H/page 1 = 10/11, then in case of continuous touch $\overline{\text{PINTDAC}}$ remains high for $(t_{\text{PRE}} + t_{\text{SNS}}) \times t_{\text{OSC}} / 125 \text{ ns} + t_{\text{PGDEL}}$.

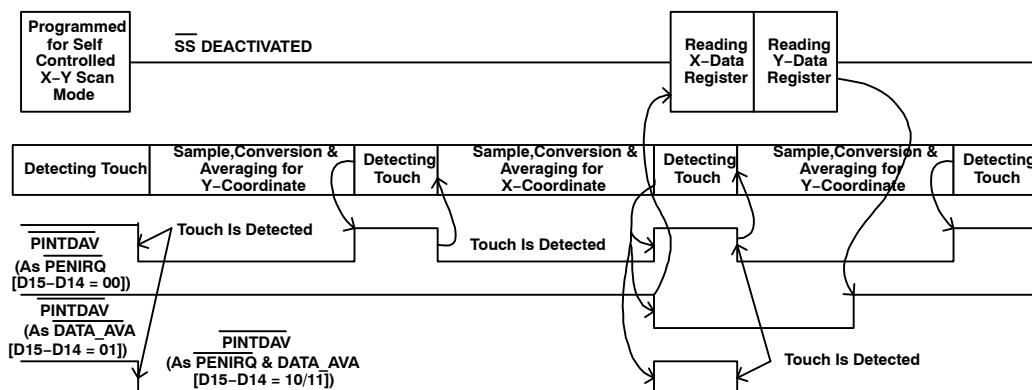

The time for a complete X/Y/Z1/Z2 coordinate conversion is given by(not including the time needed to send the command over the SPI bus):

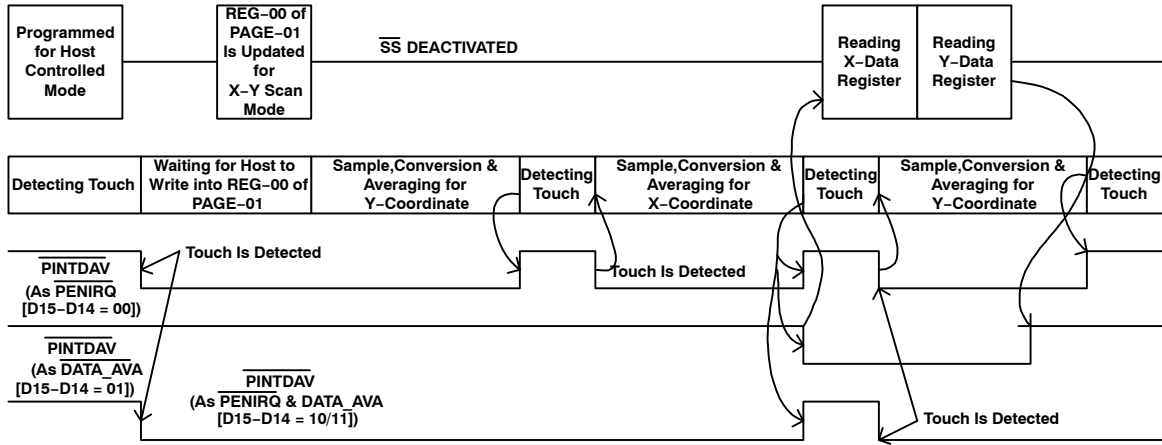

$$t_{\text{coordinate}} = 3 \times \left[\frac{(t_{\text{PRE}} + t_{\text{SNS}} + t_{\text{PVS}})}{125 \text{ ns}} \right] \times t_{\text{OSC}} + 4 \times \left\{ N_{\text{AVG}} \left[(N_{\text{BITS}} + 1) \times \frac{8 \text{ MHz}}{f_{\text{conv}}} + n_1 + 12 \right] + 1 \right\} \times t_{\text{OSC}} + 33 \times t_{\text{OSC}} + n_2 \times t_{\text{OSC}} + n_3 \times t_{\text{OSC}} + t_{\text{PGDEL}}$$

$$n_1 = 6 ; \text{ if } f_{\text{conv}} = 8 \text{ MHz}$$

$$7 ; \text{ if } f_{\text{conv}} \neq 8 \text{ MHz}$$

$$n_2 = 4 ; \text{ if } t_{\text{PVS}} = 0 \mu\text{s}$$

$$0 ; \text{ if } t_{\text{PVS}} \neq 0 \mu\text{s}$$

$$n_3 = 0 ; \text{ if } t_{\text{SNS}} = 32 \mu\text{s}$$

$$3 ; \text{ if } t_{\text{SNS}} \neq 32 \mu\text{s}$$

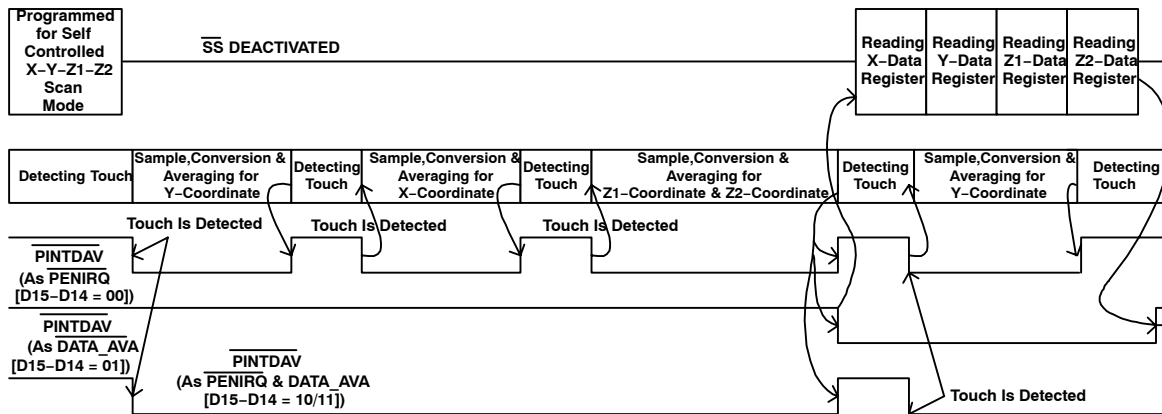

The time needed to convert any single coordinate either X or Y under self-controlled (not including the time needed to send the command over the SPI bus) is given by:

$$t_{\text{coordinate}} = \left[\frac{(t_{\text{PRE}} + t_{\text{SNS}} + t_{\text{PVS}})}{125 \text{ ns}} \right] \times t_{\text{OSC}} + \left\{ N_{\text{AVG}} \left[(N_{\text{BITS}} + 1) \times \frac{8 \text{ MHz}}{f_{\text{conv}}} + n_1 + 12 \right] + 1 \right\} \times t_{\text{OSC}} + 16 \times t_{\text{OSC}} + n_2 \times t_{\text{OSC}} + n_3 \times t_{\text{OSC}} + t_{\text{PGDEL}}$$

$$n_1 = 6 ; \text{ if } f_{\text{conv}} = 8 \text{ MHz}$$

$$7 ; \text{ if } f_{\text{conv}} \neq 8 \text{ MHz}$$

$n_2 = 2$; if $t_{PVS} = 0 \mu s$
 0 ; if $t_{PVS} \neq 0 \mu s$
 $n_3 = 0$; if $t_{SNS} = 32 \mu s$
 0 ; if $t_{SNS} \neq 32 \mu s$

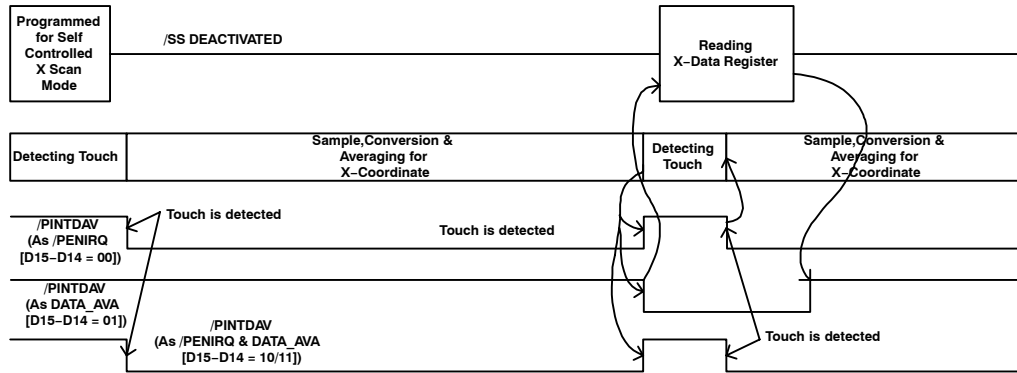

The time needed to convert the Z coordinate under self-controlled mode (not including the time needed to send the command over the SPI bus) is given by:

$$t_{\text{coordinate}} = \left[\frac{(t_{\text{PRE}} + t_{\text{SNS}} + t_{\text{PVS}})}{125 \text{ ns}} \right] \times t_{\text{OSC}} + 2 \times \left\{ N_{\text{AVG}} \left[(N_{\text{BITS}} + 1) \times \frac{8 \text{ MHz}}{f_{\text{conv}}} + n_1 + 12 \right] + 1 \right\} \\ \times t_{\text{OSC}} + 22 \times t_{\text{OSC}} + n_2 \times t_{\text{OSC}} + n_3 \times t_{\text{OSC}} + t_{\text{PGDEL}}$$

$n_1 = 6$; if $f_{\text{conv}} = 8 \text{ MHz}$
 7 ; if $f_{\text{conv}} \neq 8 \text{ MHz}$
 $n_2 = 2$; if $t_{PVS} = 0 \mu s$
 0 ; if $t_{PVS} \neq 0 \mu s$
 $n_3 = 0$; if $t_{SNS} = 32 \mu s$
 1 ; if $t_{SNS} \neq 32 \mu s$

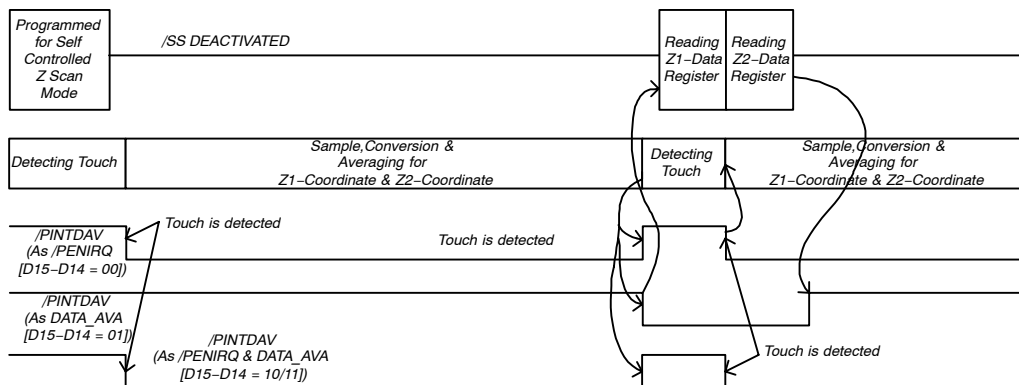

Touch Screen Conversion Initiated by the Host

The time needed to convert any single coordinate either X or Y under host-controlled mode (not including the time needed to send the command over the SPI bus) is given by:

$$t_{\text{coordinate}} = \left[\frac{t_{\text{PVS}}}{125 \text{ ns}} \right] \times t_{\text{OSC}} + \left\{ N_{\text{AVG}} \left[\left(N_{\text{BITS}} + 1 \right) \times \frac{8 \text{ MHz}}{f_{\text{conv}}} + n_1 + 12 \right] + 1 \right\} \times t_{\text{OSC}} + 14 \times t_{\text{OSC}} + n_2 \times t_{\text{OSC}}$$

$n_1 = 6$; if $f_{\text{conv}} = 8 \text{ MHz}$

7 ; if $f_{\text{conv}} \neq 8 \text{ MHz}$

$n_2 = 2$; if $t_{\text{PVS}} = 0 \mu\text{s}$

0 ; if $t_{\text{PVS}} \neq 0 \mu\text{s}$

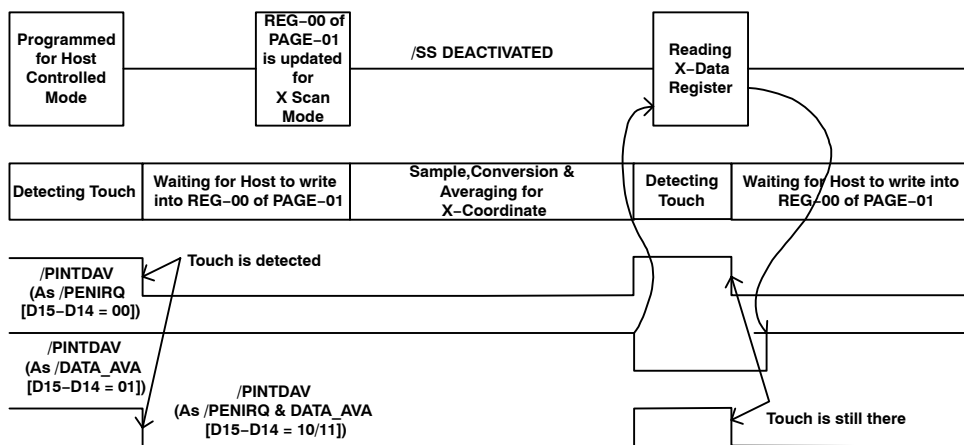

$$t_{\text{coordinate}} = \left[\frac{t_{\text{PVS}}}{125 \text{ ns}} \right] \times t_{\text{OSC}} + 2 \times \left\{ N_{\text{AVG}} \left[\left(N_{\text{BITS}} + 1 \right) \times \frac{8 \text{ MHz}}{f_{\text{conv}}} + n_1 + 12 \right] + 1 \right\} \times t_{\text{OSC}} + 20 \times t_{\text{OSC}} + n_2 \times t_{\text{OSC}}$$

$n_1 = 6$; if $f_{\text{conv}} = 8 \text{ MHz}$

7 ; if $f_{\text{conv}} \neq 8 \text{ MHz}$

$n_2 = 2$; if $t_{\text{PVS}} = 0 \mu\text{s}$

0 ; if $t_{\text{PVS}} \neq 0 \mu\text{s}$

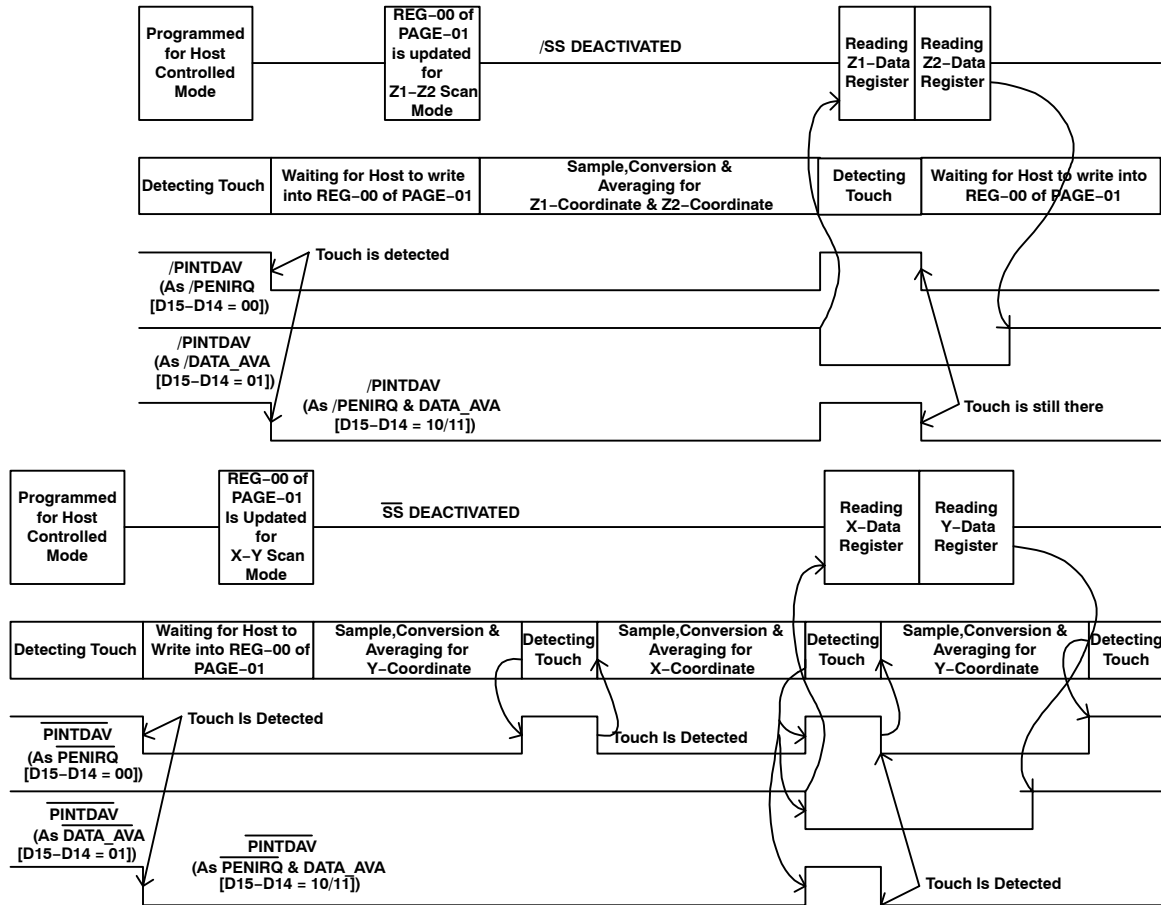

Non-Touch Screen Measurement Operation

The time needed to make temperature, auxiliary, or battery measurements is given by:

$$t = \left\{ N_{AVG} \left[\left(N_{BITS} + 1 \right) \times \frac{8 \text{ MHz}}{f_{conv}} + n_1 + n_2 \right] + 1 \right\} \times t_{OSC} + 15 \times t_{OSC} + n_3 \times t_{OSC}$$

where:

$$n_1 = 6 ; \text{ if } f_{conv} = 8 \text{ MHz}$$

$$7 ; \text{ if } f_{conv} \neq 8 \text{ MHz}$$

$$n_2 = 24 ; \text{ if measurement is for TEMP1 case}$$

$$12 ; \text{ if measurement is for other than TEMP1 case}$$

$$400 \text{ ns}; \text{ if measurement is for the external/internal resistance using AUX1/AUX2}$$

$$n_3 = 0 ; \text{ if external reference mode is selected}$$

$$3 ; \text{ if } t_{REF} = 0 \mu\text{s} \text{ or reference is programmed for power up all the time.}$$

$$1 + t_{REF} / 125 \text{ ns}; \text{ if } t_{REF} \neq 0 \mu\text{s} \text{ and reference needs to power down between conversions.}$$

$$t_{REF} \text{ is the reference power up delay time.}$$

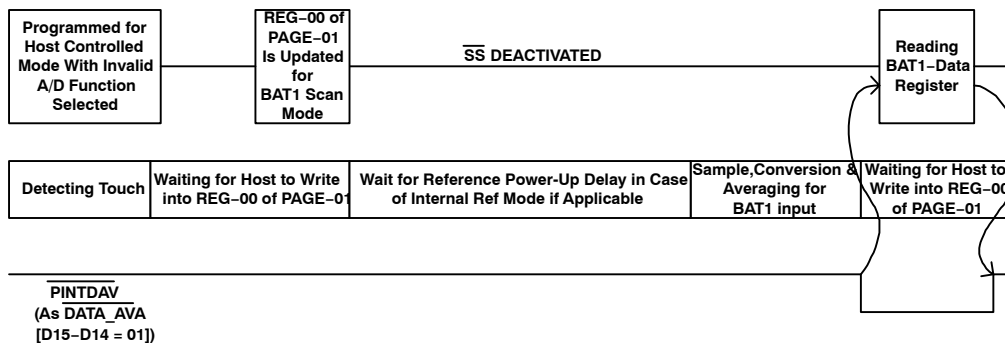

The time needed for continuous autoscan mode is given by:

$$t = N_{INP} \times \left(\left\{ N_{AVG} \left[\left(N_{BITS} + 1 \right) \times \frac{8 \text{ MHz}}{f_{conv}} + n_1 + 12 \right] + 1 \right\} \times t_{OSC} + 8 \times t_{OSC} \right) + n_2 \times t_{OSC} + t_{DEL} + n_3 \times t_{OSC} + n_4 \times t_{OSC}$$

where:

- $N_{INP} = 1$; if autoscan is selected for only one input AUX1, AUX2, TEMP1 or TEMP2
 - $= 2$; if autoscan is selected for two inputs AUX1–AUX2, AUX1–TEMP1, AUX1–TEMP2 etc
 - $= 3$; if autoscan is selected for three inputs AUX1–AUX2–TEMP1 or AUX1–AUX2–TEMP2
 - $n_1 = 6$; if $f_{conv} = 8 \text{ MHz}$
 - 7 ; if $f_{conv} \neq 8 \text{ MHz}$
 - $n_2 = 12$; if one of the input selected is TEMP1
 - 0 ; if measurement is for other than TEMP1
 - $n_3 = 0$; if external reference mode is selected or $t_{DEL} = 0$.
 - 3 ; if $t_{REF} = 0 \text{ ms}$ or reference is programmed for power up all the times.
 - $1 + t_{REF}/125 \text{ ns}$; if $t_{REF} \neq 0 \text{ us}$ and reference needs to power down between conversions.
- t_{REF} is the reference power up delay time.
- $n_4 = 0$; if $t_{DEL} = 0$.
 - $= 7$; if $t_{DEL} \neq 0$
- $t_{DEL} =$ Programmable delay in between conversion for nontouchscreen measurement
- $= 0$; if programmable delay mode is disabled for nontouchscreen measurement

- (1) The above equation is valid only from second conversion onwards.
- (2) t_{DEL} delay is generated by using internal oscillator clock whose typical frequency is 1 MHz in internal clock mode, or MCLK/CLKDIV (as programmed in control register 14H/page 1) in external clock mode.

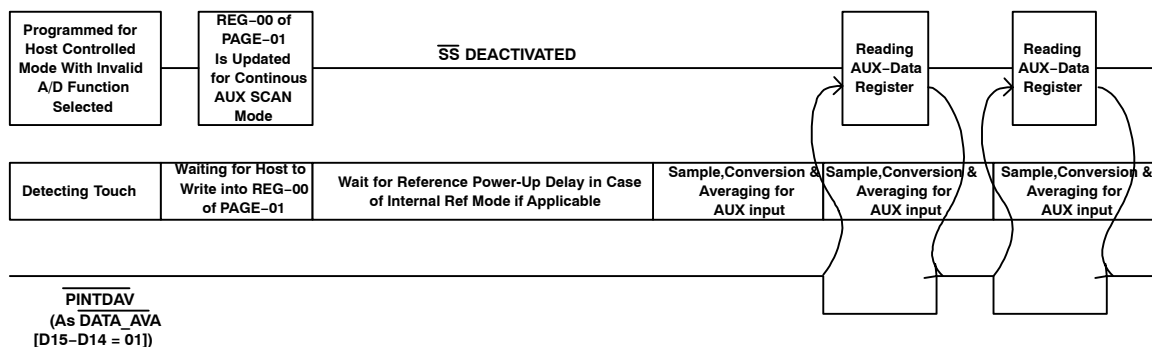

Port Scan Operation

The time needed to complete one set of port scan conversions is given by:

$$t_{\text{coordinate}} = 3 \times \left\{ N_{\text{AVG}} \left[(N_{\text{BITS}} + 1) \times \frac{8 \text{ MHz}}{f_{\text{conv}}} + n_1 + 12 \right] + 1 \right\} \times t_{\text{OSC}} + 31 \times t_{\text{OSC}} + n_2 \times t_{\text{OSC}}$$

where:

$n_1 = 6$; if $f_{\text{conv}} = 8 \text{ MHz}$

7 ; if $f_{\text{conv}} \neq 8 \text{ MHz}$

$n_2 = 0$; if external reference mode is selected

3 ; if $t_{\text{REF}} = 0 \mu\text{s}$ or reference is programmed for power up all the time.

1 + $t_{\text{REF}} / 125 \text{ ns}$; if $t_{\text{REF}} \neq 0 \mu\text{s}$ and reference needs to power down between conversions.

t_{REF} is the reference power up delay time.

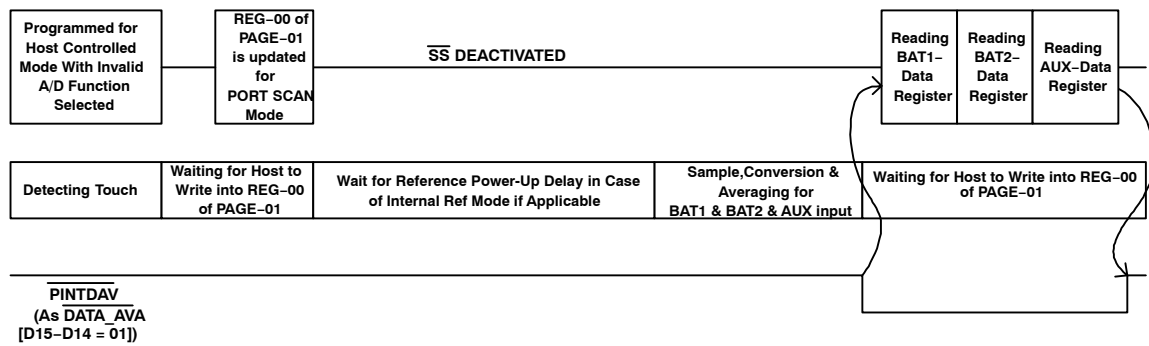

ADC CHANNEL DIGITAL FILTER FREQUENCY RESPONSES

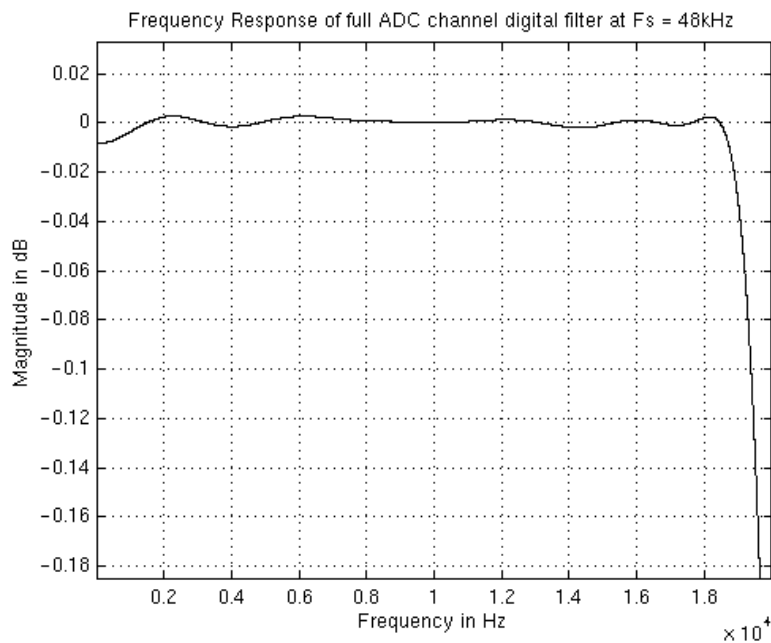

Figure 39. Pass-Band Frequency Response of ADC Digital Filter

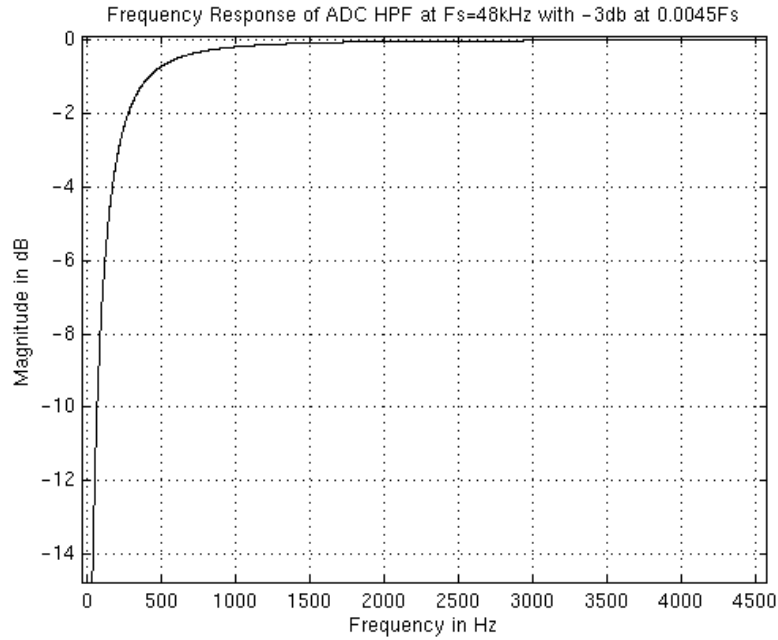

Figure 40. Frequency Response of ADC High-Pass Filter ($F_{\text{cutoff}} = 0.0045 F_s$)

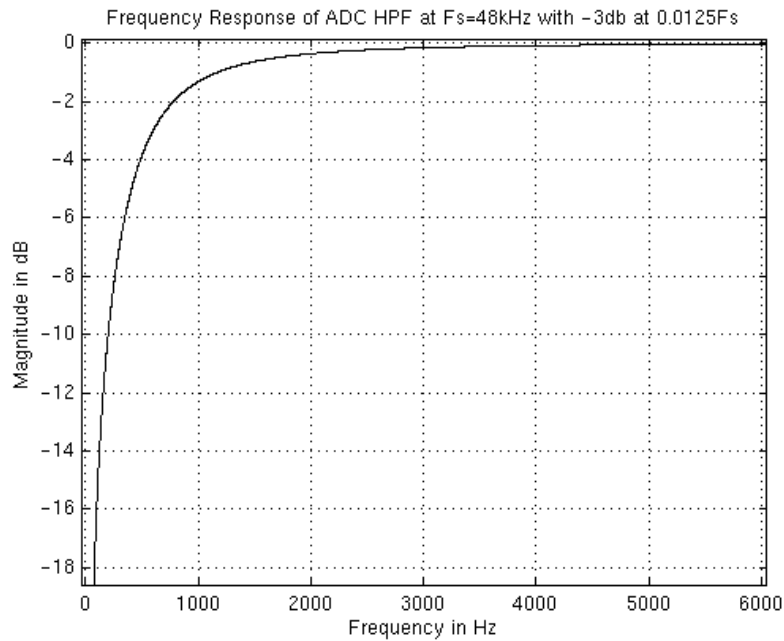

Figure 41. Frequency Response of ADC High-Pass Filter ($F_{\text{cutoff}} = 0.0125 F_s$)

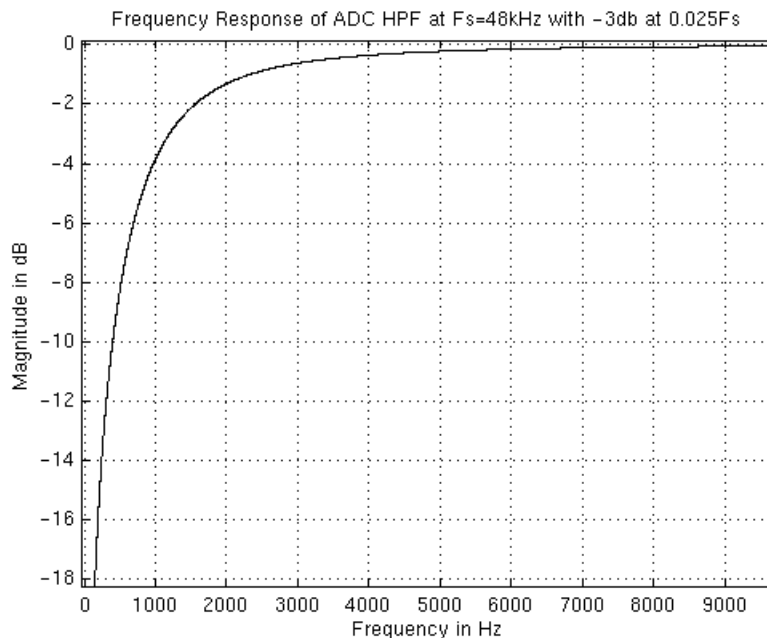

Figure 42. Frequency Response of ADC High-Pass Filter ($F_{\text{cutoff}} = 0.025 F_s$)

DAC CHANNEL DIGITAL FILTER FREQUENCY RESPONSES

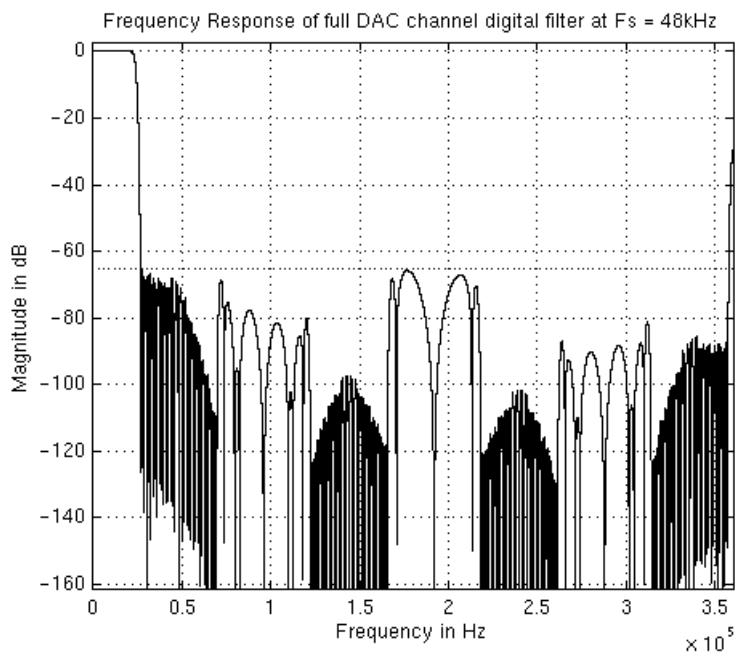

Figure 43. DAC Channel Digital Filter Frequency Response

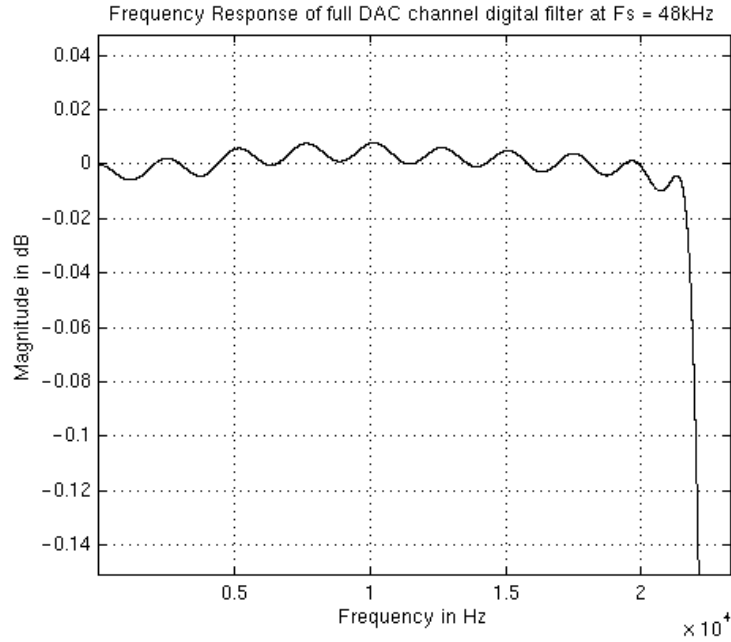

Figure 44. DAC Channel Digital Filter Pass-Band Frequency Response

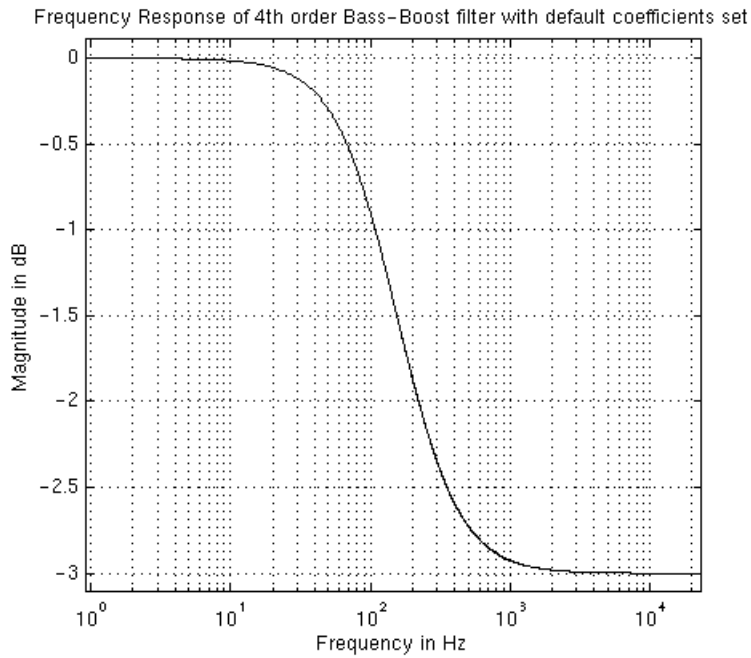

Figure 45. Default Digital Audio Effects Filter Frequency Response at 48 Ksps

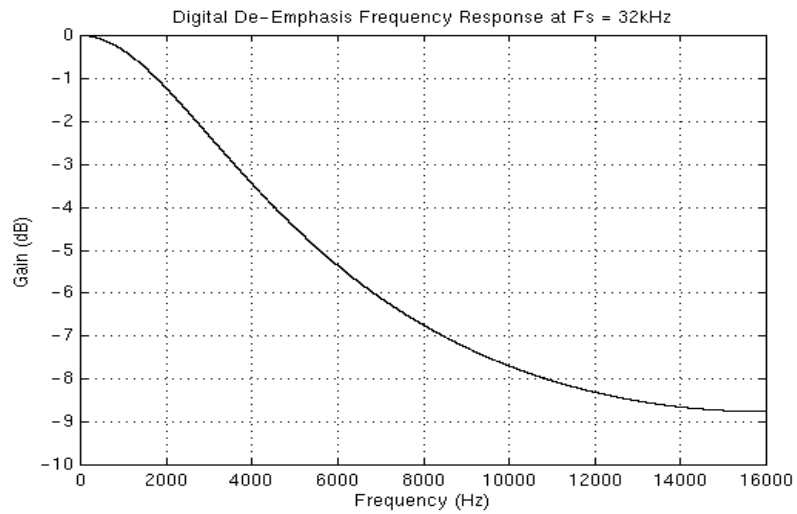

Figure 46. De-Emphasis Filter Response at 32 Ksps

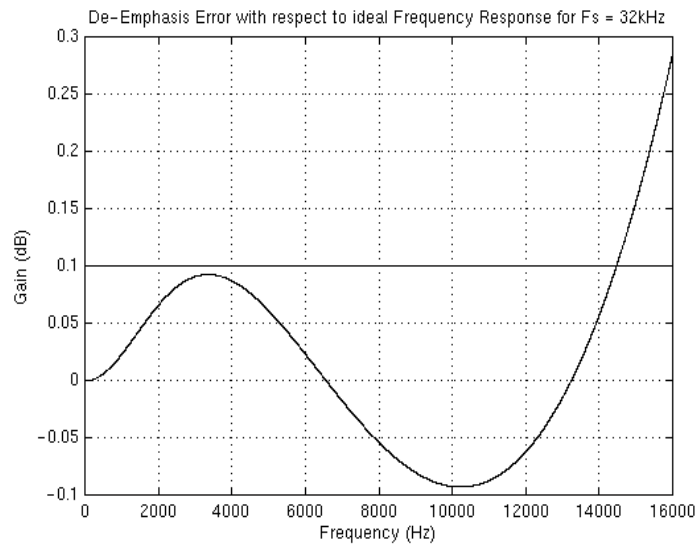

Figure 47. De-Emphasis Error at 32 Ksps

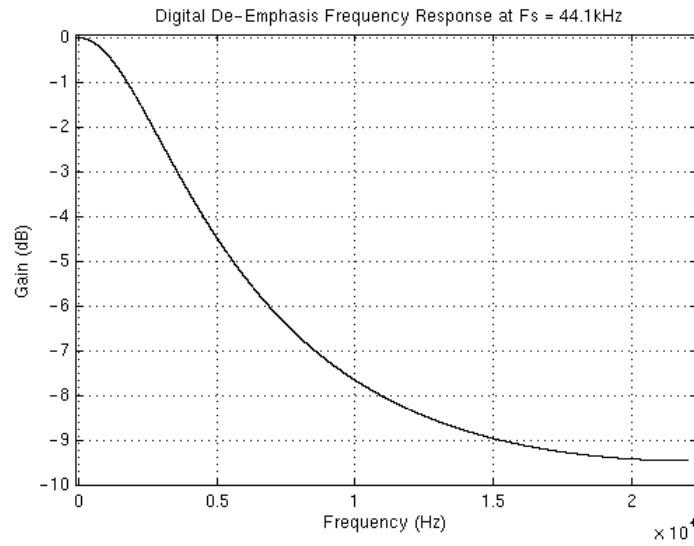

Figure 48. De-Emphasis Filter Frequency Response at 44.1 Ksps

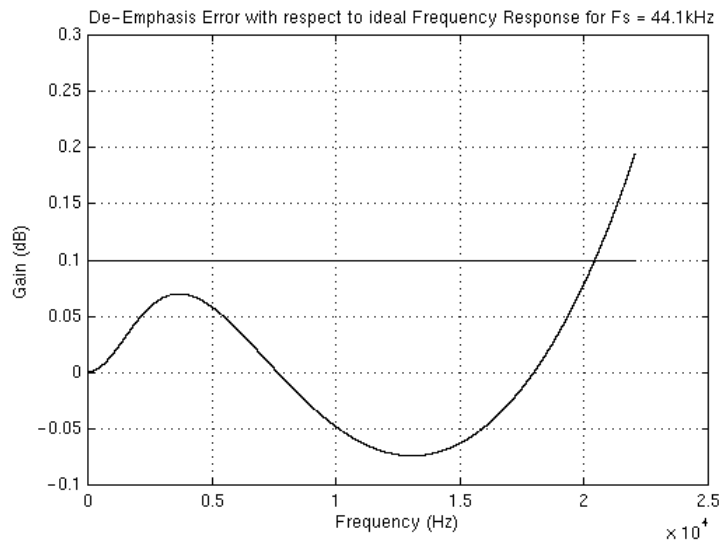

Figure 49. De-Emphasis Error at 44.1 Ksps

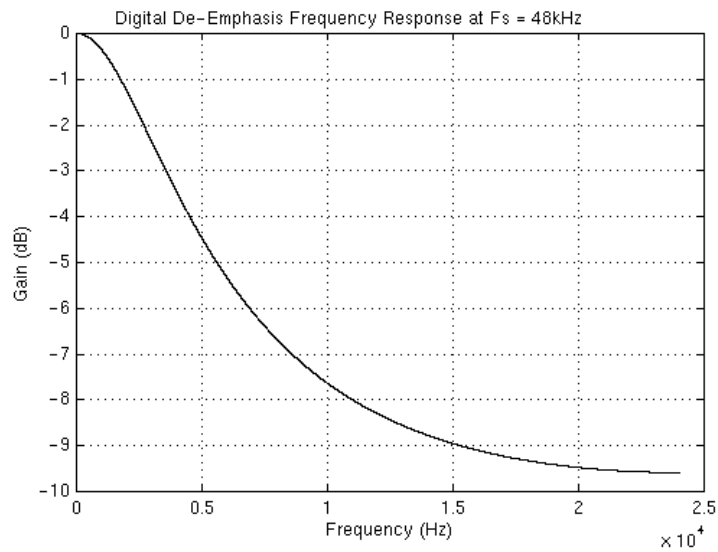

Figure 50. De-Emphasis Frequency Response at 48 Ksps

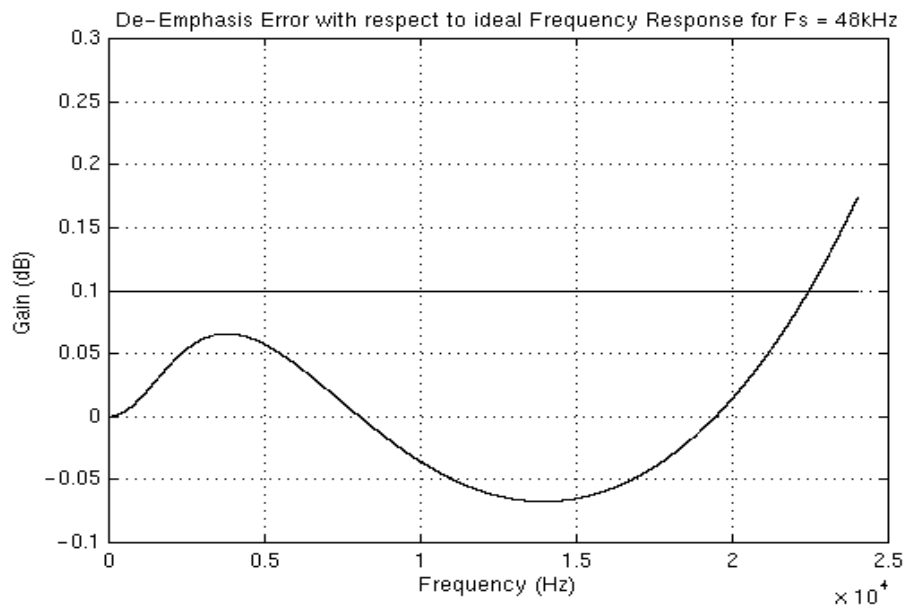

Figure 51. De-Emphasis Error at 48 Ksps

PLL PROGRAMMING

The on-chip PLL in the TSC2101 can be used to generate sampling clocks from a wide range of MCLK's available in a system. The PLL works by generating oversampled clocks with respect to Fsref (44.1 kHz or 48 kHz). Frequency division generates all other internal clocks. Table 7 and Table 8 gives a sample programming for PLL registers for some standard MCLK's when PLL is required. Whenever the MCLK is of the form of $N \times 128 \times \text{Fsref}$ ($N=2,3,\dots$), the PLL is not required.

Table 7. Fsref = 44.1 kHz

MCLK (MHz)	P	J	D	ACHIEVED FSREF	% ERROR
2.8224	1	32	0	44100.00	0.0000
5.6448	1	16	0	44100.00	0.0000
12	1	7	5264	44100.00	0.0000
13	1	6	9474	44099.71	0.0007
16	1	5	6448	44100.00	0.0000
19.2	1	4	7040	44100.00	0.0000
19.68	1	4	5893	44100.30	-0.0007
48	4	7	5264	44100.00	0.0000

Table 8. Fsref = 48 kHz

MCLK (MHz)	P	J	D	ACHIEVED FSREF	% ERROR
2.048	1	48	0	48000.00	0.0000
3.072	1	32	0	48000.00	0.0000
4.096	1	24	0	48000.00	0.0000
6.144	1	16	0	48000.00	0.0000
8.192	1	12	0	48000.00	0.0000
12	1	8	1920	48000.00	0.0000
13	1	7	5618	47999.71	0.0006
16	1	6	1440	48000.00	0.0000
19.2	1	5	1200	48000.00	0.0000
19.68	1	4	9951	47999.79	0.0004
48	4	8	1920	48000.00	0.0000

PACKAGING INFORMATION

Orderable Device	Status ⁽¹⁾	Package Type	Package Drawing	Pins	Package Qty	Eco Plan ⁽²⁾	Lead/Ball Finish	MSL Peak Temp ⁽³⁾
TSC2101IRGZ	ACTIVE	VQFN	RGZ	48	52	Green (RoHS & no Sb/Br)	Call TI	Level-2-260C-1 YEAR
TSC2101IRGZG4	ACTIVE	VQFN	RGZ	48	52	Green (RoHS & no Sb/Br)	Call TI	Level-2-260C-1 YEAR
TSC2101IRGZR	ACTIVE	VQFN	RGZ	48	2500	Green (RoHS & no Sb/Br)	Call TI	Level-2-260C-1 YEAR
TSC2101IRGZRG4	ACTIVE	VQFN	RGZ	48	2500	Green (RoHS & no Sb/Br)	Call TI	Level-2-260C-1 YEAR

⁽¹⁾ The marketing status values are defined as follows:

ACTIVE: Product device recommended for new designs.

LIFEBUY: TI has announced that the device will be discontinued, and a lifetime-buy period is in effect.

NRND: Not recommended for new designs. Device is in production to support existing customers, but TI does not recommend using this part in a new design.

PREVIEW: Device has been announced but is not in production. Samples may or may not be available.

OBSOLETE: TI has discontinued the production of the device.

⁽²⁾ Eco Plan - The planned eco-friendly classification: Pb-Free (RoHS), Pb-Free (RoHS Exempt), or Green (RoHS & no Sb/Br) - please check <http://www.ti.com/productcontent> for the latest availability information and additional product content details.

TBD: The Pb-Free/Green conversion plan has not been defined.

Pb-Free (RoHS): TI's terms "Lead-Free" or "Pb-Free" mean semiconductor products that are compatible with the current RoHS requirements for all 6 substances, including the requirement that lead not exceed 0.1% by weight in homogeneous materials. Where designed to be soldered at high temperatures, TI Pb-Free products are suitable for use in specified lead-free processes.

Pb-Free (RoHS Exempt): This component has a RoHS exemption for either 1) lead-based flip-chip solder bumps used between the die and package, or 2) lead-based die adhesive used between the die and leadframe. The component is otherwise considered Pb-Free (RoHS compatible) as defined above.

Green (RoHS & no Sb/Br): TI defines "Green" to mean Pb-Free (RoHS compatible), and free of Bromine (Br) and Antimony (Sb) based flame retardants (Br or Sb do not exceed 0.1% by weight in homogeneous material)

⁽³⁾ MSL, Peak Temp. -- The Moisture Sensitivity Level rating according to the JEDEC industry standard classifications, and peak solder temperature.

Important Information and Disclaimer:The information provided on this page represents TI's knowledge and belief as of the date that it is provided. TI bases its knowledge and belief on information provided by third parties, and makes no representation or warranty as to the accuracy of such information. Efforts are underway to better integrate information from third parties. TI has taken and continues to take reasonable steps to provide representative and accurate information but may not have conducted destructive testing or chemical analysis on incoming materials and chemicals. TI and TI suppliers consider certain information to be proprietary, and thus CAS numbers and other limited information may not be available for release.

In no event shall TI's liability arising out of such information exceed the total purchase price of the TI part(s) at issue in this document sold by TI to Customer on an annual basis.

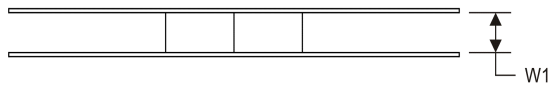
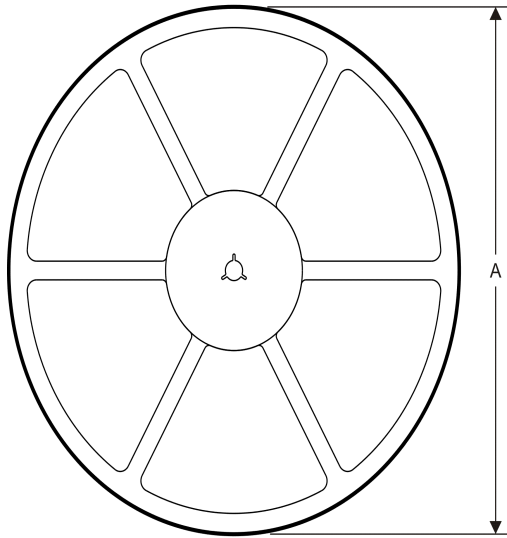
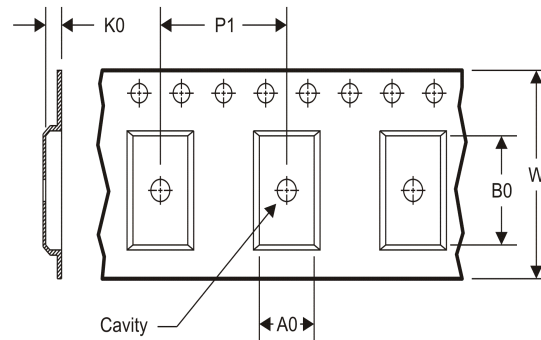
TAPE AND REEL INFORMATION
REEL DIMENSIONS

TAPE DIMENSIONS

A0	Dimension designed to accommodate the component width
B0	Dimension designed to accommodate the component length
K0	Dimension designed to accommodate the component thickness
W	Overall width of the carrier tape
P1	Pitch between successive cavity centers

TAPE AND REEL INFORMATION

*All dimensions are nominal

Device	Package Type	Package Drawing	Pins	SPQ	Reel Diameter (mm)	Reel Width W1 (mm)	A0 (mm)	B0 (mm)	K0 (mm)	P1 (mm)	W (mm)	Pin1 Quadrant
TSC2101IRGZR	VQFN	RGZ	48	2500	330.0	16.4	7.3	7.3	1.5	12.0	16.0	Q2

TAPE AND REEL BOX DIMENSIONS

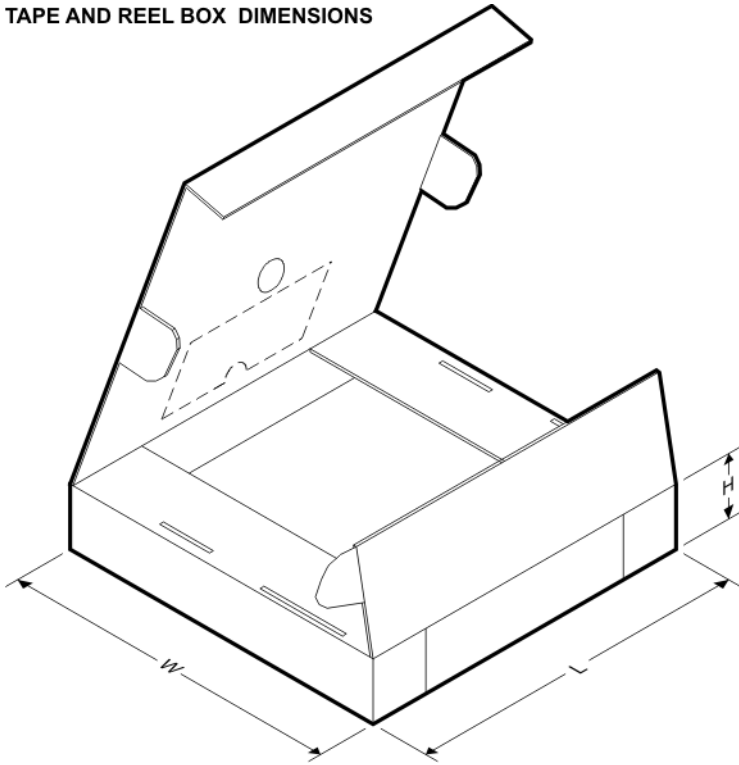

*All dimensions are nominal

Device	Package Type	Package Drawing	Pins	SPQ	Length (mm)	Width (mm)	Height (mm)
TSC2101IRGZR	VQFN	RGZ	48	2500	336.6	336.6	28.6

RGZ (S-PVQFN-N48)

PLASTIC QUAD FLATPACK NO-LEAD

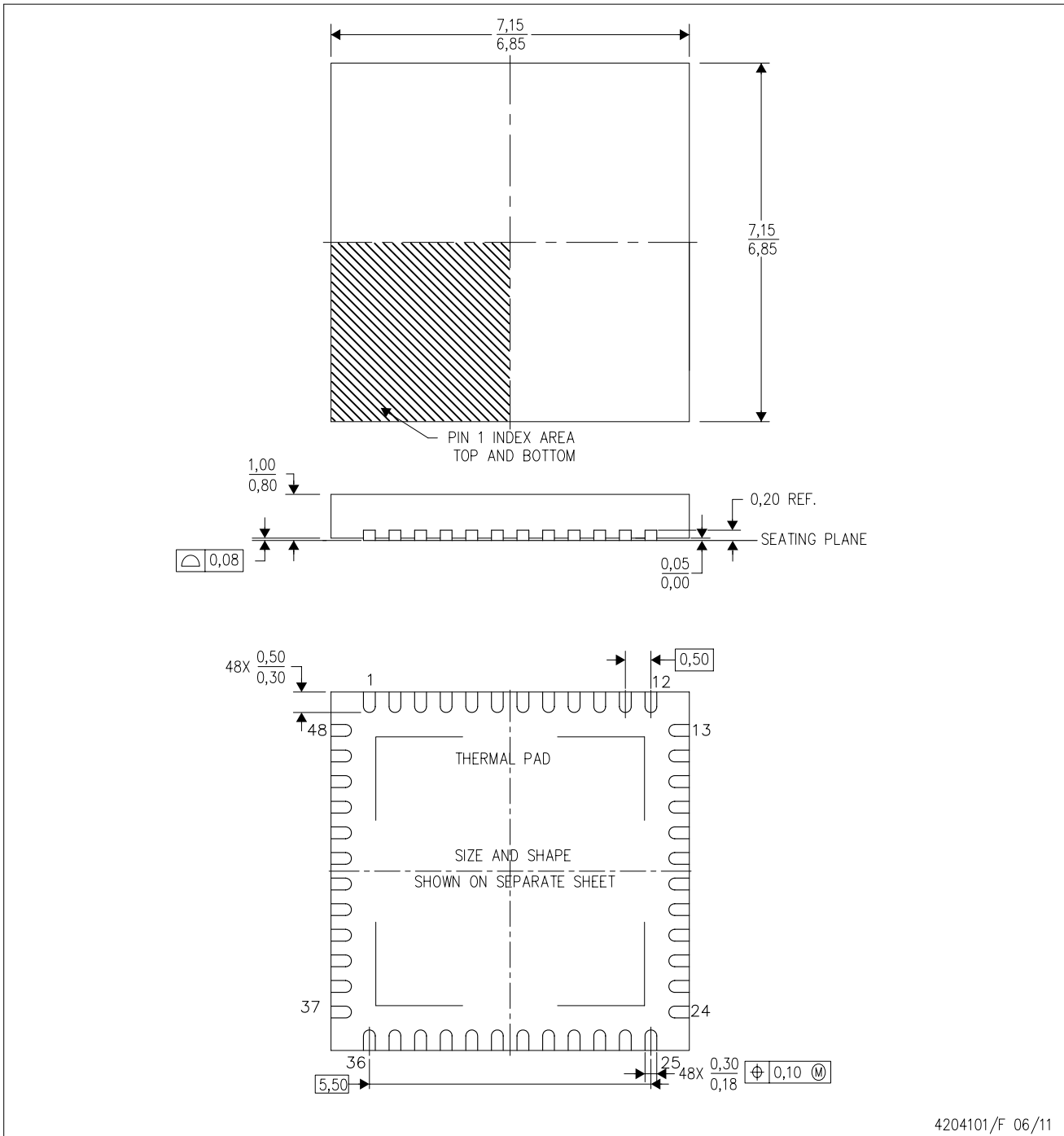

- NOTES:
- A. All linear dimensions are in millimeters. Dimensioning and tolerancing per ASME Y14.5M-1994.
 - B. This drawing is subject to change without notice.
 - C. Quad Flatpack, No-leads (QFN) package configuration.
 - D. The package thermal pad must be soldered to the board for thermal and mechanical performance.
 - E. See the additional figure in the Product Data Sheet for details regarding the exposed thermal pad features and dimensions.
 - F. Falls within JEDEC MO-220.

THERMAL PAD MECHANICAL DATA

RGZ (S-PVQFN-N48)

PLASTIC QUAD FLATPACK NO-LEAD

THERMAL INFORMATION

This package incorporates an exposed thermal pad that is designed to be attached directly to an external heatsink. The thermal pad must be soldered directly to the printed circuit board (PCB). After soldering, the PCB can be used as a heatsink. In addition, through the use of thermal vias, the thermal pad can be attached directly to the appropriate copper plane shown in the electrical schematic for the device, or alternatively, can be attached to a special heatsink structure designed into the PCB. This design optimizes the heat transfer from the integrated circuit (IC).

For information on the Quad Flatpack No-Lead (QFN) package and its advantages, refer to Application Report, QFN/SON PCB Attachment, Texas Instruments Literature No. SLUA271. This document is available at www.ti.com.

The exposed thermal pad dimensions for this package are shown in the following illustration.

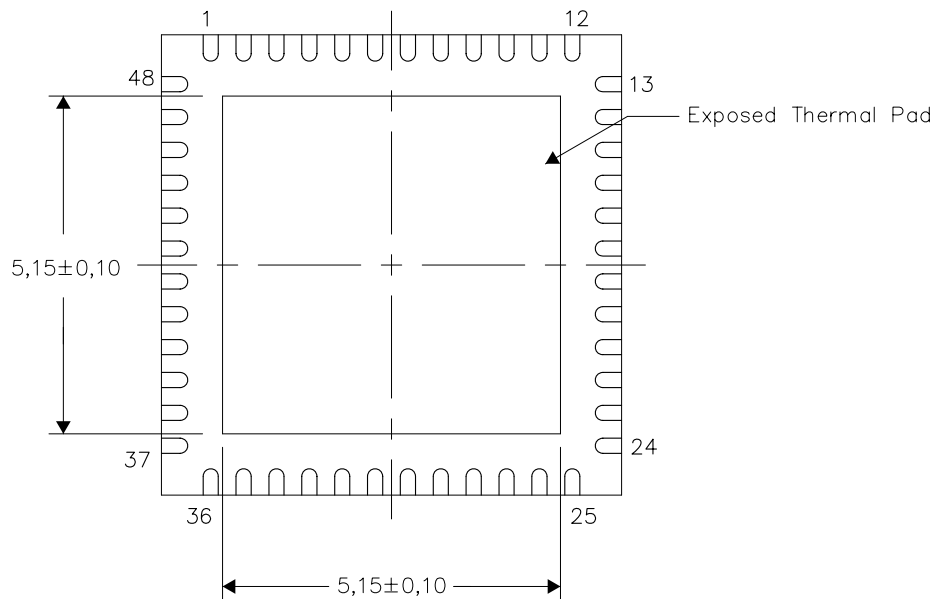

4206354-2/R 08/11

NOTE: All linear dimensions are in millimeters

IMPORTANT NOTICE

Texas Instruments Incorporated and its subsidiaries (TI) reserve the right to make corrections, modifications, enhancements, improvements, and other changes to its products and services at any time and to discontinue any product or service without notice. Customers should obtain the latest relevant information before placing orders and should verify that such information is current and complete. All products are sold subject to TI's terms and conditions of sale supplied at the time of order acknowledgment.

TI warrants performance of its hardware products to the specifications applicable at the time of sale in accordance with TI's standard warranty. Testing and other quality control techniques are used to the extent TI deems necessary to support this warranty. Except where mandated by government requirements, testing of all parameters of each product is not necessarily performed.

TI assumes no liability for applications assistance or customer product design. Customers are responsible for their products and applications using TI components. To minimize the risks associated with customer products and applications, customers should provide adequate design and operating safeguards.

TI does not warrant or represent that any license, either express or implied, is granted under any TI patent right, copyright, mask work right, or other TI intellectual property right relating to any combination, machine, or process in which TI products or services are used. Information published by TI regarding third-party products or services does not constitute a license from TI to use such products or services or a warranty or endorsement thereof. Use of such information may require a license from a third party under the patents or other intellectual property of the third party, or a license from TI under the patents or other intellectual property of TI.

Reproduction of TI information in TI data books or data sheets is permissible only if reproduction is without alteration and is accompanied by all associated warranties, conditions, limitations, and notices. Reproduction of this information with alteration is an unfair and deceptive business practice. TI is not responsible or liable for such altered documentation. Information of third parties may be subject to additional restrictions.

Resale of TI products or services with statements different from or beyond the parameters stated by TI for that product or service voids all express and any implied warranties for the associated TI product or service and is an unfair and deceptive business practice. TI is not responsible or liable for any such statements.

TI products are not authorized for use in safety-critical applications (such as life support) where a failure of the TI product would reasonably be expected to cause severe personal injury or death, unless officers of the parties have executed an agreement specifically governing such use. Buyers represent that they have all necessary expertise in the safety and regulatory ramifications of their applications, and acknowledge and agree that they are solely responsible for all legal, regulatory and safety-related requirements concerning their products and any use of TI products in such safety-critical applications, notwithstanding any applications-related information or support that may be provided by TI. Further, Buyers must fully indemnify TI and its representatives against any damages arising out of the use of TI products in such safety-critical applications.

TI products are neither designed nor intended for use in military/aerospace applications or environments unless the TI products are specifically designated by TI as military-grade or "enhanced plastic." Only products designated by TI as military-grade meet military specifications. Buyers acknowledge and agree that any such use of TI products which TI has not designated as military-grade is solely at the Buyer's risk, and that they are solely responsible for compliance with all legal and regulatory requirements in connection with such use.

TI products are neither designed nor intended for use in automotive applications or environments unless the specific TI products are designated by TI as compliant with ISO/TS 16949 requirements. Buyers acknowledge and agree that, if they use any non-designated products in automotive applications, TI will not be responsible for any failure to meet such requirements.

Following are URLs where you can obtain information on other Texas Instruments products and application solutions:

Products

Audio	www.ti.com/audio
Amplifiers	amplifier.ti.com
Data Converters	dataconverter.ti.com
DLP® Products	www.dlp.com
DSP	dsp.ti.com
Clocks and Timers	www.ti.com/clocks
Interface	interface.ti.com
Logic	logic.ti.com
Power Mgmt	power.ti.com
Microcontrollers	microcontroller.ti.com
RFID	www.ti-rfid.com
OMAP Mobile Processors	www.ti.com/omap
Wireless Connectivity	www.ti.com/wirelessconnectivity

Applications

Automotive and Transportation	www.ti.com/automotive
Communications and Telecom	www.ti.com/communications
Computers and Peripherals	www.ti.com/computers
Consumer Electronics	www.ti.com/consumer-apps
Energy and Lighting	www.ti.com/energy
Industrial	www.ti.com/industrial
Medical	www.ti.com/medical
Security	www.ti.com/security
Space, Avionics and Defense	www.ti.com/space-avionics-defense
Video and Imaging	www.ti.com/video

TI E2E Community Home Page

e2e.ti.com

Mailing Address: Texas Instruments, Post Office Box 655303, Dallas, Texas 75265
Copyright © 2012, Texas Instruments Incorporated