

High Power Factor Preregulator

FEATURES

- Complete 8-pin Power Factor Solution
- Reduced External Components
- RMS Line Voltage Compensation
- Precision Multiplier/Squarer/Divider
- Internal 75kHz Synchronizable Oscillator
- Average Current Mode PWM Control
- Overvoltage Protection Comparator
- High Current, Clamped Gate Driver

DESCRIPTION

The UC3853 provides simple, yet high performance active power factor correction. Using the same control technique as the UC1854, this 8-pin device exploits a simplified architecture and an internal oscillator to minimize external component count. The UC3853 incorporates a precision multiplier/squarer/divider circuit, voltage and current loop error amplifiers, and a precision voltage reference to implement average current mode control with RMS line voltage compensation. This control technique maintains constant loop gain with changes in input voltage, which minimizes input line current distortion over the worldwide input voltage range.

The internal 75kHz oscillator includes an external clock input, allowing synchronization to downstream converters. Additionally, the device features an overvoltage protection comparator, a clamped MOSFET gate driver which self-biases low during undervoltage lockout, and low startup and supply current.

These devices are available in 8-pin plastic and ceramic dual in-line (DIP) packages, and 8-lead small outline (SOIC) packages. The UC1853 is specified for operation from -55°C to $+125^{\circ}\text{C}$, the UC2853 is specified for operation from -25°C to $+85^{\circ}\text{C}$, and the UC3853 is specified for operation from 0°C to $+70^{\circ}\text{C}$.

BLOCK DIAGRAM

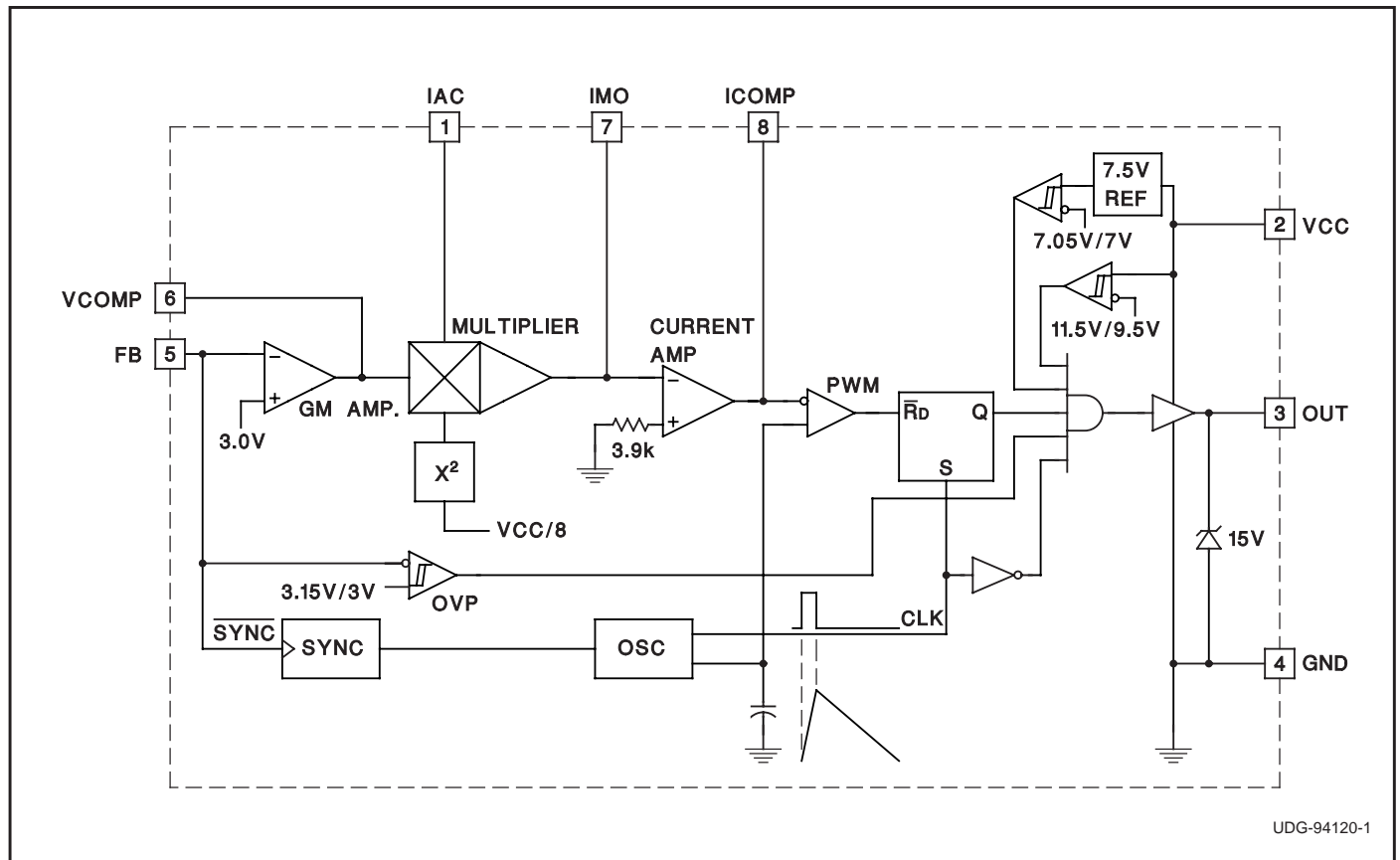

ABSOLUTE MAXIMUM RATINGS

| | |
|---|-----------------|
| Supply Voltage (VCC) | 40V |
| Output Drive Current, | |
| Continuous | 0.125A |
| Peak | 0.5A |
| Output Minimum Voltage | -0.3V |
| IAC Maximum Input Current | 1mA |
| IMO Maximum Output Current | -2mA |
| IMO Minimum Voltage | -0.3V |
| FB Maximum Input Voltage | 5V |
| VCOMP Maximum Voltage | 6.2V |
| ICOMP Sourcing Current | Self-Limiting |
| ICOMP Sinking Current | 20mA |
| ICOMP Maximum Voltage | 7.2V |
| Storage Temperature | -65°C to +150°C |
| Junction Temperature | -55°C to +150°C |
| Lead Temperature (Soldering, 10 sec.) | +300°C |

All voltages with respect to GND. Currents are positive into, negative out of the specified terminal. Consult Packaging Section of Databook for thermal limitations and considerations of packages.

CONNECTION DIAGRAM

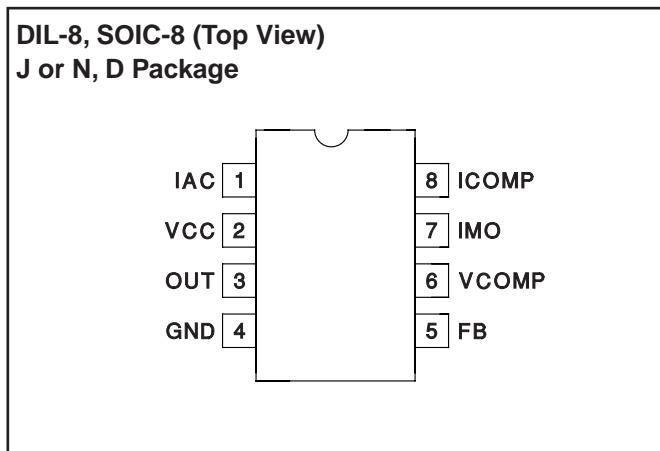

ELECTRICAL CHARACTERISTICS

Unless otherwise stated, these parameters apply for $T_A = -55^\circ\text{C}$ to $+125^\circ\text{C}$ for the UC1853; -25°C to $+85^\circ\text{C}$ for the 2853; and 0°C to $+70^\circ\text{C}$ for the UC3853; $V_{CC} = 16\text{V}$, $V_{FB} = 3\text{V}$, $I_{AC} = 100\mu\text{A}$, $V_{VCOMP} = 3.75\text{V}$, $V_{ICOMP} = 3\text{V}$, $T_A = T_J$.

| PARAMETER | TEST CONDITIONS | MIN | TYP | MAX | UNITS |
|---|---|-------|------|-------|-----------------|
| Undervoltage Lockout Section | | | | | |
| VCC Turn-on Threshold | V_{VCOMP} , V_{ICOMP} Open | | 11.5 | 13 | V |
| Hysteresis | | 1.5 | 1.8 | 2.1 | V |
| Supply Current Section | | | | | |
| I_{VCC} Startup | $V_{CC} = 8\text{V}$, $I_{AC} = 100\mu\text{A}$; V_{VCOMP} , V_{ICOMP} Open | | 250 | 500 | μA |
| I_{VCC} | $I_{AC} = 0\mu\text{A}$, $V_{ICOMP} = 0\text{V}$ | | 10 | 15 | mA |
| Voltage Loop Error Amplifier Section | | | | | |
| Transconductance | $I_{OUT} = \pm 20\mu\text{A}$ 0-70C | 300 | 450 | 575 | μmho |
| | Temperature | 135 | | 640 | μmho |
| Input Voltage | 0-70C | 2.925 | 3 | 3.075 | V |
| | Temperature | 2.9 | | 3.1 | V |
| AVOL | $V_{VCOMP} = 1\text{V} - 4\text{V}$ | 50 | 60 | | dB |
| Output Sink Current | $V_{FB} = 3.2\text{V}$, $V_{VCOMP} = 3.75\text{V}$ | 20 | 50 | | μA |
| Output Source Current | $V_{FB} = 2.8\text{V}$, $V_{VCOMP} = 3.75\text{V}$ | | -50 | -20 | μA |
| Output Voltage High | | 5.5 | 6 | | V |
| Output Voltage Low | | | 0.6 | 0.9 | V |
| Current Loop Error Amplifier Section | | | | | |
| Offset Voltage | | 0 | | 6 | mV |
| Voltage Gain | $V_{ICOMP} = 1\text{V} - 4\text{V}$ | | 70 | | dB |
| Sink Current | $V_{IMO} = 100\text{mV}$, $V_{ICOMP} = 3\text{V}$ | 1 | | | mA |
| Source Current | $V_{IMO} = -0.1\text{V}$, $V_{ICOMP} = 3\text{V}$ | | -150 | -80 | μA |
| Output High | $I_{ICOMP} = -50\text{mA}$ | 6 | 6.8 | | V |
| Output Low | $I_{ICOMP} = 50\mu\text{A}$ | | 0.3 | 0.8 | V |
| PWM Modulator Gain | $V_{ICOMP} = 2\text{V} - 3\text{V}$ (Note 1) | | 20 | | %/V |

ELECTRICAL CHARACTERISTICS
(continued)

Unless otherwise stated, these parameters apply for $T_A = -55^\circ\text{C}$ to $+125^\circ\text{C}$ for the UC1853; -25°C to $+85^\circ\text{C}$ for the 2853; and 0°C to $+70^\circ\text{C}$ for the UC3853; $V_{CC} = 16\text{V}$, $V_{FB} = 3\text{V}$, $I_{AC} = 100\mu\text{A}$, $V_{VCOMP} = 3.75\text{V}$, $V_{ICOMP} = 3\text{V}$, $T_A = T_J$.

| PARAMETER | TEST CONDITIONS | MIN | TYP | MAX | UNITS |
|---------------------------------|--|-------|------|-------|-----------------|
| Multiplier Section | | | | | |
| Output Current – IAC Limited | $V_{CC} = 11\text{V}$, $V_{VCOMP} = 6\text{V}$ | -230 | -200 | -170 | μA |
| Output Current – Zero | $I_{AC} = 0\mu\text{A}$ | -2 | -0.2 | 2 | μA |
| Output Current – Power Limited | $V_{CC} = 12\text{V}$, $V_{VCOMP} = 5.5\text{V}$ | -236 | -178 | -168 | μA |
| Output Current | $V_{CC} = 12\text{V}$, $V_{VCOMP} = 2\text{V}$ | | -22 | | μA |
| | $V_{CC} = 12\text{V}$, $V_{VCOMP} = 5\text{V}$ | | -156 | | μA |
| | $V_{CC} = 40\text{V}$, $V_{VCOMP} = 2\text{V}$ | | -2 | | μA |
| | $V_{CC} = 40\text{V}$, $V_{VCOMP} = 5\text{V}$ | | -14 | | μA |
| Multiplier Gain Constant | $V_{CC} = 12\text{V}$, $V_{VCOMP} = 5.5\text{V}$ (Note 2) | -1.05 | -0.9 | -0.75 | V^{-1} |
| Oscillator Section | | | | | |
| Oscillator Initial Frequency | $T_A = 25^\circ\text{C}$ | 67.5 | 75 | 82.5 | kHz |
| Oscillator Frequency | Line, Load, Temperature | 56 | 75 | 94 | kHz |
| Synchronization Frequency Range | | | | 100 | kHz |
| Synchronization Pulse Amplitude | Pulse slew rate = $100\text{V}/\mu\text{sec}$ (Note 3) | | 2 | | V |
| Output Driver Section | | | | | |
| Maximum Output Voltage | 0mA load, $V_{CC} = 20\text{V}$ | 12 | 15 | 17.5 | V |
| Output High | 0mA load, $V_{CC} = 12\text{V}$, ref. to V_{CC} | -2.7 | -1.7 | | V |
| | -50mA load, $V_{CC} = 12\text{V}$, ref. to V_{CC} | -3 | -2.2 | | V |
| Output Low (Device Inactive) | $V_{CC} = 0\text{V}$, 20mA load (Sinking) | | 0.9 | 2.0 | V |
| Output Low (Device Active) | 50mA load (Sinking) | | 0.5 | 1 | V |
| OUT Rise Time | 1nF from OUT to GND | | 55 | 100 | ns |
| OUT Fall Time | 1nF from OUT to GND | | 35 | 100 | ns |
| OUT Maximum Duty Cycle | $V_{ICOMP} = 0\text{V}$ | 88 | 93 | | % |
| OVP Comparator Section | | | | | |
| Threshold Voltage | Volts Above EA Input V | 90 | 150 | | mV |
| Hysteresis | | | 80 | | mV |

Note 1:

$$PWM \text{ modulator gain} = \frac{\Delta DutyCycle}{\Delta V_{ICOMP}}$$

Note 2:

$$Gain \text{ constant } (K) = \frac{I_{AC} \cdot (V_{COMP} - 1.5\text{V})}{I_{MO} \cdot V_{CC} \cdot \frac{V_{CC}}{64}}, \quad V_{CC} = 12\text{V}.$$

Note 3:

Synchronization is accomplished with a falling edge of 2V magnitude and $100\text{V}/\mu\text{sec}$ slew rate.

PIN DESCRIPTIONS

FB: Voltage Amplifier Inverting Input, Overvoltage Comparator Input, Sync Input. This pin serves three functions. FB accepts a fraction of the power factor corrected output voltage through a voltage divider, and is nominally regulated to 3V. FB voltages 5% greater than nominal will trip the overvoltage comparator, and shut down the output stage until the output voltage drops 5%. The internal oscillator can be synchronized through FB by injecting a 2V clock signal through a capacitor. To prevent false tripping of the overvoltage comparator, the clock signal must have a fast falling edge, but a slow rising edge. See Application Note U-159 for more information.

GND: Ground. All voltages are measured with respect to GND. The VCC bypass capacitor should be connected to ground as close to the GND pin as possible.

IAC: AC Waveform Input. This input provides voltage waveform information to the multiplier. The current loop will try to produce a current waveform with the same shape as the IAC signal. IAC is a low impedance input, nominally at 2V, which accepts a current proportional to the input voltage. Connect a resistor from the rectified input line to IAC which will conduct 500mA at maximum line voltage.

IMO: Multiplier Output and Current Sense Inverting Input. The output of the multiplier and the inverting input of the current amplifier are connected together at IMO. Avoid bringing this input below -0.5V to prevent the internal protection diode from conducting. The multiplier output is a current, making this a summing node and allowing a differential current error amplifier configuration to reject ground noise. The input resistance at this node should be 3.9k to minimize input bias current induced offset voltage. See the Applications section for the recommended circuit configuration.

OUT: Gate Driver Output. OUT provides high current gate drive for the external power MOSFET. A 15V clamp pre-

vents excessive MOSFET gate-to-source voltage so that the UC3853 can be operated with VCC and high as 40V. A series gate resistor of at least 5 ohms should be used to minimize clamp voltage overshoot. In addition, a Schottky diode such as a 1N5818 connected between OUT and GND may be necessary to prevent parasitic substrate diode conduction.

ICOMP: Current Loop Error Amplifier Output. The current loop error amplifier is a conventional operational amplifier with a 150μA current source class A output stage. Compensate the current loop by placing an impedance between ICOMP and IMO. This output can swing above the oscillator peak voltage, allowing zero duty cycle when necessary.

VCC: Input Supply Voltage. This pin serves two functions. It supplies power to the chip, and an input voltage level signal to the squarer circuit. When this input is connected to a DC voltage proportional to the AC input RMS voltage, the voltage loop gain is reduced by

$$\frac{64}{V_{CC}^2}$$

This configuration maintains constant loop gain. The UC3853 input voltage range extends from 12V to 40V, allowing an AC supply voltage range in excess of 85VAC to 265VAC. Bypass VCC with at least a 0.1μF ceramic capacitor to ensure proper operation. See the Applications section for the recommended circuit configuration.

VCOMP: Voltage Loop Error Amplifier Output. The voltage loop error amplifier is a transconductance type operational amplifier. A feedback impedance between VCOMP and FB for loop compensation must be avoided to maintain proper operation of the overvoltage protection comparator. Instead, compensate the voltage loop with an impedance between VCOMP and GND. When VCOMP is below 1.5V, the multiplier output current is zero.

UC3853 TYPICAL APPLICATION

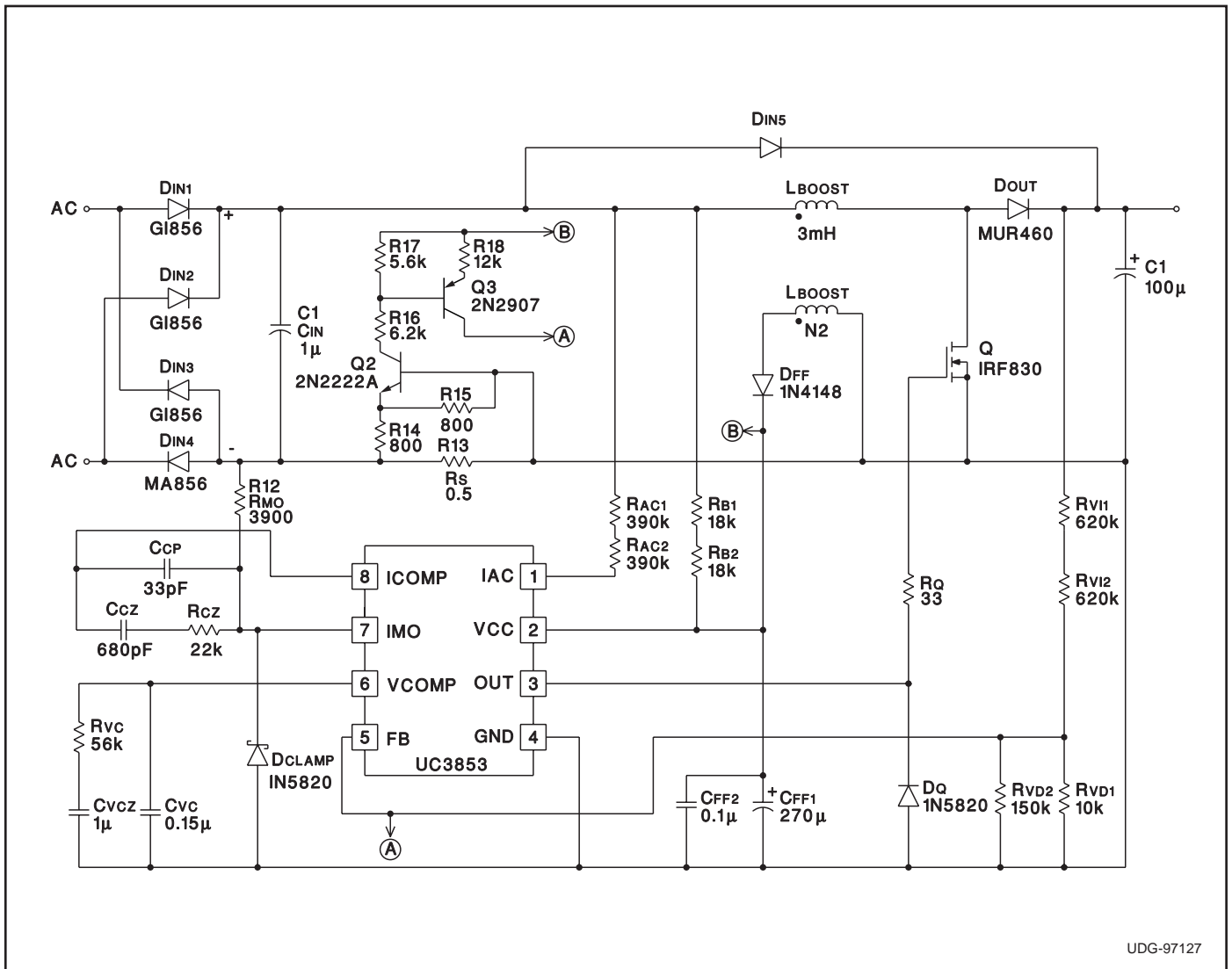

Note: the application circuit shown is a 100W, 75KHz design.
Additional application information can be found in Application
Note U-159 and Design Note DN-78.

PACKAGING INFORMATION

| Orderable Device | Status ⁽¹⁾ | Package Type | Package Drawing | Pins | Package Qty | Eco Plan ⁽²⁾ | Lead/Ball Finish | MSL Peak Temp ⁽³⁾ |
|------------------|-----------------------|--------------|-----------------|------|-------------|-------------------------|------------------|------------------------------|
| UC2853D | ACTIVE | SOIC | D | 8 | 75 | Green (RoHS & no Sb/Br) | CU NIPDAU | Level-2-260C-1 YEAR |
| UC2853DG4 | ACTIVE | SOIC | D | 8 | 75 | Green (RoHS & no Sb/Br) | CU NIPDAU | Level-2-260C-1 YEAR |
| UC2853DTR | ACTIVE | SOIC | D | 8 | 2500 | Green (RoHS & no Sb/Br) | CU NIPDAU | Level-2-260C-1 YEAR |
| UC2853DTRG4 | ACTIVE | SOIC | D | 8 | 2500 | Green (RoHS & no Sb/Br) | CU NIPDAU | Level-2-260C-1 YEAR |
| UC2853N | ACTIVE | PDIP | P | 8 | 50 | Green (RoHS & no Sb/Br) | CU NIPDAU | N / A for Pkg Type |
| UC2853NG4 | ACTIVE | PDIP | P | 8 | 50 | Green (RoHS & no Sb/Br) | CU NIPDAU | N / A for Pkg Type |
| UC3853D | ACTIVE | SOIC | D | 8 | 75 | Green (RoHS & no Sb/Br) | CU NIPDAU | Level-2-260C-1 YEAR |
| UC3853DG4 | ACTIVE | SOIC | D | 8 | 75 | Green (RoHS & no Sb/Br) | CU NIPDAU | Level-2-260C-1 YEAR |
| UC3853DTR | ACTIVE | SOIC | D | 8 | 2500 | Green (RoHS & no Sb/Br) | CU NIPDAU | Level-2-260C-1 YEAR |
| UC3853DTRG4 | ACTIVE | SOIC | D | 8 | 2500 | Green (RoHS & no Sb/Br) | CU NIPDAU | Level-2-260C-1 YEAR |
| UC3853N | ACTIVE | PDIP | P | 8 | 50 | Green (RoHS & no Sb/Br) | CU NIPDAU | N / A for Pkg Type |
| UC3853NG4 | ACTIVE | PDIP | P | 8 | 50 | Green (RoHS & no Sb/Br) | CU NIPDAU | N / A for Pkg Type |

⁽¹⁾ The marketing status values are defined as follows:

ACTIVE: Product device recommended for new designs.

LIFEBUY: TI has announced that the device will be discontinued, and a lifetime-buy period is in effect.

NRND: Not recommended for new designs. Device is in production to support existing customers, but TI does not recommend using this part in a new design.

PREVIEW: Device has been announced but is not in production. Samples may or may not be available.

OBSOLETE: TI has discontinued the production of the device.

⁽²⁾ Eco Plan - The planned eco-friendly classification: Pb-Free (RoHS), Pb-Free (RoHS Exempt), or Green (RoHS & no Sb/Br) - please check <http://www.ti.com/productcontent> for the latest availability information and additional product content details.

TBD: The Pb-Free/Green conversion plan has not been defined.

Pb-Free (RoHS): TI's terms "Lead-Free" or "Pb-Free" mean semiconductor products that are compatible with the current RoHS requirements for all 6 substances, including the requirement that lead not exceed 0.1% by weight in homogeneous materials. Where designed to be soldered at high temperatures, TI Pb-Free products are suitable for use in specified lead-free processes.

Pb-Free (RoHS Exempt): This component has a RoHS exemption for either 1) lead-based flip-chip solder bumps used between the die and package, or 2) lead-based die adhesive used between the die and leadframe. The component is otherwise considered Pb-Free (RoHS compatible) as defined above.

Green (RoHS & no Sb/Br): TI defines "Green" to mean Pb-Free (RoHS compatible), and free of Bromine (Br) and Antimony (Sb) based flame retardants (Br or Sb do not exceed 0.1% by weight in homogeneous material)

⁽³⁾ MSL, Peak Temp. -- The Moisture Sensitivity Level rating according to the JEDEC industry standard classifications, and peak solder temperature.

Important Information and Disclaimer: The information provided on this page represents TI's knowledge and belief as of the date that it is provided. TI bases its knowledge and belief on information provided by third parties, and makes no representation or warranty as to the accuracy of such information. Efforts are underway to better integrate information from third parties. TI has taken and continues to take reasonable steps to provide representative and accurate information but may not have conducted destructive testing or chemical analysis on incoming materials and chemicals. TI and TI suppliers consider certain information to be proprietary, and thus CAS numbers and other limited information may not be available for release.

In no event shall TI's liability arising out of such information exceed the total purchase price of the TI part(s) at issue in this document sold by TI to Customer on an annual basis.

TAPE AND REEL INFORMATION



QUADRANT ASSIGNMENTS FOR PIN 1 ORIENTATION IN TAPE



*All dimensions are nominal

| Device | Package Type | Package Drawing | Pins | SPQ | Reel Diameter (mm) | Reel Width W1 (mm) | A0 (mm) | B0 (mm) | K0 (mm) | P1 (mm) | W (mm) | Pin1 Quadrant |
|-----------|--------------|-----------------|------|------|--------------------|--------------------|---------|---------|---------|---------|--------|---------------|
| UC2853DTR | SOIC | D | 8 | 2500 | 330.0 | 12.4 | 6.4 | 5.2 | 2.1 | 8.0 | 12.0 | Q1 |
| UC3853DTR | SOIC | D | 8 | 2500 | 330.0 | 12.4 | 6.4 | 5.2 | 2.1 | 8.0 | 12.0 | Q1 |

TAPE AND REEL BOX DIMENSIONS



*All dimensions are nominal

| Device | Package Type | Package Drawing | Pins | SPQ | Length (mm) | Width (mm) | Height (mm) |
|-----------|--------------|-----------------|------|------|-------------|------------|-------------|
| UC2853DTR | SOIC | D | 8 | 2500 | 346.0 | 346.0 | 29.0 |
| UC3853DTR | SOIC | D | 8 | 2500 | 346.0 | 346.0 | 29.0 |

IMPORTANT NOTICE

Texas Instruments Incorporated and its subsidiaries (TI) reserve the right to make corrections, modifications, enhancements, improvements, and other changes to its products and services at any time and to discontinue any product or service without notice. Customers should obtain the latest relevant information before placing orders and should verify that such information is current and complete. All products are sold subject to TI's terms and conditions of sale supplied at the time of order acknowledgment.

TI warrants performance of its hardware products to the specifications applicable at the time of sale in accordance with TI's standard warranty. Testing and other quality control techniques are used to the extent TI deems necessary to support this warranty. Except where mandated by government requirements, testing of all parameters of each product is not necessarily performed.

TI assumes no liability for applications assistance or customer product design. Customers are responsible for their products and applications using TI components. To minimize the risks associated with customer products and applications, customers should provide adequate design and operating safeguards.

TI does not warrant or represent that any license, either express or implied, is granted under any TI patent right, copyright, mask work right, or other TI intellectual property right relating to any combination, machine, or process in which TI products or services are used. Information published by TI regarding third-party products or services does not constitute a license from TI to use such products or services or a warranty or endorsement thereof. Use of such information may require a license from a third party under the patents or other intellectual property of the third party, or a license from TI under the patents or other intellectual property of TI.

Reproduction of TI information in TI data books or data sheets is permissible only if reproduction is without alteration and is accompanied by all associated warranties, conditions, limitations, and notices. Reproduction of this information with alteration is an unfair and deceptive business practice. TI is not responsible or liable for such altered documentation. Information of third parties may be subject to additional restrictions.

Resale of TI products or services with statements different from or beyond the parameters stated by TI for that product or service voids all express and any implied warranties for the associated TI product or service and is an unfair and deceptive business practice. TI is not responsible or liable for any such statements.

TI products are not authorized for use in safety-critical applications (such as life support) where a failure of the TI product would reasonably be expected to cause severe personal injury or death, unless officers of the parties have executed an agreement specifically governing such use. Buyers represent that they have all necessary expertise in the safety and regulatory ramifications of their applications, and acknowledge and agree that they are solely responsible for all legal, regulatory and safety-related requirements concerning their products and any use of TI products in such safety-critical applications, notwithstanding any applications-related information or support that may be provided by TI. Further, Buyers must fully indemnify TI and its representatives against any damages arising out of the use of TI products in such safety-critical applications.

TI products are neither designed nor intended for use in military/aerospace applications or environments unless the TI products are specifically designated by TI as military-grade or "enhanced plastic." Only products designated by TI as military-grade meet military specifications. Buyers acknowledge and agree that any such use of TI products which TI has not designated as military-grade is solely at the Buyer's risk, and that they are solely responsible for compliance with all legal and regulatory requirements in connection with such use.

TI products are neither designed nor intended for use in automotive applications or environments unless the specific TI products are designated by TI as compliant with ISO/TS 16949 requirements. Buyers acknowledge and agree that, if they use any non-designated products in automotive applications, TI will not be responsible for any failure to meet such requirements.

Following are URLs where you can obtain information on other Texas Instruments products and application solutions:

Products

| | |
|-----------------------------|--|
| Amplifiers | amplifier.ti.com |
| Data Converters | dataconverter.ti.com |
| DSP | dsp.ti.com |
| Clocks and Timers | www.ti.com/clocks |
| Interface | interface.ti.com |
| Logic | logic.ti.com |
| Power Mgmt | power.ti.com |
| Microcontrollers | microcontroller.ti.com |
| RFID | www.ti-rfid.com |
| RF/IF and ZigBee® Solutions | www.ti.com/lprf |

Applications

| | |
|--------------------|--|
| Audio | www.ti.com/audio |
| Automotive | www.ti.com/automotive |
| Broadband | www.ti.com/broadband |
| Digital Control | www.ti.com/digitalcontrol |
| Medical | www.ti.com/medical |
| Military | www.ti.com/military |
| Optical Networking | www.ti.com/opticalnetwork |
| Security | www.ti.com/security |
| Telephony | www.ti.com/telephony |
| Video & Imaging | www.ti.com/video |
| Wireless | www.ti.com/wireless |

Mailing Address: Texas Instruments, Post Office Box 655303, Dallas, Texas 75265
Copyright © 2008, Texas Instruments Incorporated