

Precision Analog Controller

FEATURES

- Programmable Transconductance for Optimum Current Drive
- Accessible 1.3V Precision Reference
- Both Error Amplifier Inputs Available
- 0.7% Overall Reference Tolerance
- 0.4% Initial Accuracy
- 2.2V to 24.0V Operating Supply Voltage and User Programmable Reference
- Reference Accuracy Maintained for Entire Range of Supply Voltage
- Superior Accuracy and Easier Compensation for Optoisolator Application
- Low Quiescent Current (0.50mA Typ)

DESCRIPTION

The UC39432 is an adjustable precision analog controller with 100mA sink capability if the ISET pin is grounded. A resistor between ISET and ground will modify the transconductance while decreasing the maximum current sink. This will add further control in the optocoupler configuration. The trimmed precision reference along with the non-inverting error amplifier inputs are accessible for custom configuration. A sister device, the UC39431 adjustable shunt regulator, has an on-board resistor network providing six preprogrammed voltage levels, as well as external programming capability.

BLOCK DIAGRAM

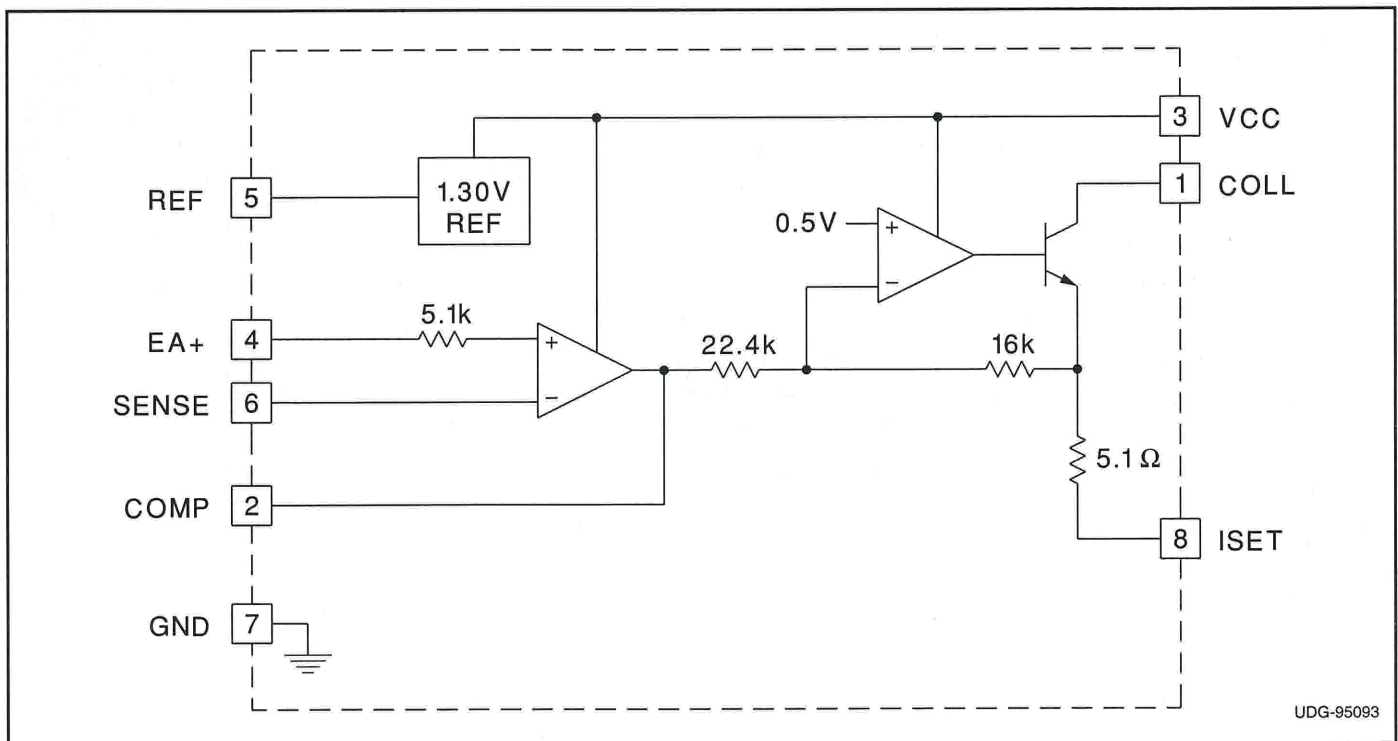

CONNECTION DIAGRAM

ABSOLUTE MAXIMUM RATINGS

Supply Voltage: VCC	24V
Regulated Output: V _{COLL}	24V
EA Input: SENSE, EA+	6V
EA Compensation: COMP	6V
Reference Output: REF	6V
Output Sink Current: I _{COLL}	140mA
Output Source Current: ISET	-140mA
Power Dissipation at T _A ≤ 25°C (DIL-8)	1W
Derate 8mW/°C for T _A > 25°C	
Storage Temperature Range	-65°C to +150°C
Junction Temperature	-55°C to +150°C
Lead Temperature (Soldering, 10 sec.)	+300°C

Currents are positive into, negative out of the specified terminal. Consult Packaging Section of Databook for thermal limitations and considerations of packages.

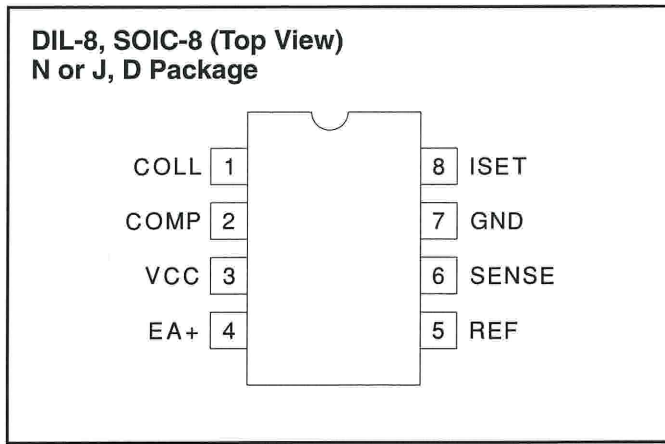

ELECTRICAL CHARACTERISTICS: Unless otherwise stated, these specifications apply for T_A = -55°C to +125°C and COLL Output = 2.4V to 24.0V for the UC19432, T_A = -25°C to +85°C and COLL Output = 2.3V to 24.0V for the UC29432, and T_A = 0°C to +70°C and COLL Output = 2.3V to 24.0V for the UC39432, VCC = 15V, I_{COLL} = 10mA, T_A = T_J.

PARAMETER	TEST CONDITIONS		MIN	TYP	MAX	UNITS
Reference Voltage Tolerance	T _A = 25°C	19432*	1.295	1.3	1.305	V
		39432B	1.29	1.3	1.31	V
Reference Temperature Tolerance	V _{COLL} = 5.0V	19432*	1.291	1.3	1.309	V
		39432B	1.286	1.3	1.314	V
Reference Line Regulation	VCC = 2.4V to 24.0V, V _{COLL} = 5V	19432*		10	38	mV
		39432B		10	57	mV
Reference Load Regulation	I _{COLL} = 10mA to 50mA, V _{COLL} = 5V	19432*		10	38	mV
		39432B		10	57	mV
Reference Sink Current					10	μA
Reference Source Current					-10	μA
EA Input Bias Current			-0.5	-0.2		μA
EA Input Offset Voltage		19432*			4.0	mV
		39432B			4.0	mV
EA+ Operational Voltage Limitations	(Note 1)		0.9		1.6	V
EA Output Current Sink (Internally Limited)					16	μA
EA Output Current Source					-1	mA
Minimum Operating Current	VCC = 24.0V, V _{COLL} = 5V			0.50	0.80	mA
Collector Current Limit (Note)	V _{COLL} = VCC = 24.0V, Ref = 1.35V ISET = GND			130	145	mA
Collector Saturation	I _{COLL} = 20mA		0.7	1.1	1.5	V
Transconductance (gm) (Note)	VCC = 2.4V to 24.0V, V _{COL} = 3V, I _{COLL} = 20mA ISET = GND	19432*	-170	-140	-110	mS
		39432B	-180	-140	-100	mS
Error Amplifier AVOL			60	90		dB
Error Amplifier GBW	(Note 1)		3.0	5		MHz
Transconductance Amplifier GBW				3		MHz

* Also applies to the UC29432 and UC39432

Note: Programmed transconductance and collector current limit equations are specified in the ISET pin description.

Note 1: Guaranteed by design. Not 100% tested in production.

PIN DESCRIPTIONS

COLL: The collector of the output transistor with a maximum voltage of 24V. This pin is the output of the transconductance amplifier. The overall open loop voltage gain of the transconductance amplifier is $g_m \cdot R_L$, where g_m is designed to be $-140\text{mS} \pm 30\text{mS}$ and R_L represents the output load.

COMP: The output of the error amplifier and the input to the transconductance amplifier. This pin is available to compensate the high frequency gain of the error amplifier. It is internally voltage limited to approximately 2.0V.

EA+: The non-inverting input to the error amplifier.

GND: The reference and power ground for the device. The power ground of the output transistor is isolated on the chip from the substrate ground used to bias the remainder of the device.

ISET: The current set pin for the transconductance amplifier. The transconductance will be -140mS as specified in the electrical table if this pin is grounded. If a resistance R_L is added to the ISET pin, the resulting new transconductance is calculated using the following equation: $g_m = -0.714\text{V} \cdot (5.1\Omega + R_L)$. The maximum current will be approximately

$$I_{MAX} = \frac{0.6\text{V}}{5.1\Omega + R_L}$$

REF: The output of the trimmed precision reference. It can source or sink $10\mu\text{A}$ and still maintain the 1% temperature specification.

SENSE: The inverting terminal of the error amplifier used as both the voltage sense input to the error amplifier and its other compensation point. The error amplifier uses the SENSE input to compare against the 1.3V on-chip reference.

The SENSE pin is also used as the undervoltage lockout (UVLO). It is intended to keep the chip from operating until the internal reference is properly biased. The threshold is approximately 1V. It is important that once the UVLO is released, the error amplifier can drive the transconductance amplifier to stabilize the loop. If a capacitor is connected between the SENSE and COMP pins to create a pole, it will limit the slew rate of the error amplifier. To increase the bandwidth and ensure startup at low load current, it is recommended to create a zero along with the pole as shown in the UC39431 shunt regulator application. The error amplifier must slew 2.0V to drive the transconductance amplifier initially on.

VCC: The power connection for the device. The minimum to maximum operating voltage is 2.2V to 24.0V. The quiescent current is typically 0.50mA.

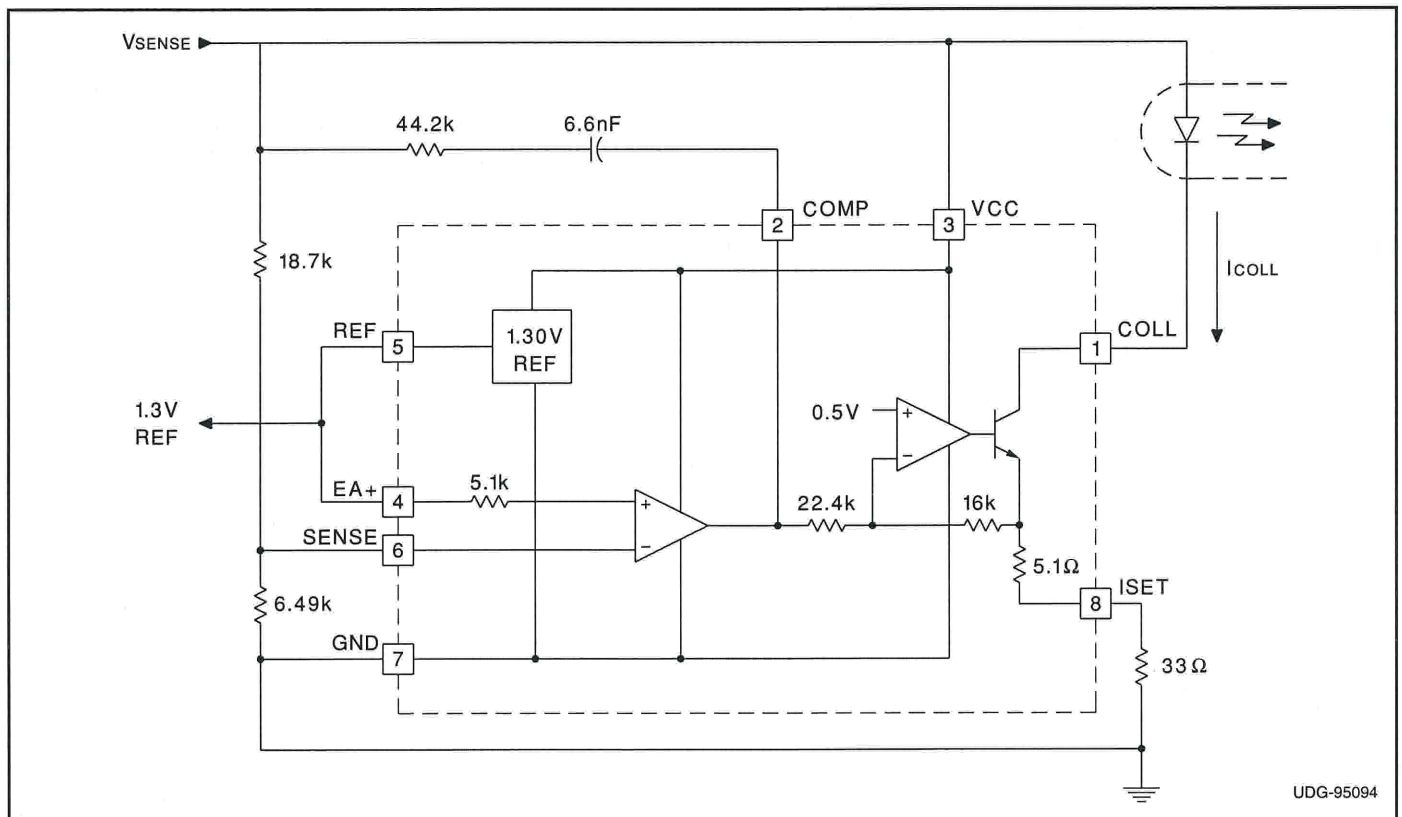

Figure 1. 5.0V Optocoupler application.

OVERVOLTAGE COMPARATOR APPLICATION

The signal V_{IN} senses the input voltage. As long as the input voltage is less than 5.5V, the output is equal to the voltage on V_{IN} . During this region of operation, the diode is reversed biased which keeps the EA+ pin at 1.3V. When V_{IN} exceeds the over voltage threshold of 5.5V, the output is driven low. This forward biases the diode and creates hysteresis by changing the threshold to 4.5V.

OPTOCOPLER APPLICATION

The optocoupler application shown takes advantage of the accessible pins REF and ISET. The ISET pin has a 33 ohm resistor to ground that protects the opto-couler by limiting the current to about 16mA. This also lowers the transconductance to approximately 19mS. The ability to adjust the transconductance gives the designer further control of the loop gain. The REF pin is available to satisfy any high precision voltage requirements.

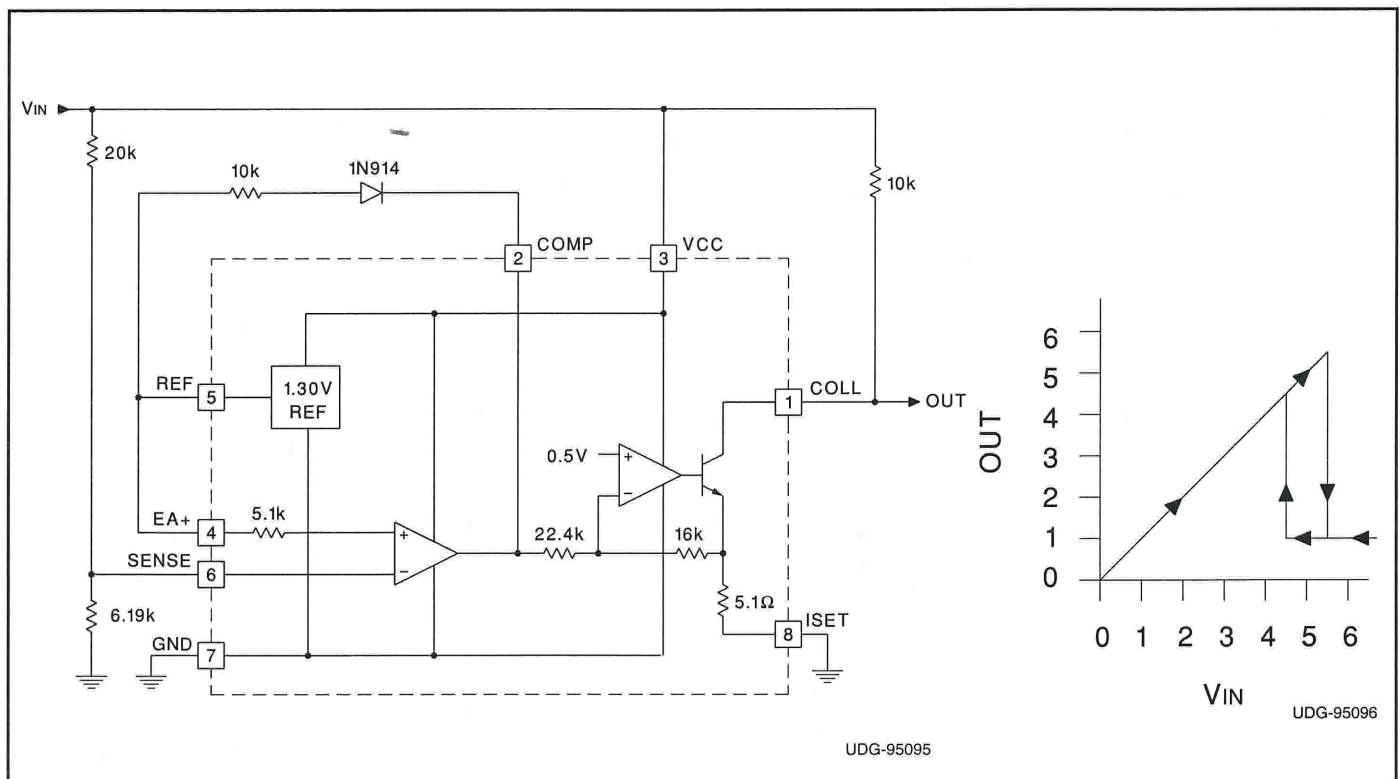

Figure 2. 5.5V Overvoltage comparator with hysteresis.

PACKAGING INFORMATION

Orderable Device	Status ⁽¹⁾	Package Type	Package Drawing	Pins	Package Qty	Eco Plan ⁽²⁾	Lead/Ball Finish	MSL Peak Temp ⁽³⁾
UC19432J	OBSOLETE	CDIP	JG	8		TBD	Call TI	Call TI
UC19432J883B	OBSOLETE	CDIP	JG	8		TBD	Call TI	Call TI
UC29432D	ACTIVE	SOIC	D	8	75	Green (RoHS & no Sb/Br)	CU NIPDAU	Level-2-260C-1 YEAR
UC29432DG4	ACTIVE	SOIC	D	8	75	Green (RoHS & no Sb/Br)	CU NIPDAU	Level-2-260C-1 YEAR
UC29432DTR	NRND	SOIC	D	8	2500	Green (RoHS & no Sb/Br)	CU NIPDAU	Level-2-260C-1 YEAR
UC29432DTRG4	NRND	SOIC	D	8	2500	Green (RoHS & no Sb/Br)	CU NIPDAU	Level-2-260C-1 YEAR
UC29432N	ACTIVE	PDIP	P	8	50	Green (RoHS & no Sb/Br)	CU NIPDAU	N / A for Pkg Type
UC29432NG4	ACTIVE	PDIP	P	8	50	Green (RoHS & no Sb/Br)	CU NIPDAU	N / A for Pkg Type
UC39432BD	ACTIVE	SOIC	D	8	75	Green (RoHS & no Sb/Br)	CU NIPDAU	Level-2-260C-1 YEAR
UC39432BDG4	ACTIVE	SOIC	D	8	75	Green (RoHS & no Sb/Br)	CU NIPDAU	Level-2-260C-1 YEAR
UC39432BDTR	ACTIVE	SOIC	D	8	2500	Green (RoHS & no Sb/Br)	CU NIPDAU	Level-2-260C-1 YEAR
UC39432BDTRG4	ACTIVE	SOIC	D	8	2500	Green (RoHS & no Sb/Br)	CU NIPDAU	Level-2-260C-1 YEAR
UC39432BN	ACTIVE	PDIP	P	8	50	Green (RoHS & no Sb/Br)	CU NIPDAU	N / A for Pkg Type
UC39432BNG4	ACTIVE	PDIP	P	8	50	Green (RoHS & no Sb/Br)	CU NIPDAU	N / A for Pkg Type
UC39432D	ACTIVE	SOIC	D	8	75	Green (RoHS & no Sb/Br)	CU NIPDAU	Level-2-260C-1 YEAR
UC39432DG4	ACTIVE	SOIC	D	8	75	Green (RoHS & no Sb/Br)	CU NIPDAU	Level-2-260C-1 YEAR
UC39432N	ACTIVE	PDIP	P	8	50	Green (RoHS & no Sb/Br)	CU NIPDAU	N / A for Pkg Type
UC39432NG4	ACTIVE	PDIP	P	8	50	Green (RoHS & no Sb/Br)	CU NIPDAU	N / A for Pkg Type

⁽¹⁾ The marketing status values are defined as follows:

ACTIVE: Product device recommended for new designs.

LIFEBUY: TI has announced that the device will be discontinued, and a lifetime-buy period is in effect.

NRND: Not recommended for new designs. Device is in production to support existing customers, but TI does not recommend using this part in a new design.

PREVIEW: Device has been announced but is not in production. Samples may or may not be available.

OBSOLETE: TI has discontinued the production of the device.

⁽²⁾ Eco Plan - The planned eco-friendly classification: Pb-Free (RoHS), Pb-Free (RoHS Exempt), or Green (RoHS & no Sb/Br) - please check <http://www.ti.com/productcontent> for the latest availability information and additional product content details.

TBD: The Pb-Free/Green conversion plan has not been defined.

Pb-Free (RoHS): TI's terms "Lead-Free" or "Pb-Free" mean semiconductor products that are compatible with the current RoHS requirements for all 6 substances, including the requirement that lead not exceed 0.1% by weight in homogeneous materials. Where designed to be soldered at high temperatures, TI Pb-Free products are suitable for use in specified lead-free processes.

Pb-Free (RoHS Exempt): This component has a RoHS exemption for either 1) lead-based flip-chip solder bumps used between the die and package, or 2) lead-based die adhesive used between the die and leadframe. The component is otherwise considered Pb-Free (RoHS compatible) as defined above.

Green (RoHS & no Sb/Br): TI defines "Green" to mean Pb-Free (RoHS compatible), and free of Bromine (Br) and Antimony (Sb) based flame retardants (Br or Sb do not exceed 0.1% by weight in homogeneous material)

⁽³⁾ MSL, Peak Temp. -- The Moisture Sensitivity Level rating according to the JEDEC industry standard classifications, and peak solder temperature.

Important Information and Disclaimer:The information provided on this page represents TI's knowledge and belief as of the date that it is provided. TI bases its knowledge and belief on information provided by third parties, and makes no representation or warranty as to the accuracy of such information. Efforts are underway to better integrate information from third parties. TI has taken and continues to take reasonable steps to provide representative and accurate information but may not have conducted destructive testing or chemical analysis on incoming materials and chemicals. TI and TI suppliers consider certain information to be proprietary, and thus CAS numbers and other limited information may not be available for release.

In no event shall TI's liability arising out of such information exceed the total purchase price of the TI part(s) at issue in this document sold by TI to Customer on an annual basis.

TAPE AND REEL INFORMATION

QUADRANT ASSIGNMENTS FOR PIN 1 ORIENTATION IN TAPE

*All dimensions are nominal

Device	Package Type	Package Drawing	Pins	SPQ	Reel Diameter (mm)	Reel Width W1 (mm)	A0 (mm)	B0 (mm)	K0 (mm)	P1 (mm)	W (mm)	Pin1 Quadrant
UC29432DTR	SOIC	D	8	2500	330.0	12.4	6.4	5.2	2.1	8.0	12.0	Q1
UC39432BDTR	SOIC	D	8	2500	330.0	12.4	6.4	5.2	2.1	8.0	12.0	Q1

TAPE AND REEL BOX DIMENSIONS



*All dimensions are nominal

Device	Package Type	Package Drawing	Pins	SPQ	Length (mm)	Width (mm)	Height (mm)
UC29432DTR	SOIC	D	8	2500	346.0	346.0	29.0
UC39432BDTR	SOIC	D	8	2500	346.0	346.0	29.0

IMPORTANT NOTICE

Texas Instruments Incorporated and its subsidiaries (TI) reserve the right to make corrections, modifications, enhancements, improvements, and other changes to its products and services at any time and to discontinue any product or service without notice. Customers should obtain the latest relevant information before placing orders and should verify that such information is current and complete. All products are sold subject to TI's terms and conditions of sale supplied at the time of order acknowledgment.

TI warrants performance of its hardware products to the specifications applicable at the time of sale in accordance with TI's standard warranty. Testing and other quality control techniques are used to the extent TI deems necessary to support this warranty. Except where mandated by government requirements, testing of all parameters of each product is not necessarily performed.

TI assumes no liability for applications assistance or customer product design. Customers are responsible for their products and applications using TI components. To minimize the risks associated with customer products and applications, customers should provide adequate design and operating safeguards.

TI does not warrant or represent that any license, either express or implied, is granted under any TI patent right, copyright, mask work right, or other TI intellectual property right relating to any combination, machine, or process in which TI products or services are used. Information published by TI regarding third-party products or services does not constitute a license from TI to use such products or services or a warranty or endorsement thereof. Use of such information may require a license from a third party under the patents or other intellectual property of the third party, or a license from TI under the patents or other intellectual property of TI.

Reproduction of TI information in TI data books or data sheets is permissible only if reproduction is without alteration and is accompanied by all associated warranties, conditions, limitations, and notices. Reproduction of this information with alteration is an unfair and deceptive business practice. TI is not responsible or liable for such altered documentation. Information of third parties may be subject to additional restrictions.

Resale of TI products or services with statements different from or beyond the parameters stated by TI for that product or service voids all express and any implied warranties for the associated TI product or service and is an unfair and deceptive business practice. TI is not responsible or liable for any such statements.

TI products are not authorized for use in safety-critical applications (such as life support) where a failure of the TI product would reasonably be expected to cause severe personal injury or death, unless officers of the parties have executed an agreement specifically governing such use. Buyers represent that they have all necessary expertise in the safety and regulatory ramifications of their applications, and acknowledge and agree that they are solely responsible for all legal, regulatory and safety-related requirements concerning their products and any use of TI products in such safety-critical applications, notwithstanding any applications-related information or support that may be provided by TI. Further, Buyers must fully indemnify TI and its representatives against any damages arising out of the use of TI products in such safety-critical applications.

TI products are neither designed nor intended for use in military/aerospace applications or environments unless the TI products are specifically designated by TI as military-grade or "enhanced plastic." Only products designated by TI as military-grade meet military specifications. Buyers acknowledge and agree that any such use of TI products which TI has not designated as military-grade is solely at the Buyer's risk, and that they are solely responsible for compliance with all legal and regulatory requirements in connection with such use.

TI products are neither designed nor intended for use in automotive applications or environments unless the specific TI products are designated by TI as compliant with ISO/TS 16949 requirements. Buyers acknowledge and agree that, if they use any non-designated products in automotive applications, TI will not be responsible for any failure to meet such requirements.

Following are URLs where you can obtain information on other Texas Instruments products and application solutions:

Products

Amplifiers	amplifier.ti.com
Data Converters	dataconverter.ti.com
DLP® Products	www.dlp.com
DSP	dsp.ti.com
Clocks and Timers	www.ti.com/clocks
Interface	interface.ti.com
Logic	logic.ti.com
Power Mgmt	power.ti.com
Microcontrollers	microcontroller.ti.com
RFID	www.ti-rfid.com
RF/IF and ZigBee® Solutions	www.ti.com/lprf

Applications

Audio	www.ti.com/audio
Automotive	www.ti.com/automotive
Broadband	www.ti.com/broadband
Digital Control	www.ti.com/digitalcontrol
Medical	www.ti.com/medical
Military	www.ti.com/military
Optical Networking	www.ti.com/opticalnetwork
Security	www.ti.com/security
Telephony	www.ti.com/telephony
Video & Imaging	www.ti.com/video
Wireless	www.ti.com/wireless

Mailing Address: Texas Instruments, Post Office Box 655303, Dallas, Texas 75265
Copyright © 2009, Texas Instruments Incorporated