

27-Line SCSI Terminator

FEATURES

- Complies with SCSI, SCSI-2, SCSI-3, SPI and FAST-20 (Ultra) Standards
- 2.5pF Channel Capacitance during Disconnect
- 100mA Supply Current in Disconnect Mode
- 4V To 7V Operation
- 110Ω Termination
- Completely Meets SCSI Hot Plugging
- -900mA Sourcing Current for Termination
- +500mA Sinking Current for Active Negation
- Logic Command Disconnects all Termination Lines
- Trimmed Impedance to 5%
- Current Limit and Thermal Shutdown Protection

DESCRIPTION

UCC5620 provides 27 lines of active termination for a SCSI (Small Computer Systems Interface) parallel bus. The SCSI standard recommends active termination at both ends of the cable.

The UCC5620 is ideal for high performance 5V SCSI systems. During disconnect the supply current is typically only 100μA, which makes the IC attractive for lower powered systems.

The UCC5620 is designed with a low channel capacitance of 2.5pF, which eliminates effects on signal integrity from disconnected terminators at interim points on the bus.

The power amplifier output stage allows the UCC5620 to source full termination current and sink active negation current when all termination lines are actively negated.

The UCC5620, as with all Unitrode terminators, is completely hot pluggable and appears as high impedance at the terminating channels with $V_{TRMPWR} = 0V$ or open.

Internal circuit trimming is utilized, first to trim the 110Ω impedance, and then most importantly, to trim the output current as close to the maximum SCSI-3 specification as possible, which maximizes noise margin in fast SCSI operation.

Other features include thermal shutdown and current limit. This device is offered in low thermal resistance versions of the industry standard 36-Pin Wide Body QSOP (MWP).

Consult QSOP-36 packaging diagram for exact dimensions.

BLOCK DIAGRAM

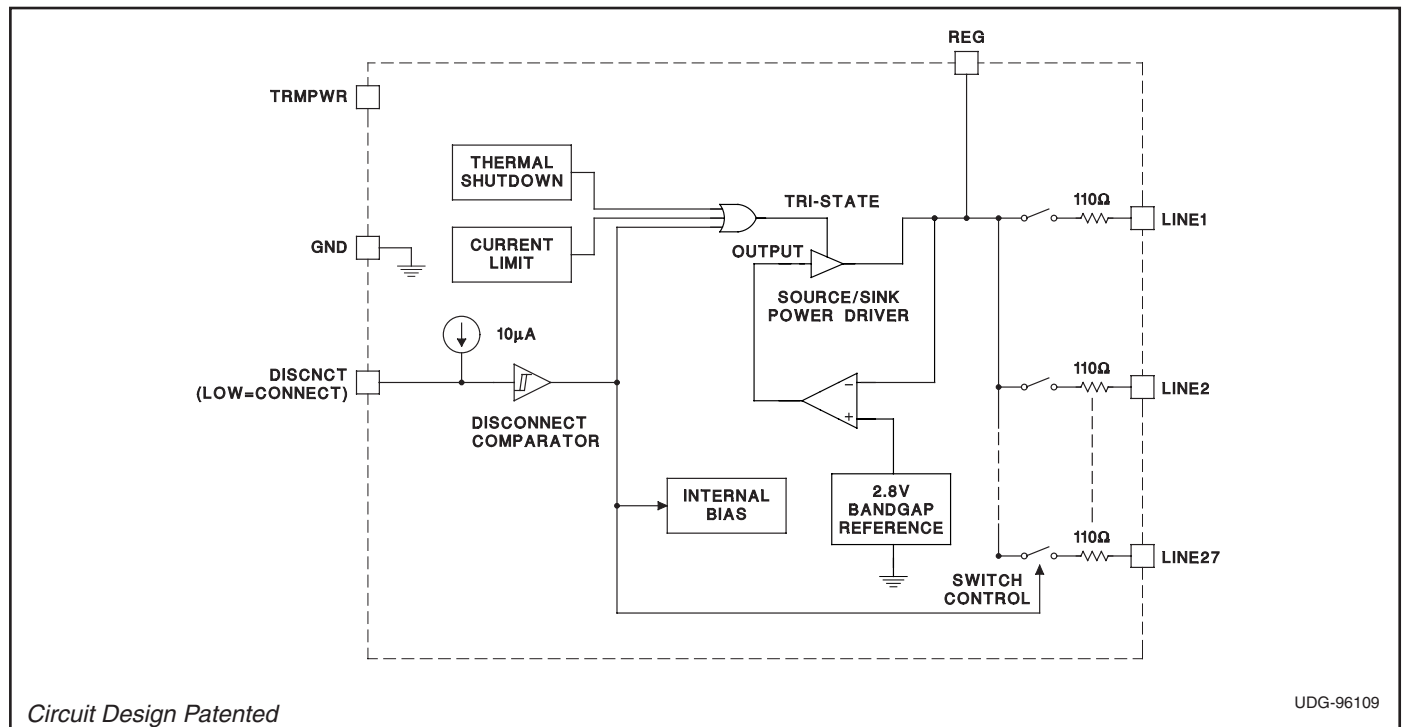

Circuit Design Patented

UDG-96109

ABSOLUTE MAXIMUM RATINGS

Tempwr Voltage	+7V
Signal Line Voltage	0V to +7V
Regulator Output Current	1.5A
Storage Temperature	-65°C to +150°C
Junction Temperature	-55°C to +150°C
Lead Temperature (Soldering, 10 Sec.)	+300°C

Currents are positive into, negative out of the specified terminal. Consult Packaging Section of Databook for thermal limitations and considerations of packages.

CONNECTION DIAGRAM

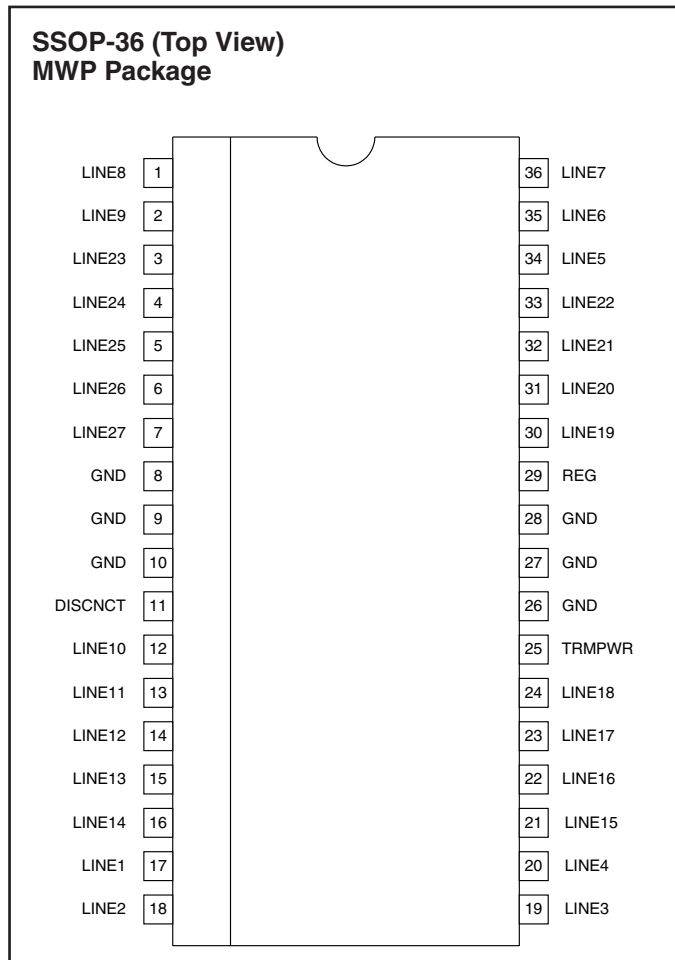

ELECTRICAL CHARACTERISTICS Unless otherwise stated, these specifications apply for $T_A = 0^\circ\text{C}$ to 70°C , TRMPWR = 4.75V, DISCNCT = 0V, $T_A = T_J$.

PARAMETER	TEST CONDITIONS	MIN	TYP	MAX	UNITS
Supply Current Section					
TRMPWR Supply Current	All Termination Lines = Open		1	2	mA
	All Termination Lines = 0.2V		630	650	mA
Power Down Mode	DISCNCT = TRMPWR		100	200	μA
Output Section (Termination Lines)					
Termination Impedance	(Note 3)	104.5	110	115.5	Ω
Output High Voltage	(Note 1)	2.6	2.8	3.0	V
Max Output Current	$V_{\text{LINE}} = 0.2\text{V}$, $T_J = 25^\circ\text{C}$	-22.1	-23.3	-24	mA
	$V_{\text{LINE}} = 0.2\text{V}$	-20.7	-23.3	-24	mA
	$V_{\text{LINE}} = 0.2\text{V}$, TRMPWR = 4V, $T_J = 25^\circ\text{C}$ (Note 1)	-21	-23	-24	mA
	$V_{\text{LINE}} = 0.2\text{V}$, TRMPWR = 4V (Note 1)	-20	-23	-24	mA
	$V_{\text{LINE}} = 0.5\text{V}$			-22.4	mA
Output Leakage	DISCNCT = 2.4V, TRMPWR = 0V to 5.25V		10	400	nA
Output Capacitance	DISCNCT = 2.4V (Note 2)		2.5	4	pF

ELECTRICAL CHARACTERISTICS Unless otherwise stated, these specifications apply for $T_A = 0^{\circ}\text{C}$ to 70°C , $\text{TRMPWR} = 4.75\text{V}$, $\text{DISCNCT} = 0\text{V}$, $T_A = T_J$.

PARAMETER	TEST CONDITIONS	MIN	TYP	MAX	UNITS
Regulator Section					
Regulator Output Voltage		2.6	2.8	3.0	V
Drop Out Voltage	All Termination Lines = 0.2V		0.4	0.8	V
Short Circuit Current	$V_{\text{REG}} = 0\text{V}$	-650	-900	-1300	mA
Sinking Current Capability	$V_{\text{REG}} = 3.5\text{V}$	300	500	900	mA
Thermal Shutdown			170		$^{\circ}\text{C}$
Thermal Shutdown Hysteresis			10		$^{\circ}\text{C}$
Disconnect Section					
Disconnect Threshold		0.8	1.5	2.0	V
Input Current	$\text{DISCNCT} = 0\text{V}$		-20	-60	μA

Note 1: Measuring each termination line while other 26 are low (0.2V).

Note 2: Ensured by design. Not 100% tested in production.

Note 3: Tested by measuring I_{OUT} with $V_{\text{OUT}} = 0.2\text{V}$ and V_{OUT} with no load, then calculate: $Z = \frac{(V_{\text{OUT}} \text{ N.L.} - 0.2\text{V})}{I_{\text{OUT}} \text{ at } 0.2\text{V}}$

PIN DESCRIPTIONS

DISCNCT: Taking this pin high or leaving it open causes all channels to become high impedance, and the chip to go into low-power mode; a low state allows the channels to provide normal termination.

GND: Ground reference for the IC.

LINE1 - LINE27: 110Ω termination channels.

REG: Output of the internal 2.7V regulator.

TRMPWR: Power for the IC.

APPLICATION INFORMATION

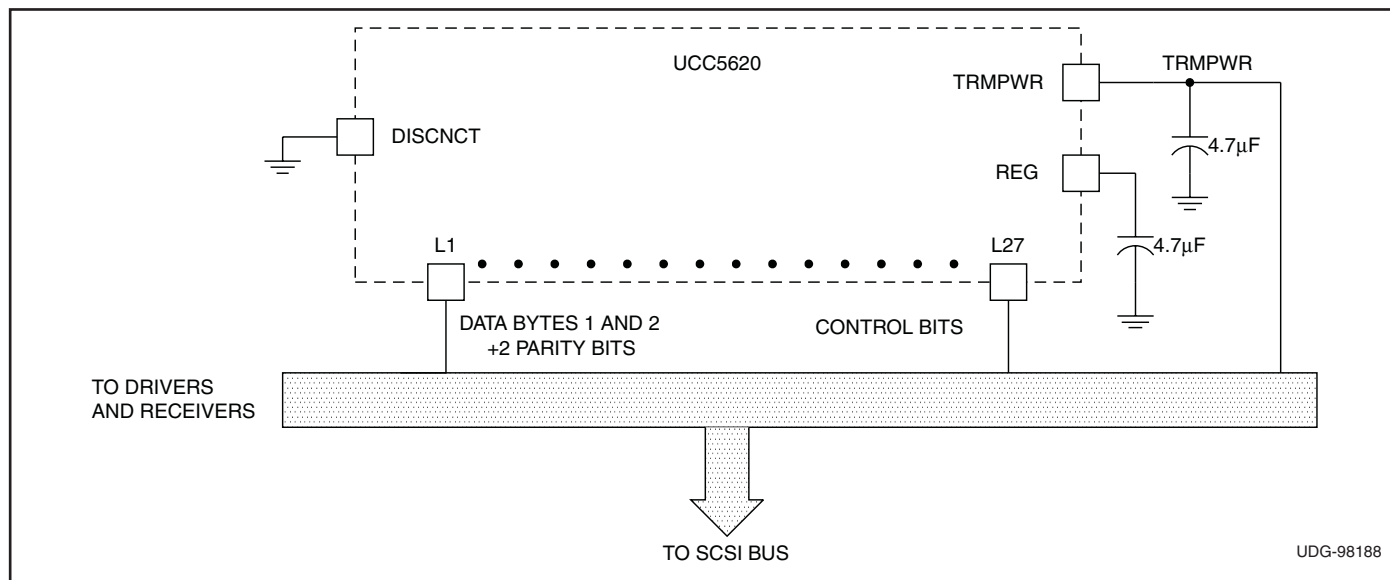

Figure 1. Typical Wide SCSI Bus Configuration Using the UCC5620

PACKAGING INFORMATION

Orderable Device	Status ⁽¹⁾	Package Type	Package Drawing	Pins	Package Qty	Eco Plan ⁽²⁾	Lead/Ball Finish	MSL Peak Temp ⁽³⁾
UCC5620FQPTR	OBSOLETE	LQFP	PT	48		TBD	Call TI	Call TI
UCC5620MWP	ACTIVE	SSOP	DCE	36	25	Green (RoHS & no Sb/Br)	CU NIPDAU	Level-1-260C-UNLIM
UCC5620MWPG4	ACTIVE	SSOP	DCE	36	25	Green (RoHS & no Sb/Br)	CU NIPDAU	Level-1-260C-UNLIM
UCC5620MWPTR	ACTIVE	SSOP	DCE	36	1000	Green (RoHS & no Sb/Br)	CU NIPDAU	Level-1-260C-UNLIM
UCC5620MWPTRG4	ACTIVE	SSOP	DCE	36	1000	Green (RoHS & no Sb/Br)	CU NIPDAU	Level-1-260C-UNLIM

⁽¹⁾ The marketing status values are defined as follows:

ACTIVE: Product device recommended for new designs.

LIFEBUY: TI has announced that the device will be discontinued, and a lifetime-buy period is in effect.

NRND: Not recommended for new designs. Device is in production to support existing customers, but TI does not recommend using this part in a new design.

PREVIEW: Device has been announced but is not in production. Samples may or may not be available.

OBSOLETE: TI has discontinued the production of the device.

⁽²⁾ Eco Plan - The planned eco-friendly classification: Pb-Free (RoHS), Pb-Free (RoHS Exempt), or Green (RoHS & no Sb/Br) - please check <http://www.ti.com/productcontent> for the latest availability information and additional product content details.

TBD: The Pb-Free/Green conversion plan has not been defined.

Pb-Free (RoHS): TI's terms "Lead-Free" or "Pb-Free" mean semiconductor products that are compatible with the current RoHS requirements for all 6 substances, including the requirement that lead not exceed 0.1% by weight in homogeneous materials. Where designed to be soldered at high temperatures, TI Pb-Free products are suitable for use in specified lead-free processes.

Pb-Free (RoHS Exempt): This component has a RoHS exemption for either 1) lead-based flip-chip solder bumps used between the die and package, or 2) lead-based die adhesive used between the die and leadframe. The component is otherwise considered Pb-Free (RoHS compatible) as defined above.

Green (RoHS & no Sb/Br): TI defines "Green" to mean Pb-Free (RoHS compatible), and free of Bromine (Br) and Antimony (Sb) based flame retardants (Br or Sb do not exceed 0.1% by weight in homogeneous material)

⁽³⁾ MSL, Peak Temp. -- The Moisture Sensitivity Level rating according to the JEDEC industry standard classifications, and peak solder temperature.

Important Information and Disclaimer:The information provided on this page represents TI's knowledge and belief as of the date that it is provided. TI bases its knowledge and belief on information provided by third parties, and makes no representation or warranty as to the accuracy of such information. Efforts are underway to better integrate information from third parties. TI has taken and continues to take reasonable steps to provide representative and accurate information but may not have conducted destructive testing or chemical analysis on incoming materials and chemicals. TI and TI suppliers consider certain information to be proprietary, and thus CAS numbers and other limited information may not be available for release.

In no event shall TI's liability arising out of such information exceed the total purchase price of the TI part(s) at issue in this document sold by TI to Customer on an annual basis.

TAPE AND REEL INFORMATION

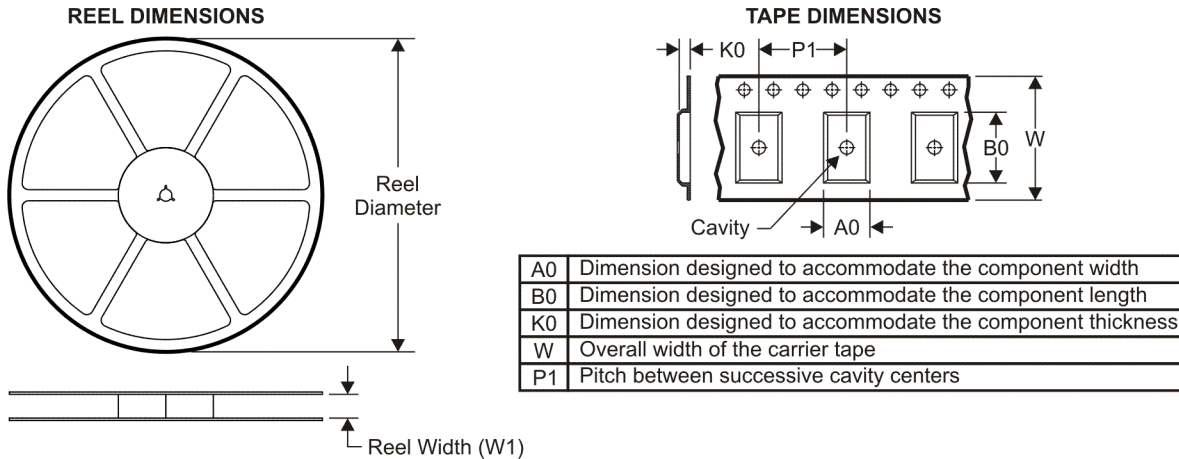

QUADRANT ASSIGNMENTS FOR PIN 1 ORIENTATION IN TAPE

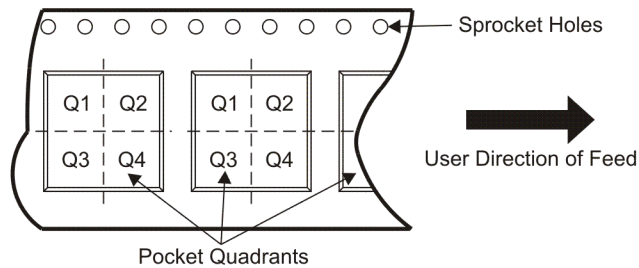

*All dimensions are nominal

Device	Package Type	Package Drawing	Pins	SPQ	Reel Diameter (mm)	Reel Width W1 (mm)	A0 (mm)	B0 (mm)	K0 (mm)	P1 (mm)	W (mm)	Pin1 Quadrant
UCC5620MWPTR	SSOP	DCE	36	1000	330.0	24.4	10.85	15.8	2.7	12.0	24.0	Q1

TAPE AND REEL BOX DIMENSIONS

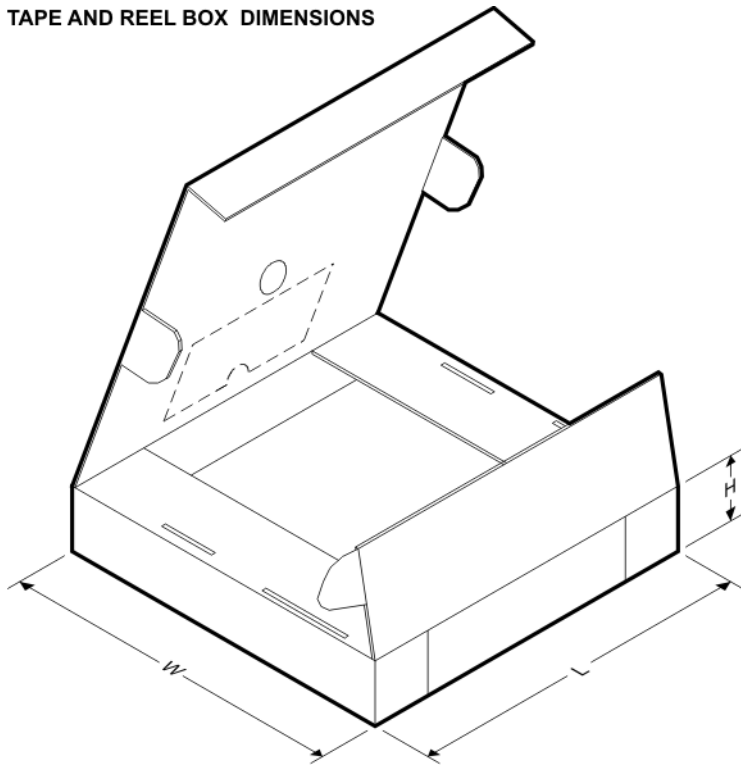

*All dimensions are nominal

Device	Package Type	Package Drawing	Pins	SPQ	Length (mm)	Width (mm)	Height (mm)
UCC5620MWPTR	SSOP	DCE	36	1000	346.0	346.0	41.0

PT (S-PQFP-G48)

PLASTIC QUAD FLATPACK

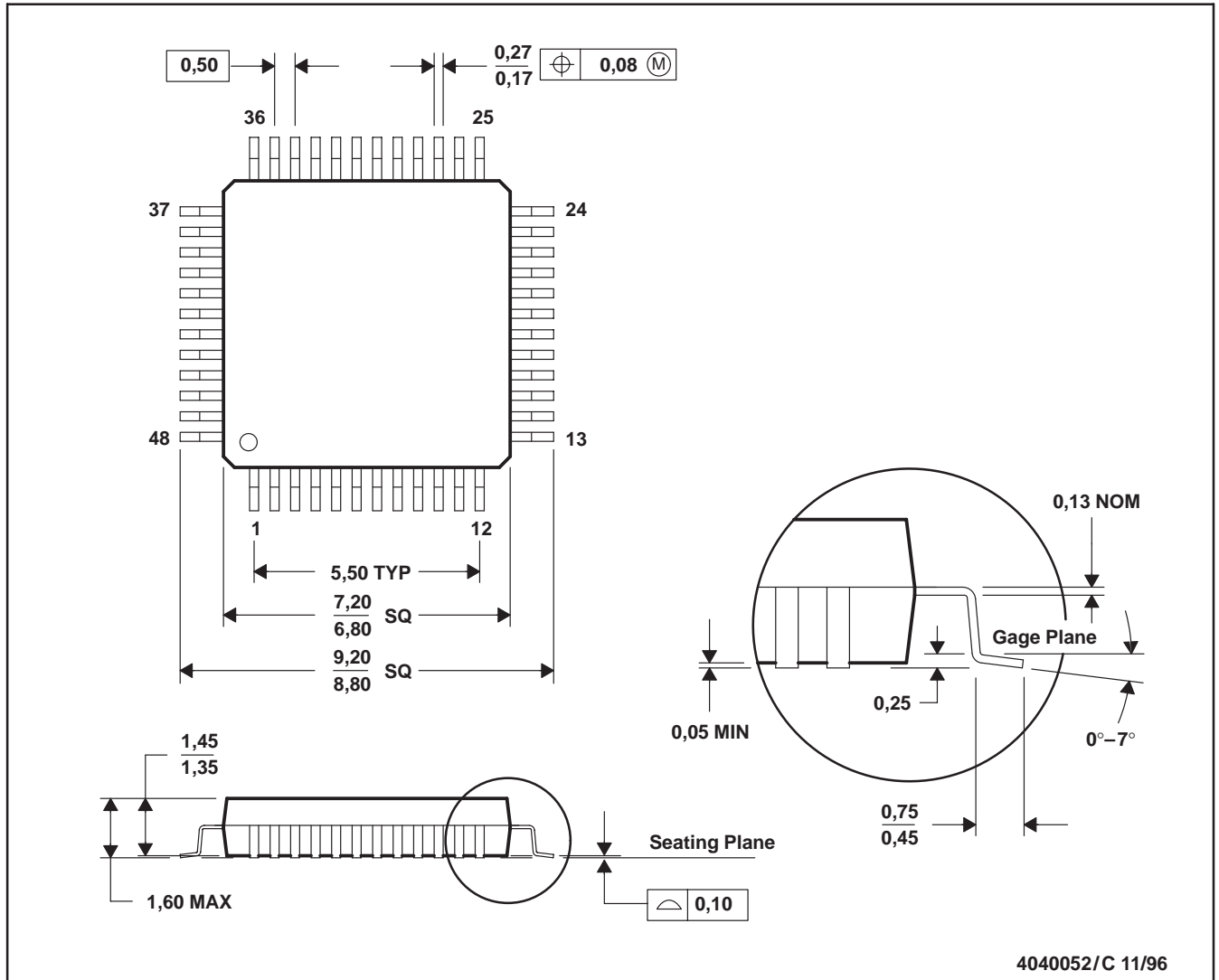

- NOTES: A. All linear dimensions are in millimeters.
 B. This drawing is subject to change without notice.
 C. Falls within JEDEC MS-026
 D. This may also be a thermally enhanced plastic package with leads connected to the die pads.

DCE (R-PDSO-G**) 36 PINS SHOWN

PLASTIC SMALL-OUTLINE

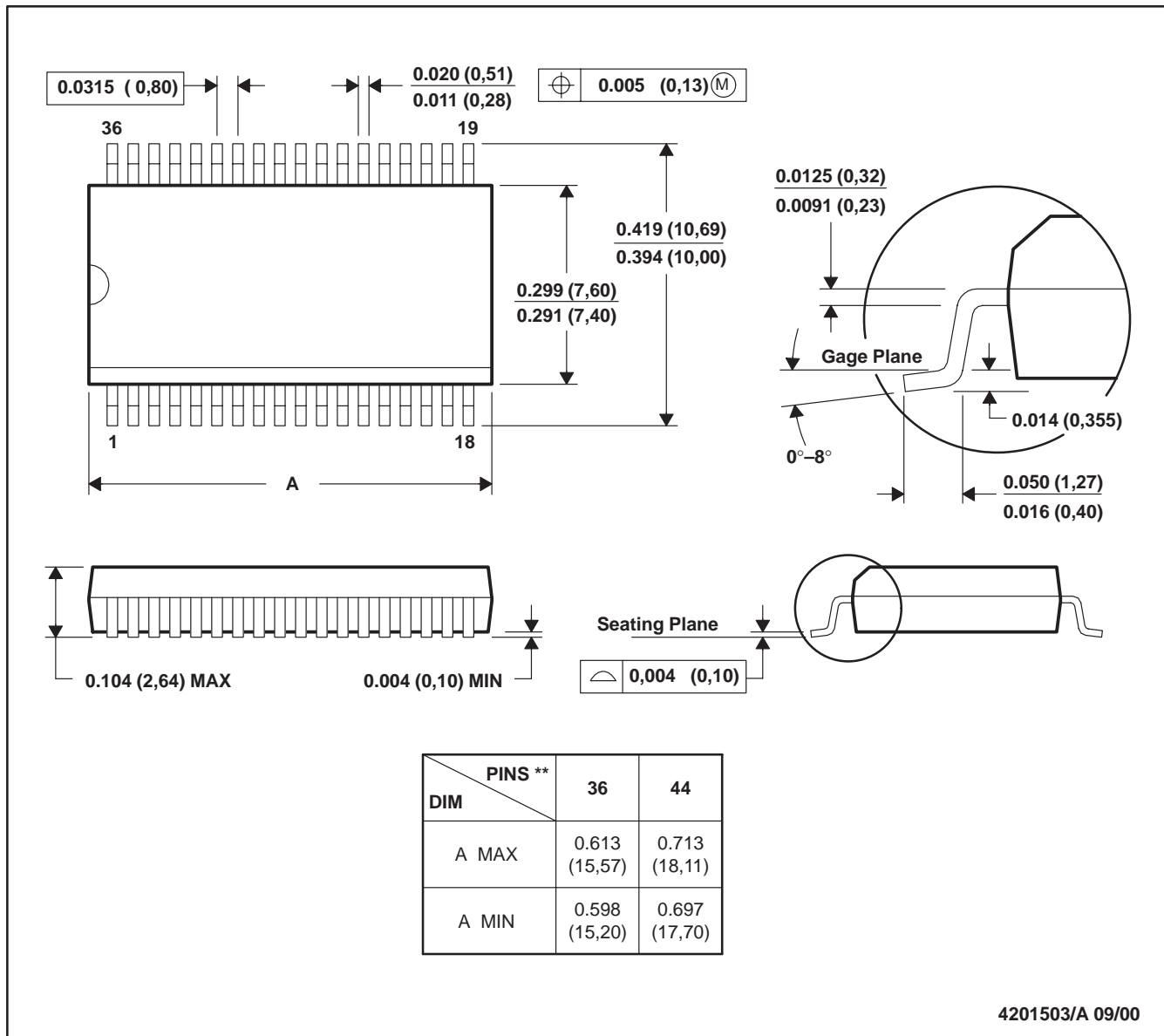

- NOTES: A. All linear dimensions are in millimeters.
 B. This drawing is subject to change without notice.
 C. Body dimensions do not include mold flash or protrusion not to exceed 0.006 (0,15).

IMPORTANT NOTICE

Texas Instruments Incorporated and its subsidiaries (TI) reserve the right to make corrections, modifications, enhancements, improvements, and other changes to its products and services at any time and to discontinue any product or service without notice. Customers should obtain the latest relevant information before placing orders and should verify that such information is current and complete. All products are sold subject to TI's terms and conditions of sale supplied at the time of order acknowledgment.

TI warrants performance of its hardware products to the specifications applicable at the time of sale in accordance with TI's standard warranty. Testing and other quality control techniques are used to the extent TI deems necessary to support this warranty. Except where mandated by government requirements, testing of all parameters of each product is not necessarily performed.

TI assumes no liability for applications assistance or customer product design. Customers are responsible for their products and applications using TI components. To minimize the risks associated with customer products and applications, customers should provide adequate design and operating safeguards.

TI does not warrant or represent that any license, either express or implied, is granted under any TI patent right, copyright, mask work right, or other TI intellectual property right relating to any combination, machine, or process in which TI products or services are used. Information published by TI regarding third-party products or services does not constitute a license from TI to use such products or services or a warranty or endorsement thereof. Use of such information may require a license from a third party under the patents or other intellectual property of the third party, or a license from TI under the patents or other intellectual property of TI.

Reproduction of TI information in TI data books or data sheets is permissible only if reproduction is without alteration and is accompanied by all associated warranties, conditions, limitations, and notices. Reproduction of this information with alteration is an unfair and deceptive business practice. TI is not responsible or liable for such altered documentation. Information of third parties may be subject to additional restrictions.

Resale of TI products or services with statements different from or beyond the parameters stated by TI for that product or service voids all express and any implied warranties for the associated TI product or service and is an unfair and deceptive business practice. TI is not responsible or liable for any such statements.

TI products are not authorized for use in safety-critical applications (such as life support) where a failure of the TI product would reasonably be expected to cause severe personal injury or death, unless officers of the parties have executed an agreement specifically governing such use. Buyers represent that they have all necessary expertise in the safety and regulatory ramifications of their applications, and acknowledge and agree that they are solely responsible for all legal, regulatory and safety-related requirements concerning their products and any use of TI products in such safety-critical applications, notwithstanding any applications-related information or support that may be provided by TI. Further, Buyers must fully indemnify TI and its representatives against any damages arising out of the use of TI products in such safety-critical applications.

TI products are neither designed nor intended for use in military/aerospace applications or environments unless the TI products are specifically designated by TI as military-grade or "enhanced plastic." Only products designated by TI as military-grade meet military specifications. Buyers acknowledge and agree that any such use of TI products which TI has not designated as military-grade is solely at the Buyer's risk, and that they are solely responsible for compliance with all legal and regulatory requirements in connection with such use.

TI products are neither designed nor intended for use in automotive applications or environments unless the specific TI products are designated by TI as compliant with ISO/TS 16949 requirements. Buyers acknowledge and agree that, if they use any non-designated products in automotive applications, TI will not be responsible for any failure to meet such requirements.

Following are URLs where you can obtain information on other Texas Instruments products and application solutions:

Products

Amplifiers	amplifier.ti.com
Data Converters	dataconverter.ti.com
DLP® Products	www.dlp.com
DSP	dsp.ti.com
Clocks and Timers	www.ti.com/clocks
Interface	interface.ti.com
Logic	logic.ti.com
Power Mgmt	power.ti.com
Microcontrollers	microcontroller.ti.com
RFID	www.ti-rfid.com
RF/IF and ZigBee® Solutions	www.ti.com/lprf

Applications

Audio	www.ti.com/audio
Automotive	www.ti.com/automotive
Broadband	www.ti.com/broadband
Digital Control	www.ti.com/digitalcontrol
Medical	www.ti.com/medical
Military	www.ti.com/military
Optical Networking	www.ti.com/opticalnetwork
Security	www.ti.com/security
Telephony	www.ti.com/telephony
Video & Imaging	www.ti.com/video
Wireless	www.ti.com/wireless

Mailing Address: Texas Instruments, Post Office Box 655303, Dallas, Texas 75265
Copyright © 2009, Texas Instruments Incorporated