

Table of Contents

1 Features	1	7.2 Functional Block Diagram	13
2 Applications	1	7.3 Feature Description	13
3 Description	1	8 Application and Implementation	40
4 Revision History	2	8.1 Application Information	40
5 Pin Configuration and Functions	3	8.2 Typical Application	40
6 Specifications	8	9 Power Supply Recommendations	43
6.1 Absolute Maximum Ratings	8	10 Layout	43
6.2 ESD Ratings	8	10.1 Layout Guidelines	43
6.3 Recommended Operating Conditions	8	10.2 Layout Example	43
6.4 Thermal Information	9	11 Device and Documentation Support	45
6.5 Electrical Characteristics	9	11.1 Trademarks	45
6.6 Nonvolatile Memory Characteristics	10	11.2 Electrostatic Discharge Caution	45
6.7 I ² C/PMBUS Timing Requirements	11	11.3 Glossary	45
7 Detailed Description	12	12 Mechanical, Packaging, and Orderable Information	45
7.1 Device Overview	12		

4 Revision History

DATE	REVISION	NOTES
February 2015	*	Initial release.

5 Pin Configuration and Functions

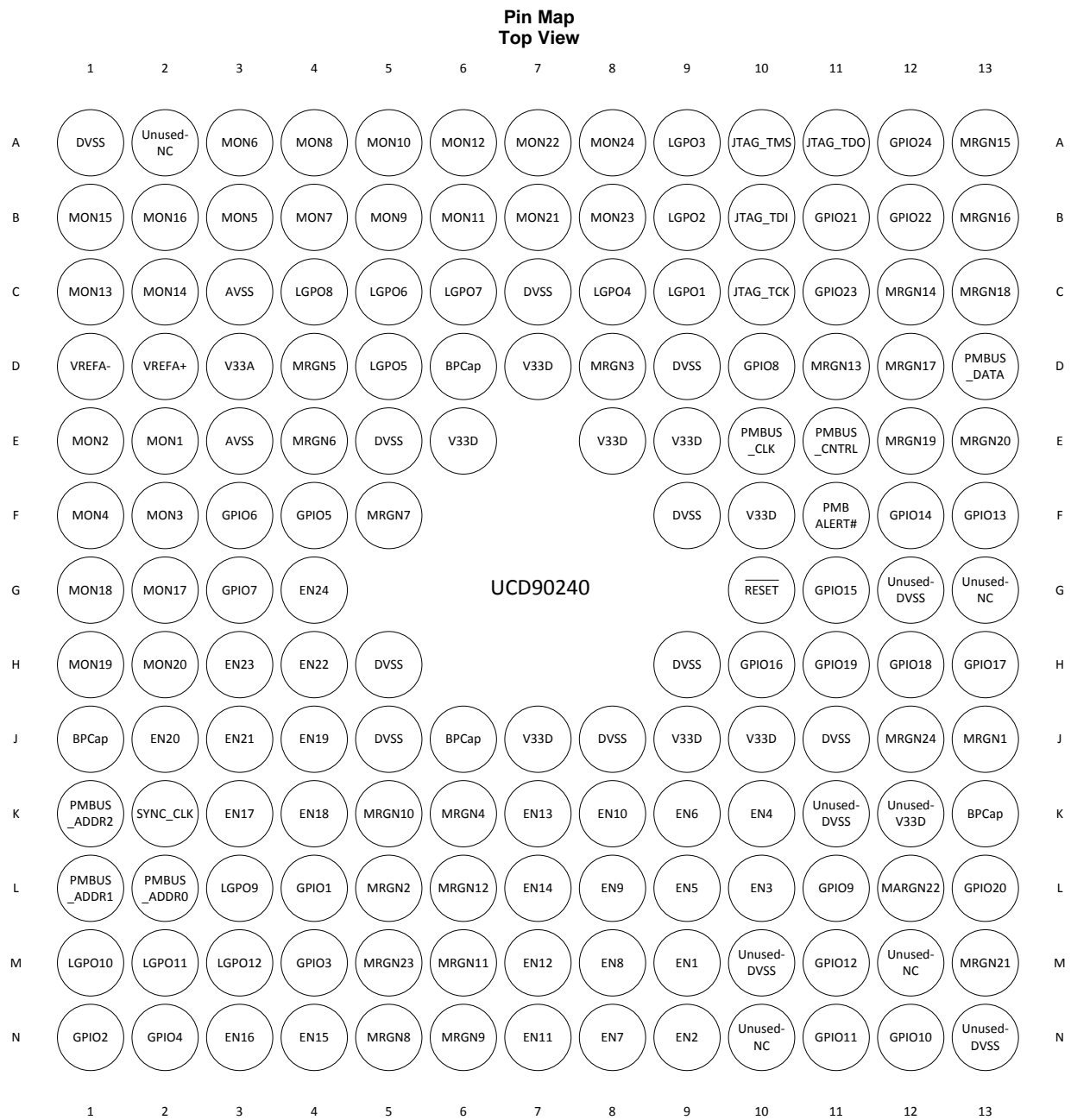

Pin Functions

PIN		I/O TYPE	DESCRIPTION
NAME	NO.		
ANALOG MONITOR PINS			
MON1	E2	I	Analog input monitor pin
MON2	E1	I	Analog input monitor pin
MON3	F2	I	Analog input monitor pin
MON4	F1	I	Analog input monitor pin
MON5	B3	I	Analog input monitor pin
MON6	A3	I	Analog input monitor pin
MON7	B4	I	Analog input monitor pin
MON8	A4	I	Analog input monitor pin
MON9	B5	I	Analog input monitor pin
MON10	A5	I	Analog input monitor pin
MON11	B6	I	Analog input monitor pin
MON12	A6	I	Analog input monitor pin
MON13	C1	I	Analog input monitor pin
MON14	C2	I	Analog input monitor pin
MON15	B1	I	Analog input monitor pin
MON16	B2	I	Analog input monitor pin
MON17	G2	I	Analog input monitor pin
MON18	G1	I	Analog input monitor pin
MON19	H1	I	Analog input monitor pin
MON20	H2	I	Analog input monitor pin
MON21	B7	I	Analog input monitor pin
MON22	A7	I	Analog input monitor pin
MON23	B8	I	Analog input monitor pin
MON24	A8	I	Analog input monitor pin
ENABLE PINS			
EN1	M9	O	Digital output, rail enable signal
EN2	N9	O	Digital output, rail enable signal
EN3	L10	O	Digital output, rail enable signal
EN4	K10	O	Digital output, rail enable signal
EN5	L9	O	Digital output, rail enable signal
EN6	K9	O	Digital output, rail enable signal
EN7	N8	O	Digital output, rail enable signal
EN8	M8	O	Digital output, rail enable signal
EN9	L8	O	Digital output, rail enable signal
EN10	K8	O	Digital output, rail enable signal
EN11	N7	O	Digital output, rail enable signal
EN12	M7	O	Digital output, rail enable signal
EN13	K7	O	Digital output, rail enable signal
EN14	L7	O	Digital output, rail enable signal
EN15	N4	O	Digital output, rail enable signal
EN16	N3	O	Digital output, rail enable signal
EN17	K3	O	Digital output, rail enable signal
EN18	K4	O	Digital output, rail enable signal
EN19	J4	O	Digital output, rail enable signal
EN20	J2	O	Digital output, rail enable signal

Pin Functions (continued)

PIN		I/O TYPE	DESCRIPTION
NAME	NO.		
EN21	J3	O	Digital output, rail enable signal
EN22	H4	O	Digital output, rail enable signal
EN23	H3	O	Digital output, rail enable signal
EN24	G4	O	Digital output, rail enable signal
CLOSED-LOOP MARGIN PINS			
MARGIN1	J13	O	Closed-loop margin PWM output
MARGIN2	L5	O	Closed-loop margin PWM output
MARGIN3	D8	O	Closed-loop margin PWM output
MARGIN4	K6	O	Closed-loop margin PWM output
MARGIN5	D4	O	Closed-loop margin PWM output
MARGIN6	E4	O	Closed-loop margin PWM output
MARGIN7	F5	O	Closed-loop margin PWM output
MARGIN8	N5	O	Closed-loop margin PWM output
MARGIN9	N6	O	Closed-loop margin PWM output
MARGIN10	K5	O	Closed-loop margin PWM output
MARGIN11	M6	O	Closed-loop margin PWM output
MARGIN12	L6	O	Closed-loop margin PWM output
MARGIN13	D11	O	Closed-loop margin PWM output
MARGIN14	C12	O	Closed-loop margin PWM output
MARGIN15	A13	O	Closed-loop margin PWM output
MARGIN16	B13	O	Closed-loop margin PWM output
MARGIN17	D12	O	Closed-loop margin PWM output
MARGIN18	C13	O	Closed-loop margin PWM output
MARGIN19	E12	O	Closed-loop margin PWM output
MARGIN20	E13	O	Closed-loop margin PWM output
MARGIN21	M13	O	Closed-loop margin PWM output
MARGIN22	L12	O	Closed-loop margin PWM output
MARGIN23	M5	O	Closed-loop margin PWM output
MARGIN24	J12	O	Closed-loop margin PWM output
GPIO and CASCADING PINS			
GPIO1	L4	I/O	GPI / Command GPO / WDI / WDO / System Reset / Fault Pin for multiple chip cascading
GPIO2	N1	I/O	GPI / Command GPO / WDI / WDO / System Reset / Fault Pin for multiple chip cascading
GPIO3	M4	I/O	GPI / Command GPO / WDI / WDO / System Reset / Fault Pin for multiple chip cascading
GPIO4	N2	I/O	GPI / Command GPO / WDI / WDO / System Reset / Fault Pin for multiple chip cascading
GPIO5	F4	I/O	GPI / Command GPO / WDI / WDO / System Reset / Fault Pin for multiple chip cascading
GPIO6	F3	I/O	GPI / Command GPO / WDI / WDO / System Reset / Fault Pin for multiple chip cascading
GPIO7	G3	I/O	GPI / Command GPO / WDI / WDO / System Reset / Fault Pin for multiple chip cascading
GPIO8	D10	I/O	GPI / Command GPO / WDI / WDO / System Reset / Fault Pin for multiple chip cascading
GPIO9	L11	I/O	GPI / Command GPO / WDI / WDO / System Reset / Fault Pin for multiple chip cascading
GPIO10	N12	I/O	GPI / Command GPO / WDI / WDO / System Reset / Fault Pin for multiple chip cascading
GPIO11	N11	I/O	GPI / Command GPO / WDI / WDO / System Reset / Fault Pin for multiple chip cascading
GPIO12	M11	I/O	GPI / Command GPO / WDI / WDO / System Reset / Fault Pin for multiple chip cascading
GPIO13	F13	I/O	GPI / Command GPO / WDI / WDO / System Reset / Fault Pin for multiple chip cascading
GPIO14	F12	I/O	GPI / Command GPO / WDI / WDO / System Reset / Fault Pin for multiple chip cascading
GPIO15	G11	I/O	GPI / Command GPO / WDI / WDO / System Reset / Fault Pin for multiple chip cascading
GPIO16	H10	I/O	GPI / Command GPO / WDI / WDO / System Reset / Fault Pin for multiple chip cascading

Pin Functions (continued)

PIN		I/O TYPE	DESCRIPTION
NAME	NO.		
GPIO17	H13	I/O	GPI / Command GPO / WDI / WDO / System Reset / Fault Pin for multiple chip cascading
GPIO18	H12	I/O	GPI / Command GPO / WDI / WDO / System Reset / Fault Pin for multiple chip cascading
GPIO19	H11	I/O	GPI / Command GPO / WDI / WDO / System Reset / Fault Pin for multiple chip cascading
GPIO20	L13	I/O	GPI / Command GPO / WDI / WDO / System Reset / Fault Pin for multiple chip cascading
GPIO21	B11	I/O	GPI / Command GPO / WDI / WDO / System Reset / Fault Pin for multiple chip cascading
GPIO22	B12	I/O	GPI / Command GPO / WDI / WDO / System Reset / Fault Pin for multiple chip cascading
GPIO23	C11	I/O	GPI / Command GPO / WDI / WDO / System Reset / Fault Pin for multiple chip cascading
GPIO24	A12	I/O	GPI / Command GPO / WDI / WDO / System Reset / Fault Pin for multiple chip cascading
SYNC_CLK	K2	I/O	Synchronization clock I/O for multiple chip cascading
Logic GPO PINS			
LGPO1	C9	O	Logic GPO
LGPO2	B9	O	Logic GPO
LGPO3	A9	O	Logic GPO
LGPO4	C8	O	Logic GPO
LGPO5	D5	O	Logic GPO
LGPO6	C5	O	Logic GPO
LGPO7	C6	O	Logic GPO
LGPO8	C4	O	Logic GPO
LGPO9	L3	O	Logic GPO
LGPO10	M1	O	Logic GPO
LGPO11	M2	O	Logic GPO
LGPO12	M3	O	Logic GPO
PMBus COMM INTERFACE			
PMBUS_CLK	E10	I	PMBus clock (must pull up to V33D)
PMBUS_DATA	D13	I/O	PMBus data (must pull up to V33D)
PMBALERT#	F11	O	PMBus alert, active-low, open-drain output (must pull up to V33D)
PMBUS_CNTRL	E11	I	PMBus control pin
PMBUS_ADDR0	L2	I	PMBus digital address input. Bit 0.
PMBUS_ADDR1	L1	I	PMBus digital address input. Bit 1.
PMBUS_ADDR2	K1	I	PMBus digital address input. Bit 2.
JTAG			
JTAG_TMS	A10	I	Test mode select with internal pullup
JTAG_TCK	C10	I	Test clock with internal pullup
JTAG_TDO	A11	I/O	Test data out with internal pullup
JTAG_TDI	B10	I/O	Test data in with internal pullup
INPUT POWER, GROUND, AND EXTERNAL REFERENCE PINS			
$\overline{\text{RESET}}$	G10	I	Active-low device reset input. Pull up to V33D.
V33A	D3	I	Analog 3.3-V supply. It should be decoupled from V33D to minimize the electrical noise contained on V33D from affecting the analog functions.
V33D	D7 E6 E8 E9 F10 J7 J9 J10	I	Digital 3.3-V supply for I/O and some logic.

Pin Functions (continued)

PIN		I/O TYPE	DESCRIPTION
NAME	NO.		
BPCap	D6 J1 J6 K13	I	Positive supply for most of the logic function, including the processor core and most peripherals. The voltage on this pin is 1.2 V and is supplied by the on-chip LDO. The BPCap pins should only be connected to each other and an external capacitor as specified in On-Chip Low Drop-Out (LDO) Regulator Characteristics section.
AVSS	C3 E3	I	Analog ground. These are separated from DVSS to minimize the electrical noise contained on V33D from affecting the analog functions.
DVSS	A1 C7 D9 E5 F9 H5 H9 J5 J8 J11	I	Ground reference for logic and I/O pins.
VREFA+	D2	I	(Optional) Positive node of external reference voltage
VREFA-	D1	I	(Optional) Negative node of external reference voltage
UNUSED PINS			
UNUSED-NC	A2 G13 M12 N10		Do not connect. Leave floating/isolated.
UNUSED-DVSS	G12 K11 M10 N13		Tie to DVSS.
UNUSED-V33D	K12		Tie to V33D.

6 Specifications

6.1 Absolute Maximum Ratings

over operating free-air temperature range (unless otherwise noted) ⁽¹⁾

	MIN	MAX	UNIT
Voltage applied at V33D to DVSS	0	4	V
Voltage applied at V33A to AVSS	0	4	V
Input voltage on all I/O pins except PMBUS_CNTRL, PMBALERT#, MARGIN19 and MARGIN20, regardless of whether the device is powered ⁽²⁾⁽³⁾	-0.3	5.5	V
Input voltage on PMBUS_CNTRL, PMBALERT#, MARGIN19 and MARGIN20	-0.3	V33D+0.3	V
Maximum current per output pin	-	25	mA
Maximum junction temperature	-	150	°C
Unpowered storage temperature, T _{stg}	-65	150	°C

- (1) Stresses beyond those listed under *Absolute Maximum Ratings* may cause permanent damage to the device. These are stress ratings only, which do not imply functional operation of the device at these or any other conditions beyond those indicated under *Recommended Operating Conditions*. Exposure to absolute-maximum-rated conditions for extended periods may affect device reliability.
- (2) Applies to static and dynamic signals including overshoot.
- (3) All I/O pins except PMBUS_CNTRL, PMBALERT#, MARGIN19 and MARGIN20 are tolerant to 5-V digital inputs without creating reliability issues, as long as the supply voltage, V33D, is present. There are limitations to how long a 5-V input can be present on any given I/O pin if V33D is not present. Not meeting these conditions will affect reliability of the device and affect the I/O pin characteristics specifications.
- (a) If the voltage applied to an I/O pin is in the high voltage range (5V ± 10%) while V33D is not present, such condition should be allowed for a maximum of 10,000 hours at 27°C or 5,000 hours at 85°C, over the lifetime of the device.
- (b) If the voltage applied to an I/O pin is in the normal voltage range (3.3V ± 10%) while V33D is not present or if the voltage applied is in the high voltage range (5V ± 10%) while V33D is present, there are no constraints on the lifetime of the device.

6.2 ESD Ratings

		VALUE	UNIT
V _(ESD) Electrostatic discharge	Human-body model (HBM), per ANSI/ESDA/JEDEC JS-001 ⁽¹⁾	±2000	V
	Charged-device model (CDM), per JEDEC specification JESD22-C101 ⁽²⁾	±500	

- (1) JEDEC document JEP155 states that 500-V HBM allows safe manufacturing with a standard ESD control process.
- (2) JEDEC document JEP157 states that 250-V CDM allows safe manufacturing with a standard ESD control process.

6.3 Recommended Operating Conditions

over operating free-air temperature range (unless otherwise noted)

		MIN	NOM	MAX	UNIT
V33D supply voltage		3.15	3.3	3.63	V
V33A supply voltage ⁽¹⁾		2.97	3.3	3.63	V
T _A Ambient operating temperature range		-40	-	+85	°C
T _C Case operating temperature range		-40	-	+90	°C
T _J Junction operating temperature range		-40	-	+93	°C

- (1) V33A and V33D should connect to the same supply. Otherwise, V33A must be powered before V33D if sourced from different supplies. There is no restriction on order for powering off.

6.4 Thermal Information

THERMAL METRIC ⁽¹⁾		UCD90240	UNIT
		BGA	
		157 PINS	
R _{θJA}	Junction-to-ambient thermal resistance	41.6	°C/W
R _{θJC(top)}	Junction-to-case (top) thermal resistance	15.8	
R _{θJB}	Junction-to-board thermal resistance	18.9	
Ψ _{JT}	Junction-to-top characterization parameter	0.3	
Ψ _{JB}	Junction-to-board characterization parameter	20.3	
R _{θJC(bot)}	Junction-to-case (bottom) thermal resistance		
T _J	Junction temperature formula	$T_C + (P \times \Psi_{JT})$ $T_{PCB} + (P \times \Psi_{JB})^{(2)}$ $T_A + (P \times \Theta_{JA})^{(3)}$ $T_B + (P \times \Theta_{JB})^{(4)(5)}$	°C

- (1) For more information about traditional and new thermal metrics, see the *IC Package Thermal Metrics* application report, [SPRA953](#).
- (2) T_{PCB} is the temperature of the board acquired by following the steps listed in the EAI/JESD 51-8 standard summarized in the *Semiconductor and IC Package Thermal Metrics Application Report* (literature number [SPRA953](#)).
- (3) Because Θ_{JA} is highly variable and based on factors such as board design, chip/pad size, altitude, and external ambient temperature, it is recommended that equations containing Ψ_{JT} and Ψ_{JB} be used for best results.
- (4) T_B is temperature of the board.
- (5) Θ_{JB} is not a pure reflection of the internal resistance of the package because it includes the resistance of the testing board and environment. It is recommended that equations containing Ψ_{JT} and Ψ_{JB} be used for best results.

6.5 Electrical Characteristics

over operating free-air temperature range (unless otherwise noted)

PARAMETER		TEST CONDITIONS	MIN	TYP	MAX	UNIT
SUPPLY CURRENT						
I _{V33}	Supply current	V33D = V33A = 3.3V	–	31.4	54.9	mA
ON-CHIP LOW DROP-OUT (LDO) REGULATOR						
C _{LDO}	External filter capacitor size for internal power supply ⁽¹⁾		2.5	–	4.0	μF
ESR	Filter capacitor equivalent series resistance		10	–	100	mΩ
ESL	Filter capacitor equivalent series inductance		–	–	0.5	nH
V _{LDO}	LDO output voltage		1.08	1.2	1.32	V
I _{INRUSH}	Inrush current		50	–	250	mA
ANALOG-TO-DIGITAL CONVERTER (ADC)⁽²⁾						
V33A	ADC supply voltage		2.97	3.3	3.63	V
AVSS	ADC ground voltage		–	0	–	V
C _{V33A}	Voltage reference decoupling capacitance between V33A and AVSS		–	1.0/0.01 ⁽³⁾	–	
V _{REFA+}	Positive external voltage reference on VREFA+ pin		2.4	–	3	V
V _{REFA–}	Negative external voltage reference on VREFA– pin		AVSS	AVSS	0.3	V
C _{REF}	Voltage reference decoupling capacitance between VREFA+ and VREFA– (if using external reference)		–	1.0/0.01 ⁽³⁾	–	μF
V _{ADCIN}	Analogue input range, internal reference ⁽⁴⁾		0	–	V33A	V
	Analogue input range, external reference ⁽⁵⁾		VREFA–	–	VREFA+	
I _L	ADC input leakage current		–	–	2.0	μA
R _{ADC}	ADC equivalent input resistance				2.5	kΩ
C _{ADC}	ADC equivalent input capacitance				10	pF
F _{CONV}	ADC conversion rate (on each ADC channel) ⁽²⁾			1		MSPS
N	ADC resolution			12		bits

- (1) The capacitor should be connected as close as possible to pin D6.
- (2) Total of two ADC channels run independently during normal operation.
- (3) Two capacitors in parallel
- (4) Internal reference is connected directly between V33A and AVSS.
- (5) External reference noise level must be under 12bit (–74 dB) of Full Scale input, over input bandwidth, measured at VREFA+ – VREFA–.

Electrical Characteristics (continued)

over operating free-air temperature range (unless otherwise noted)

PARAMETER		TEST CONDITIONS	MIN	TYP	MAX	UNIT
E _T	Total unadjusted error, over full input range when using internal reference ⁽⁶⁾			±10	±30	LSB
	Total unadjusted error, over full input range when using external reference ⁽⁶⁾			±2.5	±4.0	
DIGITAL INPUTS AND OUTPUTS (GPIO, LOGIC GPO, EN, AND MARGIN PINS)						
V _{IH}	I/O high-level input voltage ⁽⁷⁾		0.65×V _{33D}	–	5.5V	V
V _{IL}	I/O low-level input voltage		0	–	0.35×V _{33D}	V
V _{HYS}	I/O input hysteresis		0.2	–	–	V
V _{OH}	I/O high-level output voltage		2.4	–	–	V
V _{OL}	I/O low-level output voltage		–	–	0.4	V
I _{OH}	High-level source current, V _{OH} = 2.4V ⁽⁸⁾		4.0	–	–	mA
I _{OL}	Low-level sink current, V _{OL} = 0.4V ⁽⁸⁾		4.0	–	–	mA
RESET AND BROWNOUT						
V _{33DSlew}	Minimum V _{33D} slew rate between 2.8V and 3.2V		0.1	–	–	V/ms
V _{RESET}	Supply voltage at which device comes out of reset		2.85	3.00	3.15	V
V _{BOR}	Supply voltage at which device enters brownout		2.93	3.02	3.11	V
V _{SHDN}	Supply voltage at which device shuts down		2.70	2.78	2.87	V
t _{RESET}	Minimum low-pulse width needed at $\overline{\text{RESET}}$ pin		–	250	–	ns
t _{IRT}	Internal Reset Time ⁽⁹⁾		–	9	11.5	ms

(6) Total Unadjusted Error is the maximum error at any one code versus the ideal ADC curve. It includes offset error, gain error and INL at any given ADC code.

(7) PMBUS_CNTRL, PMBALERT#, MARGIN19 and MARGIN20 pins have V_{33D}+0.3V as maximum input voltage rating.

(8) I_O specifications reflect the maximum current where the corresponding output voltage meets the V_{OH}/V_{OL} thresholds.

(9) If power-loss or brown-out event occurs during an EEPROM program or erase operation, and EEPROM needs to be repaired (which is a rare case), the Internal Reset Time may be longer.

6.6 Nonvolatile Memory Characteristics

over operating free-air temperature range (unless otherwise noted)

PARAMETER		MIN	TYP	MAX	UNIT
CONFIGURATION FLASH MEMORY					
PE _{CYC}	Number of program/erase cycles before failure	100 000	–	–	Cycles
T _{RET}	Data retention, -40°C to +85°C	20	–	–	Years
FAULT AND EVENT LOGGING EEPROM					
EPE _{CYC}	Number of mass program/erase cycles of a single word before failure	500 000	–	–	Cycles
ET _{RET}	Data retention, -40°C to +85°C	20	–	–	Years

6.7 I²C/PMBUS Timing Requirements

PARAMETER		MIN	TYP	MAX	UNIT
I1	t _(HD:STA) Start condition hold time	450	–	–	ns
I2	t _(LOW) Clock Low period ⁽¹⁾	450	–	–	ns
I3	t _r Clock/Data rise time ⁽²⁾	–	–	See ⁽²⁾	ns
I4	t _(HD:DAT) Data hold time	–	25	–	ns
I5	t _f Clock/Data fall time ⁽³⁾	–	112.5	125	ns
I6	t _(HIGH) Clock High time	300	–	–	ns
I7	t _(SU:DAT) Data setup time	225	–	–	ns
I8	t _(SU:STA) Start condition setup time (Repeated start only)	450	–	–	ns
I9	t _(SU:STO) Stop condition setup time	300	–	–	ns
I10	t _(DV) Data Valid	–	25	–	ns

- (1) PMBus host must support clock stretching per PMBus Power System Management Protocol Specification Part I General Requirements, Transport And Electrical Interface, Revision 1.2, Section 5.2.6.
- (2) Because I2CSCL and I2CSDA operate as open-drain-type signals, which the controller can only actively drive Low, the time I2CSCL or I2CSDA takes to reach a high level depends on external signal capacitance and pullup resistor values.
- (3) Specified at a nominal 50 pF load.

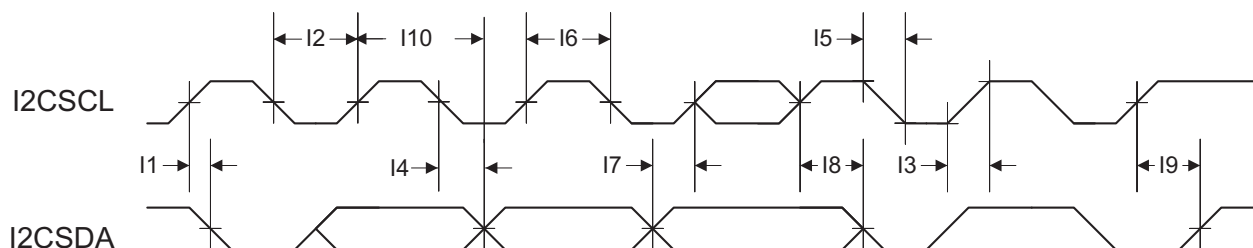

7 Detailed Description

7.1 Device Overview

Electronic systems that include CPU, DSP, microcontroller, FPGA, ASIC, etc. can have multiple voltage rails and require certain power on/off sequences in order to function correctly. The UCD90240 can control up to 24 voltage rails and ensure correct power sequences during normal condition and fault conditions.

In addition to sequencing, UCD90240 can continuously monitor rail voltages, currents, temperatures, fault conditions, and report the system health information to upper computers through PMBus, improving systems' long term reliability.

Also, UCD90240 can protect electronic systems by responding to power system faults. The fault responses are conveniently configured by users through Fusion GUI. Fault events are stored in on-chip nonvolatile flash memory in order to assist failure analysis. A Black Box Fault Log feature stores comprehensive system statuses at the moment when the first fault occurs. With this feature, failure analysis can be more effective.

System reliability can be improved through four-corner testing during system verification. During four-corner testing, each voltage rail is required to operate at the minimum and maximum output voltages, commonly known as margining. UCD90240 can perform accurate closed-loop margining for up to 24 voltage rails. During normal operation, UCD90240 can also actively trim DC output voltages using the same margining circuitry. This feature allows tuning rail voltages to an optimal level.

UCD90240 supports both PMBus- and pin-based control environments. UCD90240 functions as a PMBus slave. It can communicate with upper computers with PMBus commands, and control voltage rails accordingly. In addition to rail enable (EN) pins, up to 24 GPIO pins can be configured as GPOs and directly controlled by PMBus commands. Also, UCD90240 can be controlled by up to 24 GPIO configured GPI pins. The GPIs can be used as fault inputs which can shut down rails. The GPIs can be also used as Boolean logic input to control the 12 Logic GPO outputs. Each of the 12 dedicated Logic GPO pins has a flexible Boolean logic builder. Input signals of the Boolean logic builder can include GPIs, other GPOs, and selectable system flags such as POWER_GOOD, faults, warnings, etc. A simple state machine is also available for each Logic GPO pin.

UCD90240 provides additional features such as cascading, pin-selected states, system watchdog, system reset, runtime clock, peak value log, reset counter, and so on. Cascading feature offers convenient ways to cascade up to four UCD90240 devices and manage up to 96 voltage rails via one Sync Clock pin connection. Pin-selected states feature allows users to define up to 8 rail states. These states can implement system low-power modes as set out in the Advanced Configuration and Power Interface (ACPI) specification. Other UCD90240 features will be introduced in the following sections of this data sheet.

7.2 Functional Block Diagram

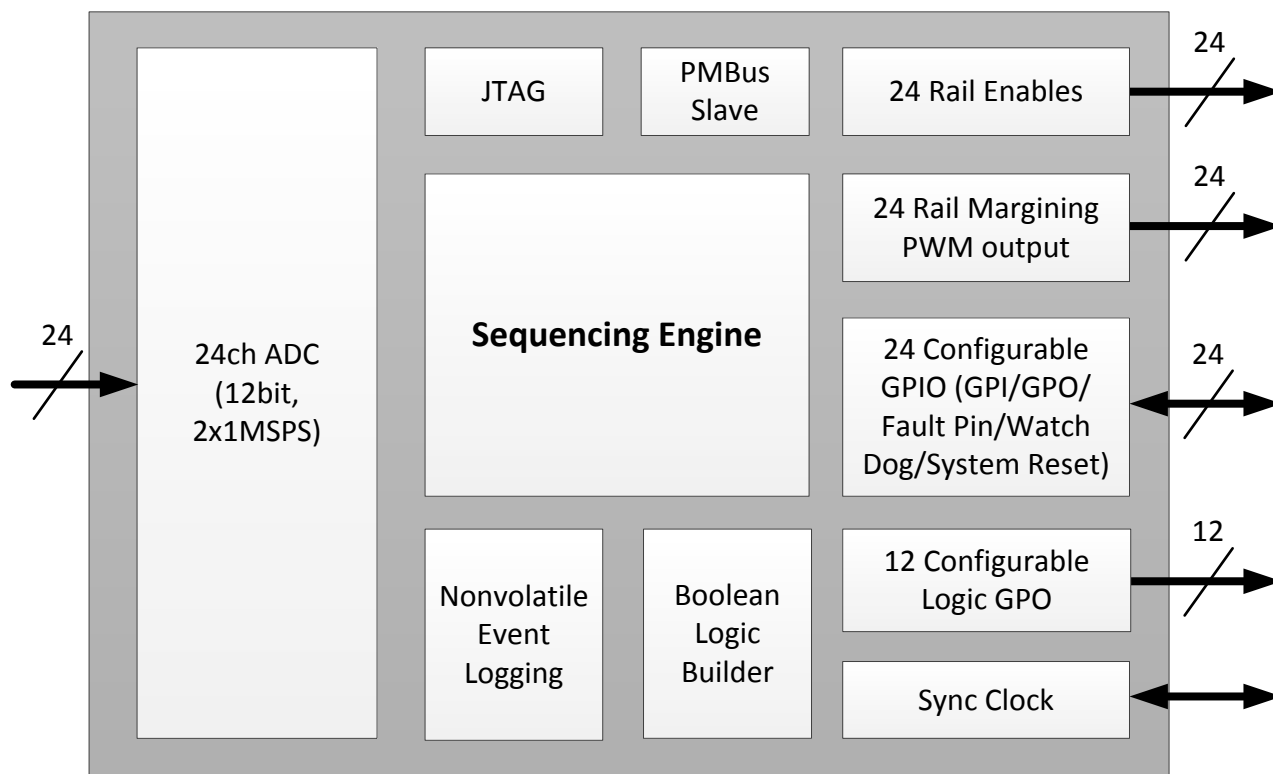

7.3 Feature Description

7.3.1 TI Fusion GUI

The Texas Instruments Fusion Digital Power Designer is provided for device configuration. This PC-based graphical user interface (GUI) offers an intuitive I2C/PMBus interface to the device. It allows the design engineer to configure the system operating parameters for the application without directly using PMBus commands, store the configuration to on-chip nonvolatile memory, and observe system status (voltage, current, temperature, faults, etc.). Fusion Digital Power Designer is referenced throughout the data sheet as Fusion GUI and many sections include screenshots. The Fusion GUI can be downloaded from www.ti.com. After the device has been configured, UCD90240 can perform all designed functions independently without Fusion GUI.

7.3.2 PMBUS Interface

The PMBus is a serial interface specifically designed to support power management. It is based on the SMBus interface that is built on the I2C physical specification. The UCD90240 supports revision 1.2 of the PMBus standard. Wherever possible, standard PMBus commands are used to support the function of the device. For unique features of the UCD90240, MFR_SPECIFIC commands are defined to configure or activate those features. These commands are defined in the UCD90xxx Sequencer and System Health Controller PMBUS Command Reference (SLVU352). The most current UCD90xxx PMBus™ Command Reference can be found within the TI Fusion Digital Power Designer software via the Help Menu (Help, Documentation and Help Center, Sequencers tab, Documentation section).

This document makes frequent mention of the PMBus specification. Specifically, this document is *PMBus Power System Management Protocol Specification Part II – Command Language*, Revision 1.2, dated 6 September 2010. The specification is published by the Power Management Bus Implementers Forum and is available from www.pmbus.org.

The UCD90240 is PMBus compliant, in accordance with the *Compliance* section of the PMBus specification. The firmware is also compliant with the SMBus 1.1 specification, including support for the SMBus ALERT function. The hardware can support either 100-kHz or 400-kHz PMBus operation.

Feature Description (continued)

7.3.3 Rail Setup

Power rails are defined under the Pin Assignment tab, as shown in [Figure 1](#). Click corresponding buttons to add or delete a rail. After a rail is added, MON, EN, and MARGIN pins can be assigned to the rail. UCD90240 has 24 MON pins, 24 EN pin, and 24 MARGIN pins, thus can support up to 24 rails.

Rails - Monitors & Enables							5 of 24 Assigned
	Rail Name	Voltage	Temperature	Current	Enable	Trim/Margin PWM	Actions
Rail #1	<input type="text" value="Rail #1"/>	Pin E1 MON_01	<Click to Assign>	<Click to Assign>	Pin M9 EN_01	Pin J13 PWM_01	Delete Configure
Rail #2	<input type="text" value="Rail #2"/>	Pin E2 MON_02	<Click to Assign>	<Click to Assign>	Pin N9 EN_02	Pin L5 PWM_02	Delete Configure
Rail #3	<input type="text" value="Rail #3"/>	Pin F2 MON_03	<Click to Assign>	<Click to Assign>	Pin L10 EN_03	Pin D8 PWM_03	Delete Configure
Rail #4	<input type="text" value="Rail #4"/>	Pin F1 MON_04	<Click to Assign>	<Click to Assign>	Pin K10 EN_04	Pin K6 PWM_04	Delete Configure
Rail #5	<input type="text" value="Rail #5"/>	Pin B3 MON_05	<Click to Assign>	<Click to Assign>	Pin L9 EN_05	Pin D4 PWM_05	Delete Configure

[Add Rail](#)

Figure 1. Fusion GUI Rail Setup Window (Configure ► Pin Assignment tab).

7.3.4 Rail Monitoring Configuration

Once rails are set up in the Pin Assignment tab, they are visible under the Vout Config tab, as shown in [Figure 2](#). The initial voltage values are 0.

Select Rail to Edit						Review in Larger Window <input checked="" type="checkbox"/>
Rail #	Rail Name	Vout	On Delay	Off Delay	Dependencies (Direc...	
1	Rail #1	0.000	0.0	0.0	Vin On/Off	
2	Rail #2	0.000	0.0	0.0	Vin On/Off	
3	Rail #3	0.000	0.0	0.0	Vin On/Off	
4	Rail #4	0.000	0.0	0.0	Vin On/Off	
5	Rail #5	0.000	0.0	0.0	Vin On/Off	

Figure 2. Rail Selection Window (Configure ► Vout Config tab).

Voltage monitoring parameters of the selected rail can be configured under the same Vout Config tab. The configuration window is shown in [Figure 3](#).

Feature Description (continued)

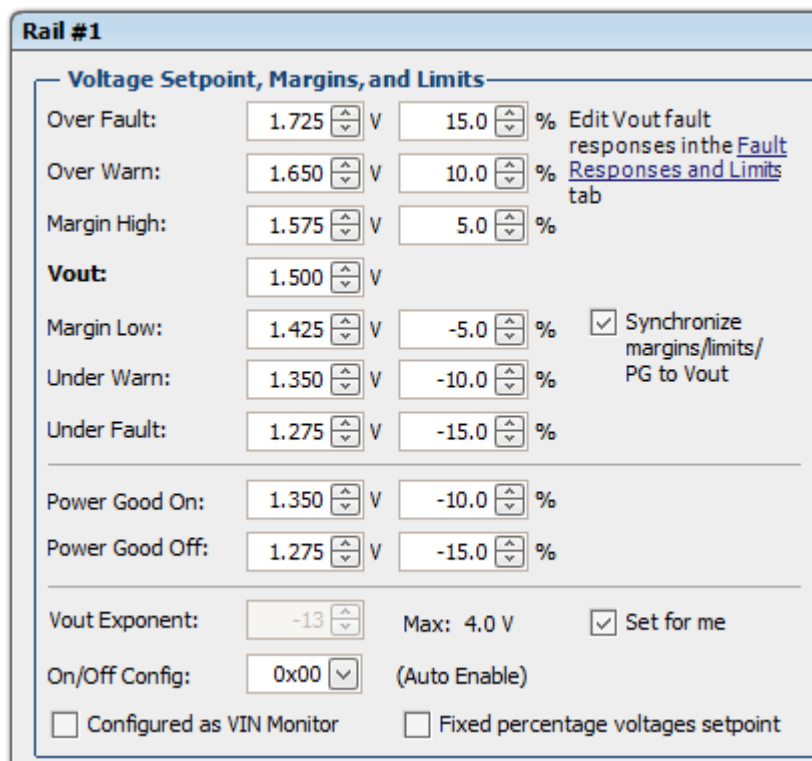

Figure 3. Rail Voltage Configuration Window (Configure ► Vout Config tab).

If a MON pin is assigned in Figure 1 to monitor a rail's voltage, a warning/fault event will occur when the monitored rail voltage exceeds the voltage window defined by the *Over and Under Warn/Fault* thresholds. When a fault is detected, UCD90240 will respond with user-defined actions. More details will be discussed in the FAULT RESPONSES CONFIGURATION section.

Vout Exponent defines the voltage value resolution according to PMBus linear data format. Fusion GUI can automatically select optimal Vout Exponent value to cover the required voltage range with the finest possible resolution. For more information regarding PMBus linear data format, refer to PMBus specification mentioned at the beginning of this section.

On/Off Config defines the turnon and turnoff command of a rail:

- None (Auto enable). Rail always seeks to turn on.
- CONTROL Pin Only. Rail seeks to turn on and turn off according to PMBus CONTROL line.
- OPERATION Only. Rail seeks to turn on and turn off according to PMBus OPERATION command.
- Both CONTROL pin and OPERATION. Rail seeks to turn on when CONTROL pin is asserted, AND PMBus OPERATION command sets the rail to On. Rail seeks to turn off when OPERATION command sets the rail to Off, OR when CONTROL line is deasserted, or both.

After a turn on or turn off command is received, a rail examines a series of conditions before asserting or deasserting its EN pin. Conditions include *Rail Sequence On/Off Dependency*, *GPI Sequence On/Off Dependency*, *Turn-On/Off Delay*, and so on. They will be discussed in the RAIL SEQUENCE CONFIGURATION section.

Fixed percentage voltages setpoint, when checked, configures a rail into AVS mode (Adaptive Voltage Scaling Technology). The VOUT setpoint may be dynamically set by PMBus during operation in order to achieve energy saving. The warn and fault voltage thresholds of the rail will maintain fixed ratios with respect to the VOUT setpoint. Due to the fact that the power supply and UCD90240 may not change Vout setpoint simultaneously or with the same slew rate, UCD90240 will take the following steps to avoid false-triggering warn/fault. If the new VOUT setpoint is higher than the current VOUT setpoint, the OV warn/fault thresholds will be immediately set to

Feature Description (continued)

their respective new levels; other thresholds will initially stay unchanged, and then increase by 20-mV step size every 400 μ s until the new levels are reached. If the new VOUT setpoint is lower than the current VOUT setpoint, the UV warn/fault and Power Good On/Off thresholds will be immediately set to their respective new levels; other thresholds will initially stay unchanged, and then decrease by 20-mV step size every 400 μ s until the new levels are reached. The thresholds adjustment scheme in AVS mode is summarized in [Table 1](#).

Table 1. Thresholds Adjustment Scheme in AVS Mode

	Immediate Update	Gradual adjustment towards new levels with 20mV step size and 400 μ s step interval
New VOUT setpoint > Current VOUT setpoint	OV Fault/Warn	UV Fault/Warn, Margin High/Low, Power Good On/Off
New VOUT setpoint < Current VOUT setpoint	UV Fault/Warn, Power Good On/Off	OV Fault/Warn, Margin High/Low

Current and temperature monitoring parameters of the selected rail can be configured under the Fault Responses and Limits tab. First select a rail in the top-right corner of the FUSION GUI, and then edit the current and temperature monitoring parameters as shown in [Figure 4](#).

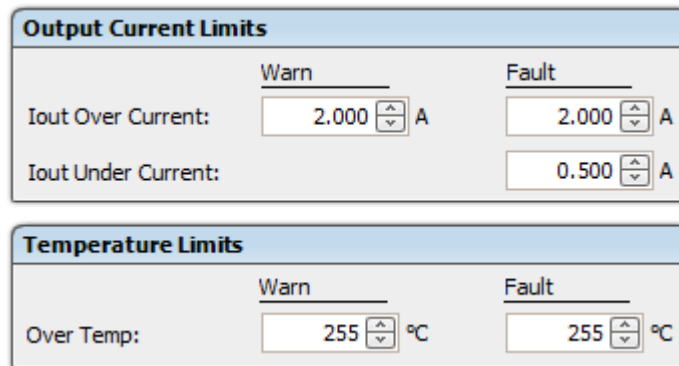

Figure 4. Current and Temperature Limits Configuration Window (Configure ► Fault Responses and Limits tab)

Each rail has a *Power Good* status which is determined by the following rules:

- If rail voltage is monitored by a MON pin, the *Power Good* status is solely determined by *Power Good On/Off* thresholds as shown in [Figure 3](#). A rail is given *Power Good* status if its rail voltage is above the *Power Good On* threshold. Otherwise, the rail is given *Not Power Good* status if the rail voltage is below the *Power Good Off* threshold. The rail remains in the current status if its voltage is neither above *Power Good On* nor below *Power Good Off* thresholds.
- If rail voltage is not monitored by a MON pin, the *Power Good* status is determined by the turnon and turnoff eligibility of the rail. A rail is immediately given *Power Good* status when the rail meets all the turnon conditions set by the user, such as *On/Off Config*, dependencies and delays. Similarly, a rail is immediately given *Not Power Good* status when the rail meets all the turnoff conditions set by the user. The behavior is the same regardless whether a physical EN pin is assigned to the rail.

The *Power Good* status is not affected by any warnings and faults unless the fault response is to turn off the rail. UV fault/warn is ignored when a rail is off. UV fault/warn is also ignored during start up until the rail enters *Power Good* status for the first time. This mechanism avoids false-triggering UV fault/warn when the rail voltage is expected to be below UV thresholds.

A *Graceful Shutdown* feature is enabled by checking the *Configured as VIN Monitor* checkbox. When enabled, the rail is configured to monitor VIN. When VIN drops below *Power Good Off* threshold, all other rails' UV faults/warns will be ignored.

7.3.5 GPI Configuration

UCD90240 has 24 GPIO pins. All of them can be configured as GPI. The GPI configuration window is under the Pin Assignment tab. An example is shown in [Figure 5](#).

GPIs - General Purpose Inputs				5 of 24 Assigned
GPI Name	Pin	Polarity	Special Behavior	Actions
GPI #1	Pin L4 GPIO_01	Active High	---	Delete Configure
GPI #2	Pin N1 GPIO_02	Active High	---	Delete Configure
GPI #3	Pin M4 GPIO_03	Active High	---	Delete Configure
GPI #4	Pin N2 GPIO_04	Active High	---	Delete Configure
GPI #5	Pin G3 GPIO_05	Active High	---	Delete Configure

[Add GPI](#)

Figure 5. GPI Configuration Window (Configure ► Pin Assignment tab).

The polarity of GPI pins can be configured to be Active High or Active Low. Each GPI can be used as a source of sequence dependency, which will be discussed in the RAIL SEQUENCE CONFIGURATION section. The GPI pins can be also used for cascading function, which will be discussed in CASCADING MULTIPLE DEVICES section. The first defined three GPIs regardless of their main purpose will be used for the Pin Selected States function, which will be discussed in PIN SELECTED STATES section.

In addition to above functions, four special behaviors can be assigned to each GPI pin in the dropdown window shown in [Figure 6](#):

- **GPI Fault** – The deassertion of this pin is treated as a fault, which can trigger shut-down actions for any voltage rails. More details are discussed in the [Fault Responses Configuration](#) section.
- **Latched Statuses Clear Source** – this pin can be used to clear latched-type statuses (`_LATCH`). More details are discussed in [GPO Configuration](#) section.
- **Input Source for Margin Enable** – When this pin is asserted, all rails with margining enabled will be put in a margined state (low or high). No more than one GPI can have this special behavior.
- **Input Source for Margin Low/Not-High** – When this pin is asserted, all margined rails will be set to Margin Low as long as the Margin Enable is asserted. When this pin is deasserted the rails will be set to Margin High as long as the Margin Enable is asserted. No more than one GPI can have this special behavior.

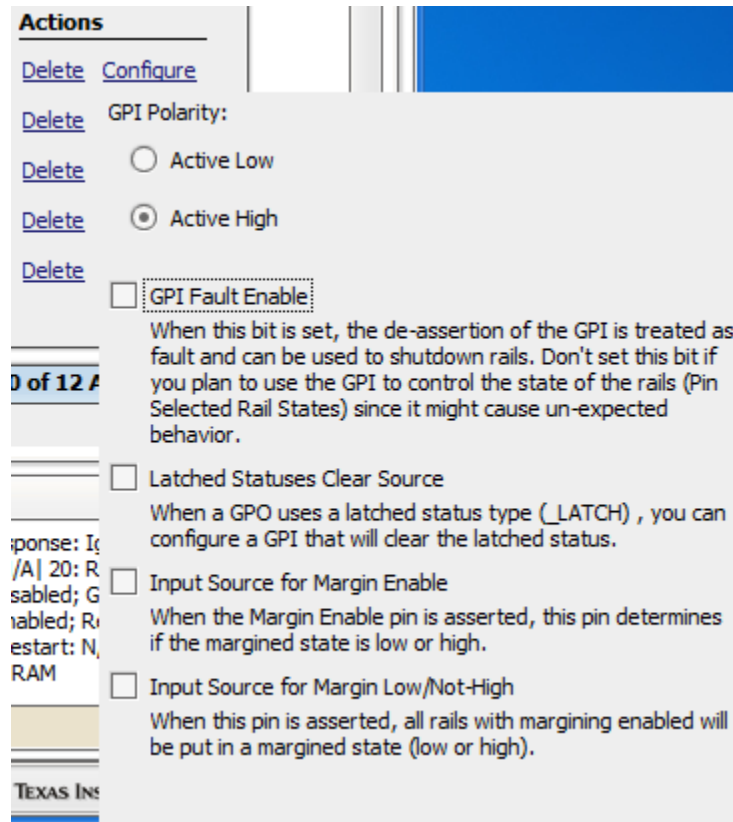

Figure 6. GPI Configuration Dropdown Window (Configure ► Pin Assignment tab).

7.3.6 Rail Sequence Configuration

Rail sequences can be configured in the Vout Config tab. First select a rail in the top-right corner of the FUSION GUI, and then edit the rail sequence as shown in [Figure 7](#).

<p>Turn On Timing</p> <p>Turn On Delay: <input type="text" value="0.0"/> ms</p> <p>Max Turn On: <input type="text" value="∞"/> ms</p> <p><input checked="" type="checkbox"/> No limit</p>	<p>Turn Off Timing</p> <p>Turn Off Delay: <input type="text" value="0.0"/> ms</p> <p>Max Turn Off: <input type="text" value="∞"/> ms</p> <p><input checked="" type="checkbox"/> No limit</p>						
<p>Rail Seq On Dependencies</p> <p><input type="checkbox"/> Rail #1 <input type="checkbox"/> Rail #2 <input type="checkbox"/> Rail #3</p> <p><input type="checkbox"/> Rail #4 <input type="checkbox"/> Rail #5</p> <p>Check All Uncheck All</p>	<p>GPI Seq On Dependencies</p> <p><input type="checkbox"/> GPI #1 (L4 GPIO_01)</p> <p><input type="checkbox"/> GPI #2 (N1 GPIO_02)</p> <p><input type="checkbox"/> GPI #3 (M4 GPIO_03)</p> <p><input type="checkbox"/> GPI #4 (N2 GPIO_04)</p> <p><input type="checkbox"/> GPI #5 (G3 GPIO_05)</p> <p>Check All Uncheck All</p>						
<p>Rail Seq Off Dependencies</p> <p><input type="checkbox"/> Rail #1 <input type="checkbox"/> Rail #2 <input type="checkbox"/> Rail #3</p> <p><input type="checkbox"/> Rail #4 <input type="checkbox"/> Rail #5</p> <p>Check All Uncheck All</p>	<p>GPI Seq Off Dependencies</p> <p><input type="checkbox"/> GPI #1 (L4 GPIO_01)</p> <p><input type="checkbox"/> GPI #2 (N1 GPIO_02)</p> <p><input type="checkbox"/> GPI #3 (M4 GPIO_03)</p> <p><input type="checkbox"/> GPI #4 (N2 GPIO_04)</p> <p><input type="checkbox"/> GPI #5 (G3 GPIO_05)</p> <p>Check All Uncheck All</p>						
<p>Sequencing Timeout</p> <table border="0"> <tr> <td>Timeout Period:</td> <td>Timeout Action:</td> </tr> <tr> <td>On Sequence: <input type="text" value="0"/> msec</td> <td>On: <input type="text" value="Wait Indefinitely"/></td> </tr> <tr> <td>Off Sequence: <input type="text" value="0"/> msec</td> <td>Off: <input type="text" value="Wait Indefinitely"/></td> </tr> </table>		Timeout Period:	Timeout Action:	On Sequence: <input type="text" value="0"/> msec	On: <input type="text" value="Wait Indefinitely"/>	Off Sequence: <input type="text" value="0"/> msec	Off: <input type="text" value="Wait Indefinitely"/>
Timeout Period:	Timeout Action:						
On Sequence: <input type="text" value="0"/> msec	On: <input type="text" value="Wait Indefinitely"/>						
Off Sequence: <input type="text" value="0"/> msec	Off: <input type="text" value="Wait Indefinitely"/>						
<p>Fault Shutdown Slaves</p> <p>If Rail #1 shuts down due to a fault, turn off these rails as well:</p> <p><input type="checkbox"/> Rail #1 <input type="checkbox"/> Rail #2 <input type="checkbox"/> Rail #3 <input type="checkbox"/> Rail #4 <input type="checkbox"/> Rail #5</p> <p>Check All Uncheck All</p>							

Figure 7. Rail Sequence Configuration Window (Configure ► Vout Config tab).

When a rail receives a turnon or turnoff command as defined in *On/Off Config*, it will check its dependency conditions. When all dependencies are fulfilled, the rail will then wait for a *Turn On/Off Delay* time, and then assert/deassert the EN pin.

A *Rail Sequence On Dependency* is fulfilled when the rail is in *Power Good* status. A *Rail Sequence Off Dependency* is fulfilled when the rail is in *Not Power Good* status. A *GPI Sequence On* dependency is fulfilled when the GPI pin is asserted. A *GPI Sequence Off* dependency is fulfilled when the GPI pin is deasserted.

After the EN pin of a rail is asserted, if the rail voltage does not rise above *Power Good On* threshold within *Max Turn On* time, a *Time On Max* fault will occur. Similarly, after the EN pin of a rail is deasserted, if the rail voltage does not fall below 12.5% nominal *Vout* within *Max Turn Off* time, a *Time Off Max* warn will occur.

Each rail can have *Fault Shutdown Slaves*. When a rail is shut down as a result of a fault, its slave rails will also shut down. The delays and dependencies of the slave rails will still be observed during the shutdown process. Fault Shutdown Slaves cannot cascade. In other words, if a rail is shut down as a slave, it will not shut down its own slave rails.

Each rail can set *Sequencing On/Off Timeout* periods. The timeout periods start to count when a rail receives a turnon or turnoff command as defined in *On/Off Config*. When the *Sequencing On/Off Timeout* period elapsed, the rail will execute one of three actions including:

- Wait Indefinitely
- Enable/Disable Rail
- Re-sequence (Sequencing On only)

Re-sequence is a series of actions that shut down a rail and its Fault Shutdown Slaves, and then re-enable the rails according to sequence-on delay times and dependencies. The Re-sequencing parameters can be configured in the Other Config tab, as shown in [Figure 8](#).

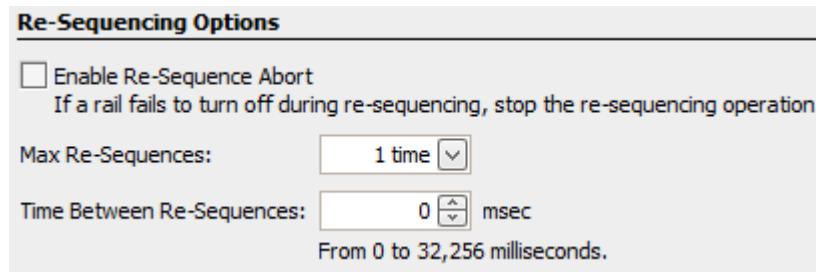

Re-Sequencing Options

Enable Re-Sequence Abort
If a rail fails to turn off during re-sequencing, stop the re-sequencing operation.

Max Re-Sequences: 1 time

Time Between Re-Sequences: 0 msec
From 0 to 32,256 milliseconds.

Figure 8. Re-Sequencing Options (Configure ► Other Config tab).

Re-sequencing can be repeated for 1~4 times or unlimited times. The *Time Between Re-Sequences* period will start to count when all the relevant rails are given *Not Power Good* statuses. When the time period elapses, a Re-sequence will start. The *Enable Re-Sequence Abort* checkbox, when checked, will abort Re-sequence if any relevant rail triggers a *Max Turn Off* warning. However, the *Max Turn Off* warning will not stop an ongoing Re-sequence.

When Rail Sequence configurations are completed, simulated sequence timing will be shown in the *Vout Config* tab. It demonstrates the dependencies among the rails. An example is shown in [Figure 9](#). The power-on/off slew rates of the rail in [Figure 9](#) are for demonstration purpose only.

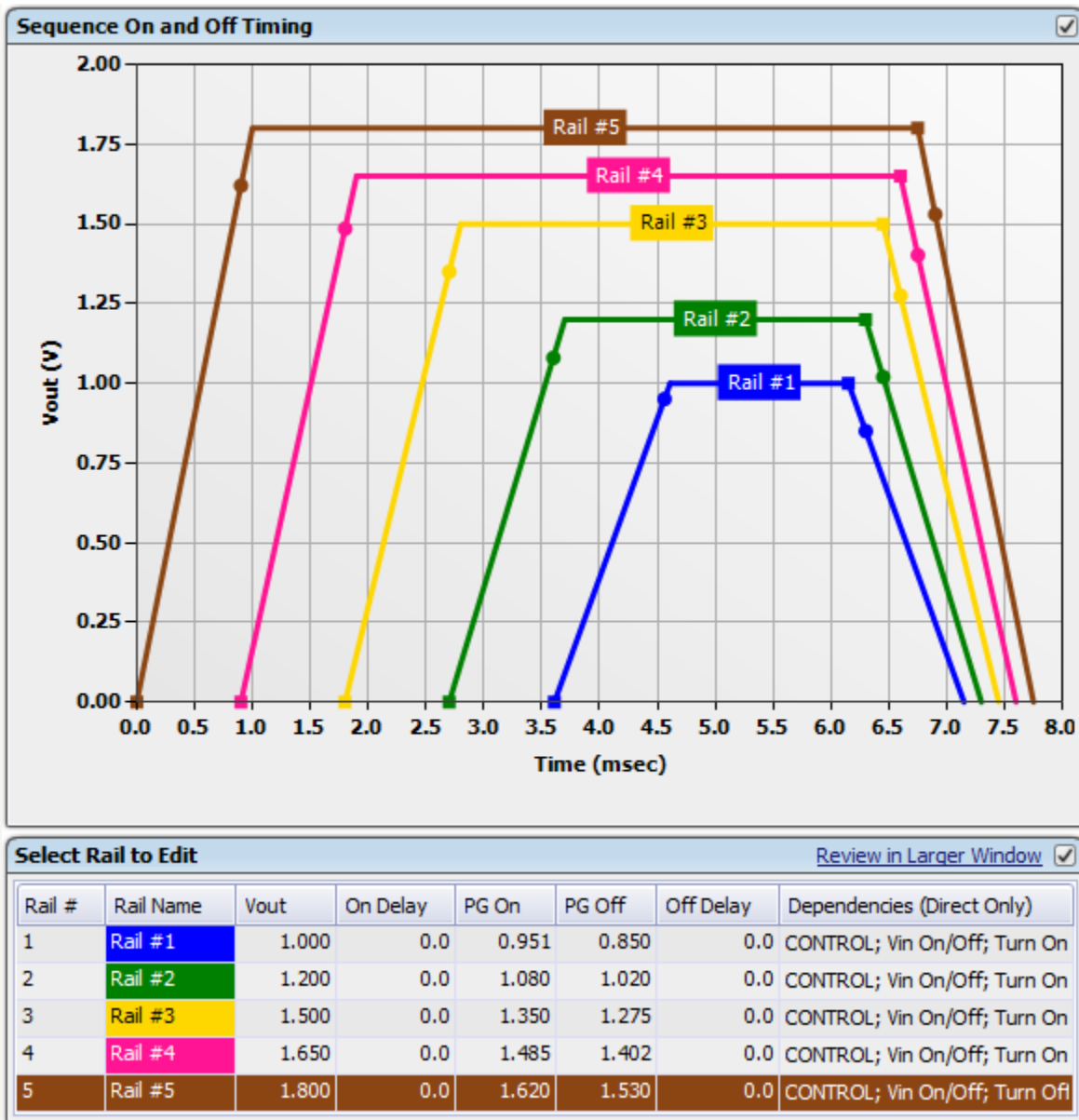

Figure 9. Simulated Sequence Timing Window (Configure ► Vout Config Config tab)

7.3.7 Fault Responses Configuration

In the previous sections, various fault/warning thresholds have been configured to monitor voltage, current, temperature, and turnon and turnoff time. When a fault threshold is reached, a fault event will occur. UCD90240 does three actions in response of a fault event: (1) Assert PMBus ALERT# line, (2) Log the fault event into nonvolatile memory (data flash), (3) Execute fault responses defined by users. The Fault Responses can be configured under the Fault Responses and Limits tab. An example configuration window is shown in Figure 10.

Fault Responses

Time between restarts: msec

Voltage fault max glitch time: msec

Non-voltage fault max glitch time: msec

Fault	Glitch Filter	Re-Sequence	Response	Restart	
Vout Over Voltage	0.4 msec	Yes	Shut down immediately	Restart up to 5 times	Edit
Vout Under Voltage	Disabled	No	Ignore	N/A	Edit
Iout Over Current	100 msec	Yes	Shut down with delay	Restart continuously	Edit
Iout Under Current	Disabled	No	Ignore	N/A	Edit
Over Temp	100 msec	No	Shut down with delay	Do not restart	Edit
Time On Max	Disabled	No	Ignore	N/A	Edit

**Figure 10. Fault Responses Configuration Window
(Configure ► Fault Responses and Limits tab).**

A programmable glitch filter can be enabled or disabled for each type of fault. If a fault is still present after the glitch filter time is expired, UCD90240 will take one of the three selectable actions:

- Log the fault and take no further action;
- Shut down the rail immediately;
- Shut down the rail with *Turn Off Delay*.

After shutting down the rail, UCD90240 will do one of the three selectable actions:

- Do not restart the rail until the fault is cleared;
- Restart the rail; if unsuccessful, retry up to a user-defined times (maximum 14) and then stay off until the fault is cleared;
- Restart the rail; if unsuccessful, retry for an unlimited number of times unless the rail is commanded off by a signal defined in *On/Off Config*.

After the rail exhausts the restart attempts, Re-sequence can be initiated. Discussion on Re-sequence is in the RAIL SEQUENCE CONFIGURATION section.

Voltage, current, and temperature monitoring are based on results from the 12-bit ADC. All the voltage monitoring ADC channels are monitored every 400 μ s for up to 24 channels. Current monitoring ADC channels are monitored at 200 μ s per channel. Temperature monitoring ADC channels are monitored at \sim 4.17ms per channel. The ADC results are compared with the programmed thresholds. The time to respond to an individual event is determined by when the event occurs within the ADC conversion cycle and the configured fault responses (glitch filters, time delays, etc.).

GPI pins can also trigger faults if the GPI Fault Enable checkbox in [Figure 6](#) is checked. The GPI Fault Responses options are the same as the Fault Responses discussed above. An example configuration window is shown in [Figure 11](#).

GPI Fault Responses

Time between restarts: msec

Max glitch time: msec

Fault	Glitch Filter	Resequence	Response	Restart	
GPI #01	0.3 msec	Yes	Shut down immediately	Restart up to 1 times	Edit
GPI #02	Disabled	No	Ignore	N/A	Edit
GPI #03	Disabled	No	Ignore	N/A	Edit
GPI #04	Disabled	No	Ignore	N/A	Edit
GPI #05	Disabled	No	Ignore	N/A	Edit
GPI #06 (Unassigned)	Disabled	No	Ignore	N/A	Edit
GPI #07 (Unassigned)	Disabled	No	Ignore	N/A	Edit

Figure 11. GPI Fault Responses Configuration Window (Configure ► Fault Responses and Limits tab).

7.3.8 GPO Configuration

7.3.8.1 Command Controlled GPO

UCD90240 has 24 GPIO pins, all of which can be configured as Command Controlled GPOs. These GPOs are controlled by PMBus commands (GPIO_SELECT and GPIO_CONFIG) and can be used to control LEDs, enable switches, etc. Details on controlling a GPO using PMBus commands can be found in the *UCD90xxx Sequencer and System Health Controller PMBUS Command Reference (SLVU352)*. The configuration window of Command Controlled GPO is under Pin Assignment tab. An example configuration window is shown in Figure 12.

Command Controlled GPOs - General Purpose Outputs with Fixed State 5 of 24 Assigned

GPO Name	Pin	State	Actions
<input type="text" value="Command GPO #1"/>	Pin D10 GPIO 06	<input checked="" type="radio"/> Low (0) <input type="radio"/> High (1) <input type="radio"/> Hi-Z	Delete
<input type="text" value="Command GPO #2"/>	Pin L11 GPIO 07	<input checked="" type="radio"/> Low (0) <input type="radio"/> High (1) <input type="radio"/> Hi-Z	Delete
<input type="text" value="Command GPO #3"/>	Pin N12 GPIO 08	<input checked="" type="radio"/> Low (0) <input type="radio"/> High (1) <input type="radio"/> Hi-Z	Delete
<input type="text" value="Command GPO #4"/>	Pin N11 GPIO 09	<input checked="" type="radio"/> Low (0) <input type="radio"/> High (1) <input type="radio"/> Hi-Z	Delete
<input type="text" value="Command GPO #5"/>	Pin M11 GPIO 10	<input checked="" type="radio"/> Low (0) <input type="radio"/> High (1) <input type="radio"/> Hi-Z	Delete

[Add Command Controlled GPO](#)

Figure 12. Command Controlled GPO Configuration Window (Configure ► Pin Assignments tab).

7.3.8.2 Logic GPO

UCD90240 also has 12 dedicated Logic GPO (LGPO) pins. The configuration window is under Pin Assignment tab, as shown in Figure 13.

Logic Controlled GPOs - General Purpose Outputs with Programmable State Logic					5 of 12 Assigned
GPO Name	Pin	Polarity	Mode	Configuration Summary	Actions
<input type="checkbox"/> Logic GPO #1	Pin C9 GPO_01	Active High	Actively Driven	Delay=0 ms * <No Logic>	Delete Configure
<input type="checkbox"/> Logic GPO #2	Pin B9 GPO_02	Active High	Actively Driven	Delay=0 ms * <No Logic>	Delete Configure
<input type="checkbox"/> Logic GPO #3	Pin A9 GPO_03	Active High	Actively Driven	Delay=0 ms * <No Logic>	Delete Configure
<input type="checkbox"/> Logic GPO #4	Pin C8 GPO_04	Active High	Actively Driven	Delay=0 ms * <No Logic>	Delete Configure
<input type="checkbox"/> Logic GPO #5	Pin D5 GPO_05	Active High	Actively Driven	Delay=0 ms * <No Logic>	Delete Configure

[Add Logic Controlled GPO](#) [Move Selected Pins Up](#) [Move Selected Pins Down](#)

Figure 13. Logic GPO Configuration Window (Configure ► Pin Assignments tab).

Each LGPO is controlled by an internal Boolean logic builder. The configuration interface of the Boolean logic builder is shown in Figure 14. As shown, each Boolean logic builder has a top-level logic gate, which can be configured as AND, OR, or NOR gate with optional time delay. The inputs of the top-level logic gate are two AND paths. Each AND path can select a variety of inputs including GPI states, LGPO states, and rail statuses, as shown in Figure 15. The selectable rail statuses are summarized in Table 2. In Table 2, *_LATCH* type statuses stay asserted until cleared by a MFR PMBus command or by a specially configured GPI pin shown in Figure 6. See the *UCD90xxx Sequencer and System Health Controller PMBUS Command Reference (SLVU352)* for complete definitions of rail-status types.

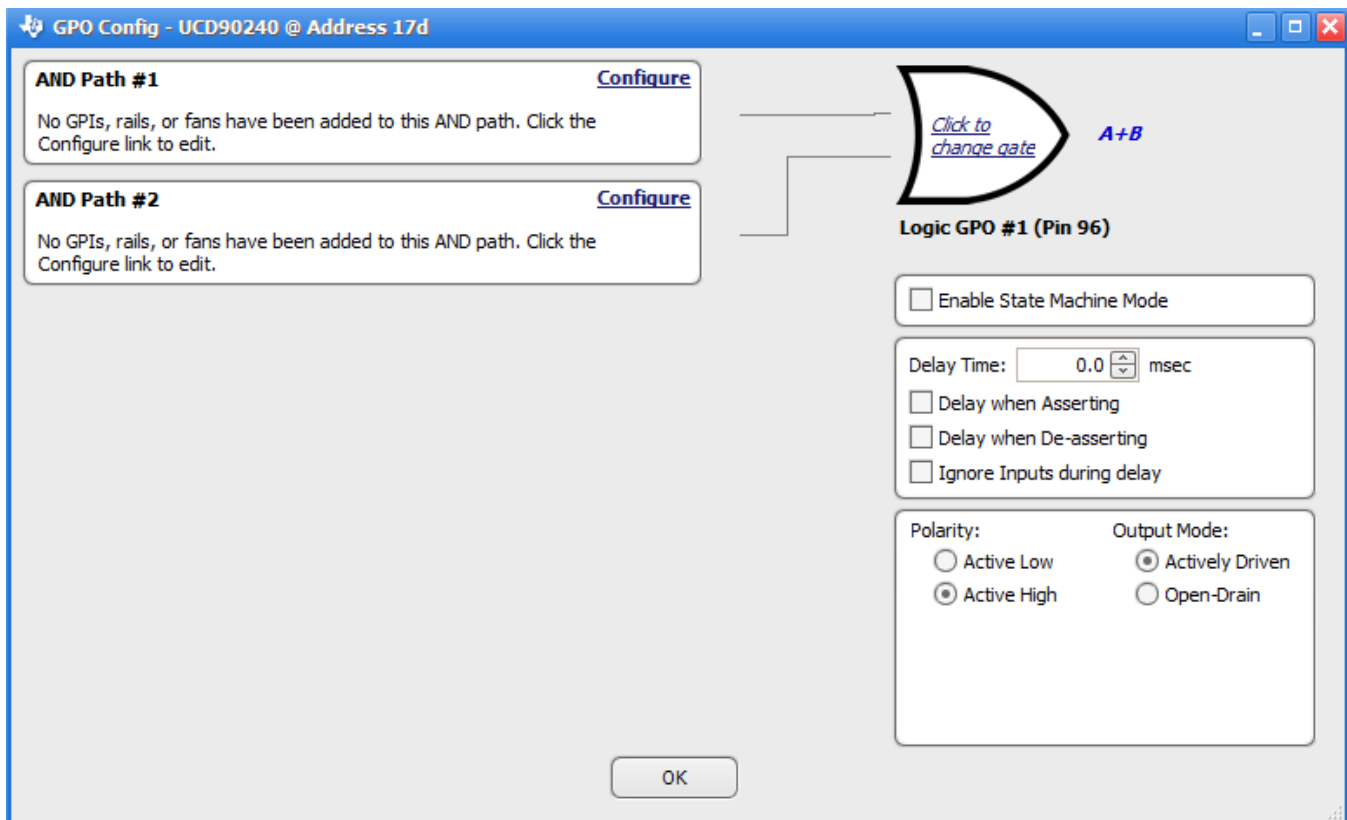

Figure 14. Boolean Logic Builder Interface.

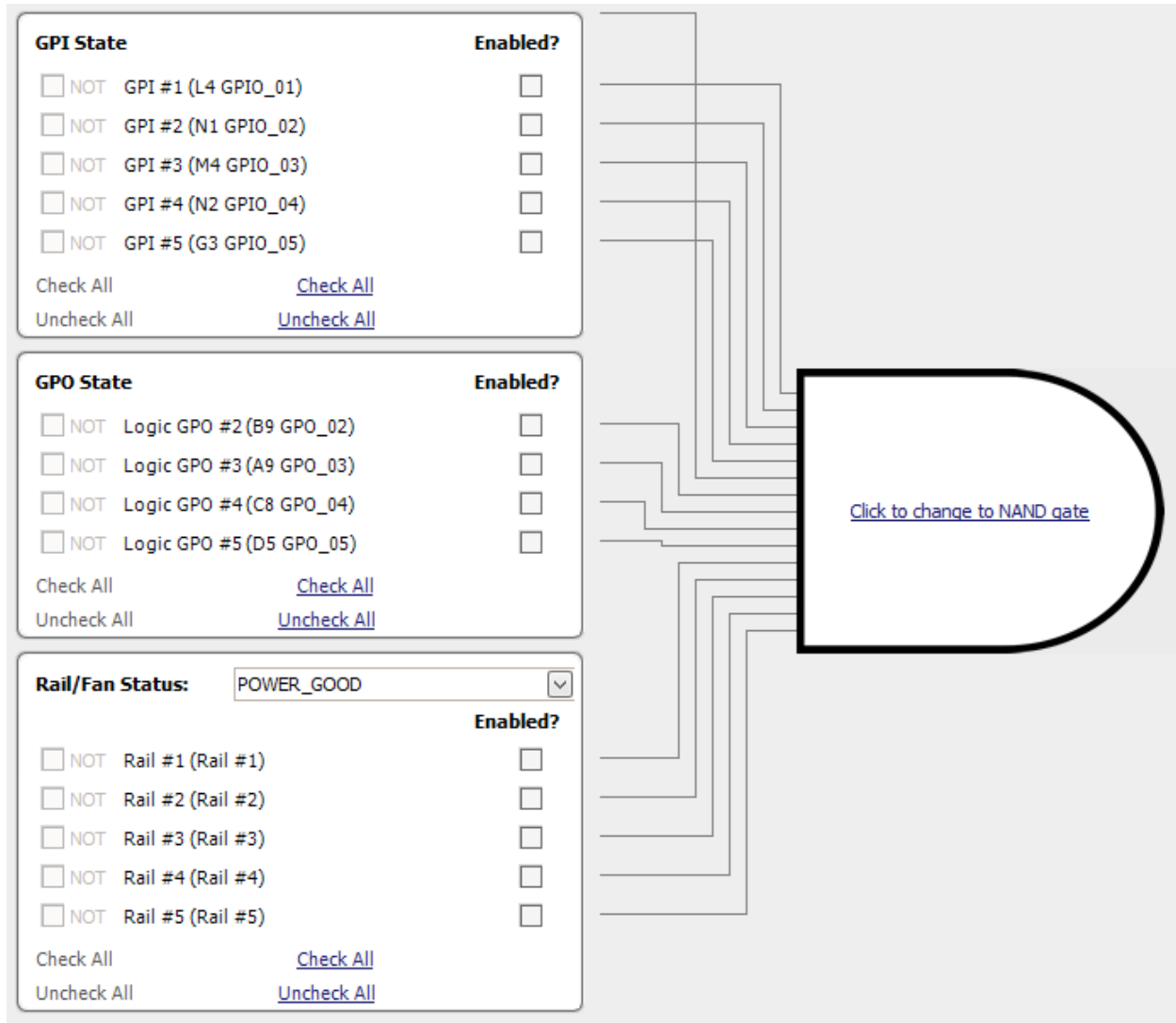

Figure 15. AND Path Configuration.

Table 2. Selectable Rail Statuses in Boolean Logic Builder

RAIL-STATUS TYPES		
POWER_GOOD	IOUT_OC_FAULT	TON_MAX_FAULT
MARGIN_EN	IOUT_OC_WARN	TOFF_MAX_WARN
MRG_LOW_nHIGH	IOUT_UC_FAULT	TON_MAX_FAULT_LATCH
VOUT_OV_FAULT	IOUT_OC_FAULT_LATCH	TOFF_MAX_WARN_LATCH
VOUT_OV_WARN	IOUT_OC_WARN_LATCH	SEQ_ON_TIMEOUT
VOUT_UV_WARN	IOUT_UC_FAULT_LATCH	SEQ_OFF_TIMEOUT
VOUT_UV_FAULT	TEMP_OT_FAULT	SEQ_ON_TIMEOUT_LATCH
VOUT_OV_FAULT_LATCH	TEMP_OT_WARN	SEQ_OFF_TIMEOUT_LATCH
VOUT_OV_WARN_LATCH	TEMP_OT_FAULT_LATCH	SYSTEM_WATCHDOG_TIMEOUT
VOUT_UV_WARN_LATCH	TEMP_OT_WARN_LATCH	SYSTEM_WATCHDOG_TIMEOUT_LATCH
VOUT_UV_FAULT_LATCH		

Each LGPO can be also configured as a simple state machine. The configuration checkbox is in shown in [Figure 14](#). In state machine mode, the top-level logic gate is omitted; only one of the two AND paths will be evaluated; the output of the state machine is the result of the active AND Path. The evaluation initially starts with AND Path #1. If the evaluation result is TRUE, AND Path #1 will stay active until its evaluation result becomes FALSE. When AND Path#1's output becomes FALSE, AND Path #2 will be become active in the next evaluation cycle. AND Path #2 will stay active until its evaluation result becomes TRUE, then AND Path #1 will become active in the next evaluation cycle. An evaluation cycle is triggered when any input signal to the state machine changes state.

GPO1 to GPO8 outputs are internally synchronized to the same clock edge to change states together. GPO9 to GPO12 outputs are internally synchronized and change states together. GPO 1-8 and GPO 9-12 outputs status are updated within a 1~3 μ s window.

7.3.9 Margining Configuration

UCD90240 can provide accurate closed-loop margining for up to 24 voltage rails. System reliability can be improved through four-corner testing during system verification. During four-corner testing, the system is operated at the minimum and maximum expected ambient temperature and with each power supply set to the minimum and maximum output voltage, commonly referred to as margining. Margining can be controlled over PMBus using the OPERATION command or by configuring two GPI pins as margin-EN and margin-UP/DOWN inputs. The MARGIN_CONFIG command in the *UCD90xxx Sequencer and System Health Controller PMBus Command Reference* describes several margining options, including ignoring faults while margining and using closed-loop margining to trim the rail output voltage.

UCD90240 provides 24 PWM output pins for closed-loop margining. A block diagram of margining circuit is shown in [Figure 16](#). An external RC network converts the PWM pulses into a DC margining voltage. The margining voltage is connected to the power supply's feedback node through a resistor. The feedback node voltage is thus slightly pulled up/down by the margining voltage, causing the rail output voltage to change. The rail output voltage is monitored by UCD90240, and the margining PWM duty cycle is adjusted accordingly such that the rail output voltage is regulated at the margin-high/low voltages defined by the user. Effectively, the DC set point of the margined power supply is overwritten by UCD90240's margin control loop. The margin control loop is extremely slow such that it does not interfere with the power supply's control loop.

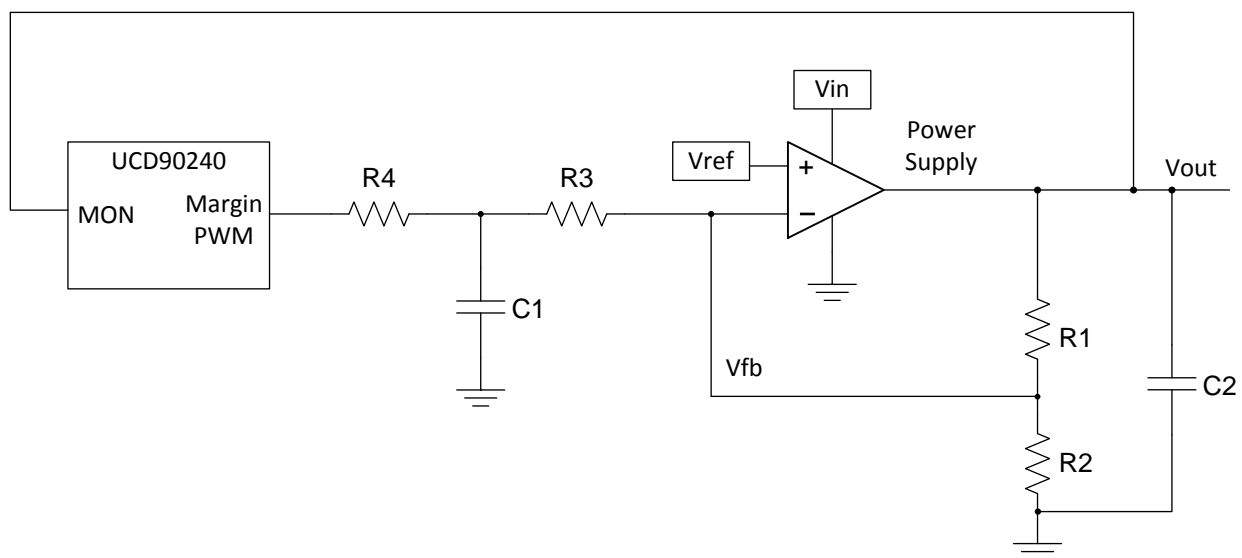

Figure 16. Block Diagram of Margining Circuit

Margining pins can be configured under the Pin Assignment tab, as shown in [Figure 17](#). When not margining, the margin pin can operate in one of three modes: Tri-State, Active Trim, and Active Duty Cycle. Tri-State mode will set the margin pin to high-impedance. Active Trim mode will continuously trim the DC output voltage. Active Duty Cycle mode will provide a user-defined fixed PWM duty cycle as shown in [Figure 17](#).

Rail #1 Trim/Margining

PWM Config:

Duty Cycle: %

Frequency: kHz

Frequency can be 1 kHz to 1 MHz

Margin Mode:

Tri-State
When not margining, the PWM pin is tri-stated.

Active Trim
When not margining, the PWM duty-cycle is continuously adjusted to keep the voltage at VOUT_COMMAND.

Active Duty Cycle
When not margining, the PWM duty-cycle is set to a fixed duty-cycle.

Ignore faults
When margining is enabled with a pin, this determines if faults (over-voltage and under-voltage) are ignored or not.

Increase Duty Cycle increases Voltage
When margining, this determines if increasing duty cycle will increase or decrease voltage

Figure 17. Margining Configuration Dropdown Window (Configure ► Pin Assignment tab)

7.3.10 Pin Selected Rail States Configuration

UCD90240 allows users to use up to three GPI pins to control up to eight rail states. Each rail state enables and disables certain rails. This feature is useful to implement system low-power modes, such as those compliant with the Advanced Configuration and Power Interface (ACPI) specification. The Pin Selected States function can be configured under the Pin Selected States tab, as shown in [Figure 18](#).

If a new state is presented on the GPI pins, and a rail is commanded to turn on, it will do so according to its sequence-on dependencies and delays. If a rail is commanded to turn off by a new state, it can be configured to immediately turn off (Immediate Off), or to turn off with its sequence-off dependencies and delays (Soft Off). If a rail is commanded to remain in the same on/off state, no action will take place.

The Pin Selected Rail States function is implemented by modifying OPERATION command. Therefore, in order to use this function to control rail states, the related rails must be configured to use OPERATION command in *On/Off Config* (shown in [Figure 3](#)).

The Pin Selected States feature always uses the first three configured GPI pins to select system states. When selecting a new system state, state changes on GPI pins must be completed within 1 μ s, otherwise an unintended system state may be selected. See the *UCD90xxx Sequencer and System Health Controller PMBus Command Reference* for complete configuration settings of Pin Selected States.

Pin Selected Rail States Config											
GPI 2 GPIO_03 GPI #3	GPI 1 GPIO_02 GPI #2	GPI 0 GPIO_01 GPI #1	State	Enabled	Turn Off Mode	Rail #1	Rail #2	Rail #3	Rail #4	Rail #5	
De-Asserted	De-Asserted	De-Asserted	0	<input checked="" type="checkbox"/>	Immediate Off	Off	Off	Off	Off	Off	All On All Off
De-Asserted	De-Asserted	Asserted	1	<input checked="" type="checkbox"/>	Soft Off	On	On	On	On	On	All On All Off
De-Asserted	Asserted	De-Asserted	2	<input type="checkbox"/>	Immediate Off	Off	Off	Off	Off	Off	All On All Off
De-Asserted	Asserted	Asserted	3	<input type="checkbox"/>	Immediate Off	On	On	On	On	On	All On All Off
Asserted	De-Asserted	De-Asserted	4	<input type="checkbox"/>	Immediate Off	Off	Off	Off	Off	Off	All On All Off
Asserted	De-Asserted	Asserted	5	<input type="checkbox"/>	Immediate Off	On	On	On	On	On	All On All Off
Asserted	Asserted	De-Asserted	6	<input type="checkbox"/>	Immediate Off	Off	Off	Off	Off	Off	All On All Off
Asserted	Asserted	Asserted	7	<input type="checkbox"/>	Immediate Off	On	On	On	On	On	All On All Off

Figure 18. Pin Selected States Configuration Window (Configure ► Pin Assignment tab)

7.3.11 Watchdog Timer

UCD90240 provides a watchdog timer (WDT). The WDT can be reset by toggling a watchdog input (WDI) pin. If WDI is not toggled within a programmed period, the WDT will time out. As a result, a watchdog output (WDO) pin will be asserted (or generate a pulse) in order to provide a system-reset signal.

The WDI and WDO pins are GPIO pins and are only optional. The WDI can be replaced by SYSTEM_WATCHDOG_RESET command sent over PMBus. The WDO can be manifested through the Boolean Logic defined GPOs, or its function can be integrated into the System Reset pin configured in the System Reset function (System Reset function will be discussed in the SYSTEM RESET FUNCTION section).

The WDT timer is programmable from 0.001s to 258.048s. See the *UCD90xxx Sequencer and System Health Controller PMBus Command Reference* for details on configuring the watchdog timer.

After a timeout, the WDT can be restarted by toggling the WDI pin or by writing a SYSTEM_WATCHDOG_RESET command over PMBus. A watchdog timing diagram is shown in Figure 19.

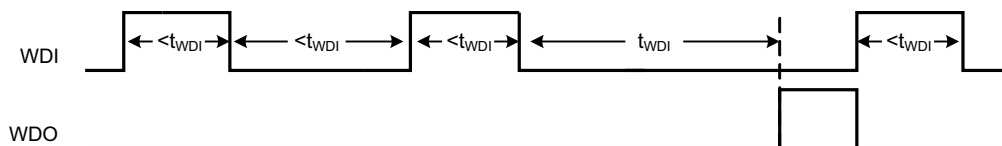

Figure 19. Watchdog Timer Operation Timing Diagram

The WDT can be active immediately at power up or has an initial wait time. Table 3 lists the programmable wait times before the WDT operation begins.

Table 3. WDT Initial Wait Time

0 ms
100 ms
200 ms
400 ms
800 ms
1.6 s
3.2 s

Table 3. WDT Initial Wait Time (continued)

6.4 s
12.8 s
25.6 s
51.2 s
102.4 s
204.8 s
409.6 s
819.2 s
1638.4 s

7.3.12 System Reset Function

System Reset function can generate a programmable *System Reset* signal through a GPIO pin. The *System Reset* signal is deasserted when the selected rail voltages reach their respective Power Good On thresholds and the selected GPIs are asserted, plus a programmable delay time. Available options for the system-reset delay time are summarized in [Table 4](#).

The System Reset signal can be asserted immediately when any of the selected rail voltage falls below Power Good Off threshold, or any selected GPI is deasserted. Alternatively, the System Reset signal can be configured as a pulse once Power Good On is achieved. An example in [Figure 20](#) illustrates the difference of the two configurations. The pulse width can be configured between 0.001 s to 32.256 s. See the UCD90xxx Sequencer and System Health Controller PMBus Command Reference for pulse width configuration details.

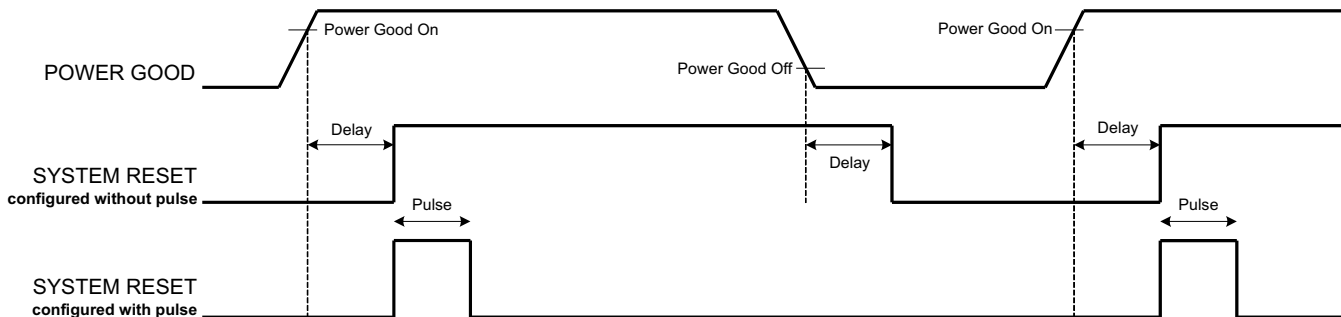

Figure 20. System Reset with and without Pulse Setting (Active Low).

The *System Reset* signal can also integrate watchdog timer. An example is shown in [Figure 21](#). In [Figure 21](#), the first delay on System Reset is for the initial reset release that would enable the CPU once all necessary voltage rails are Power Good. The watchdog is configured with a Start Time and a Reset Time. If these times expire and timeout occurs, it means that the CPU providing the WDI signal is not operating. The *System Reset* signal is then toggled either using a Delay or GPI Tracking Release Delay to see if the CPU recovers.

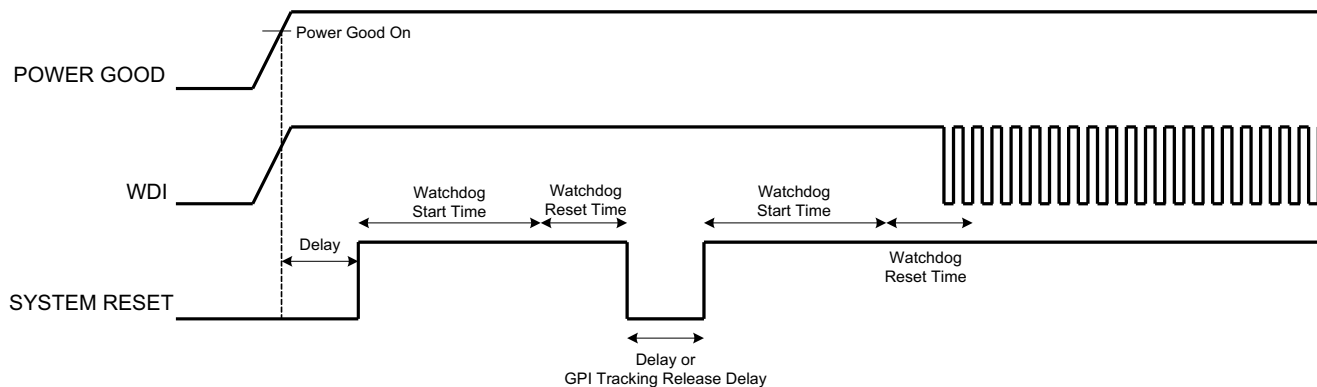

Figure 21. System Reset with Watchdog

Table 4. System Reset Delay

DELAY
0 ms
1 ms
2 ms
4 ms
8 ms
16 ms
32 ms
64 ms
128 ms
256 ms
512 ms
1.02 s
2.05 s
4.10 s
8.19 s
16.38 s
32.8 s

The default state of the System Reset pin is Assert. When the System Reset function is configured in-circuit via PMBus commands during normal operation, the System Reset pin will briefly assert by default, even if conditions for deassert are present. This is because the firmware requires a finite time to examine the deassert conditions.

7.3.13 Cascading Multiple Devices

Multiple UCD90240 devices can work together and coordinate when faults happen

Up to four GPI pins can be configured as *Fault Pins*. Each *Fault Pin* is connected to a *Fault Bus*. Each *Fault Bus* is pulled up to 3.3 V by a 10-kΩ resistor. All the UCD90240 devices on the same *Fault Bus* are informed of the same fault condition. An example of Fault Pin connections is shown in [Figure 22](#).

When there is no fault on a *Fault Bus*, the *Fault Pins* are digital input pins and listen to the *Fault Bus*. When one or multiple UCD90240 devices detect a rail fault, the corresponding *Fault Pin* is turned into active driven low state, pulling down the *Fault Bus* and informing all other UCD90240 devices of the corresponding fault. This way, a coordinated action can be taken across multiple devices. After the fault is cleared, the state of the *Fault Pin* is turned back to an input pin.

Any of the 24 rails can be assigned to one or multiple *Fault Pins*. The configuration window is shown in [Figure 23](#).

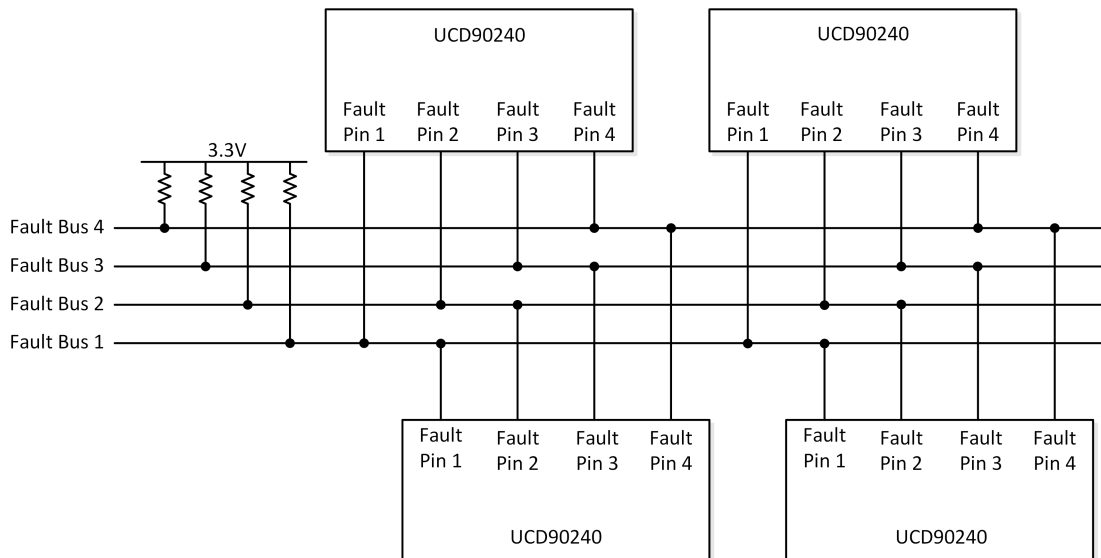

Figure 22. Example of Fault Pin Connections

Fault Pins Config

Pin #	Enable	Pin Selection	Pin Polarity	System Watchdog Timeout	Resequene Error																																																
1	<input checked="" type="checkbox"/>	Pin M11 GPIO_10	Active Low	<input checked="" type="checkbox"/>	<input type="checkbox"/>																																																
	Pages	<table border="1"> <tr> <td>23</td><td>22</td><td>21</td><td>20</td><td>19</td><td>18</td><td>17</td><td>16</td><td>15</td><td>14</td><td>13</td><td>12</td><td>11</td><td>10</td><td>9</td><td>8</td><td>7</td><td>6</td><td>5</td><td>4</td><td>3</td><td>2</td><td>1</td><td>0</td> </tr> <tr> <td>0</td><td>0</td><td>0</td><td>0</td><td>0</td><td>0</td><td>0</td><td>0</td><td>0</td><td>0</td><td>0</td><td>0</td><td>0</td><td>0</td><td>0</td><td>0</td><td>0</td><td>0</td><td>0</td><td>0</td><td>1</td><td>1</td><td>1</td><td>1</td> </tr> </table>				23	22	21	20	19	18	17	16	15	14	13	12	11	10	9	8	7	6	5	4	3	2	1	0	0	0	0	0	0	0	0	0	0	0	0	0	0	0	0	0	0	0	0	0	1	1	1	1
23	22	21	20	19	18	17	16	15	14	13	12	11	10	9	8	7	6	5	4	3	2	1	0																														
0	0	0	0	0	0	0	0	0	0	0	0	0	0	0	0	0	0	0	0	1	1	1	1																														
2	<input checked="" type="checkbox"/>	Pin N12 GPIO_08	Active Low	<input type="checkbox"/>	<input type="checkbox"/>																																																
	Pages	<table border="1"> <tr> <td>23</td><td>22</td><td>21</td><td>20</td><td>19</td><td>18</td><td>17</td><td>16</td><td>15</td><td>14</td><td>13</td><td>12</td><td>11</td><td>10</td><td>9</td><td>8</td><td>7</td><td>6</td><td>5</td><td>4</td><td>3</td><td>2</td><td>1</td><td>0</td> </tr> <tr> <td>0</td><td>0</td><td>0</td><td>0</td><td>0</td><td>0</td><td>0</td><td>0</td><td>0</td><td>0</td><td>0</td><td>0</td><td>0</td><td>0</td><td>0</td><td>0</td><td>1</td><td>1</td><td>1</td><td>1</td><td>0</td><td>0</td><td>0</td><td>0</td> </tr> </table>				23	22	21	20	19	18	17	16	15	14	13	12	11	10	9	8	7	6	5	4	3	2	1	0	0	0	0	0	0	0	0	0	0	0	0	0	0	0	0	0	1	1	1	1	0	0	0	0
23	22	21	20	19	18	17	16	15	14	13	12	11	10	9	8	7	6	5	4	3	2	1	0																														
0	0	0	0	0	0	0	0	0	0	0	0	0	0	0	0	1	1	1	1	0	0	0	0																														
3	<input checked="" type="checkbox"/>	Pin G3 GPIO_05	Active Low	<input type="checkbox"/>	<input checked="" type="checkbox"/>																																																
	Pages	<table border="1"> <tr> <td>23</td><td>22</td><td>21</td><td>20</td><td>19</td><td>18</td><td>17</td><td>16</td><td>15</td><td>14</td><td>13</td><td>12</td><td>11</td><td>10</td><td>9</td><td>8</td><td>7</td><td>6</td><td>5</td><td>4</td><td>3</td><td>2</td><td>1</td><td>0</td> </tr> <tr> <td>0</td><td>0</td><td>0</td><td>0</td><td>0</td><td>0</td><td>0</td><td>0</td><td>0</td><td>0</td><td>0</td><td>0</td><td>0</td><td>0</td><td>0</td><td>0</td><td>0</td><td>0</td><td>0</td><td>0</td><td>0</td><td>0</td><td>0</td><td>0</td> </tr> </table>				23	22	21	20	19	18	17	16	15	14	13	12	11	10	9	8	7	6	5	4	3	2	1	0	0	0	0	0	0	0	0	0	0	0	0	0	0	0	0	0	0	0	0	0	0	0	0	0
23	22	21	20	19	18	17	16	15	14	13	12	11	10	9	8	7	6	5	4	3	2	1	0																														
0	0	0	0	0	0	0	0	0	0	0	0	0	0	0	0	0	0	0	0	0	0	0	0																														
4	<input checked="" type="checkbox"/>	Pin D10 GPIO_06	Active Low	<input type="checkbox"/>	<input type="checkbox"/>																																																
	Pages	<table border="1"> <tr> <td>23</td><td>22</td><td>21</td><td>20</td><td>19</td><td>18</td><td>17</td><td>16</td><td>15</td><td>14</td><td>13</td><td>12</td><td>11</td><td>10</td><td>9</td><td>8</td><td>7</td><td>6</td><td>5</td><td>4</td><td>3</td><td>2</td><td>1</td><td>0</td> </tr> <tr> <td>1</td><td>0</td><td>0</td><td>0</td><td>0</td><td>0</td><td>0</td><td>1</td><td>0</td><td>0</td><td>0</td><td>0</td><td>0</td><td>1</td><td>0</td><td>0</td><td>0</td><td>0</td><td>0</td><td>0</td><td>0</td><td>0</td><td>0</td><td>0</td> </tr> </table>				23	22	21	20	19	18	17	16	15	14	13	12	11	10	9	8	7	6	5	4	3	2	1	0	1	0	0	0	0	0	0	1	0	0	0	0	0	1	0	0	0	0	0	0	0	0	0	0
23	22	21	20	19	18	17	16	15	14	13	12	11	10	9	8	7	6	5	4	3	2	1	0																														
1	0	0	0	0	0	0	1	0	0	0	0	0	1	0	0	0	0	0	0	0	0	0	0																														

This Read/Write block command configures the function of a given fault pin. This command allows pins to be configured as fault-influenced outputs. The state of the output pin is determined by a selection of GPIs and any faults of a selection of rails. The same fault pin could also be configured as GPI pin. In this way, when there is no fault, the pin behaves as a GPI and once there is fault inside the system, this pin is changed to a fault pin and output a signal based on the configuration

Figure 23. Example Fault Pins Configuration Window (Configure ► Fault Pins tab)

A SYNC_CLK pin is used as a single-wire time synchronization method. A Master chip constantly drives a 5kHz clocks to the Slave devices. This offers a precise time base for multiple UCD90240 devices to respond to the same fault event at the same time. The configuration window is shown in Figure 24. If the system only consists of a single UCD90240, it is recommended to configure this pin as master clock output. The SYNC_CLK output can be used as a time base for other purposes if needed.

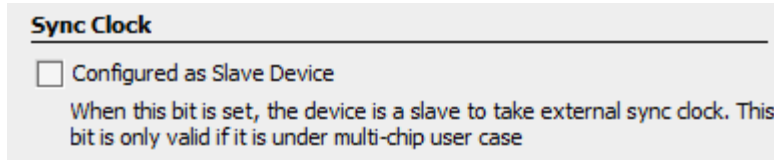

Figure 24. Sync Clock Configuration (Configure ► Other Config tab)

7.3.14 Voltage Monitoring

UCD90240 monitors up to 24 analog inputs including voltages, current, and temperature. FUSION GUI or a PMBus host can poll data from UCD90240. FUSION GUI displays monitored rail voltage, current, and temperature information on its Monitor page. This is especially useful for debugging system-level issues. The Monitor page interface is shown in Figure 25.

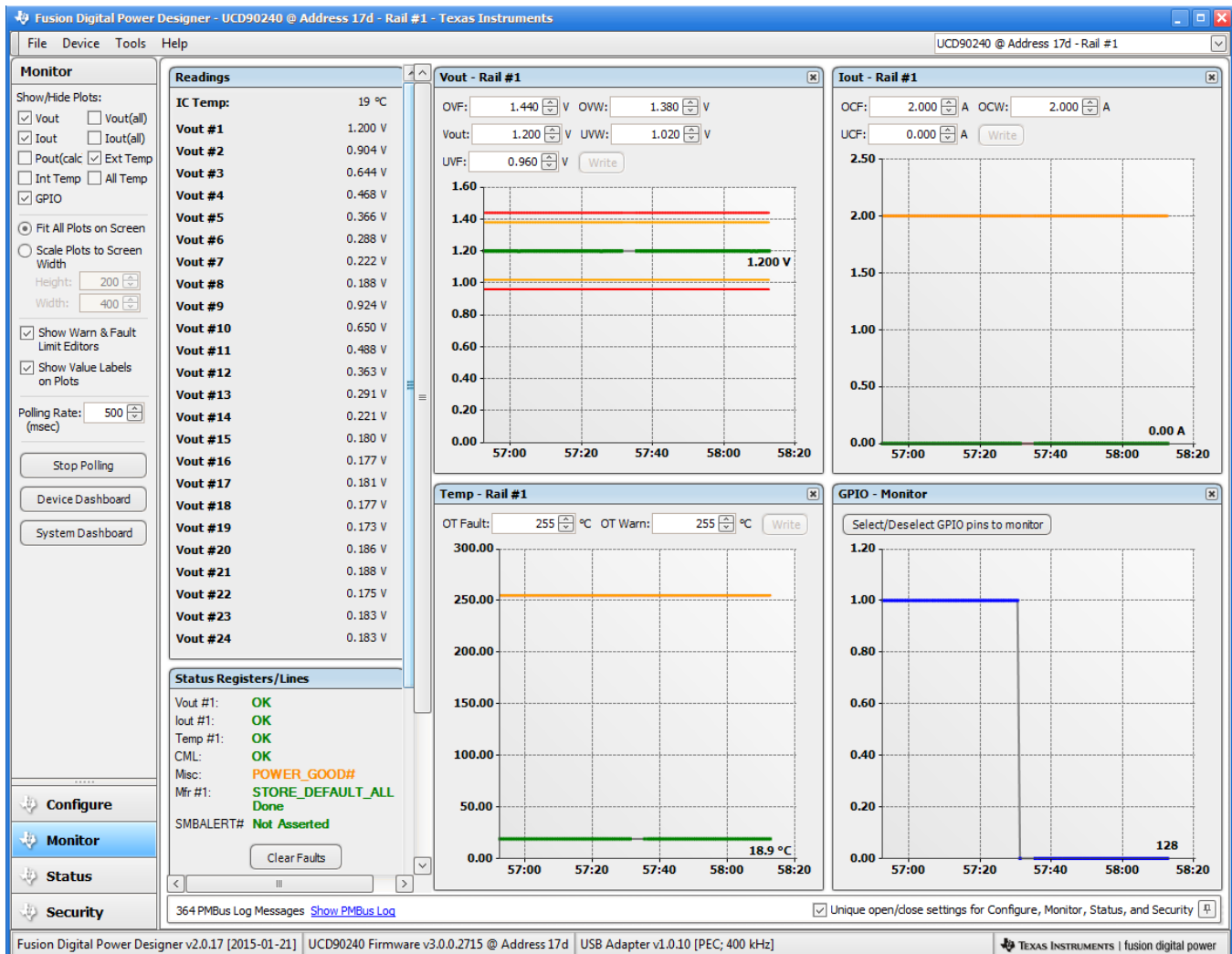

Figure 25. Fusion GUI Monitor Page

7.3.15 Status Monitoring

The UCD90240 has status registers for each rail. Faults and warnings are logged into EEPROM memory to assist system troubleshooting. The status registers (Figure 26) and the fault log (Figure 27) can be accessed from Fusion GUI as well as PMBus. See the *UCD90xxx Sequencer and System Health Controller PMBus Command Reference (SLVU352)* and the PMBus Specification for detailed descriptions of each status register and supported PMBus commands.

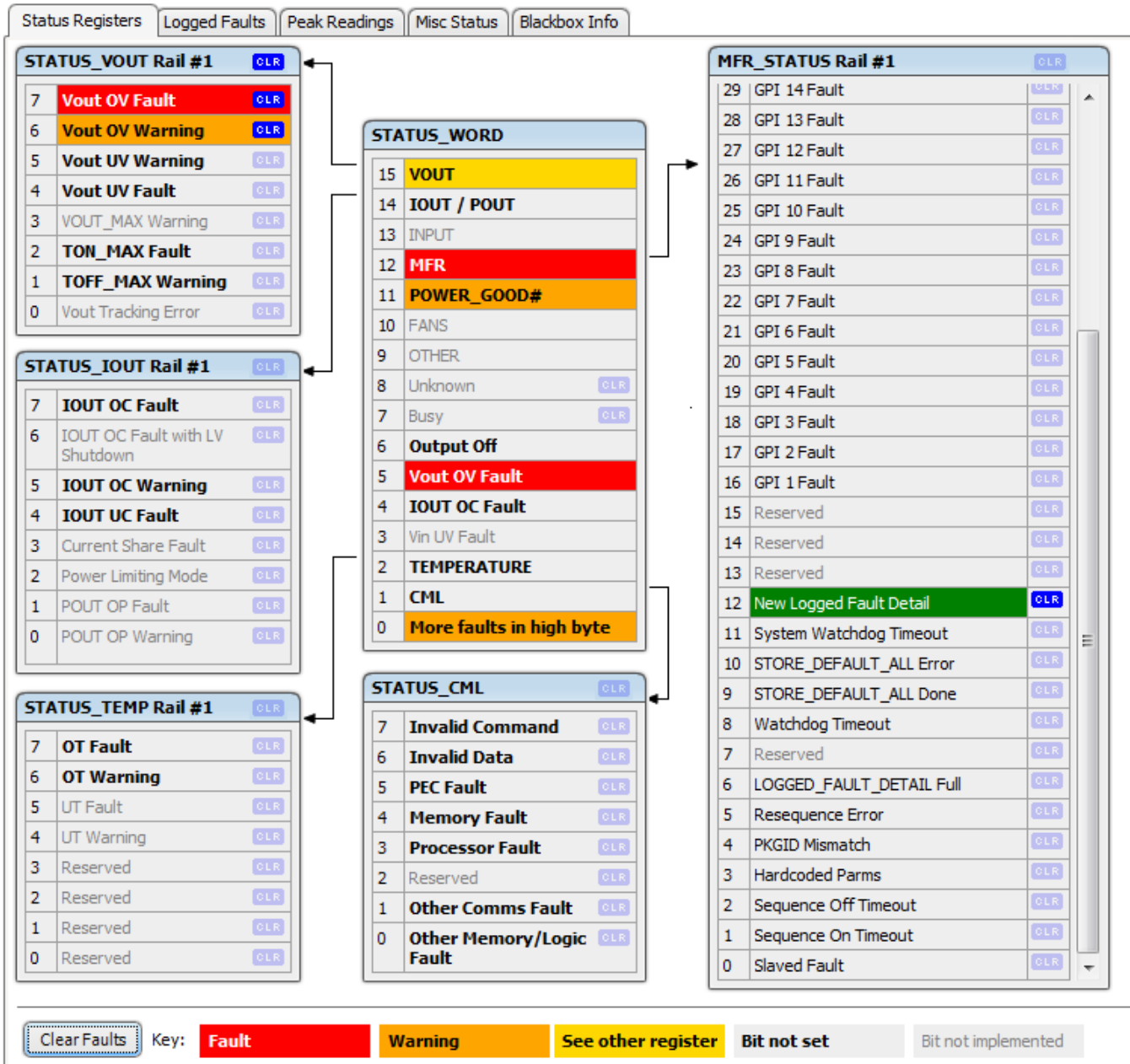

Figure 26. Fusion GUI Rail Status Registers (Status ► Status Registers tab)

Status Registers	Logged Faults	Peak Readings	Misc Status	Blackbox Info																																																																																										
<table border="1"> <thead> <tr> <th colspan="2">Common</th> <th colspan="6">GPIs</th> <th colspan="2">Rail #1 Faults</th> </tr> </thead> <tbody> <tr> <td>7</td><td>Reserved</td> <td>23</td><td>GPI 24 Fault</td> <td>15</td><td>GPI 16 Fault</td> <td>7</td><td>GPI 8 Fault</td> <td>7</td><td>SEQ_OFF_TIMEOUT</td> </tr> <tr> <td>6</td><td>Reserved</td> <td>22</td><td>GPI 23 Fault</td> <td>14</td><td>GPI 15 Fault</td> <td>6</td><td>GPI 7 Fault</td> <td>6</td><td>SEQ_ON_TIMEOUT</td> </tr> <tr> <td>5</td><td>Reserved</td> <td>21</td><td>GPI 22 Fault</td> <td>13</td><td>GPI 14 Fault</td> <td>5</td><td>GPI 6 Fault</td> <td>5</td><td>OT Fault</td> </tr> <tr> <td>4</td><td>Reserved</td> <td>20</td><td>GPI 21 Fault</td> <td>12</td><td>GPI 13 Fault</td> <td>4</td><td>GPI 5 Fault</td> <td>4</td><td>IOUT UC Fault</td> </tr> <tr> <td>3</td><td>Watchdog Timeout</td> <td>19</td><td>GPI 20 Fault</td> <td>11</td><td>GPI 12 Fault</td> <td>3</td><td>GPI 4 Fault</td> <td>3</td><td>IOUT OC Fault</td> </tr> <tr> <td>2</td><td>Re-Sequence Error</td> <td>18</td><td>GPI 19 Fault</td> <td>10</td><td>GPI 11 Fault</td> <td>2</td><td>GPI 3 Fault</td> <td>2</td><td>TON_MAX Fault</td> </tr> <tr> <td>1</td><td>System Watchdog Timeout</td> <td>17</td><td>GPI 18 Fault</td> <td>9</td><td>GPI 10 Fault</td> <td>1</td><td>GPI 2 Fault</td> <td>1</td><td>Vout UV Fault</td> </tr> <tr> <td>0</td><td>Log Not Empty</td> <td>16</td><td>GPI 17 Fault</td> <td>8</td><td>GPI 9 Fault</td> <td>0</td><td>GPI 1 Fault</td> <td>0</td><td>Vout OV Fault</td> </tr> </tbody> </table>					Common		GPIs						Rail #1 Faults		7	Reserved	23	GPI 24 Fault	15	GPI 16 Fault	7	GPI 8 Fault	7	SEQ_OFF_TIMEOUT	6	Reserved	22	GPI 23 Fault	14	GPI 15 Fault	6	GPI 7 Fault	6	SEQ_ON_TIMEOUT	5	Reserved	21	GPI 22 Fault	13	GPI 14 Fault	5	GPI 6 Fault	5	OT Fault	4	Reserved	20	GPI 21 Fault	12	GPI 13 Fault	4	GPI 5 Fault	4	IOUT UC Fault	3	Watchdog Timeout	19	GPI 20 Fault	11	GPI 12 Fault	3	GPI 4 Fault	3	IOUT OC Fault	2	Re-Sequence Error	18	GPI 19 Fault	10	GPI 11 Fault	2	GPI 3 Fault	2	TON_MAX Fault	1	System Watchdog Timeout	17	GPI 18 Fault	9	GPI 10 Fault	1	GPI 2 Fault	1	Vout UV Fault	0	Log Not Empty	16	GPI 17 Fault	8	GPI 9 Fault	0	GPI 1 Fault	0	Vout OV Fault
Common		GPIs						Rail #1 Faults																																																																																						
7	Reserved	23	GPI 24 Fault	15	GPI 16 Fault	7	GPI 8 Fault	7	SEQ_OFF_TIMEOUT																																																																																					
6	Reserved	22	GPI 23 Fault	14	GPI 15 Fault	6	GPI 7 Fault	6	SEQ_ON_TIMEOUT																																																																																					
5	Reserved	21	GPI 22 Fault	13	GPI 14 Fault	5	GPI 6 Fault	5	OT Fault																																																																																					
4	Reserved	20	GPI 21 Fault	12	GPI 13 Fault	4	GPI 5 Fault	4	IOUT UC Fault																																																																																					
3	Watchdog Timeout	19	GPI 20 Fault	11	GPI 12 Fault	3	GPI 4 Fault	3	IOUT OC Fault																																																																																					
2	Re-Sequence Error	18	GPI 19 Fault	10	GPI 11 Fault	2	GPI 3 Fault	2	TON_MAX Fault																																																																																					
1	System Watchdog Timeout	17	GPI 18 Fault	9	GPI 10 Fault	1	GPI 2 Fault	1	Vout UV Fault																																																																																					
0	Log Not Empty	16	GPI 17 Fault	8	GPI 9 Fault	0	GPI 1 Fault	0	Vout OV Fault																																																																																					
<table border="1"> <thead> <tr> <th colspan="2">Rail #2 Faults</th> <th colspan="2">Rail #3 Faults</th> <th colspan="2">Rail #4 Faults</th> <th colspan="2">Rail #5 Faults</th> </tr> </thead> <tbody> <tr> <td>7</td><td>SEQ_OFF_TIMEOUT</td> <td>7</td><td>SEQ_OFF_TIMEOUT</td> <td>7</td><td>SEQ_OFF_TIMEOUT</td> <td>7</td><td>SEQ_OFF_TIMEOUT</td> </tr> <tr> <td>6</td><td>SEQ_ON_TIMEOUT</td> <td>6</td><td>SEQ_ON_TIMEOUT</td> <td>6</td><td>SEQ_ON_TIMEOUT</td> <td>6</td><td>SEQ_ON_TIMEOUT</td> </tr> <tr> <td>5</td><td>OT Fault</td> <td>5</td><td>OT Fault</td> <td>5</td><td>OT Fault</td> <td>5</td><td>OT Fault</td> </tr> <tr> <td>4</td><td>IOUT UC Fault</td> <td>4</td><td>IOUT UC Fault</td> <td>4</td><td>IOUT UC Fault</td> <td>4</td><td>IOUT UC Fault</td> </tr> <tr> <td>3</td><td>IOUT OC Fault</td> <td>3</td><td>IOUT OC Fault</td> <td>3</td><td>IOUT OC Fault</td> <td>3</td><td>IOUT OC Fault</td> </tr> <tr> <td>2</td><td>TON_MAX Fault</td> <td>2</td><td>TON_MAX Fault</td> <td>2</td><td>TON_MAX Fault</td> <td>2</td><td>TON_MAX Fault</td> </tr> <tr> <td>1</td><td>Vout UV Fault</td> <td>1</td><td>Vout UV Fault</td> <td>1</td><td>Vout UV Fault</td> <td>1</td><td>Vout UV Fault</td> </tr> <tr> <td>0</td><td>Vout OV Fault</td> <td>0</td><td>Vout OV Fault</td> <td>0</td><td>Vout OV Fault</td> <td>0</td><td>Vout OV Fault</td> </tr> </tbody> </table>					Rail #2 Faults		Rail #3 Faults		Rail #4 Faults		Rail #5 Faults		7	SEQ_OFF_TIMEOUT	7	SEQ_OFF_TIMEOUT	7	SEQ_OFF_TIMEOUT	7	SEQ_OFF_TIMEOUT	6	SEQ_ON_TIMEOUT	6	SEQ_ON_TIMEOUT	6	SEQ_ON_TIMEOUT	6	SEQ_ON_TIMEOUT	5	OT Fault	5	OT Fault	5	OT Fault	5	OT Fault	4	IOUT UC Fault	4	IOUT UC Fault	4	IOUT UC Fault	4	IOUT UC Fault	3	IOUT OC Fault	3	IOUT OC Fault	3	IOUT OC Fault	3	IOUT OC Fault	2	TON_MAX Fault	2	TON_MAX Fault	2	TON_MAX Fault	2	TON_MAX Fault	1	Vout UV Fault	1	Vout UV Fault	1	Vout UV Fault	1	Vout UV Fault	0	Vout OV Fault	0	Vout OV Fault	0	Vout OV Fault	0	Vout OV Fault																		
Rail #2 Faults		Rail #3 Faults		Rail #4 Faults		Rail #5 Faults																																																																																								
7	SEQ_OFF_TIMEOUT	7	SEQ_OFF_TIMEOUT	7	SEQ_OFF_TIMEOUT	7	SEQ_OFF_TIMEOUT																																																																																							
6	SEQ_ON_TIMEOUT	6	SEQ_ON_TIMEOUT	6	SEQ_ON_TIMEOUT	6	SEQ_ON_TIMEOUT																																																																																							
5	OT Fault	5	OT Fault	5	OT Fault	5	OT Fault																																																																																							
4	IOUT UC Fault	4	IOUT UC Fault	4	IOUT UC Fault	4	IOUT UC Fault																																																																																							
3	IOUT OC Fault	3	IOUT OC Fault	3	IOUT OC Fault	3	IOUT OC Fault																																																																																							
2	TON_MAX Fault	2	TON_MAX Fault	2	TON_MAX Fault	2	TON_MAX Fault																																																																																							
1	Vout UV Fault	1	Vout UV Fault	1	Vout UV Fault	1	Vout UV Fault																																																																																							
0	Vout OV Fault	0	Vout OV Fault	0	Vout OV Fault	0	Vout OV Fault																																																																																							
<table border="1"> <thead> <tr> <th colspan="2">Rail #6 Faults</th> <th colspan="2">Rail #7 Faults</th> <th colspan="2">Rail #8 Faults</th> <th colspan="2">Rail #9 Faults</th> </tr> </thead> <tbody> <tr> <td>7</td><td>SEQ_OFF_TIMEOUT</td> <td>7</td><td>SEQ_OFF_TIMEOUT</td> <td>7</td><td>SEQ_OFF_TIMEOUT</td> <td>7</td><td>SEQ_OFF_TIMEOUT</td> </tr> <tr> <td>6</td><td>SEQ_ON_TIMEOUT</td> <td>6</td><td>SEQ_ON_TIMEOUT</td> <td>6</td><td>SEQ_ON_TIMEOUT</td> <td>6</td><td>SEQ_ON_TIMEOUT</td> </tr> <tr> <td>5</td><td>OT Fault</td> <td>5</td><td>OT Fault</td> <td>5</td><td>OT Fault</td> <td>5</td><td>OT Fault</td> </tr> <tr> <td>4</td><td>IOUT UC Fault</td> <td>4</td><td>IOUT UC Fault</td> <td>4</td><td>IOUT UC Fault</td> <td>4</td><td>IOUT UC Fault</td> </tr> <tr> <td>3</td><td>IOUT OC Fault</td> <td>3</td><td>IOUT OC Fault</td> <td>3</td><td>IOUT OC Fault</td> <td>3</td><td>IOUT OC Fault</td> </tr> <tr> <td>2</td><td>TON_MAX Fault</td> <td>2</td><td>TON_MAX Fault</td> <td>2</td><td>TON_MAX Fault</td> <td>2</td><td>TON_MAX Fault</td> </tr> <tr> <td>1</td><td>Vout UV Fault</td> <td>1</td><td>Vout UV Fault</td> <td>1</td><td>Vout UV Fault</td> <td>1</td><td>Vout UV Fault</td> </tr> <tr> <td>0</td><td>Vout OV Fault</td> <td>0</td><td>Vout OV Fault</td> <td>0</td><td>Vout OV Fault</td> <td>0</td><td>Vout OV Fault</td> </tr> </tbody> </table>					Rail #6 Faults		Rail #7 Faults		Rail #8 Faults		Rail #9 Faults		7	SEQ_OFF_TIMEOUT	7	SEQ_OFF_TIMEOUT	7	SEQ_OFF_TIMEOUT	7	SEQ_OFF_TIMEOUT	6	SEQ_ON_TIMEOUT	6	SEQ_ON_TIMEOUT	6	SEQ_ON_TIMEOUT	6	SEQ_ON_TIMEOUT	5	OT Fault	5	OT Fault	5	OT Fault	5	OT Fault	4	IOUT UC Fault	4	IOUT UC Fault	4	IOUT UC Fault	4	IOUT UC Fault	3	IOUT OC Fault	3	IOUT OC Fault	3	IOUT OC Fault	3	IOUT OC Fault	2	TON_MAX Fault	2	TON_MAX Fault	2	TON_MAX Fault	2	TON_MAX Fault	1	Vout UV Fault	1	Vout UV Fault	1	Vout UV Fault	1	Vout UV Fault	0	Vout OV Fault	0	Vout OV Fault	0	Vout OV Fault	0	Vout OV Fault																		
Rail #6 Faults		Rail #7 Faults		Rail #8 Faults		Rail #9 Faults																																																																																								
7	SEQ_OFF_TIMEOUT	7	SEQ_OFF_TIMEOUT	7	SEQ_OFF_TIMEOUT	7	SEQ_OFF_TIMEOUT																																																																																							
6	SEQ_ON_TIMEOUT	6	SEQ_ON_TIMEOUT	6	SEQ_ON_TIMEOUT	6	SEQ_ON_TIMEOUT																																																																																							
5	OT Fault	5	OT Fault	5	OT Fault	5	OT Fault																																																																																							
4	IOUT UC Fault	4	IOUT UC Fault	4	IOUT UC Fault	4	IOUT UC Fault																																																																																							
3	IOUT OC Fault	3	IOUT OC Fault	3	IOUT OC Fault	3	IOUT OC Fault																																																																																							
2	TON_MAX Fault	2	TON_MAX Fault	2	TON_MAX Fault	2	TON_MAX Fault																																																																																							
1	Vout UV Fault	1	Vout UV Fault	1	Vout UV Fault	1	Vout UV Fault																																																																																							
0	Vout OV Fault	0	Vout OV Fault	0	Vout OV Fault	0	Vout OV Fault																																																																																							

Figure 27. Fusion GUI Logged Faults(Status ► Logged Faults tab)

7.3.16 Data and Error Logging to EEPROM Memory

The UCD90240 provides fault log, device reset counter, and peak readings for each rail. To reduce stress on the EEPROM memory, a 30-second timer is started if a measured value exceeds the previously logged value. Only the highest value from the 30-second interval is written from RAM to EEPROM.

Faults are stored in EEPROM memory and are accessible over PMBus. Each logged fault includes the following information:

- Rail number
- Fault type
- Fault time since previous device reset
- Last measured rail voltage

The total number of device resets is also stored to EEPROM memory. The value can be reset using PMBus.

The runtime clock value is logged into EEPROM when a power down is detected. This allows UCD90240 to preserve the runtime clock value through resets or power cycles.

It is also possible to update and calibrate the UCD90240 internal runtime clock via a PMBus host. For example, a host processor with a real-time clock could periodically update the UCD90240 runtime clock to a value that corresponds to the actual date and time. The host must translate the UCD90240 timer value back into appropriate units, based on the usage scenario chosen. See the REAL_TIME_CLOCK command in the *UCD90xxx Sequencer and System Health Controller PMBus Command Reference* for more details.

7.3.17 Black Box First Fault Logging

The first fault in a system failure event is usually critical to diagnose the root cause. An innovative Black Box Fault Logging feature is introduced in UCD90240 to accelerate the debugging process. When UCD90240 detects the first fault, all rails' and I/O pins' statuses are saved into a special area of EEPROM that is reserved for this function. The subsequent faults and monitoring statuses will not be saved in the Black Box Fault Log, but they will still be logged into the standard fault log. The Black Box Fault Log must be cleared in order to catch the next fault.

The screenshot shows the 'Blackbox Info' tab in the status registers window. It displays the following information:

- Fault Info:**
 - Fault ID: VOUT OV Fault on Rail # 1
 - Fault Value: 1.44140625 V
 - Time Stamp: Tuesday, February 10, 2015 1:34:08 PM
- GPI Statuses:** A row of 24 status indicators (GPI # 1-24). GPI # 1 is green, and all others are grey.
- GPO Statuses:** A row of 12 status indicators (GPO # 1-12). GPO # 1 is green, and all others are grey.
- Rail Status Table:** A table with columns for Rail #, OV WARN, UV WARN, OC WARN, TOFF WARN, OT WARN, Voltage, Current, and Temperature.

Rail #	OV WARN	UV WARN	OC WARN	TOFF WARN	OT WARN	Voltage	Current	Temperature
1	<input checked="" type="checkbox"/>	<input type="checkbox"/>	<input type="checkbox"/>	<input type="checkbox"/>	<input type="checkbox"/>	1.4414 V	N/A	N/A
2	<input type="checkbox"/>	<input checked="" type="checkbox"/>	<input type="checkbox"/>	<input type="checkbox"/>	<input type="checkbox"/>	1.1140 V	N/A	N/A
3	<input type="checkbox"/>	<input type="checkbox"/>	<input type="checkbox"/>	<input type="checkbox"/>	<input type="checkbox"/>	0.7852 V	N/A	N/A
4	<input type="checkbox"/>	<input type="checkbox"/>	<input type="checkbox"/>	<input type="checkbox"/>	<input type="checkbox"/>	0.5618 V	N/A	N/A
5	<input type="checkbox"/>	<input type="checkbox"/>	<input type="checkbox"/>	<input type="checkbox"/>	<input type="checkbox"/>	0.4241 V	N/A	N/A
6	<input type="checkbox"/>	<input type="checkbox"/>	<input type="checkbox"/>	<input type="checkbox"/>	<input type="checkbox"/>	0.3113 V	N/A	N/A
7	<input type="checkbox"/>	<input type="checkbox"/>	<input type="checkbox"/>	<input type="checkbox"/>	<input type="checkbox"/>	0.2424 V	N/A	N/A
8	<input type="checkbox"/>	<input type="checkbox"/>	<input type="checkbox"/>	<input type="checkbox"/>	<input type="checkbox"/>	0.1934 V	N/A	N/A
9	<input checked="" type="checkbox"/>	<input checked="" type="checkbox"/>	<input type="checkbox"/>	<input type="checkbox"/>	<input type="checkbox"/>	1.1660 V	N/A	N/A
10	<input type="checkbox"/>	<input checked="" type="checkbox"/>	<input type="checkbox"/>	<input type="checkbox"/>	<input type="checkbox"/>	0.8364 V	N/A	N/A

Figure 28. Black Box Fault Logging Window (Status ► Blackbox Info tab)

7.3.18 PMBUS Address Selection

Three digital input pins are allocated to decode the PMBus address. At power up, UCD90240 detects the logic inputs of the three address pins to determine the configured PMBus address.

Table 5. PMBus Address Configuration

PMBUS_ADDR2	PMBUS_ADDR1	PMBUS_ADDR0	PMBus ADDRESS SELECTED	
L	L	L	17d	00010001b
L	L	H	19d	00010011b
L	H	L	23d	00010111b
L	H	H	49d	00110001b
H	L	L	51d	00110011b
H	L	H	113d	01110001b
H	H	L	115d	01110011b
H	H	H	119d	01110111b

UCD90240 is a PMBus slave but it does not support slave arbitration. Multiple PMBus devices including UCD90240 can work on the same PMBus if all the PMBus addresses meet the following requirement: when perform binary AND operation to any two of the addresses on the bus, the result must always be the lowest address. See UCD90240 application notes for details.

7.3.19 ADC Reference

UCD90240 uses V33A as ADC reference voltage by default. This provides a cost-effective solution. However, internal voltage reference has higher Total Unadjusted Error. Also, voltage variations on V33A will affect ADC readings, such as when the device is powered down. In order to achieve better ADC accuracy, an external voltage reference can be connected to the VREFA+ and VREFA– pins. The external reference voltage should stay in regulation whenever V33D is above V_{BOR} threshold. This allows accurate ADC readings in full V33D operating range.

The external reference voltage level must be configured into the Fusion GUI to give correct ADC readings.

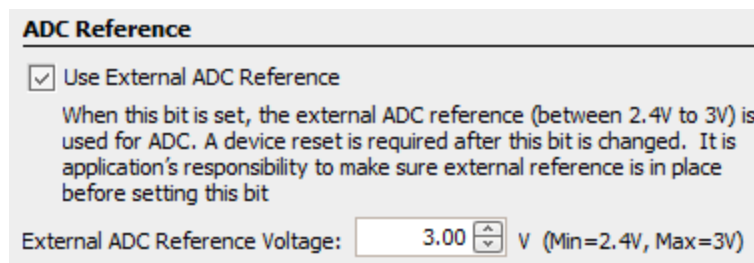

Figure 29. ADC Reference Configuration Window (Configure ► Other Config tab)

7.3.20 Device Reset

The UCD90240 has an integrated power-on reset (POR) circuit which monitors the supply voltage. At power up, the POR detects the V33D rise. When V33D is greater than V_{RESET} , the device comes out of reset.

The device can be forced into the reset state by an external circuit connected to the \overline{RESET} pin. A logic-low voltage on this pin for longer than t_{RESET} sets the device into reset state. The device comes out of reset within t_{IRT} after \overline{RESET} is released to logic-high level.

Any time the device comes out of reset, it begins an initialization routine that lasts typically 27.5 ms. A data flash checksum verification is performed at power up. If the checksum does not match, the device configuration will be wiped out, the PMBALERT# pin will be asserted, and a flag will be set in the status register. A fault-log checksum verification in EEPROM is also performed at power up. Each log entry has a checksum. Only the corrupted log entry will be discarded. During the initialization routine, all I/O pins are held at high impedance state. At the end of initialization, the device begins normal operation as defined by the device configuration.

7.3.21 Brownout

UCD90240 triggers brownout event when V33D drops below V_{BOR} . During brownout, the device continues to write fault logs that happened before the brownout event into the EEPROM. As the supply voltage continues to drop, the device will fully shutdown when V33D is below V_{SHDN} . Any fault event that has not been written into the EEPROM before the device shutdown will be lost.

In the scenario where several faults happen immediately before the brownout event, the device requires 500 μ s to write the first fault event into the EEPROM, and additional 4ms to write the Black Box fault log into the EEPROM. Therefore, in order to preserve at least the first fault log, user must provide enough local capacitance to maintain the V33D rail above V_{SHDN} for 500 μ s (or 4.5ms with the Black Box fault log). Longer holdup time allows more fault events to be written into the EEPROM during brownout. Note that the holdup time is affected by V33D rail capacitance, UCD90240's supply current and external circuits that source current from the rail (for example, LEDs, load current on I/O pins, other devices powered by the same rail, and so forth).

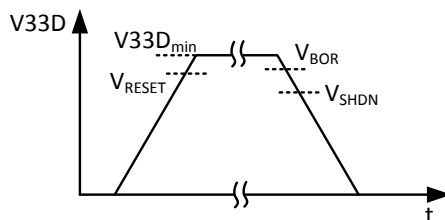

Figure 30. Reset and Brownout Thresholds

7.3.22 Device Configuration and Programming

UCD90240 devices come out of factory with the sequencing and monitoring firmware. They are also configured in such a way that all I/O pins are high-impedance, with no sequencing or fault-response operation. User can use Fusion GUI to configure the device on-line or off-line. Once the configuration is completed, user can generate a configuration file, and import the configuration into other UCD90240 devices

Configuration and programming details are described in Configuration Programming of UCD Devices which is available in Documentation & Help Center under Fusion GUI's Help menu. In general, UCD90240 supports two programming methods:

1. PMBus command over PMBus/I²C.

This method uses a PMBus host to program the device. The PMBus host can be either a host microcontroller or *Fusion GUI* tools. Each PMBus command sends a corresponding parameter(s) into the device. The new parameters are stored in its associated memory (RAM) location. After all the parameters are sent into the device, the PMBus host issues a special command, STORE_DEFAULT_ALL, which writes the RAM data into nonvolatile memory (data flash). *Fusion GUI* normally uses this method to configure a device. Note that, if use *Fusion GUI* tools for on-board programming, the *Fusion GUI* tools must have ownership of the target board's PMBus/I²C bus.

2. Data flash image over PMBus/I²C.

The *Fusion GUI* can export a data flash image in Intel Hex or S-record format. The image file can be directly downloaded into the device's data flash via PMBus/I²C using *Fusion GUI* tools or a dedicated device programmer. The new configuration will take effect after a device reset.

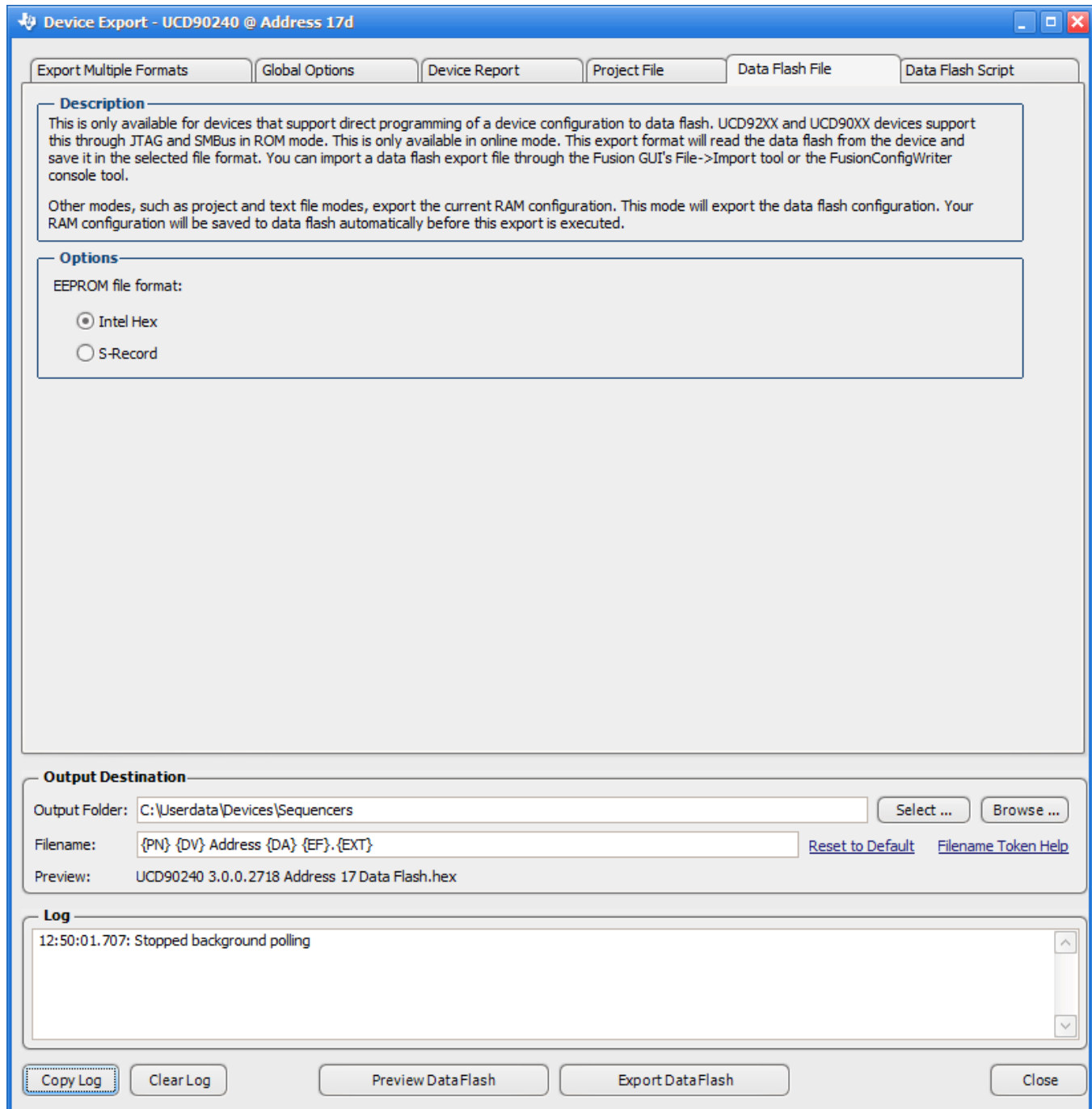

Figure 31. Fusion GUI Configuration Export Tool.

While programming over PMBus /I²C, the UCD90240 must be powered. The PMBus clock and data pins must be accessible and must be pulled high to the same V33D supply that powers the device, with pullup resistors between 1 kΩ and 2 kΩ. Care should be taken to not introduce additional bus capacitance (<100 pF). When using gang programmer to program multiple UCD90240 devices over I²C, programming must be done individually: the clock and data lines must be multiplexed such that only one device is written by the programmer at a time; alternatively, the socket must assign different addresses to each device. For small runs, a socketed board with an I²C header can be used with the standard *Fusion GUI* or manufacturing GUI. Programming also can be done using a single device test fixture.

There may be situations where it is required to update the device configuration in an operating system. The PMBus command method can be used to update thresholds, timeout periods, dependencies, and so forth, while the system is operating. Because the new configuration is written into RAM, it will take effect immediately. However, pin-function-related configurations (for example, change of rails, change of GPI/GPO functions, and so forth) may not work correctly until a device reset. This may be a problem in an operating system. For example, undesired GPI/GPO/System Reset pin states may disable rails that provide power to the UCD90240, and thus terminate the programming process before it is completed. The data flash image method can overcome this problem by directly writing new configuration into the data flash. This allows a full configuration while the system is operating. It is not required to reset the device immediately but the UCD90240 will continue to operate based on previous configuration until a device reset.

The JTAG port is compatible with IEEE Standard 1149.1-1990, Test-Access Port and Boundary Scan Architecture specification. UCD90240 supports boundary scan. Configuration programming via JTAG is not supported on this device.

7.3.23 Internal Fault Management

The UCD90240 verifies the firmware program checksum at each power up. If the checksum does not match, the device will reset. If the device keeps resetting, the SYNC_CLK pin will output repeated pulses with ~250-ms pulse width that can be observed externally.

The configuration data checksum verification is also performed at power up. If the checksum does not match, the device will wipe out all the configuration data. The PMBALERT# pin is asserted and a flag is set in the status register.

A fault-log checksum verification in EEPROM is also performed at power up. Each log entry has a checksum. The corrupted log entry will be discarded.

There is an internal firmware watchdog timer. If it times out, the device resets so that if the firmware program is corrupted, the device goes back to a known state. This is a normal device reset, so all of the I/O pins are held in high-impedance while the device is in reset. Checks are also done on each parameter that is passed, to make sure it falls within the acceptable range.

8 Application and Implementation

NOTE

Information in the following applications sections is not part of the TI component specification, and TI does not warrant its accuracy or completeness. TI's customers are responsible for determining suitability of components for their purposes. Customers should validate and test their design implementation to confirm system functionality.

8.1 Application Information

The UCD90240 can be used to sequence, monitor and margin up to 24 voltage rails. With the cascading feature, up to four UCD90240 devices can manage up to 96 rails and take synchronized fault responses. Typical applications include automatic test equipment, telecommunication and networking equipment, servers and storage systems, and so forth. Device configuration can be performed in Fusion GUI. No coding skill is required.

8.2 Typical Application

[Figure 32](#) shows a simplified system diagram. Only three rails are shown for illustration purpose. Each UCD90240 device can manage up to 24 rails.

Typical Application (continued)

8.2.1 Application Diagram

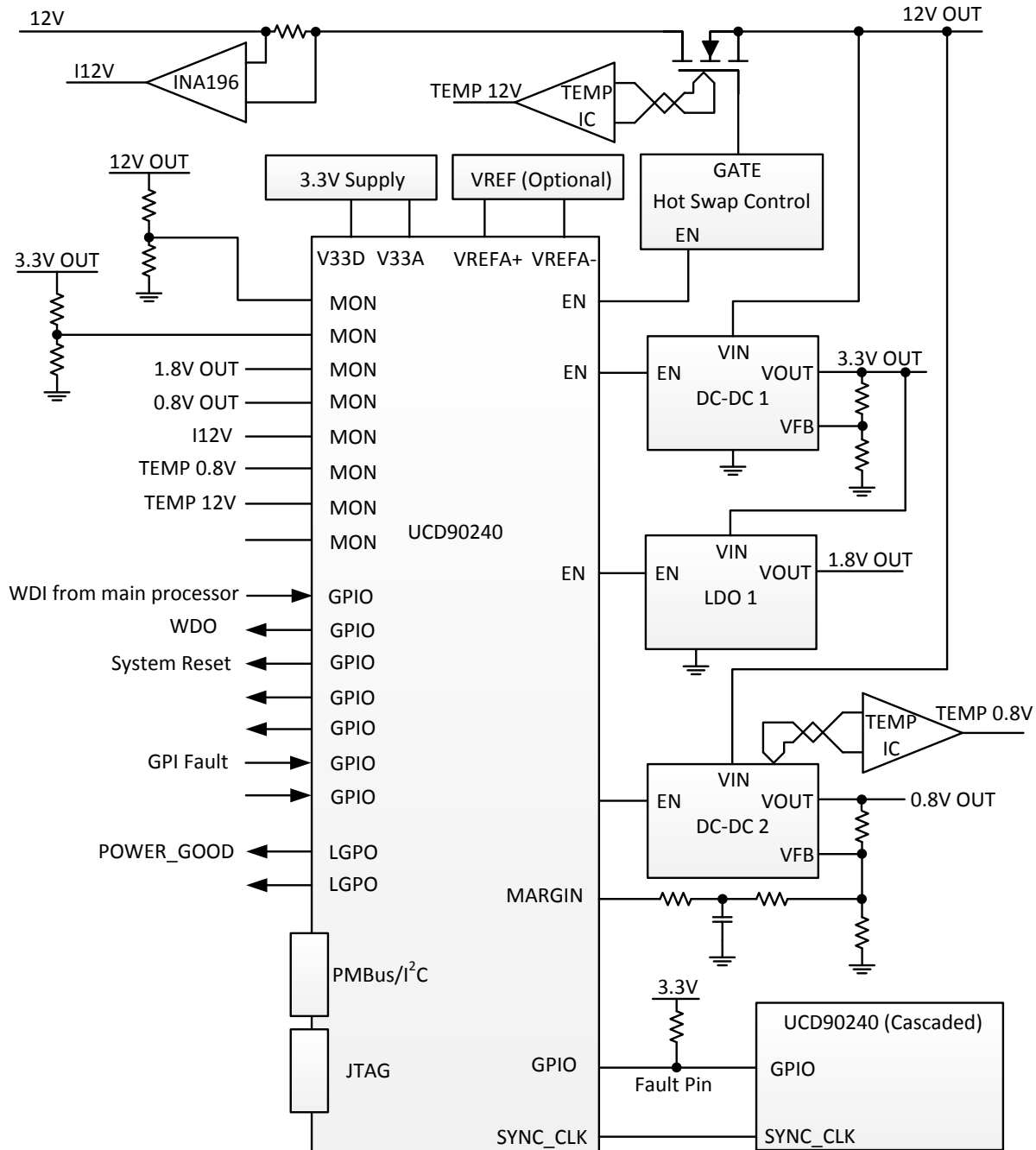

Figure 32. Simplified System Diagram

Typical Application (continued)

8.2.2 Design Requirements

- UCD90240 requires decoupling capacitors on V33D, V33A, BPCAP, and (if applicable) VREFA+ pins. The capacitance values for V33A, BPCAP and VREFA+ are specified in the [Electrical Characteristics](#) section. The following design can be used as a reference:
 - Three 1- μ F X7R ceramic capacitors in parallel with two 0.1- μ F X7R ceramic capacitors for BPCAP decoupling
 - Two 1- μ F X7R ceramic capacitors in parallel with four 0.1- μ F X7R ceramic capacitors and two 0.01- μ F X7R ceramic capacitors for V33D decoupling
 - One 1- μ F X7R ceramic capacitor in parallel with one 0.1- μ F X7R ceramic capacitor and one 0.01- μ F X7R ceramic capacitor for V33A decoupling. A 1- Ω resistor can be placed between V33D and V33A to decouple the noise on V33D from V33A.
 - One 1- μ F X7R ceramic capacitor in parallel with one 0.01- μ F X7R ceramic capacitor for VREFA+ decoupling (if used)

Decoupling capacitors should be placed as close to the device as possible.

- If an application does not use the $\overline{\text{RESET}}$ signal, the $\overline{\text{RESET}}$ pin must be tied to V33D, either by direct connection to the nearest V33D pin (Pin F10), or by a RC circuit as shown in [Figure 33](#). The RC circuit in [Figure 33](#) can be also used to delay reset at power up.

If an application uses the $\overline{\text{RESET}}$ external pin, the trace of the $\overline{\text{RESET}}$ signal must be kept as short as possible. Be sure to place any components connected to the $\overline{\text{RESET}}$ signal as close to the UCD90240 as possible.

- It is recommended to maintain at least 200- Ω resistance between a low-impedance analog input and a MON pin. For example, when monitoring a rail voltage without resistor divider, it is recommended to place a 200- Ω resistor at the MON pin, as shown in [Figure 34](#).

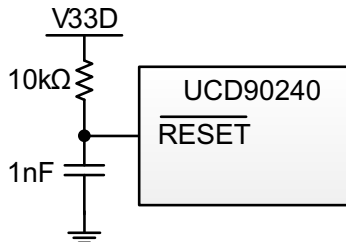

Figure 33. Example of $\overline{\text{RESET}}$ with RC Circuit

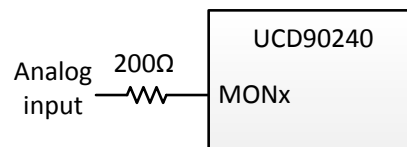

Figure 34. Example of Analog Inputs

8.2.3 Detailed Design Procedure

Fusion GUI can be used to design the device configuration online or offline (with or without a UCD90240 device connected to the computer). In offline mode, Fusion GUI will prompt user to create or open a project file (.xml) at launch. In online mode, Fusion GUI will automatically detect the device on PMBus and extract the configuration data from the device. An USB Interface Adapter EVM (HPA172) from TI is required to connect Fusion GUI to PMBus.

The general design steps include (1) Rail setup, (2) Rail monitoring configuration, (3) GPI configuration, (4) Rail sequence configuration, (5) Fault response configuration, (6) GPO configuration, (7) Margining configuration, (8) Other configurations such as Pin Selected Rail States, Watchdog Timer, System Reset, Sync Clock, Fault Pins, and so on. Details of the steps are described in the Feature Description section, and are self-explanatory in Fusion GUI.

After configuration change(s), the user should click the Write to Hardware button to apply the changes. In online mode, the user can then click the Store RAM to Flash button to permanently store the new configuration into the data flash of the device.

9 Power Supply Recommendations

UCD90240 should be powered by a 3.3-V power supply.

If internal reference is used, V33A is used as ADC reference and is assumed to be exactly 3.3 V. Any input voltage deviation from 3.3 V will introduce an error to ADC reference and thus ADC results. Therefore, the 3.3-V power supply must be tightly regulated and with very small voltage fluctuation (including voltage ripple and voltage deviation caused by load transients).

If external reference is used, the 3.3-V power supply only needs to meet the requirements specified in the [Recommended Operating Conditions](#) section and the [Electrical Characteristics](#) section.

10 Layout

10.1 Layout Guidelines

1. Decoupling capacitors should be placed as close to the device as possible.
2. BPCAP decoupling capacitors should be connected as close as possible to pin D6.
3. MARGIN pins output fast-edge PWM signals. These signals should be routed away from sensitive analog signals. It is a good practice to place R4 and C1 in [Figure 16](#) as close as possible to the MARGIN pin, minimizing the propagation distance of the fast-edge PWM signals on the PCB. R3 can be placed near the power supply feedback node to isolate the feedback node from noise sources on the PCB. If R4 and C1 cannot be located close to the MARGIN pin, add a 20-Ω to 33-Ω series termination resistor located near the MARGIN pin.

10.2 Layout Example

UCD90240 is in a 157-pin BGA package. If UCD90240 is mounted on the top layer, decoupling capacitors can be placed on the bottom layer to make room for top-layer trace routing. The layout example below adopts such a strategy. [Figure 35](#) shows bottom-layer component placement from top-view. In addition to [Figure 35](#), note that:

1. A uniform ground plane should be used to connect DVSS, AVSS, and VREFA– pins.
2. All four BPCAP pins should be connected to a common internal-layer copper area.
3. AVSS and VREFA– pins can be connected to a common internal-layer copper area.

Layout Example (continued)

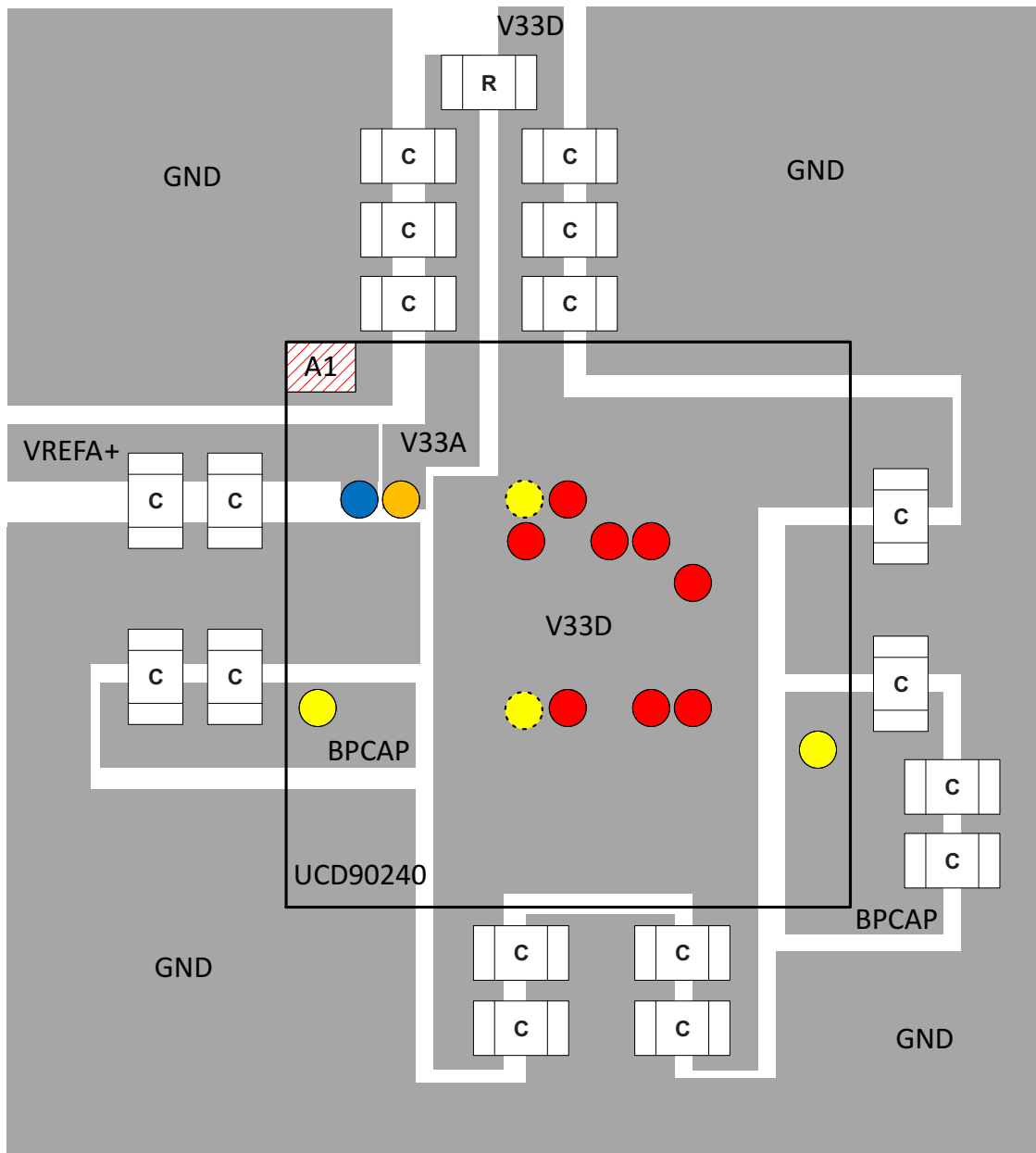

- V33D
- V33A
- BPCAP
- VREFA+

● BPCAP to be connected to decoupling capacitors through an internal-layer copper area

Figure 35. Bottom-layer Component Placement (Top view, UCD90240 is Mounted on Top Layer)

11 Device and Documentation Support

11.1 Trademarks

Fusion Digital Power is a trademark of Texas Instruments.
All other trademarks are the property of their respective owners.

11.2 Electrostatic Discharge Caution



These devices have limited built-in ESD protection. The leads should be shorted together or the device placed in conductive foam during storage or handling to prevent electrostatic damage to the MOS gates.

11.3 Glossary

[SLYZ022](#) — *TI Glossary*.

This glossary lists and explains terms, acronyms, and definitions.

12 Mechanical, Packaging, and Orderable Information

The following pages include mechanical, packaging, and orderable information. This information is the most current data available for the designated devices. This data is subject to change without notice and revision of this document. For browser-based versions of this data sheet, refer to the left-hand navigation.

PACKAGING INFORMATION

Orderable Device	Status (1)	Package Type	Package Drawing	Pins	Package Qty	Eco Plan (2)	Lead/Ball Finish (6)	MSL Peak Temp (3)	Op Temp (°C)	Device Marking (4/5)	Samples
UCD90240ZRBR	ACTIVE	BGA MICROSTAR JUNIOR	ZRB	157	1000	Green (RoHS & no Sb/Br)	SNAGCU	Level-3-260C-168 HR	-40 to 85	UCD90240	Samples
UCD90240ZRBT	ACTIVE	BGA MICROSTAR JUNIOR	ZRB	157	250	TBD	Call TI	Call TI	-40 to 85		Samples

(1) The marketing status values are defined as follows:

ACTIVE: Product device recommended for new designs.

LIFEBUY: TI has announced that the device will be discontinued, and a lifetime-buy period is in effect.

NRND: Not recommended for new designs. Device is in production to support existing customers, but TI does not recommend using this part in a new design.

PREVIEW: Device has been announced but is not in production. Samples may or may not be available.

OBSELETE: TI has discontinued the production of the device.

(2) Eco Plan - The planned eco-friendly classification: Pb-Free (RoHS), Pb-Free (RoHS Exempt), or Green (RoHS & no Sb/Br) - please check <http://www.ti.com/productcontent> for the latest availability information and additional product content details.

TBD: The Pb-Free/Green conversion plan has not been defined.

Pb-Free (RoHS): TI's terms "Lead-Free" or "Pb-Free" mean semiconductor products that are compatible with the current RoHS requirements for all 6 substances, including the requirement that lead not exceed 0.1% by weight in homogeneous materials. Where designed to be soldered at high temperatures, TI Pb-Free products are suitable for use in specified lead-free processes.

Pb-Free (RoHS Exempt): This component has a RoHS exemption for either 1) lead-based flip-chip solder bumps used between the die and package, or 2) lead-based die adhesive used between the die and leadframe. The component is otherwise considered Pb-Free (RoHS compatible) as defined above.

Green (RoHS & no Sb/Br): TI defines "Green" to mean Pb-Free (RoHS compatible), and free of Bromine (Br) and Antimony (Sb) based flame retardants (Br or Sb do not exceed 0.1% by weight in homogeneous material)

(3) MSL, Peak Temp. - The Moisture Sensitivity Level rating according to the JEDEC industry standard classifications, and peak solder temperature.

(4) There may be additional marking, which relates to the logo, the lot trace code information, or the environmental category on the device.

(5) Multiple Device Markings will be inside parentheses. Only one Device Marking contained in parentheses and separated by a "~" will appear on a device. If a line is indented then it is a continuation of the previous line and the two combined represent the entire Device Marking for that device.

(6) Lead/Ball Finish - Orderable Devices may have multiple material finish options. Finish options are separated by a vertical ruled line. Lead/Ball Finish values may wrap to two lines if the finish value exceeds the maximum column width.

Important Information and Disclaimer: The information provided on this page represents TI's knowledge and belief as of the date that it is provided. TI bases its knowledge and belief on information provided by third parties, and makes no representation or warranty as to the accuracy of such information. Efforts are underway to better integrate information from third parties. TI has taken and

continues to take reasonable steps to provide representative and accurate information but may not have conducted destructive testing or chemical analysis on incoming materials and chemicals. TI and TI suppliers consider certain information to be proprietary, and thus CAS numbers and other limited information may not be available for release.

In no event shall TI's liability arising out of such information exceed the total purchase price of the TI part(s) at issue in this document sold by TI to Customer on an annual basis.

ZRB (S-PBGA-N157)

PLASTIC BALL GRID ARRAY

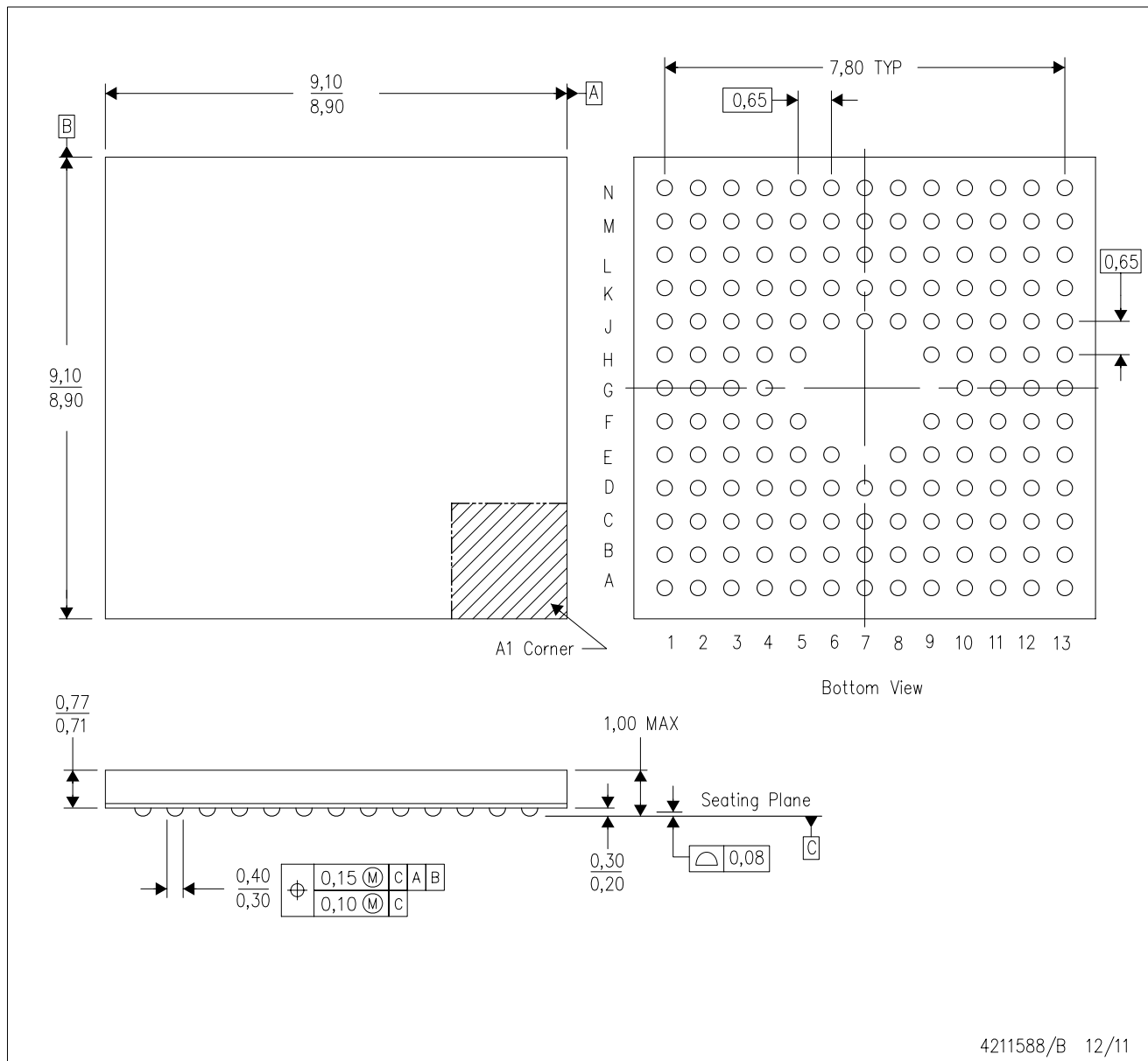

4211588/B 12/11

- NOTES:
- A. All linear dimensions are in millimeters. Dimensioning and tolerancing per ASME Y14.5M-1994.
 - B. This drawing is subject to change without notice.
 - C. MicroStar Junior BGA configuration
 - D. Falls within JEDEC MO-225
 - E. This package is Pb-free.

MicroStar Junior is a trademark of Texas Instruments.

IMPORTANT NOTICE

Texas Instruments Incorporated and its subsidiaries (TI) reserve the right to make corrections, enhancements, improvements and other changes to its semiconductor products and services per JESD46, latest issue, and to discontinue any product or service per JESD48, latest issue. Buyers should obtain the latest relevant information before placing orders and should verify that such information is current and complete. All semiconductor products (also referred to herein as "components") are sold subject to TI's terms and conditions of sale supplied at the time of order acknowledgment.

TI warrants performance of its components to the specifications applicable at the time of sale, in accordance with the warranty in TI's terms and conditions of sale of semiconductor products. Testing and other quality control techniques are used to the extent TI deems necessary to support this warranty. Except where mandated by applicable law, testing of all parameters of each component is not necessarily performed.

TI assumes no liability for applications assistance or the design of Buyers' products. Buyers are responsible for their products and applications using TI components. To minimize the risks associated with Buyers' products and applications, Buyers should provide adequate design and operating safeguards.

TI does not warrant or represent that any license, either express or implied, is granted under any patent right, copyright, mask work right, or other intellectual property right relating to any combination, machine, or process in which TI components or services are used. Information published by TI regarding third-party products or services does not constitute a license to use such products or services or a warranty or endorsement thereof. Use of such information may require a license from a third party under the patents or other intellectual property of the third party, or a license from TI under the patents or other intellectual property of TI.

Reproduction of significant portions of TI information in TI data books or data sheets is permissible only if reproduction is without alteration and is accompanied by all associated warranties, conditions, limitations, and notices. TI is not responsible or liable for such altered documentation. Information of third parties may be subject to additional restrictions.

Resale of TI components or services with statements different from or beyond the parameters stated by TI for that component or service voids all express and any implied warranties for the associated TI component or service and is an unfair and deceptive business practice. TI is not responsible or liable for any such statements.

Buyer acknowledges and agrees that it is solely responsible for compliance with all legal, regulatory and safety-related requirements concerning its products, and any use of TI components in its applications, notwithstanding any applications-related information or support that may be provided by TI. Buyer represents and agrees that it has all the necessary expertise to create and implement safeguards which anticipate dangerous consequences of failures, monitor failures and their consequences, lessen the likelihood of failures that might cause harm and take appropriate remedial actions. Buyer will fully indemnify TI and its representatives against any damages arising out of the use of any TI components in safety-critical applications.

In some cases, TI components may be promoted specifically to facilitate safety-related applications. With such components, TI's goal is to help enable customers to design and create their own end-product solutions that meet applicable functional safety standards and requirements. Nonetheless, such components are subject to these terms.

No TI components are authorized for use in FDA Class III (or similar life-critical medical equipment) unless authorized officers of the parties have executed a special agreement specifically governing such use.

Only those TI components which TI has specifically designated as military grade or "enhanced plastic" are designed and intended for use in military/aerospace applications or environments. Buyer acknowledges and agrees that any military or aerospace use of TI components which have **not** been so designated is solely at the Buyer's risk, and that Buyer is solely responsible for compliance with all legal and regulatory requirements in connection with such use.

TI has specifically designated certain components as meeting ISO/TS16949 requirements, mainly for automotive use. In any case of use of non-designated products, TI will not be responsible for any failure to meet ISO/TS16949.

Products

Audio	www.ti.com/audio
Amplifiers	amplifier.ti.com
Data Converters	dataconverter.ti.com
DLP® Products	www.dlp.com
DSP	dsp.ti.com
Clocks and Timers	www.ti.com/clocks
Interface	interface.ti.com
Logic	logic.ti.com
Power Mgmt	power.ti.com
Microcontrollers	microcontroller.ti.com
RFID	www.ti-rfid.com
OMAP Applications Processors	www.ti.com/omap
Wireless Connectivity	www.ti.com/wirelessconnectivity

Applications

Automotive and Transportation	www.ti.com/automotive
Communications and Telecom	www.ti.com/communications
Computers and Peripherals	www.ti.com/computers
Consumer Electronics	www.ti.com/consumer-apps
Energy and Lighting	www.ti.com/energy
Industrial	www.ti.com/industrial
Medical	www.ti.com/medical
Security	www.ti.com/security
Space, Avionics and Defense	www.ti.com/space-avionics-defense
Video and Imaging	www.ti.com/video

TI E2E Community

e2e.ti.com