

Optocoupler, Phototriac Output, 400 V V_{DRM}

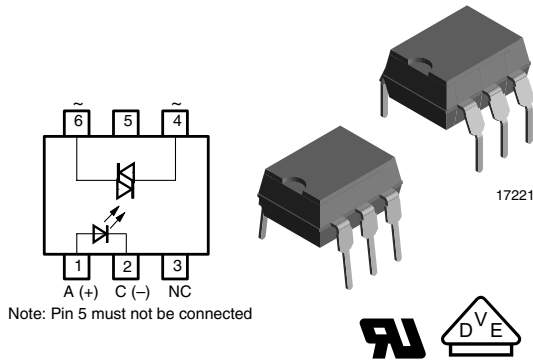

Note: Pin 5 must not be connected

DESCRIPTION

The K3020P/, 3020PG series consists of a photo-transistor optically coupled to a gallium arsenide infrared-emitting diode in a 6-lead plastic dual inline package

VDE STANDARDS

These couplers perform safety functions according to the following equipment standards:

- **DIN EN 60747-5-5 (VDE 0884)**
Optocoupler for electrical safety requirements
- **IEC 60950/EN 60950**
Office machines (applied for reinforced isolation for mains voltage $\leq 400 V_{RMS}$)
- **VDE 0804**
Telecommunication apparatus and data processing
- **IEC 60065**
Safety for mains-operated electronic and related household apparatus

AGENCY APPROVALS

- UL1577, file no. E76222 system code C, double protection
- BSI: BS EN 41003, BS EN 60065 (BS 415), BS EN 60950 (BS 7002), certificate number 7081 and 7402
- DIN EN 60747-5-5 (VDE 0884)
- FIMKO (SETI): EN 60950, certificate no. 12398

FEATURES

- Isolation materials according to UL 94-VO
- Pollution degree 2 (DIN/VDE 0110 resp. IEC 60664)
- Climatic classification 55/100/21 (IEC 60068 part 1)
- Special construction: therefore, extra low coupling capacity of typical 0.2 pF, high common mode rejection
- I_{FT} offered in 4 groups
- Rated impulse voltage (transient overvoltage) $V_{IOTM} = 6 \text{ kV peak}$
- Isolation test voltage (partial discharge test voltage) $V_{pd} = 1.6 \text{ kV}$
- Rated isolation voltage (RMS includes DC) $V_{IOWM} = 600 V_{RMS}$ (848 V peak)
- Rated recurring peak voltage (repetitive) $V_{IORM} = 600 V_{RMS}$
- Thickness through insulation $\geq 0.75 \text{ mm}$
- Creepage current resistance according to VDE 0303/IEC 60112 comparative tracking index: CTI = 275
- Lead (Pb)-free component
- Component in accordance to RoHS 2002/95/EC and WEEE 2002/96/EC



RoHS COMPLIANT

APPLICATIONS

- Monitors
- Air conditioners
- Line switches
- Solid state relay
- Microwave
- Circuits for safe protective separation against electrical shock according to safety class II (reinforced isolation):
 - for appl. class I - IV at mains voltage $\leq 300 \text{ V}$
 - for appl. class I - III at mains voltage $\leq 600 \text{ V}$ according to DIN EN 60747-5-5 (VDE 0884)

ORDER INFORMATION	
PART	REMARKS
K3020P	$I_{FT} < 30 \text{ mA}$, $V_{DRM} = 400 \text{ V}$, DIP-6
K3021P	$I_{FT} < 15 \text{ mA}$, $V_{DRM} = 400 \text{ V}$, DIP-6
K3022P	$I_{FT} < 10 \text{ mA}$, $V_{DRM} = 400 \text{ V}$, DIP-6
K3023P	$I_{FT} < 5 \text{ mA}$, $V_{DRM} = 400 \text{ V}$, DIP-6
K3036P	$I_{FT} < 3.6 \text{ mA}$, $V_{DRM} = 400 \text{ V}$, DIP-6
K3020PG	$I_{FT} < 30 \text{ mA}$, $V_{DRM} = 400 \text{ V}$, DIP-6 400 mil
K3021PG	$I_{FT} < 15 \text{ mA}$, $V_{DRM} = 400 \text{ V}$, DIP-6 400 mil
K3022PG	$I_{FT} < 10 \text{ mA}$, $V_{DRM} = 400 \text{ V}$, DIP-6 400 mil
K3023PG	$I_{FT} < 5 \text{ mA}$, $V_{DRM} = 400 \text{ V}$, DIP-6 400 mil
K3036PG	$I_{FT} < 3.6 \text{ mA}$, $V_{DRM} = 400 \text{ V}$, DIP-6 400 mil

Note

G = leadform 10.16 mm; G is not marked on the body

K3020P, K3020PG Series



Vishay Semiconductors

Optocoupler, Phototriac
Output, 400 V V_{DRM}

ABSOLUTE MAXIMUM RATINGS (1)				
PARAMETER	TEST CONDITION	SYMBOL	VALUE	UNIT
INPUT				
Reverse voltage		V_R	5	V
Forward current		I_F	80	mA
Forward surge current	$t_p \leq 10 \mu s$	I_{FSM}	3	A
Power dissipation		P_{diss}	100	mW
Junction temperature		T_j	100	°C
OUTPUT				
Off state output terminal voltage		V_{DRM}	400	V
On state RMS current		I_{TRM}	100	mA
Peak surge current, non-repetitive	$t_p \leq 10 ms$	I_{TSM}	1.5	A
Power dissipation		P_{diss}	300	mW
Junction temperature		T_j	100	°C
COUPLER				
Isolation test voltage (RMS)		V_{ISO}	3750	V_{RMS}
Total power dissipation		P_{tot}	350	mW
Ambient temperature range		T_{amb}	- 40 to + 85	°C
Storage temperature range		T_{stg}	- 55 to + 100	°C
Soldering temperature (2)	2 mm from case, $t \leq 10 s$	T_{sld}	260	°C

Notes

(1) $T_{amb} = 25 \text{ }^\circ\text{C}$, unless otherwise specified.

Stresses in excess of the absolute maximum ratings can cause permanent damage to the device. Functional operation of the device is not implied at these or any other conditions in excess of those given in the operational sections of this document. Exposure to absolute maximum ratings for extended periods of the time can adversely affect reliability.

(2) Refer to wave profile for soldering conditions for through hole devices.

ELECTRICAL CHARACTERISTICS (1)							
PARAMETER	TEST CONDITION	PART	SYMBOL	MIN.	TYP.	MAX.	UNIT
INPUT							
Forward voltage	$I_F = 50 \text{ mA}$		V_F		1.25	1.6	V
Junction capacitance	$V_R = 0, f = 1 \text{ MHz}$		C_j		50		pF
OUTPUT							
Forward peak off-state voltage (repetitive)	$I_{RDM} = 100 \text{ nA}$		$V_{DRM}^{(2)}$	400			V
Peak on-state voltage	$I_{TM} = 100 \text{ mA}$		V_{TM}		1.5	3	V
Critical rate of rise of off-state voltage	$I_{FT} = 0, I_{FT} = 30 \text{ mA}$,		dV/dt_{cr}		10		V/ μs
			dV/dt_{crq}	0.1	0.2		V/ μs
COUPLER (3)							
Emitting diode trigger current	$V_S = 3 \text{ V}, R_L = 150 \Omega$	K3020P	I_{FT}		15	30	mA
		K3020PG	I_{FT}		15	30	mA
		K3021P	I_{FT}		8	15	mA
		K3021PG	I_{FT}		8	15	mA
		K3022P	I_{FT}		5	10	mA
		K3022PG	I_{FT}		5	10	mA
		K3023P	I_{FT}		2	5	mA
		K3023PG	I_{FT}		2	5	mA
		K3036P	I_{FT}		2	3.6	mA
K3036PG	I_{FT}		2	3.6	mA		
Holding current	$I_F = 10 \text{ mA}, V_S \geq 3 \text{ V}$		I_H		100		μA

Notes

(1) $T_{amb} = 25 \text{ }^\circ\text{C}$, unless otherwise specified.

Minimum and maximum values are testing requirements. Typical values are characteristics of the device and are the result of engineering evaluation. Typical values are for information only and are not part of the testing requirements.

(2) Test voltage must be applied within dV/dt ratings.

(3) I_{FT} is defined as a minimum trigger current.

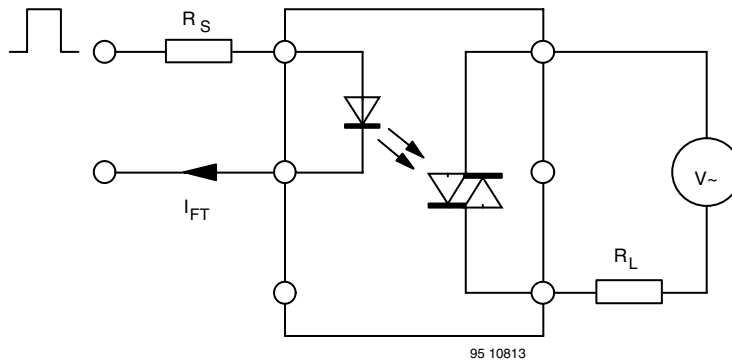

Test condition:
 dV/dt_{cr}
 $V_S = 2/3 V_{DRM}$
 (sine wave)
 $R_L = 33\text{ k}$
 dV/dt_{crq}
 $V_{eff} = 30\text{ V}$
 (sine wave)
 $R_L = 2\text{ k}\Omega$

Fig. 1 - Test Circuit for dV/dt_{cr} and dV/dt_{crq}

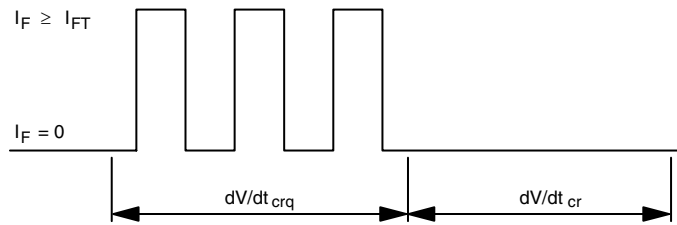

dV/dt_{cr} Highest value of the "rate of rise of off-state voltage" which does not cause any switching from the off state to the on state
 dV/dt_{crq} Highest value of the "rate of rise of communicating voltage" which does not switch on the device again, after the voltage has decreased to zero and the trigger current is switched from I_{FT} to zero

95 10814

Fig. 2

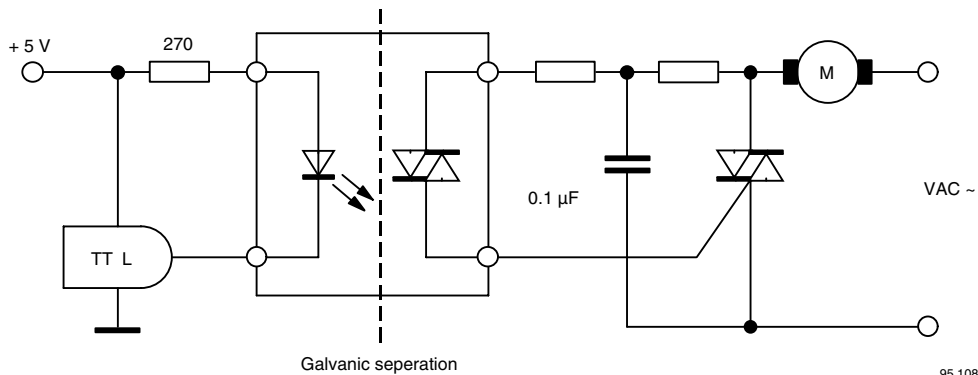

Fig. 3 - Motor Control Circuit

95 10815

MAXIMUM SAFETY RATINGS						
PARAMETER	TEST CONDITION	SYMBOL	MIN.	TYP.	MAX.	UNIT
INPUT						
Forward current		I_F			130	mA
OUTPUT						
Power dissipation		P_{diss}			600	mW
COUPLER						
Rated impulse voltage		V_{IOTM}			6	kV
Safety temperature		T_{si}			150	$^{\circ}\text{C}$

Note

According to DIN EN 60747-5-5 (see figure 4). This optocoupler is suitable for safe electrical isolation only within the safety ratings. Compliance with the safety ratings shall be ensured by means of suitable protective circuits.

INSULATION RATED PARAMETERS						
PARAMETER	TEST CONDITION	SYMBOL	MIN.	TYP.	MAX.	UNIT
Partial discharge test voltage - routine test	100 %, $t_{test} = 1$ s	V_{pd}	1.6			kV
Partial discharge test voltage - lot test (sample test)	$t_{Tr} = 60$ s, $t_{test} = 10$ s, (see figure 5)	V_{IOTM}	6			kV
		V_{pd}	1.3			kV
Insulation resistance	$V_{IO} = 500$ V	R_{IO}	10^{12}			Ω
	$V_{IO} = 500$ V, $T_{amb} = 100$ °C	R_{IO}	10^{11}			Ω
	$V_{IO} = 500$ V, $T_{amb} = 150$ °C (construction test only)	R_{IO}	10^9			Ω

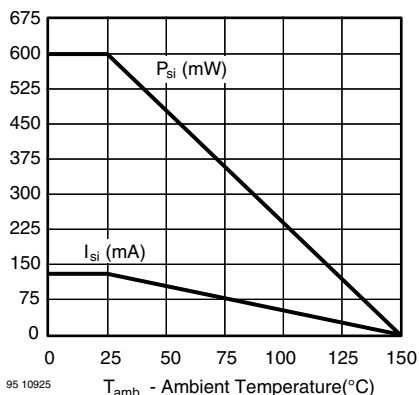

Fig. 4 - Derating Diagram

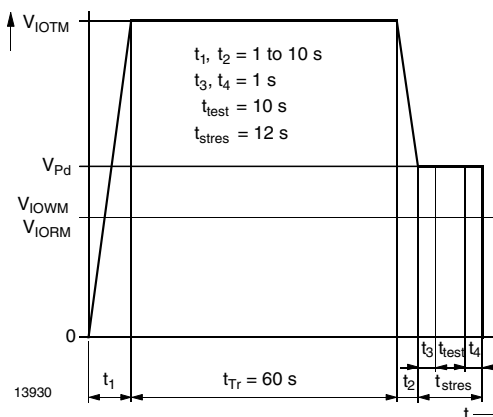

Fig. 5 - Test Pulse Diagram for Sample Test according to DIN EN 60747-5-5/DIN EN 60747-; IEC60747

TYPICAL CHARACTERISTICS

$T_{amb} = 25$ °C, unless otherwise specified

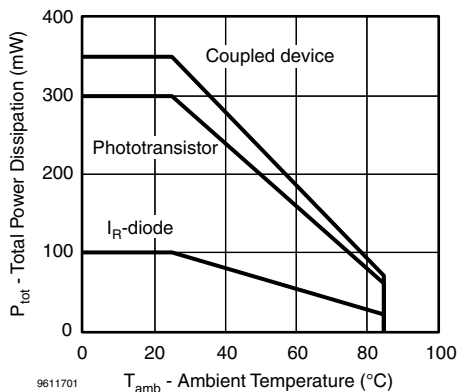

Fig. 6 - Total Power Dissipation vs. Ambient Temperature

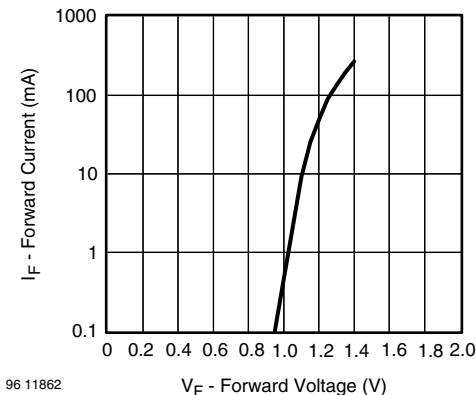

Fig. 7 - Forward Current vs. Forward Voltage

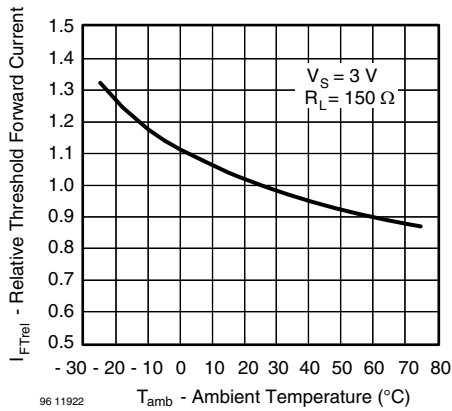

Fig. 8 - Relative Threshold Forward Current vs. Ambient Temperature

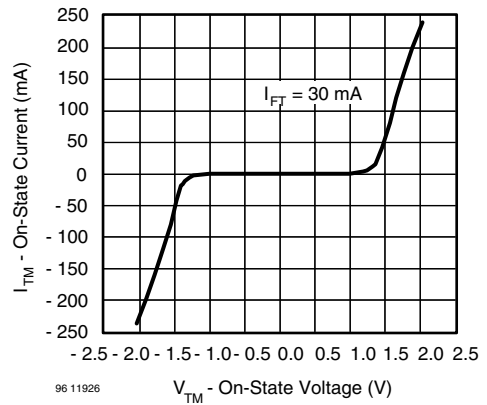

Fig. 11 - On-State Current vs. Ambient Temperature

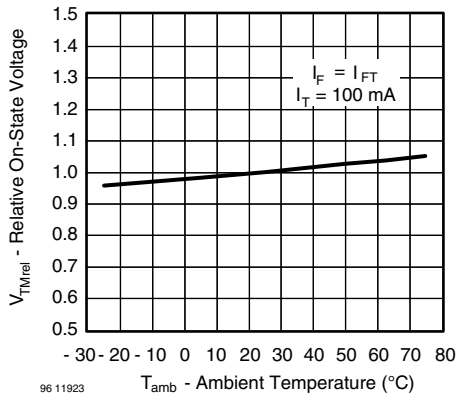

Fig. 9 - Relativ On-State Current vs. Ambient Temperature

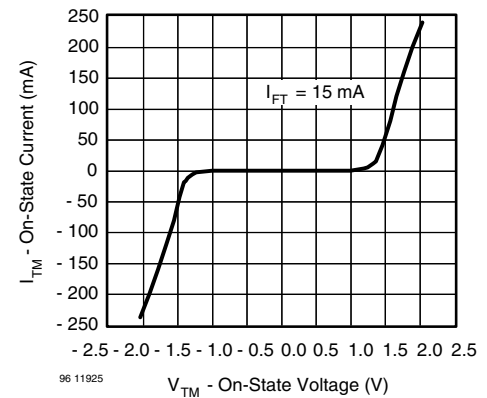

Fig. 12 - On-State Current vs. Ambient Temperature

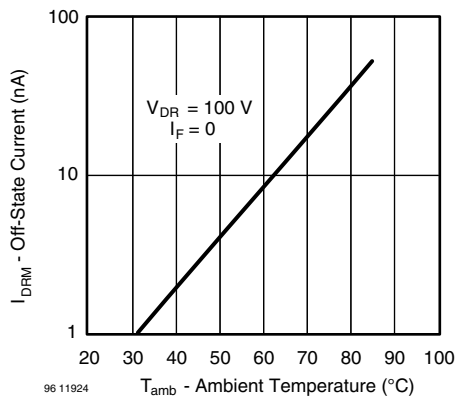

Fig. 10 - Off-State Current vs. Ambient Temperature

K3020P, K3020PG Series

Vishay Semiconductors

Optocoupler, Phototriac
Output, 400 V V_{DRM}



PACKAGE DIMENSIONS in millimeters

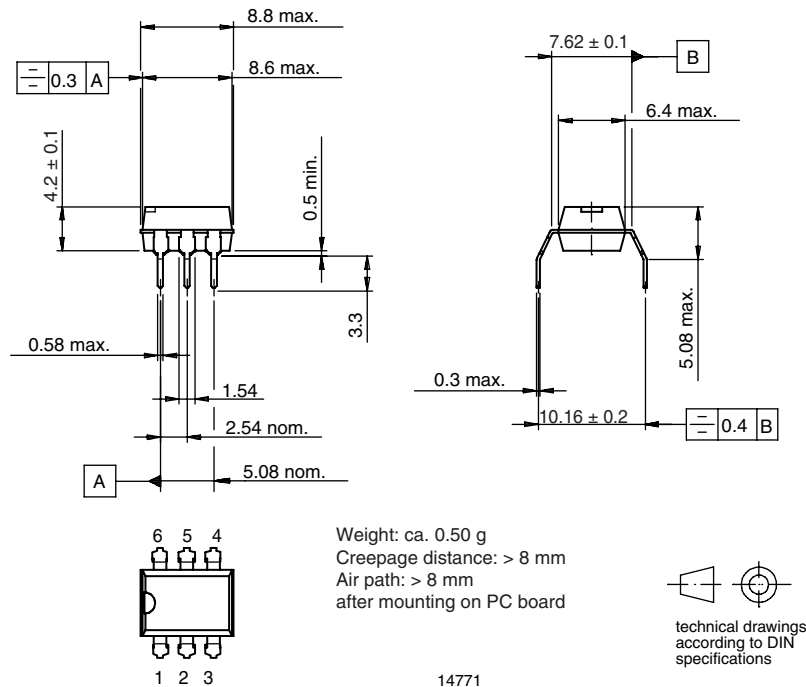
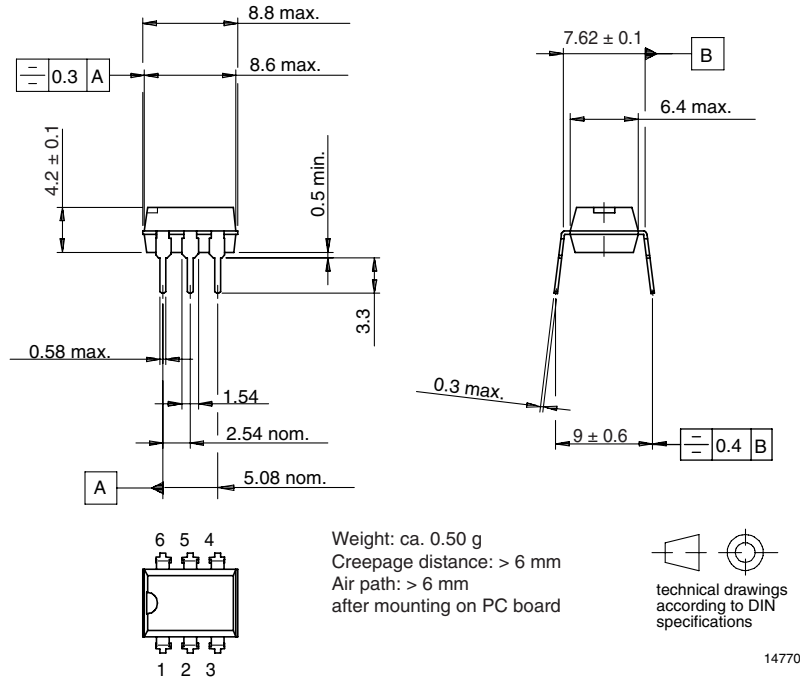



OZONE DEPLETING SUBSTANCES POLICY STATEMENT

It is the policy of Vishay Semiconductor GmbH to

1. Meet all present and future national and international statutory requirements.
2. Regularly and continuously improve the performance of our products, processes, distribution and operating systems with respect to their impact on the health and safety of our employees and the public, as well as their impact on the environment.

It is particular concern to control or eliminate releases of those substances into the atmosphere which are known as ozone depleting substances (ODSs).

The Montreal Protocol (1987) and its London Amendments (1990) intend to severely restrict the use of ODSs and forbid their use within the next ten years. Various national and international initiatives are pressing for an earlier ban on these substances.

Vishay Semiconductor GmbH has been able to use its policy of continuous improvements to eliminate the use of ODSs listed in the following documents.

1. Annex A, B and list of transitional substances of the Montreal Protocol and the London Amendments respectively.
2. Class I and II ozone depleting substances in the Clean Air Act Amendments of 1990 by the Environmental Protection Agency (EPA) in the USA.
3. Council Decision 88/540/EEC and 91/690/EEC Annex A, B and C (transitional substances) respectively.

Vishay Semiconductor GmbH can certify that our semiconductors are not manufactured with ozone depleting substances and do not contain such substances.

We reserve the right to make changes to improve technical design
and may do so without further notice.

Parameters can vary in different applications. All operating parameters must be validated for each customer application by the customer. Should the buyer use Vishay Semiconductors products for any unintended or unauthorized application, the buyer shall indemnify Vishay Semiconductors against all claims, costs, damages, and expenses, arising out of, directly or indirectly, any claim of personal damage, injury or death associated with such unintended or unauthorized use.

Vishay Semiconductor GmbH, P.O.B. 3535, D-74025 Heilbronn, Germany



Disclaimer

All product specifications and data are subject to change without notice.

Vishay Intertechnology, Inc., its affiliates, agents, and employees, and all persons acting on its or their behalf (collectively, "Vishay"), disclaim any and all liability for any errors, inaccuracies or incompleteness contained herein or in any other disclosure relating to any product.

Vishay disclaims any and all liability arising out of the use or application of any product described herein or of any information provided herein to the maximum extent permitted by law. The product specifications do not expand or otherwise modify Vishay's terms and conditions of purchase, including but not limited to the warranty expressed therein, which apply to these products.

No license, express or implied, by estoppel or otherwise, to any intellectual property rights is granted by this document or by any conduct of Vishay.

The products shown herein are not designed for use in medical, life-saving, or life-sustaining applications unless otherwise expressly indicated. Customers using or selling Vishay products not expressly indicated for use in such applications do so entirely at their own risk and agree to fully indemnify Vishay for any damages arising or resulting from such use or sale. Please contact authorized Vishay personnel to obtain written terms and conditions regarding products designed for such applications.

Product names and markings noted herein may be trademarks of their respective owners.