

Optocoupler, Phototransistor Output, High Temperature, 110 °C, Rated

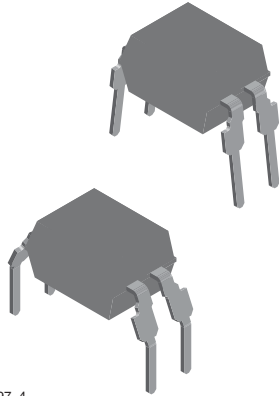

17197_4

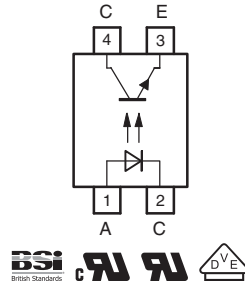

DESCRIPTION

The TCET1110, TCET1110G consists of a phototransistor optically coupled to a gallium arsenide infrared-emitting diode in a 4 pin plastic dual inline package.

APPLICATIONS

Circuits for safe protective separation against electrical shock according to safety class II (reinforced isolation):

- for appl. class I to IV at mains voltage ≤ 300 V
- for appl. class I to III at mains voltage ≤ 600 V according to DIN EN 60747-5-2 (VDE 0884), suitable for:
 - Switch-mode power supplies
 - Line receiver
 - Computer peripheral interface
 - Microprocessor system interface

FEATURES

- CTR offered in 9 groups
- Isolation materials according to UL 94 V-O
- Pollution degree 2 (DIN/VDE 0110/resp. IEC 60664)
- Climatic classification 55/100/21 (IEC 60068 part 1)
- Special construction: therefore, extra low coupling capacity of typical 0.2 pF, high common mode rejection
- Low temperature coefficient of CTR
- Temperature range - 40 °C to + 110 °C
- Rated impulse voltage (transient overvoltage) $V_{IOTM} = 6$ kV_{peak}
- Isolation test voltage (partial discharge test voltage) $V_{pd} = 1.6$ kV
- Rated isolation voltage (RMS includes DC) $V_{IOWM} = 600$ V_{RMS}
- Rated recurring peak voltage (repetitive) $V_{IORM} = 850$ V_{peak}
- Creepage current resistance according to VDE 0303/IEC 60112 comparative tracking index: CTI ≥ 175
- Thickness through insulation ≥ 4 mm
- External creepage distance > 8 mm
- Compliant to RoHS Directive 2002/95/EC and in accordance to WEEE 2002/96/EC

RoHS
COMPLIANT

AGENCY APPROVALS

- UL1577, file no. E52744, double protection
- BSI: EN 60065:2002, EN 60950-1:2006
- DIN EN 60747-5-2 (VDE 0884)
- FIMKO

ORDERING INFORMATION

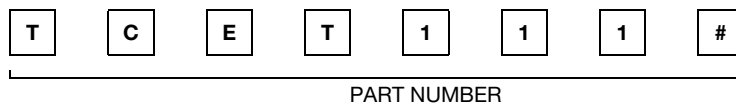
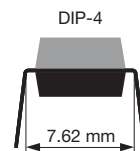
 #
PACKAGE
OPTION

AGENCY CERTIFIED/PACKAGE	CTR (%)			
	5 mA	10 mA	10 mA	10 mA
UL, VDE, BSI, FIMKO	50 to 600	63 to 125	100 to 200	160 to 320
DIP-4	TCET1110	TCET1112	TCET1113	TCET1114
DIP-4, 400 mil	-	-	TCET1113G	TCET1114G



ABSOLUTE MAXIMUM RATINGS (T _{amb} = 25 °C, unless otherwise specified)				
PARAMETER	TEST CONDITION	SYMBOL	VALUE	UNIT
INPUT				
Reverse voltage		V _R	6	V
Forward current		I _F	60	mA
Forward surge current	t _p ≤ 10 μs	I _{FSM}	1.5	A
OUTPUT				
Collector emitter voltage		V _{CEO}	70	V
Emitter collector voltage		V _{ECO}	7	V
Collector current		I _C	50	mA
Collector peak current	t _p /T = 0.5, t _p ≤ 10 ms	I _{CM}	100	mA
COUPLER				
Isolation test voltage (RMS)	t = 1 s	V _{ISO}	5000	V _{RMS}
Operating ambient temperature range		T _{amb}	- 40 to + 110	°C
Storage temperature range		T _{stg}	- 55 to + 125	°C
Soldering temperature ⁽¹⁾	2 mm from case, ≤ 10 s	T _{slid}	260	°C

Notes

- Stresses in excess of the absolute maximum ratings can cause permanent damage to the device. Functional operation of the device is not implied at these or any other conditions in excess of those given in the operational sections of this document. Exposure to absolute maximum ratings for extended periods of the time can adversely affect reliability.
- ⁽¹⁾ Refer to wave profile for soldering conditions for through hole devices (DIP).

THERMAL CHARACTERISTICS				
PARAMETER	SYMBOL	VALUE	UNIT	
LED power dissipation	P _{diss}	70	mW	
Output power dissipation	P _{diss}	70	mW	
Maximum LED junction temperature	T _{Jmax.}	125	°C	
Maximum output die junction temperature	T _{Jmax.}	125	°C	
Thermal resistance, junction emitter to board	θ _{EB}	173	°C/W	
Thermal resistance, junction emitter to case	θ _{EC}	149	°C/W	
Thermal resistance, junction detector to board	θ _{DB}	111	°C/W	
Thermal resistance, junction detector to case	θ _{DC}	127	°C/W	
Thermal resistance, junction emitter to junction detector	θ _{ED}	173	°C/W	
Thermal resistance, board to ambient ⁽¹⁾	θ _{BA}	197	°C/W	
Thermal resistance, case to ambient ⁽¹⁾	θ _{CA}	4041	°C/W	

Notes

- The thermal model is represented in the thermal network below. Each resistance value given in this model can be used to calculate the temperatures at each node for a given operating condition. The thermal resistance from board to ambient will be dependent on the type of PCB, layout and thickness of copper traces. For a detailed explanation of the thermal model, please reference Vishay’s “Thermal Characteristics of Optocouplers” application note.
- ⁽¹⁾ For 2 layer FR4 board (4" x 3" x 0.062").



ELECTRICAL CHARACTERISTICS ($T_{amb} = 25\text{ }^{\circ}\text{C}$, unless otherwise specified)						
PARAMETER	TEST CONDITION	SYMBOL	MIN.	TYP.	MAX.	UNIT
INPUT						
Forward voltage	$I_F = 50\text{ mA}$	V_F		1.25	1.6	V
Junction capacitance	$V_R = 0, f = 1\text{ MHz}$	C_j		50		pF
OUTPUT						
Collector emitter voltage	$I_C = 1\text{ mA}$	V_{CEO}	70			V
Emitter collector voltage	$I_E = 100\text{ }\mu\text{A}$	V_{ECO}	7			V
Collector emitter cut-off current	$V_{CE} = 20\text{ V}, I_F = 0\text{ A}$	I_{CEO}		10	100	nA
COUPLER						
Collector emitter saturation voltage	$I_F = 10\text{ mA}, I_C = 1\text{ mA}$	V_{CEsat}			0.3	V
Cut-off frequency	$V_{CE} = 5\text{ V}, I_F = 10\text{ mA}, R_L = 100\text{ }\Omega$	f_c		110		kHz
Coupling capacitance	$f = 1\text{ MHz}$	C_k		0.6		pF

Note

- (1) Minimum and maximum values are testing requirements. Typical values are characteristics of the device and are the result of engineering evaluation. Typical values are for information only and are not part of the testing requirements.

CURRENT TRANSFER RATIO ($T_{amb} = 25\text{ }^{\circ}\text{C}$, unless otherwise specified)							
PARAMETER	TEST CONDITION	PART	SYMBOL	MIN.	TYP.	MAX.	UNIT
I_C/I_F	$V_{CE} = 5\text{ V}, I_F = 1\text{ mA}$	TCET1112, TCET1112G	CTR	22	45		%
		TCET1113, TCET1113G	CTR	34	70		%
		TCET1114, TCET1114G	CTR	56	90		%
	$V_{CE} = 5\text{ V}, I_F = 5\text{ mA}$	TCET1110, TCET1110G	CTR	50		600	%
	$V_{CE} = 5\text{ V}, I_F = 10\text{ mA}$	TCET1112, TCET1112G	CTR	63		125	%
		TCET1113, TCET1113G	CTR	100		200	%
		TCET1114, TCET1114G	CTR	160		320	%

SAFETY AND INSULATION RATED PARAMETERS						
PARAMETER	TEST CONDITION	SYMBOL	MIN.	TYP.	MAX.	UNIT
Partial discharge test voltage - routine test	100 %, $t_{test} = 1\text{ s}$	V_{pd}	1.6			kV
Partial discharge test voltage - lot test (sample test)	$t_{Tr} = 60\text{ s}, t_{test} = 10\text{ s},$ (see figure 2)	V_{IOTM}	8			kV
		V_{pd}	1.3			kV
Insulation resistance	$V_{IO} = 500\text{ V}$	R_{IO}	10^{12}			Ω
	$V_{IO} = 500\text{ V}, T_{amb} = 100\text{ }^{\circ}\text{C}$	R_{IO}	10^{11}			Ω
	$V_{IO} = 500\text{ V}, T_{amb} = 150\text{ }^{\circ}\text{C}$ (construction test only)	R_{IO}	10^9			Ω
Forward current		I_{si}			130	mA
Power dissipation		P_{so}			265	mW
Rated impulse voltage		V_{IOTM}			6	kV
Safety temperature		T_{si}			150	$^{\circ}\text{C}$

Note

- According to DIN EN 60747-5-2 (see figure 2). This optocoupler is suitable for safe electrical isolation only within the safety ratings. Compliance with the safety ratings shall be ensured by means of suitable protective circuits.

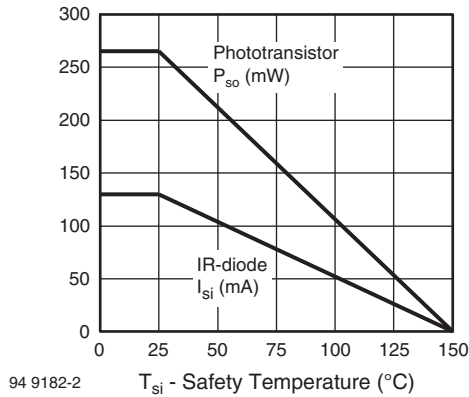

Fig. 1 - Derating Diagram

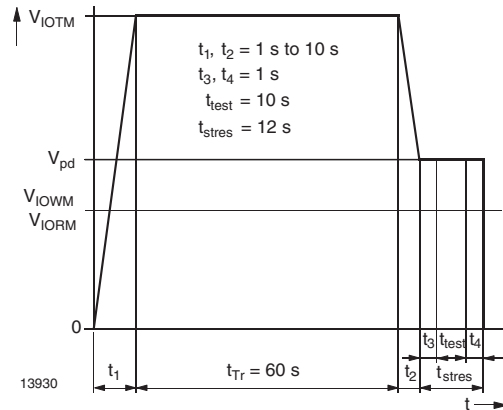

Fig. 2 - Test Pulse Diagram for Sample Test according to DIN EN 60747-5-2 (VDE 0884)/IEC 60747-5-5

SWITCHING CHARACTERISTICS ($T_{\text{amb}} = 25 \text{ }^\circ\text{C}$, unless otherwise specified)						
PARAMETER	TEST CONDITION	SYMBOL	MIN.	TYP.	MAX.	UNIT
Delay time	$V_S = 5 \text{ V}$, $I_C = 2 \text{ mA}$, $R_L = 100 \text{ } \Omega$, (see figure 3)	t_d		3		μs
Rise time	$V_S = 5 \text{ V}$, $I_C = 2 \text{ mA}$, $R_L = 100 \text{ } \Omega$, (see figure 3)	t_r		3		μs
Fall time	$V_S = 5 \text{ V}$, $I_C = 2 \text{ mA}$, $R_L = 100 \text{ } \Omega$, (see figure 3)	t_f		4.7		μs
Storage time	$V_S = 5 \text{ V}$, $I_C = 2 \text{ mA}$, $R_L = 100 \text{ } \Omega$, (see figure 3)	t_s		0.3		μs
Turn-on time	$V_S = 5 \text{ V}$, $I_C = 2 \text{ mA}$, $R_L = 100 \text{ } \Omega$, (see figure 3)	t_{on}		6		μs
Turn-off time	$V_S = 5 \text{ V}$, $I_C = 2 \text{ mA}$, $R_L = 100 \text{ } \Omega$, (see figure 3)	t_{off}		5		μs
Turn-on time	$V_S = 5 \text{ V}$, $I_F = 10 \text{ mA}$, $R_L = 1 \text{ k}\Omega$, (see figure 4)	t_{on}		9		μs
Turn-off time	$V_S = 5 \text{ V}$, $I_F = 10 \text{ mA}$, $R_L = 1 \text{ k}\Omega$, (see figure 4)	t_{off}		10		μs

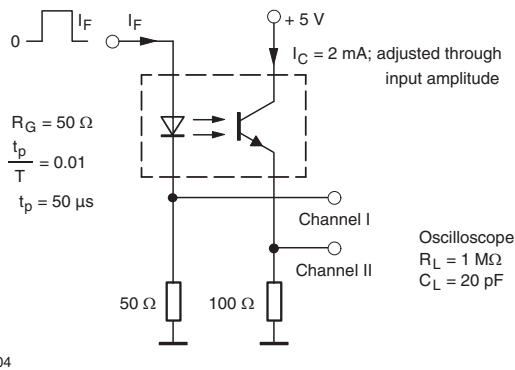

Fig. 3 - Test Circuit, Non-Saturated Operation

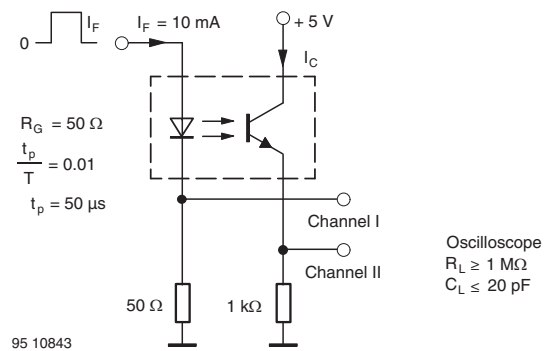

Fig. 4 - Test Circuit, Saturated Operation

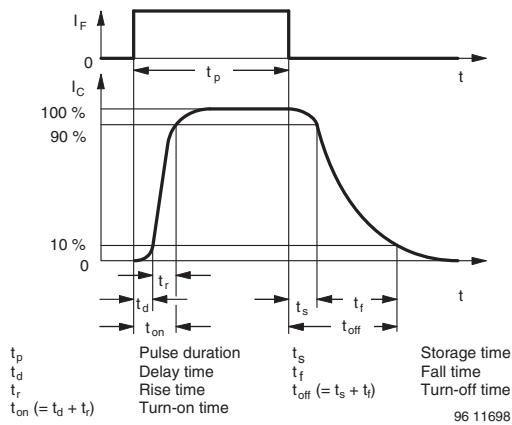

Fig. 5 - Switching Times

TYPICAL CHARACTERISTICS ($T_{amb} = 25\text{ }^\circ\text{C}$, unless otherwise specified)

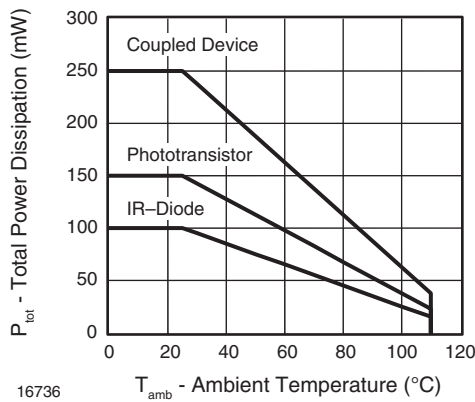

Fig. 6 - Total Power Dissipation vs. Ambient Temperature

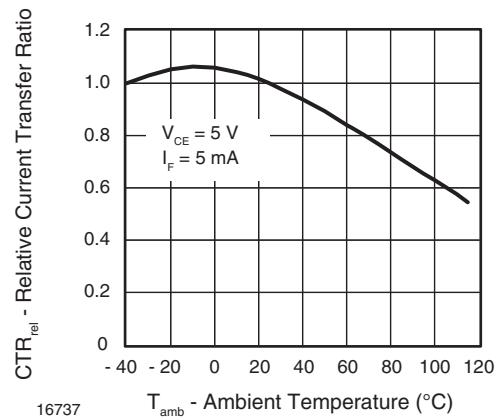

Fig. 8 - Relative Current Transfer Ratio vs. Ambient Temperature

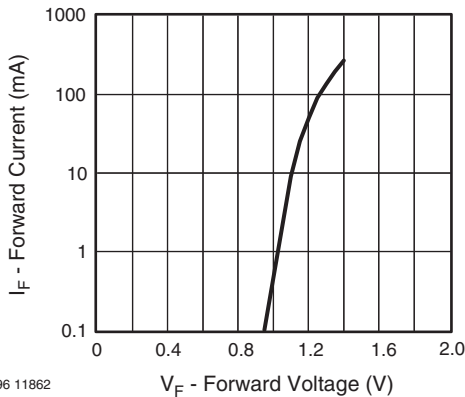

Fig. 7 - Forward Current vs. Forward Voltage

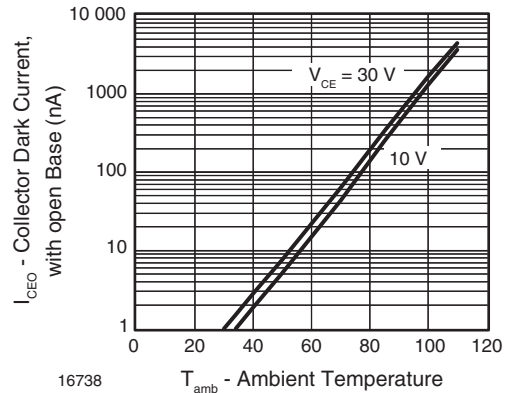
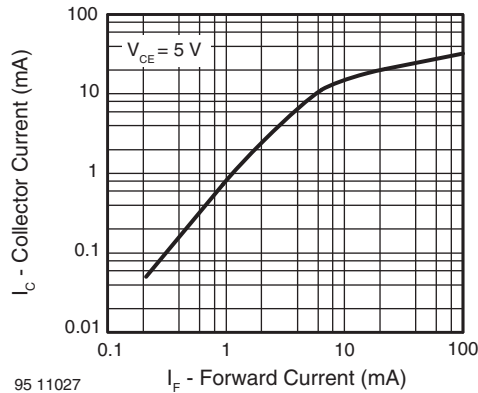
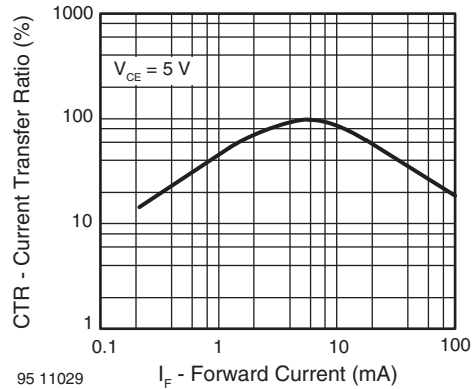

Fig. 9 - Collector Dark Current vs. Ambient Temperature



95 11027

Fig. 10 - Collector Current vs. Forward Current



95 11029

Fig. 13 - Current Transfer Ratio vs. Forward Current

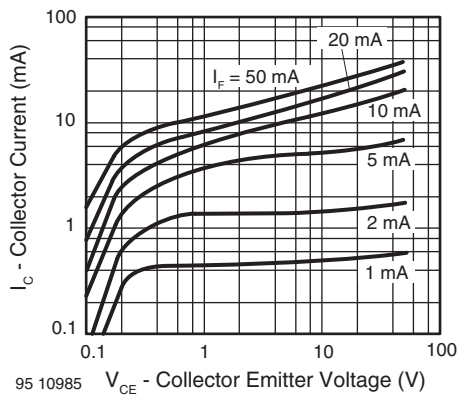

95 10985

Fig. 11 - Collector Current vs. Collector Emitter Voltage

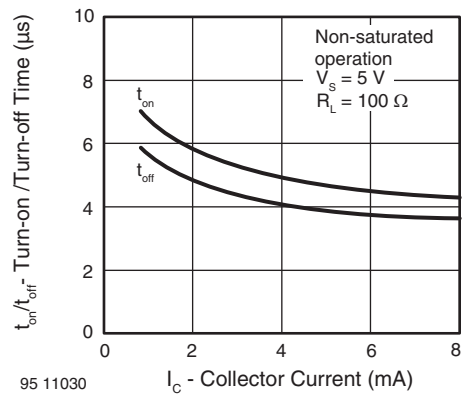

95 11030

Fig. 14 - Turn-on/off Time vs. Collector Current

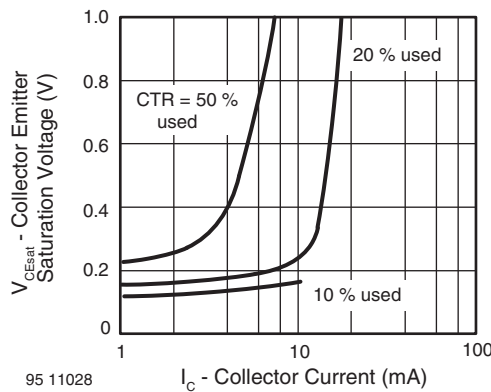

95 11028

Fig. 12 - Collector Emitter Saturation Voltage vs. Collector Current

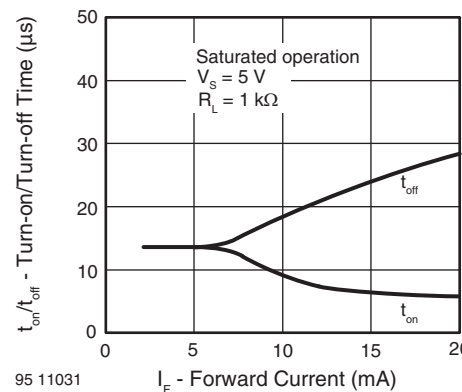

95 11031

Fig. 15 - Turn-on/off Time vs. Forward Current



PACKAGE DIMENSIONS in millimeters

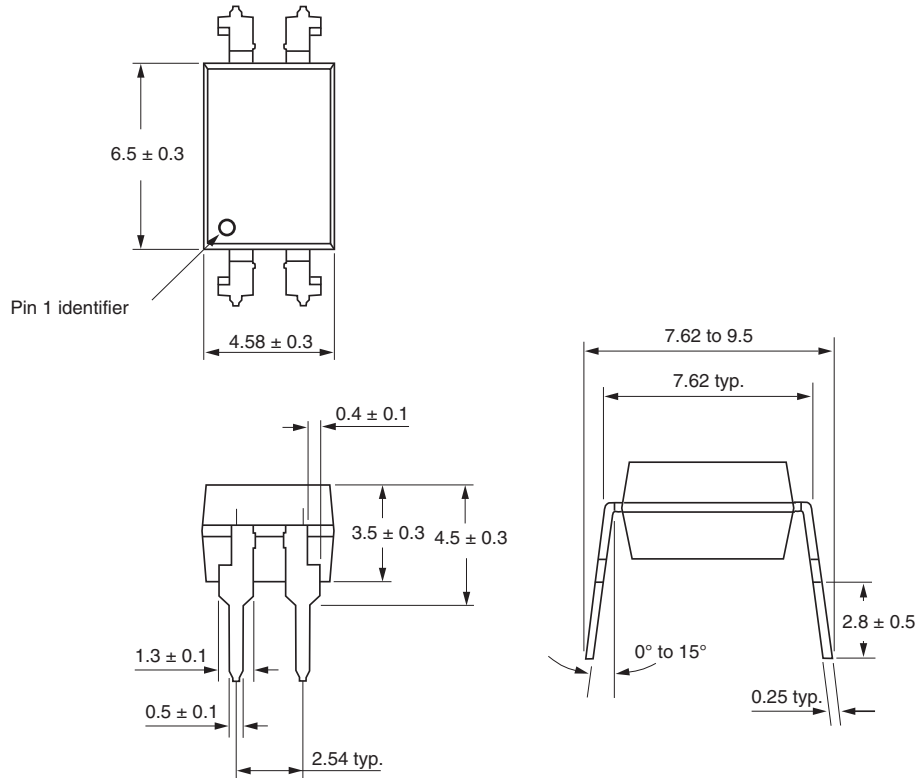

TCET1110G type

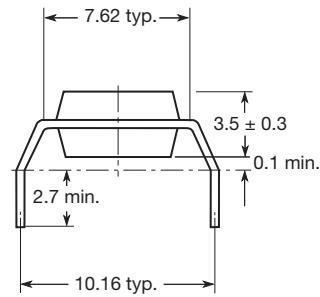

i178027-19

PACKAGE MARKING (example)

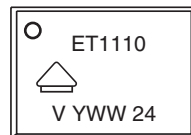



Disclaimer

ALL PRODUCT, PRODUCT SPECIFICATIONS AND DATA ARE SUBJECT TO CHANGE WITHOUT NOTICE TO IMPROVE RELIABILITY, FUNCTION OR DESIGN OR OTHERWISE.

Vishay Intertechnology, Inc., its affiliates, agents, and employees, and all persons acting on its or their behalf (collectively, "Vishay"), disclaim any and all liability for any errors, inaccuracies or incompleteness contained in any datasheet or in any other disclosure relating to any product.

Vishay makes no warranty, representation or guarantee regarding the suitability of the products for any particular purpose or the continuing production of any product. To the maximum extent permitted by applicable law, Vishay disclaims (i) any and all liability arising out of the application or use of any product, (ii) any and all liability, including without limitation special, consequential or incidental damages, and (iii) any and all implied warranties, including warranties of fitness for particular purpose, non-infringement and merchantability.

Statements regarding the suitability of products for certain types of applications are based on Vishay's knowledge of typical requirements that are often placed on Vishay products in generic applications. Such statements are not binding statements about the suitability of products for a particular application. It is the customer's responsibility to validate that a particular product with the properties described in the product specification is suitable for use in a particular application. Parameters provided in datasheets and/or specifications may vary in different applications and performance may vary over time. All operating parameters, including typical parameters, must be validated for each customer application by the customer's technical experts. Product specifications do not expand or otherwise modify Vishay's terms and conditions of purchase, including but not limited to the warranty expressed therein.

Except as expressly indicated in writing, Vishay products are not designed for use in medical, life-saving, or life-sustaining applications or for any other application in which the failure of the Vishay product could result in personal injury or death. Customers using or selling Vishay products not expressly indicated for use in such applications do so at their own risk. Please contact authorized Vishay personnel to obtain written terms and conditions regarding products designed for such applications.

No license, express or implied, by estoppel or otherwise, to any intellectual property rights is granted by this document or by any conduct of Vishay. Product names and markings noted herein may be trademarks of their respective owners.

Material Category Policy

Vishay Intertechnology, Inc. hereby certifies that all its products that are identified as RoHS-Compliant fulfill the definitions and restrictions defined under Directive 2011/65/EU of The European Parliament and of the Council of June 8, 2011 on the restriction of the use of certain hazardous substances in electrical and electronic equipment (EEE) - recast, unless otherwise specified as non-compliant.

Please note that some Vishay documentation may still make reference to RoHS Directive 2002/95/EC. We confirm that all the products identified as being compliant to Directive 2002/95/EC conform to Directive 2011/65/EU.

Vishay Intertechnology, Inc. hereby certifies that all its products that are identified as Halogen-Free follow Halogen-Free requirements as per JEDEC JS709A standards. Please note that some Vishay documentation may still make reference to the IEC 61249-2-21 definition. We confirm that all the products identified as being compliant to IEC 61249-2-21 conform to JEDEC JS709A standards.