

KWP Series Datasheet

Power Wirewound Resistor | Radial | Fiber glass core | ceramic case

ORDERING CODE-Example

New SAP Part Nr.:

KWP	20A	J	F	-	RD-	220R	SP
Serie	* Power rating	Tol.	Pack-Code	TCR	Forming type	R Value	Special
		J = ±5% K = ±10%	F = Bulk with fiberglass element	- Base on spec.	RD- = Radial		SP = 1 Pin Short SL = 1 Pin Long DL = 2 Pin Long

Historical VTM Part Nr.:

KWP338 - 3	5	B	220R
Type	Tol.	Pack-Code	R Value
KWP338 - 5	5	B	220R
Type	Tol.	Pack-Code	R Value
KWP338 - 7	5	B	220R
Type	Tol.	Pack-Code	R Value

APPLICATIONS

- Automotive
- Charger
- Alternative Energy
- Power Supply
- Home Appliances
- Industrial

FEATURES

- PCB pluggable style
- Pulse version available
- RoHS and REACH Compliant

ELECTRICAL SPECIFICATIONS

Type		KWP300	KWP400	KWP500	KWP700	KWP900	KWP10A	KWP15A	KWP20A	
Historical Part Number	1 Pin Short	KWP330 - 3	KWP331 - 3	KWP332 - 3	KWP333 - 3	KWP335 - 3	KWP336 - 3	KWP337 - 3	KWP338 - 3	
	1 Pin Long	KWP330 - 5	KWP331 - 5	KWP332 - 5	KWP333 - 5	KWP335 - 5	KWP336 - 5	KWP337 - 5	KWP338 - 5	
	2 Pin Long	KWP330 - 7	KWP331 - 7	KWP332 - 7	KWP333 - 7	KWP335 - 7	KWP336 - 7	KWP337 - 7	KWP338 - 7	
Nominal Power Rating	* P ₂₅ P ₇₀	[W]	3,0	4,0	5,0	7,0	9,0	10,0	15,0	20,0
Resistance Range	Min. [Ω] Max.		2,5	3,3	4,1	5,7	7,4	8,2	12,3	16,4
			R2	R22	R3	R43	R56	R68	R82	R91
E-Series (preferred)		(Other values upon request)								
Tolerances	±[%]	E24 = 5% ; E12 = 10% (Other upon request)								
Temperature Coefficient	±[10 ⁻⁶ K ⁻¹]	J = 5% ; K = 10%								
Working Temperature Range	[°C]	-80 ... +500 Depends on value								
Thermal Resistance	[KW ⁻¹]	-55 ... +275								
Insulation Resistance IEC60115-1 clause 4.6	[MΩ]	> 10 ⁴								
Max. Working Voltage	[V] _{RMS}	$\sqrt{P_{70} \times R}$								
Dielectric Withstanding Voltage IEC60115-1 clause 4.7 (1[min])	[V] _{RMS}	2000								

DIMENSIONS [mm]

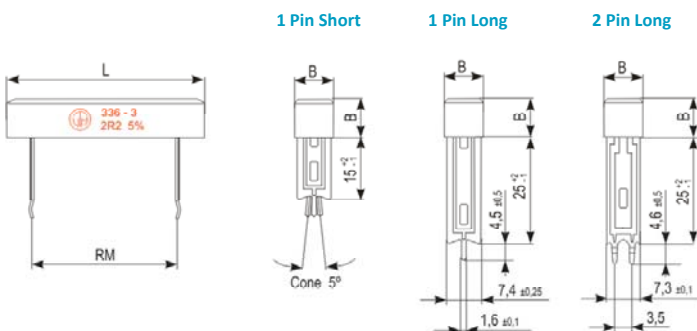

New P/Nr. Type	Historical P/N:	L	B ±0,5	RM
KWP300	KWP330 - 3/5/7	23,0	10,0	10,0
KWP400	KWP331 - 3/5/7	25,0	10,0	12,5
KWP500	KWP332 - 3/5/7	28,0	10,0	15,0
KWP700	KWP333 - 3/5/7	35,5	10,0	22,5
KWP900	KWP335 - 3/5/7	43,0	10,0	30,0
KWP10A	KWP336 - 3/5/7	48,0	10,0	35,0
KWP15A	KWP337 - 3/5/7	50,0	13,0	32,5
KWP20A	KWP338 - 3/5/7	65,0	13,0	47,5

KWP Series Datasheet

PERFORMANCE DATA

Type		KWP300	KWP400	KWP500	KWP700	KWP900	KWP10A	KWP15A	KWP20A
Historical Part Number	1 Pin Short	KWP330-3	KWP331-3	KWP332-3	KWP333-3	KWP335-3	KWP336-3	KWP337-3	KWP338-3
	1 Pin Long	KWP330-5	KWP331-5	KWP332-5	KWP333-5	KWP335-5	KWP336-5	KWP337-5	KWP338-5
	2 Pin Long	KWP330-7	KWP331-7	KWP332-7	KWP333-7	KWP335-7	KWP336-7	KWP337-7	KWP338-7
Derating Linear	[°C]	70...275 (0W)							
Climatic Category		55/200/56							
Failure Rate <small>(Total, θ, max, 60[%] cont. lev.)</small>	[10 ⁻⁹ h ⁻¹]	appr. 100 depends on value							
Endurance <small>IEC60115-1 clause 4.25 (P₇₀ @ 70[°C], 1000[h])</small>	±[%]	3							
Damp Heat, Steady State <small>IEC60115-1 clause 4.24 (40[°C], 93[% r.h.], 56[d])</small>	±[%]	2							
Resistance to Soldering Heat <small>IEC60115-1 clause 4.18 (260^{±5}[°C], 10^{±1}[s])</small>	±[%]	0,5							
Solderability <small>IEC60068-2-20 (245^{±5}[°C] 3^{±0,5}[s])</small>		Solder bath method (> 95% coverage)							
Marking <small>IEC60062</small>		Printed in clear							

PACKAGING

The standard packaging for KWP type is bulk, dimensions below.



New P/Nr. Type	Special	Historical P/N:	Pieces	Pack Code	Forming Type
KWP300	SP ; SL ; DL	KWP330-3 ; 5 ; 7	144	F = Bulk with fiberglass element	RD = Radial
KWP400	SP ; SL ; DL	KWP331-3 ; 5 ; 7	100		
KWP500	SP	KWP332-3	112		
	SL ; DL	KWP332-5 ; 7	128		
KWP700	SP	KWP333-3	120		
	SL ; DL	KWP333-5 ; 7	100		
KWP900	SP	KWP335-3	150		
	SL ; DL	KWP335-5 ; 7	105		
KWP10A	SP	KWP336-3	150		
	SL	KWP336-5	120		
	DL	KWP336-7	100		
KWP15A	SP	KWP337-3	128		
	SL	KWP337-5	50		
	DL	KWP337-7	64		
KWP20A	SP	KWP338-3	100		
	SL ; DL	KWP338-5 ; 7	48		