

Evaluation board for the PWD5T60 compact high-voltage 3-phase power stage with integrated gate driver

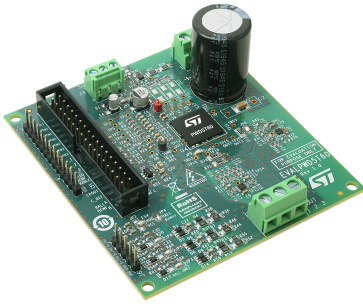

Product status link

[EVLPWD5T60](#)

Features

- High-voltage rail up to 400 V_{DC} (limited by on-board bulk capacitor)
- Output current up to 1.2 A_{peak} (adjustable overcurrent protection threshold)
- Output power up to 120 W
- Driver DC input voltage range: 9 V to 20 V
- Power system-in-package integrating gate drivers and high-voltage power MOSFETs:
 - R_{DS(ON)} = 1.38 Ω
 - BVDSS = 500 V
- Selectable single or three-shunt current sensing topology
- Sensored or sensorless FOC or 6-step algorithm
- Hall effect sensor connector
- Smart shutdown overcurrent protection
- Bus voltage sensing
- Connector for interfacing with MCU
- RoHS compliant

Description

The EVLPWD5T60 evaluation board is a 3-phase power board that allows to evaluate all of the PWD5T60 features.

The board is designed to support a three-shunt or a single-shunt current sensing topology.

A strip connector allows easy interfacing with an MCU control board. The 34-pin ST morpho allows to connect the EVALPWD5T60 board to an STM32 Nucleo board through the X-NUCLEO-IHM09M1 motor control connector expansion board.

The PWD5T60 is a 3-phase high-density power driver integrating gate driver and six N-channel power MOSFETs. It has dedicated input pins for each output and a shutdown pin. The logic inputs are CMOS/TTL compatible down to 3.3 V for easy interfacing with control devices.

1 Safety and operating instructions



1.1 General terms

Warning: *During assembly, testing, and operation, the evaluation board poses several inherent hazards, including bare wires, moving or rotating parts, and hot surfaces.*

Danger: *There is a danger of serious personal injury, property damage, or death due to electrical shock and burn hazards if the kit or components are improperly used or installed incorrectly.*

Attention: *The kit is not electrically isolated from the high-voltage supply DC input. No insulation is ensured between the accessible parts and the high voltage. All measuring equipment must use adequately insulated probes, clamps, and connecting wires. Never touch the evaluation board while it is energized as it is capable of causing an electrical shock hazard.*

Important: *All operations involving transportation, installation and use, and maintenance must be performed by skilled technical personnel able to understand and implement national accident prevention regulations. For the purposes of these basic safety instructions, "skilled technical personnel" are suitably qualified people who are familiar with the installation, use, and maintenance of power electronic systems.*

1.2 Intended use of evaluation board

The evaluation board is designed for demonstration purposes only, and must not be used for electrical installations or machinery. Technical data and information concerning the power supply conditions are detailed in the documentation and should be strictly observed.

1.3 Installing the evaluation board

- The installation and cooling of the evaluation board must be in accordance with the specifications and target application.
- The board must be protected against excessive strain. In particular, components should not be bent nor should isolating distances be altered during transportation or handling.
- No contact must be made with other electronic components and contacts.
- The board contains electrostatically sensitive components that are prone to damage if used incorrectly. Do not mechanically damage or destroy the electrical components (potential health risks).

1.4 Operating the evaluation board

To properly operate the board, follow these safety rules.

1. Work area safety:
 - The work area must be clean and tidy.
 - Do not work alone when boards are energized.
 - Protect against inadvertent access to the area where the board is energized using suitable barriers and signs.
 - A system architecture that supplies power to the evaluation board must be equipped with additional control and protective devices in accordance with the applicable safety requirements (that is, compliance with technical equipment and accident prevention rules).
 - Use a non-conductive and stable work surface.
 - Use adequately insulated clamps and wires to attach measurement probes and instruments.
2. Electrical safety:
 - Remove the power supply from the board and electrical loads before taking any electrical measurements.
 - Proceed with the arrangement of measurement setup, wiring, or configuration paying attention to high-voltage sections.
 - Once the setup is complete, energize the board.

Danger: *Do not touch the board when it is energized or immediately after it has been disconnected from the voltage supply as several parts and power terminals containing potentially energized capacitors need time to discharge.
Do not touch the board after disconnection from the voltage supply as several parts, included PCB, may still be very hot.
The kit is not electrically isolated from DC input.*

3. Personal safety
 - Always wear suitable personal protective equipment such as insulating gloves and safety glasses.
 - Take adequate precautions and install the board in such a way to prevent accidental touch. Use protective shields such as an insulating box with interlocks if necessary.

2 Schematic diagrams

Figure 1. EVLPWD5T60 schematic - driver output stages

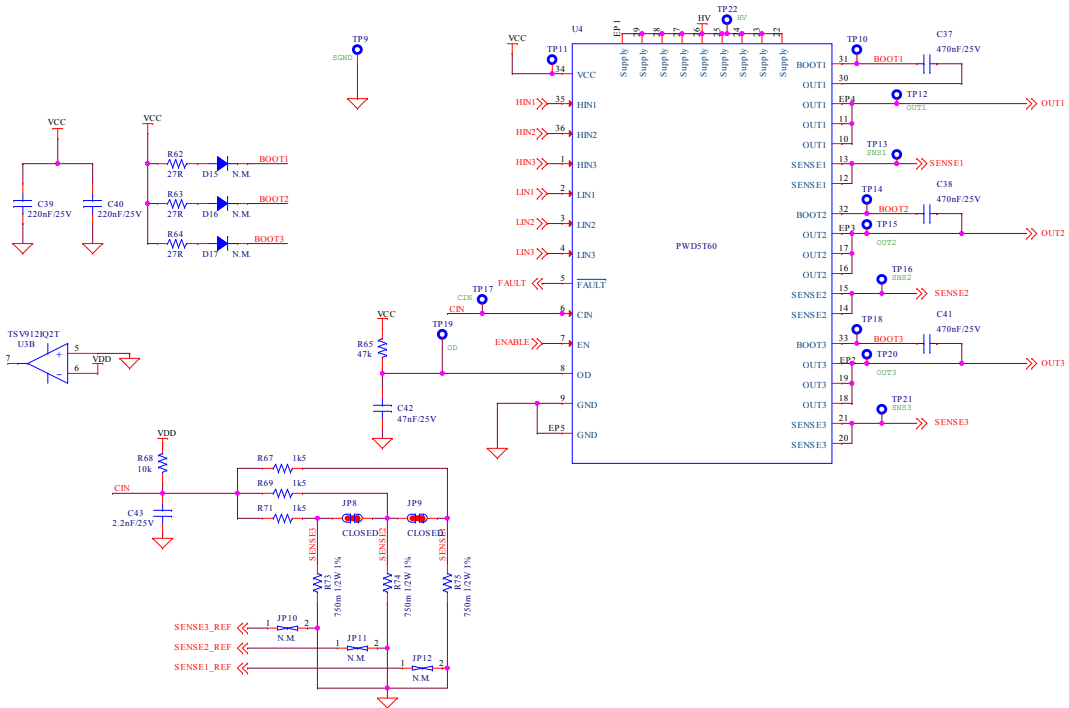
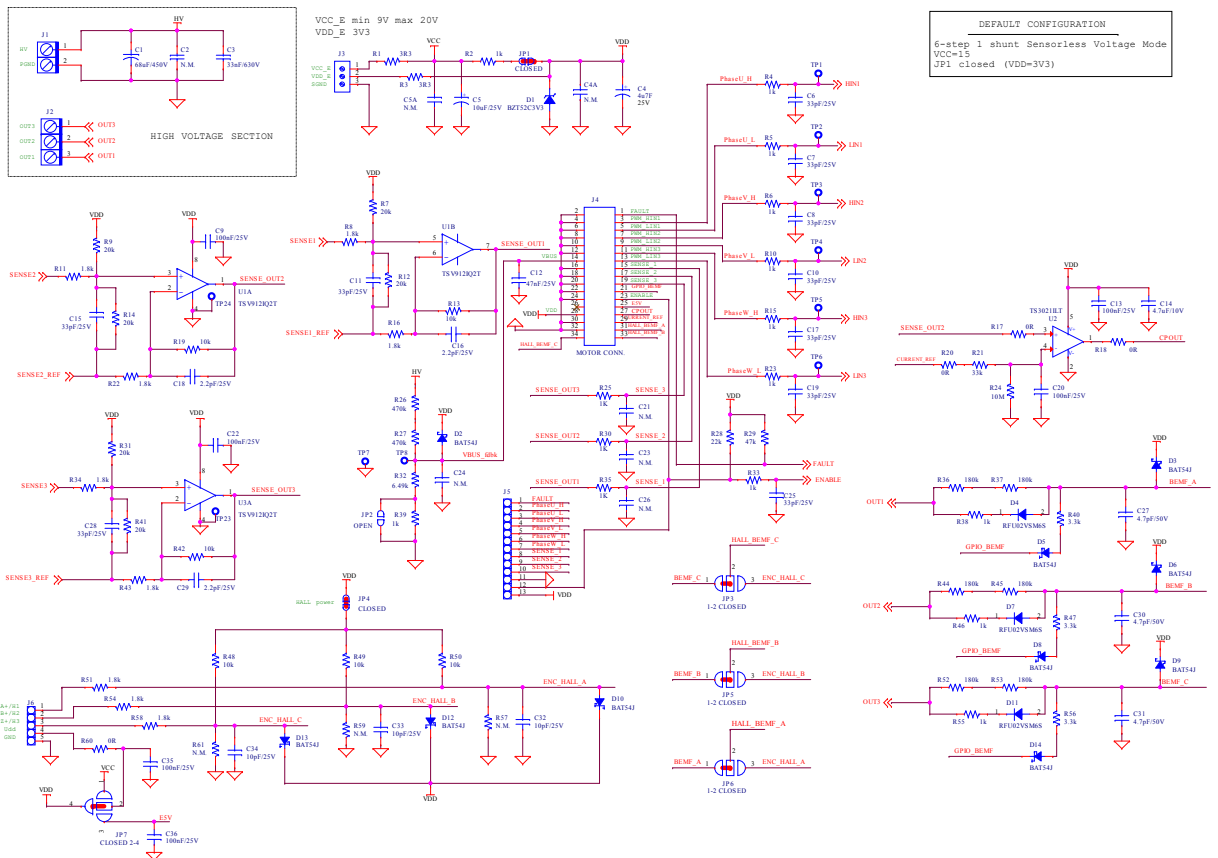

Figure 2. EVLPWD5T60 schematic - feedback network



3 Bill of materials

Table 1. EVLPWD5T60 bill of materials

Part reference	Part description	Part value	Package / manufacturer' code
C1	THT electrolytic capacitor	68 μ F / 450 V	Radial p7.5 d18h25 mm Rubycon 450BXW68MEFC18X25 or equivalent
C2	Film metallized polypropylene	N.M.	4x13 mm, pitch 10 mm Kemet R71MF31004030K or equivalent
C3	SMT multilayer capacitor	33 nF / 630 V	Size 1210
C4	SMD aluminum electrolytic capacitor	4.7 μ F / 25 V	4x5.4 mm Würth Elektronik 865230440001 or equivalent
C4A	SMT ceramic capacitor	N.M.	Size 0805
C5	SMD aluminum electrolytic capacitor	10 μ F / 25 V	5x5.4 mm Panasonic EEE-1EA100SR or equivalent
C5A	SMT ceramic capacitor	N.M.	Size 1206
C6, C7, C8, C10, C11, C15, C17, C19, C25, C28	SMT ceramic capacitor	33 nF / 25 V	Size 0603
C9, C13, C20, C22, C35, C36	SMT ceramic capacitor	100 nF / 25 V	Size 0603
C12, C42	SMT ceramic capacitor	47 nF / 25 V	Size 0603
C14	SMT ceramic capacitor	4.7 μ F / 10 V	Size 0805
C16, C18, C29	SMT ceramic capacitor	2.2 pF / 25 V	Size 0603
C21, C23, C24, C26	SMT ceramic capacitor	N.M.	Size 0603
C27, C30, C31	SMT ceramic capacitor	4.7 pF / 50 V	Size 0603
C32, C33, C34	SMT ceramic capacitor	10 pF / 25 V	Size 0603
C37, C38, C41	SMT ceramic capacitor	4.7 nF / 25 V	Size 0603
C39, C40	SMT ceramic capacitor	220 nF / 25 V	Size 0603
C43	SMT ceramic capacitor	2.2 nF / 25 V	Size 0603
D1	3.3 V Zener diode	BZT52C3V3	SOD-123
D2, D3, D5, D6, D8, D9, D10, D12, D13, D14	40 V, 300 mA small signal Schottky SMT diode	BAT54J	SOD-323 STMicroelectronics BAT54JFILM
D4, D7, D11	600 V, 0.2 A super fast recovery diodes	-	TUMD2SM Rohm semiconductor RFU02VSM6S or equivalent
D15, D16, D17	Turbo 2 ultrafast high-voltage rectifier	N.M.	SMA STMicroelectronics STTH1L06A
JP1, JP4	SMT jumper	Closed	Soldering pad
JP2	SMT jumper	Open	Soldering pad
JP3, JP5, JP6	SMT jumper	Closed 1-2	Soldering pad
JP7	SMT jumper	Closed 2-4	Soldering pad

Part reference	Part description	Part value	Package / manufacturer' code
JP8, JP9	SMT jumper	Closed	Soldering pad 0805
J1	Connector terminal block T.H.	MORSV-508-2P_screw	2 poles, pitch 5.08 mm Phoenix Contact 1715721 or equivalent
J2	Connector terminal block T.H.	MORSV-508-3P_screw	3 poles, pitch 5.08 mm Phoenix Contact 1715857 or equivalent
J3	Connector terminal block T.H. 3 positions 3.5 mm	MORSV-350-3P_screw	3 poles, pitch 3.5 mm Würth Elektronik 691214110003 or equivalent
J4	Header vertical connector	Con-flat-17x2-180m	2x17 poles, pitch 2.54 mm TE Connectivity 3-1761603-1 or equivalent
J5	Strip connector	1x13 pins, 2.54 mm	Amphenol FCI 68000-413HLF or equivalent
J6	Strip connector	1x5 pins, 2.54 mm	Amphenol FCI 68000-405HLF or equivalent
R1, R3	SMT resistor	3.3 Ω	Size 0603
R2	SMT resistor	1 k Ω	Size 1206
R4, R5, R6, R10, R15, R23, R25, R30, R33, R35	SMT resistor	1 k Ω	Size 0603
R7, R9, R12, R14, R31, R41	SMT resistor	20 k Ω	Size 0603
R8, R11, R16, R22, R34, R43, R51, R54, R58	SMT resistor	1.8 k Ω	Size 0603
R13, R19, R42, R48, R49, R50, R68	SMT resistor	10 k Ω	Size 0603
R17, R18, R20, R60	SMT resistor	0 Ω	Size 0603
R21	SMT resistor	33 k Ω	Size 0603
R24	SMT resistor	10 M Ω	Size 0603
R26, R27	SMT resistor	470 k Ω	Size 1206
R28	SMT resistor	22 k Ω	Size 0603
R29, R65	SMT resistor	47 k Ω	Size 0603
R32	SMT resistor	6.49 k Ω	Size 0805
R36, R37, R44, R45, R52, R53	SMT resistor	180 k Ω	Size 1206
R38, R39, R46, R55	SMT resistor	1 k Ω	Size 0805
R40, R47, R56	SMT resistor	3.3 k Ω	Size 0603
R57, R59, R61	SMT resistor	N.M.	Size 0603
R62, R63, R64	SMT resistor	27 Ω	Size 0805
R67, R69, R71	SMT resistor	1.5 k Ω	Size 0603
R73, R74, R75	SMT resistor	750 m Ω / ½ W / 1%	Size 1206 Vishay RCWE1206R750FKEA or equivalent

Part reference	Part description	Part value	Package / manufacturer' code
TP1, TP2, TP3, TP4, TP5, TP6, TP7, TP8, TP10, TP12, TP13, TP14, TP15, TP16, TP17, TP18, TP19, TP20, TP21, TP22, TP23, TP24	Test point for probe	-	Metallized hole, 0.8 mm
TP9	Ring test point, black	-	Diam. 2.54, hole 1 mm Vero Technologies 20-2137 or equivalent
TP11	Ring test point, red	-	Diam. 2.54, hole 1 mm Vero Technologies 20-313137 or equivalent
U1, U3	Rail-to-rail input/output 8 MHz GBP op amp	TSV912IQ2T	DFN8 2x2 STMicroelectronics
U2	Rail-to-rail 1.8 V high-speed comparator	TS3021ILT	SOT23-5 STMicroelectronics
U4	Compact high-voltage 3-phase power stage with integrated gate driver	PWD5T60	VFQFPN 12x12x0.95 mm, 36L STMicroelectronics

4 Layout and component placements

Figure 3. EVLPWD5T60 layout - component placement (top view)

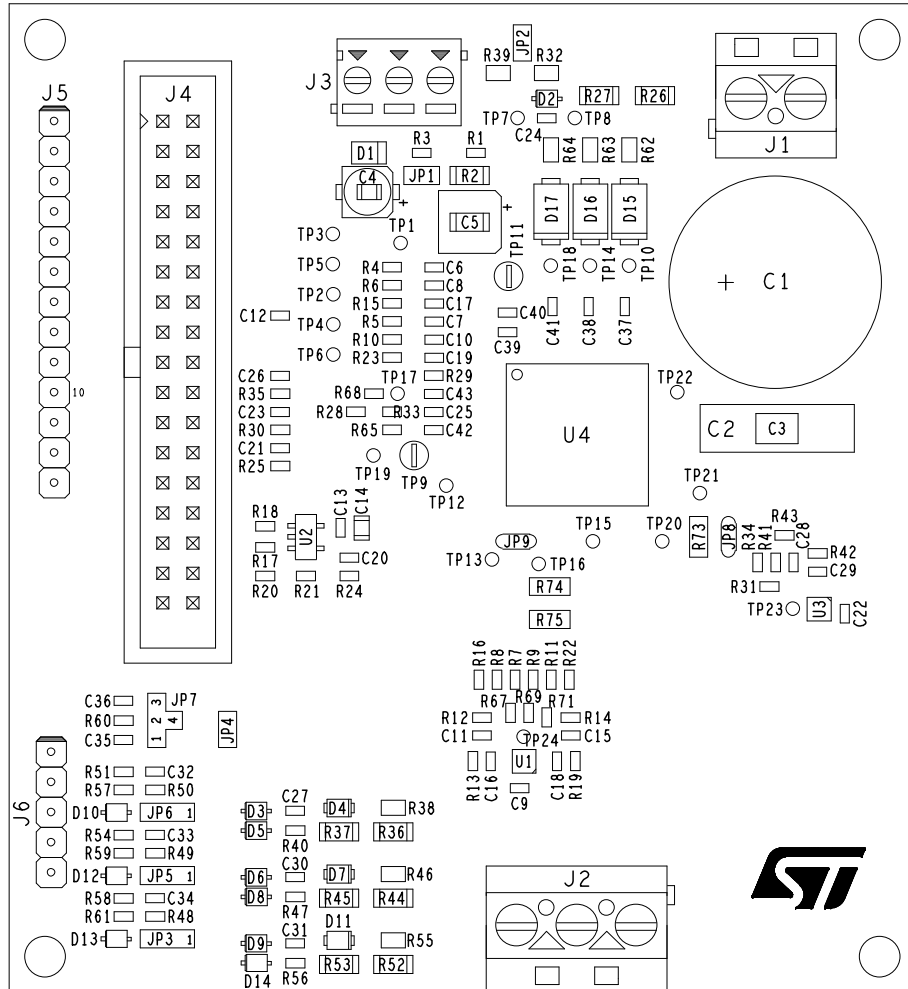

Figure 4. EVLPWD5T60 layout - top layer

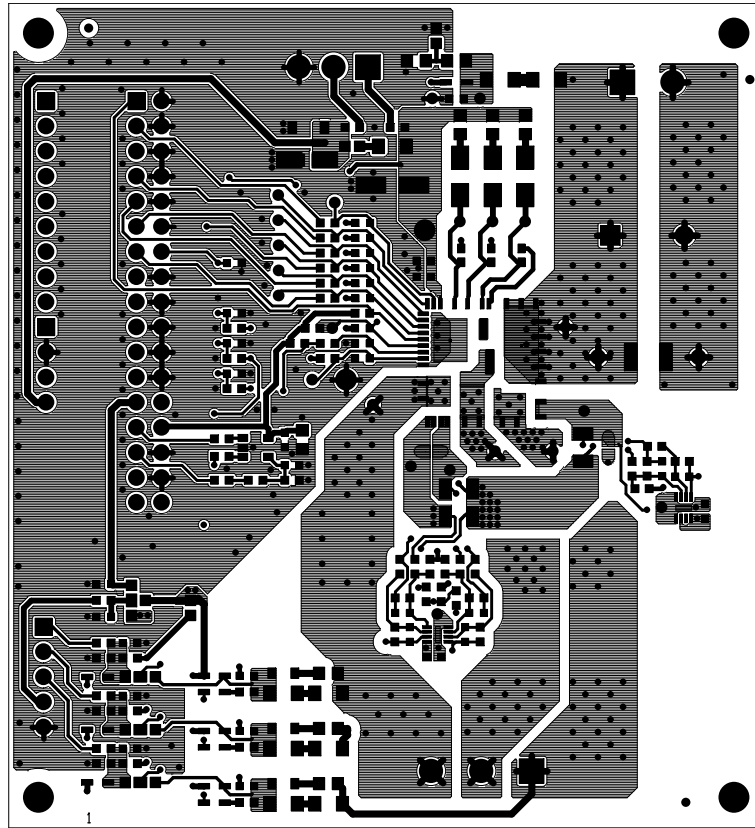

Figure 5. EVLPWD5T60 layout - inner layer 2

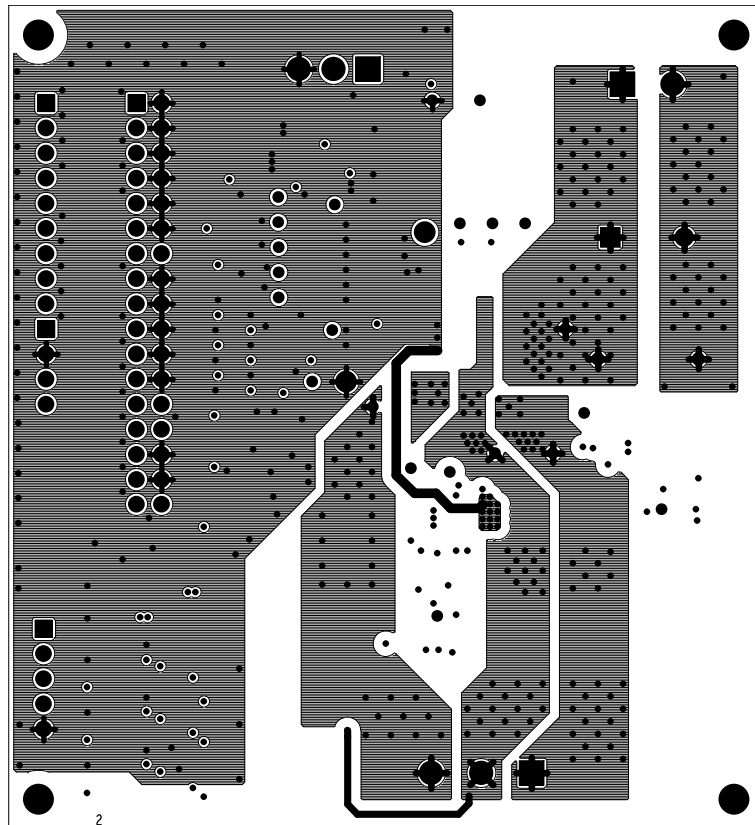

Figure 6. EVLPWD5T60 layout - inner layer 3

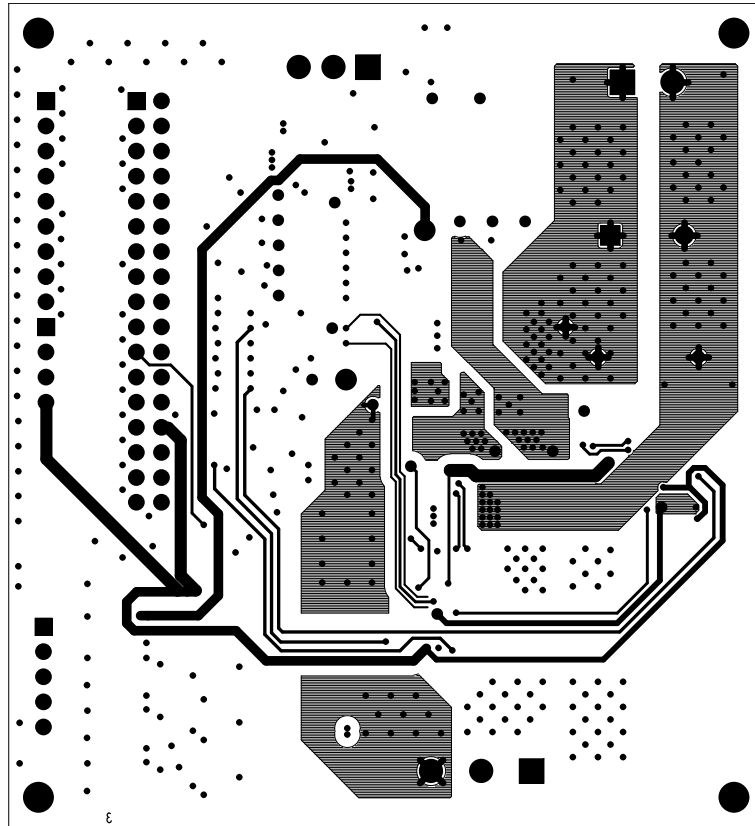
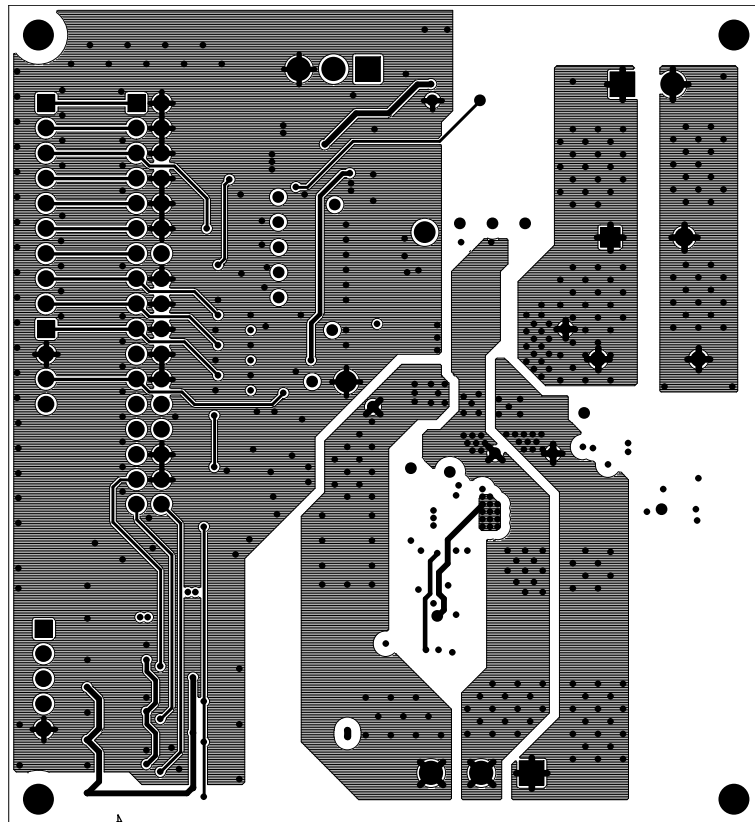

Figure 7. EVLPWD5T60 layout - bottom layer



Revision history

Table 2. Document revision history

Date	Version	Changes
09-May-2024	1	Initial release.

Contents

1	Safety and operating instructions	2
1.1	General terms	2
1.2	Intended use of evaluation board	2
1.3	Installing the evaluation board	2
1.4	Operating the evaluation board	3
2	Schematic diagrams	4
3	Bill of materials	5
4	Layout and component placements	8
	Revision history	11
	List of tables	13
	List of figures	14



List of tables

Table 1.	EVLPWD5T60 bill of materials	5
Table 2.	Document revision history	11

List of figures

Figure 1.	EVLPWD5T60 schematic - driver output stages	4
Figure 2.	EVLPWD5T60 schematic - feedback network.	4
Figure 3.	EVLPWD5T60 layout - component placement (top view)	8
Figure 4.	EVLPWD5T60 layout - top layer	9
Figure 5.	EVLPWD5T60 layout - inner layer 2	9
Figure 6.	EVLPWD5T60 layout - inner layer 3	10
Figure 7.	EVLPWD5T60 layout - bottom layer	10

IMPORTANT NOTICE – READ CAREFULLY

STMicroelectronics NV and its subsidiaries (“ST”) reserve the right to make changes, corrections, enhancements, modifications, and improvements to ST products and/or to this document at any time without notice. Purchasers should obtain the latest relevant information on ST products before placing orders. ST products are sold pursuant to ST’s terms and conditions of sale in place at the time of order acknowledgment.

Purchasers are solely responsible for the choice, selection, and use of ST products and ST assumes no liability for application assistance or the design of purchasers’ products.

No license, express or implied, to any intellectual property right is granted by ST herein.

Resale of ST products with provisions different from the information set forth herein shall void any warranty granted by ST for such product.

ST and the ST logo are trademarks of ST. For additional information about ST trademarks, refer to www.st.com/trademarks. All other product or service names are the property of their respective owners.

Information in this document supersedes and replaces information previously supplied in any prior versions of this document.

© 2024 STMicroelectronics – All rights reserved