

# CSD95410 Synchronous Buck NexFET™ Smart Power Stage

## 1 Features

- 90-A peak continuous current
- Over 95% system efficiency at 30 A
- High-frequency operation (up to 1.75 MHz)
- Diode emulation function
- Temperature compensated bi-directional current sense
- Analog temperature output
- Fault monitoring
- 3.3-V and 5-V PWM signal compatible
- Tri-state PWM input
- Integrated bootstrap switch
- Optimized dead-time for shoot-through protection
- High-density industry common QFN 5-mm × 6-mm footprint
- Ultra-low-inductance package
- System optimized PCB footprint
- Thermally enhanced topside cooling
- RoHS compliant: lead-free terminal plating
- Halogen free

## 2 Applications

- Multiphase synchronous buck converters
  - High-frequency applications
  - High-current, low-duty cycle applications
- Point-of-load DC-DC converters
- Memory and graphic cards
- Desktop and server VR12.x / VR13.x / VR14.x V-core synchronous buck converters

## 3 Description

The CSD95410 NexFET™ power stage is a highly optimized design for use in a high-power, high-density synchronous buck converter. This product integrates the driver IC and power MOSFETs to complete the power stage switching function. This combination produces high-current, high-efficiency, and high-speed switching capability in a small 5-mm × 6-mm outline package. It also integrates the accurate current sensing and temperature sensing functionality to simplify system design and improve accuracy. In addition, the PCB footprint has been optimized to help reduce design time and simplify the completion of the overall system design.

### Device Information

DEVICE	MEDIA	QTY	PACKAGE <sup>(1)</sup>	SHIP
CSD95410	13-Inch Reel	2500	QFN 5.00-mm × 6.00-mm	Tape and Reel
CSD95410T	7-Inch Reel	250		

(1) For all available packages, see the orderable addendum at the end of the data sheet.

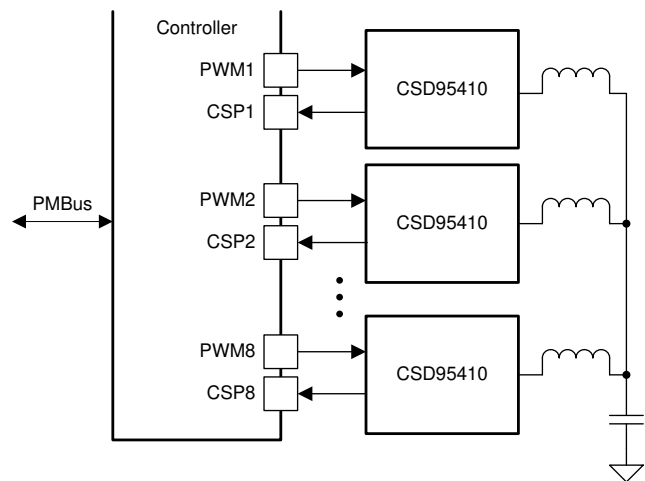

**Simplified Application**



## Table of Contents

<b>1 Features</b> .....	<a href="#">1</a>	5.7 Glossary.....	<a href="#">3</a>
<b>2 Applications</b> .....	<a href="#">1</a>	<b>6 Mechanical, Packaging, and Orderable Information</b> ...	<a href="#">4</a>
<b>3 Description</b> .....	<a href="#">1</a>	6.1 Mechanical Drawing.....	<a href="#">4</a>
<b>4 Revision History</b> .....	<a href="#">2</a>	6.2 Recommended PCB Land Pattern.....	<a href="#">5</a>
<b>5 Device and Documentation Support</b> .....	<a href="#">3</a>	6.3 Recommended Stencil Opening.....	<a href="#">6</a>
5.1 Device Support.....	<a href="#">3</a>	6.4 Alternate Industry Standard Compatible PCB Land Pattern.....	<a href="#">7</a>
5.2 Documentation Support.....	<a href="#">3</a>	6.5 Alternate Industry Standard Compatible Stencil Opening.....	<a href="#">8</a>
5.3 Receiving Notification of Documentation Updates.....	<a href="#">3</a>	6.6 Package Option Addendum.....	<a href="#">9</a>
5.4 Support Resources.....	<a href="#">3</a>		
5.5 Trademarks.....	<a href="#">3</a>		
5.6 Electrostatic Discharge Caution.....	<a href="#">3</a>		

## 4 Revision History

DATE	REVISION	NOTES
September 2020	*	Initial release.

## 5 Device and Documentation Support

### 5.1 Device Support

#### 5.1.1 Third-Party Products Disclaimer

TI'S PUBLICATION OF INFORMATION REGARDING THIRD-PARTY PRODUCTS OR SERVICES DOES NOT CONSTITUTE AN ENDORSEMENT REGARDING THE SUITABILITY OF SUCH PRODUCTS OR SERVICES OR A WARRANTY, REPRESENTATION OR ENDORSEMENT OF SUCH PRODUCTS OR SERVICES, EITHER ALONE OR IN COMBINATION WITH ANY TI PRODUCT OR SERVICE.

### 5.2 Documentation Support

#### 5.3 Receiving Notification of Documentation Updates

To receive notification of documentation updates, navigate to the device product folder on [ti.com](http://ti.com). Click on *Subscribe to updates* to register and receive a weekly digest of any product information that has changed. For change details, review the revision history included in any revised document.

### 5.4 Support Resources

[TI E2E™ support forums](#) are an engineer's go-to source for fast, verified answers and design help — straight from the experts. Search existing answers or ask your own question to get the quick design help you need.

Linked content is provided "AS IS" by the respective contributors. They do not constitute TI specifications and do not necessarily reflect TI's views; see TI's [Terms of Use](#).

### 5.5 Trademarks

NexFET™ and TI E2E™ are trademarks of Texas Instruments.  
All trademarks are the property of their respective owners.

### 5.6 Electrostatic Discharge Caution



This integrated circuit can be damaged by ESD. Texas Instruments recommends that all integrated circuits be handled with appropriate precautions. Failure to observe proper handling and installation procedures can cause damage.

ESD damage can range from subtle performance degradation to complete device failure. Precision integrated circuits may be more susceptible to damage because very small parametric changes could cause the device not to meet its published specifications.

### 5.7 Glossary

[TI Glossary](#) This glossary lists and explains terms, acronyms, and definitions.





### 6.3 Recommended Stencil Opening

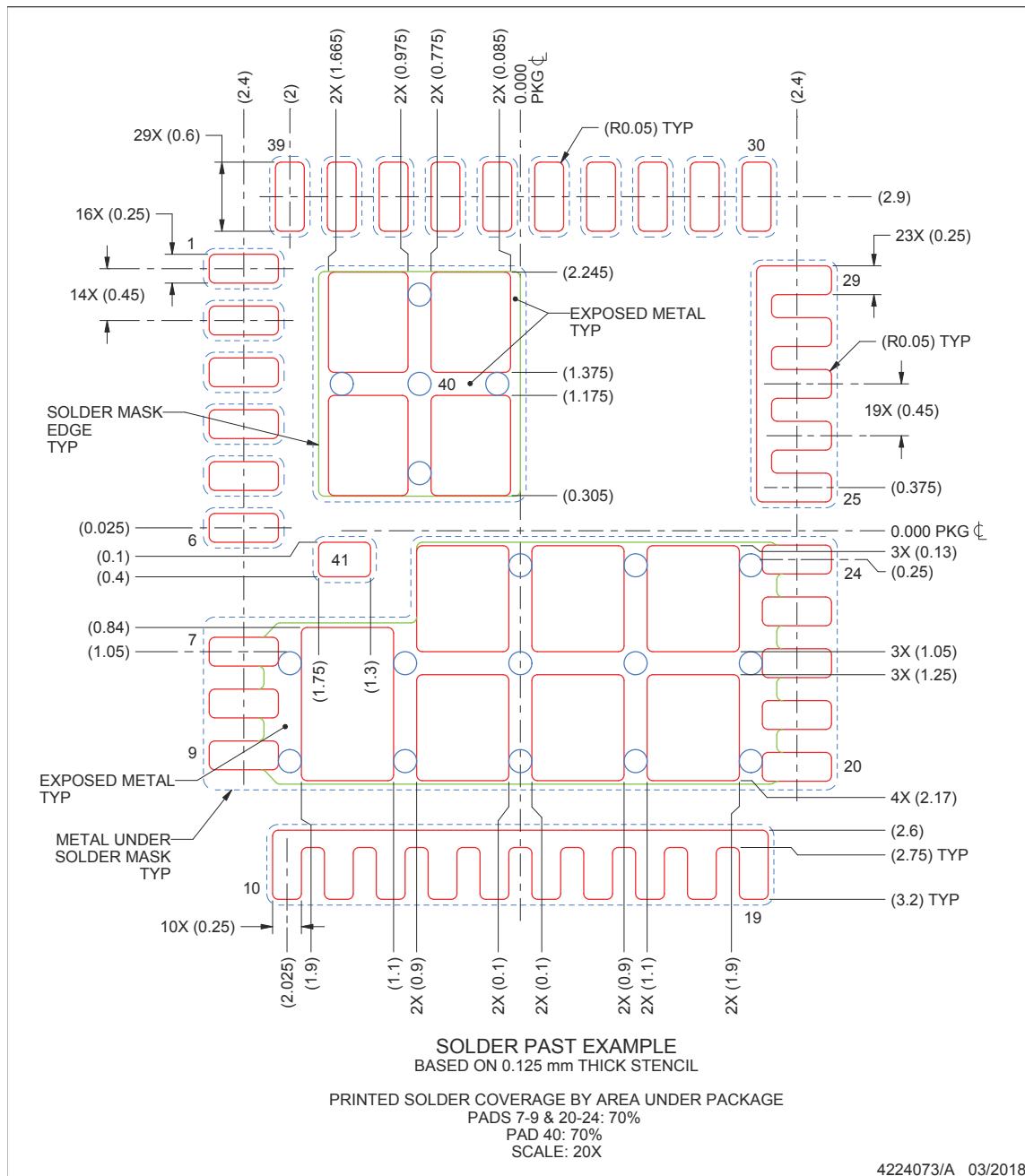

1. All linear dimensions are in millimeters. Any dimensions in parenthesis are for reference only. Dimensioning and tolerancing per ASME Y14.5M.
2. This drawing is subject to change without notice.
3. Laser cutting apertures with trapezoidal walls and rounded corners may offer better paste release. IPC-7525 may have alternate design recommendations.



### 6.5 Alternate Industry Standard Compatible Stencil Opening

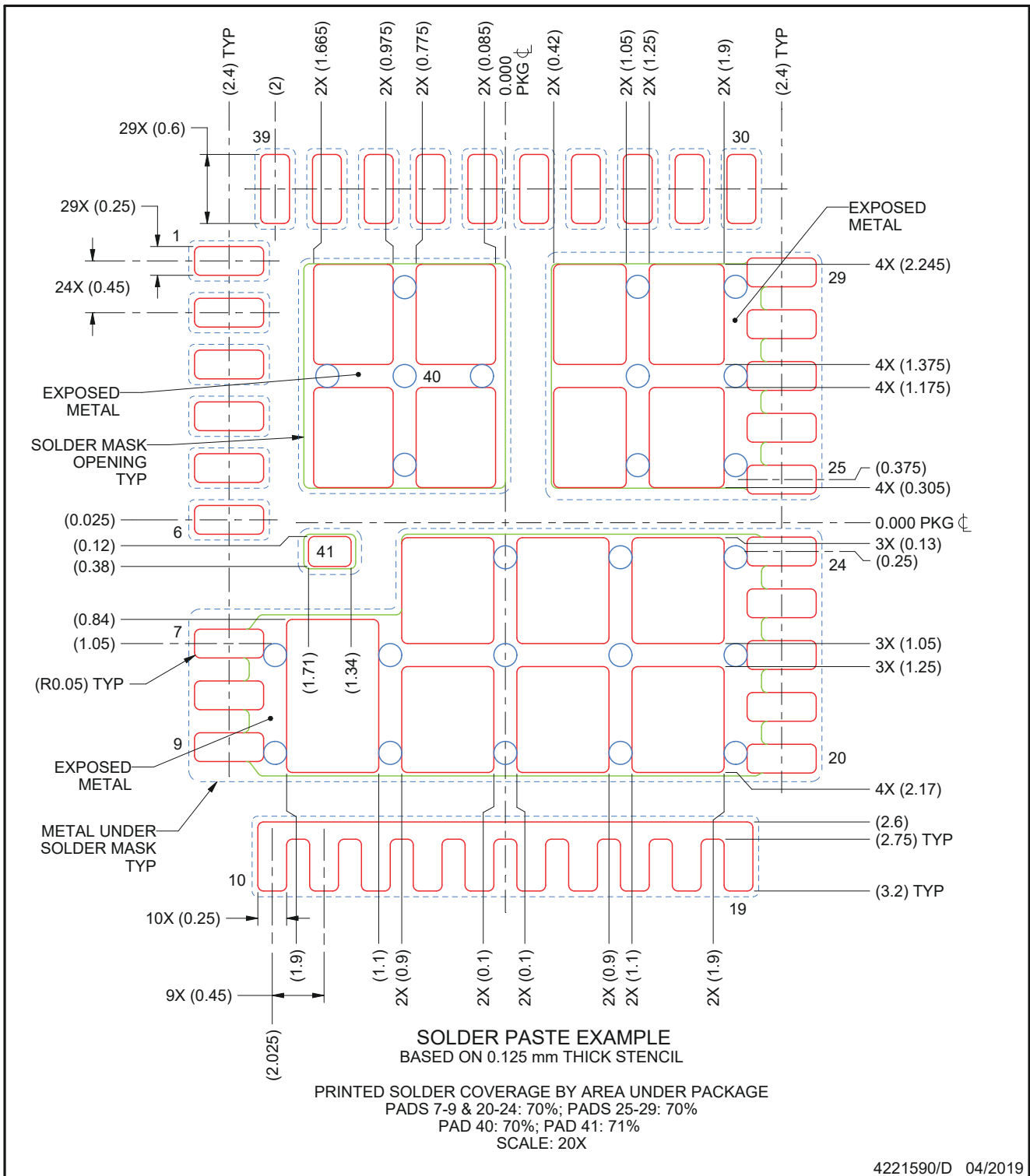

## 6.6 Package Option Addendum

## PACKAGING INFORMATION

Orderable part number	Status (1)	Material type (2)	Package   Pins	Package qty   Carrier	RoHS (3)	Lead finish/ Ball material (4)	MSL rating/ Peak reflow (5)	Op temp (°C)	Part marking (6)
<a href="#">CSD95410RRB</a>	Active	Production	VQFN-CLIP (RRB)   41	2500   LARGE T&R	ROHS Exempt	NIPDAU   SN	Level-2-260C-1 YEAR	-40 to 125	95410RRB
CSD95410RRB.A	Active	Production	VQFN-CLIP (RRB)   41	2500   LARGE T&R	ROHS Exempt	NIPDAU	Level-2-260C-1 YEAR	-40 to 125	95410RRB
CSD95410RRB.B	Active	Production	VQFN-CLIP (RRB)   41	2500   LARGE T&R	ROHS Exempt	NIPDAU	Level-2-260C-1 YEAR	-40 to 125	95410RRB
<a href="#">CSD95410RRBT</a>	Active	Production	VQFN-CLIP (RRB)   41	250   SMALL T&R	ROHS Exempt	NIPDAU   SN	Level-2-260C-1 YEAR	-40 to 125	95410RRB
CSD95410RRBT.A	Active	Production	VQFN-CLIP (RRB)   41	250   SMALL T&R	ROHS Exempt	NIPDAU	Level-2-260C-1 YEAR	-40 to 125	95410RRB
CSD95410RRBT.B	Active	Production	VQFN-CLIP (RRB)   41	250   SMALL T&R	ROHS Exempt	NIPDAU	Level-2-260C-1 YEAR	-40 to 125	95410RRB

(1) **Status:** For more details on status, see our [product life cycle](#).

(2) **Material type:** When designated, preproduction parts are prototypes/experimental devices, and are not yet approved or released for full production. Testing and final process, including without limitation quality assurance, reliability performance testing, and/or process qualification, may not yet be complete, and this item is subject to further changes or possible discontinuation. If available for ordering, purchases will be subject to an additional waiver at checkout, and are intended for early internal evaluation purposes only. These items are sold without warranties of any kind.

(3) **RoHS values:** Yes, No, RoHS Exempt. See the [TI RoHS Statement](#) for additional information and value definition.

(4) **Lead finish/Ball material:** Parts may have multiple material finish options. Finish options are separated by a vertical ruled line. Lead finish/Ball material values may wrap to two lines if the finish value exceeds the maximum column width.

(5) **MSL rating/Peak reflow:** The moisture sensitivity level ratings and peak solder (reflow) temperatures. In the event that a part has multiple moisture sensitivity ratings, only the lowest level per JEDEC standards is shown. Refer to the shipping label for the actual reflow temperature that will be used to mount the part to the printed circuit board.

(6) **Part marking:** There may be an additional marking, which relates to the logo, the lot trace code information, or the environmental category of the part.

Multiple part markings will be inside parentheses. Only one part marking contained in parentheses and separated by a "~" will appear on a part. If a line is indented then it is a continuation of the previous line and the two combined represent the entire part marking for that device.

**Important Information and Disclaimer:** The information provided on this page represents TI's knowledge and belief as of the date that it is provided. TI bases its knowledge and belief on information provided by third parties, and makes no representation or warranty as to the accuracy of such information. Efforts are underway to better integrate information from third parties. TI has taken and continues to take reasonable steps to provide representative and accurate information but may not have conducted destructive testing or chemical analysis on incoming materials and chemicals. TI and TI suppliers consider certain information to be proprietary, and thus CAS numbers and other limited information may not be available for release.

In no event shall TI's liability arising out of such information exceed the total purchase price of the TI part(s) at issue in this document sold by TI to Customer on an annual basis.



**TAPE AND REEL INFORMATION**

**QUADRANT ASSIGNMENTS FOR PIN 1 ORIENTATION IN TAPE**

\*All dimensions are nominal

Device	Package Type	Package Drawing	Pins	SPQ	Reel Diameter (mm)	Reel Width W1 (mm)	A0 (mm)	B0 (mm)	K0 (mm)	P1 (mm)	W (mm)	Pin1 Quadrant
CSD95410RRB	VQFN-CLIP	RRB	41	2500	330.0	12.4	5.3	6.3	1.2	8.0	12.0	Q1
CSD95410RRBT	VQFN-CLIP	RRB	41	250	180.0	12.4	5.3	6.3	1.2	8.0	12.0	Q1

**TAPE AND REEL BOX DIMENSIONS**

\*All dimensions are nominal

Device	Package Type	Package Drawing	Pins	SPQ	Length (mm)	Width (mm)	Height (mm)
CSD95410RRB	VQFN-CLIP	RRB	41	2500	367.0	367.0	38.0
CSD95410RRBT	VQFN-CLIP	RRB	41	250	213.0	191.0	35.0

## IMPORTANT NOTICE AND DISCLAIMER

TI PROVIDES TECHNICAL AND RELIABILITY DATA (INCLUDING DATA SHEETS), DESIGN RESOURCES (INCLUDING REFERENCE DESIGNS), APPLICATION OR OTHER DESIGN ADVICE, WEB TOOLS, SAFETY INFORMATION, AND OTHER RESOURCES "AS IS" AND WITH ALL FAULTS, AND DISCLAIMS ALL WARRANTIES, EXPRESS AND IMPLIED, INCLUDING WITHOUT LIMITATION ANY IMPLIED WARRANTIES OF MERCHANTABILITY, FITNESS FOR A PARTICULAR PURPOSE OR NON-INFRINGEMENT OF THIRD PARTY INTELLECTUAL PROPERTY RIGHTS.

These resources are intended for skilled developers designing with TI products. You are solely responsible for (1) selecting the appropriate TI products for your application, (2) designing, validating and testing your application, and (3) ensuring your application meets applicable standards, and any other safety, security, regulatory or other requirements.

These resources are subject to change without notice. TI grants you permission to use these resources only for development of an application that uses the TI products described in the resource. Other reproduction and display of these resources is prohibited. No license is granted to any other TI intellectual property right or to any third party intellectual property right. TI disclaims responsibility for, and you will fully indemnify TI and its representatives against, any claims, damages, costs, losses, and liabilities arising out of your use of these resources.

TI's products are provided subject to [TI's Terms of Sale](#) or other applicable terms available either on [ti.com](https://www.ti.com) or provided in conjunction with such TI products. TI's provision of these resources does not expand or otherwise alter TI's applicable warranties or warranty disclaimers for TI products.

TI objects to and rejects any additional or different terms you may have proposed.

Mailing Address: Texas Instruments, Post Office Box 655303, Dallas, Texas 75265

Copyright © 2025, Texas Instruments Incorporated