

LM5012 100-V Input, 2.5-A Non-Synchronous Buck DC/DC Converter With Ultra-low I_Q

1 Features

- Designed for reliable and rugged applications
 - Wide input voltage range of 6 V to 100 V
 - 40°C to +125°C junction temperature range
 - Fixed 3-ms internal soft-start timer
 - Peak current-limit protection
 - Input UVLO and thermal shutdown protection
- Functional Safety-Capable**
 - [Documentation available to aid functional safety system design](#)
- Optimized for ultra-low EMI requirements
 - Meets [CISPR 25 Class 5](#) standard
- Suited for scalable industrial power supplies
 - Pin-to-pin compatible with the LM5163 and LM5164 (100 V, 0.5 A or 1 A), and LM5013-Q1 (100 V, 3.5A)
 - 50-ns low minimum on and off times
 - Diode emulation for high light-load efficiency
 - 10- μ A no-load sleep current
 - 3.1- μ A shutdown quiescent current
- Integration reduces solution size and cost
 - COT mode control architecture
 - Integrated 100-V 0.25- Ω power MOSFET
 - 1.2-V internal voltage reference
 - No loop compensation components
 - Internal VCC bias regulator and boot diode
- Create a custom regulator design using [WEBENCH® Power Designer](#)

2 Applications

- [Hybrid, electric, and powertrain systems](#)
- [Inverter and motor control](#)
- [Industrial transport](#)

3 Description

The LM5012 non-synchronous buck converter is designed to regulate over a wide input voltage range, minimizing the need for external surge suppression components. A minimum controllable on time of 50 ns facilitates large step-down conversion ratios, enabling the direct step-down from a 48-V nominal input to low-voltage rails for reduced system complexity and solution cost. The LM5012 operates during input voltage dips as low as 6 V, at nearly 100% duty cycle if needed, making it an excellent choice for high-performance industrial applications.

With integrated high-side power MOSFET, the LM5012 delivers up to 2.5 A of output current. A constant on-time (COT) control architecture provides nearly constant switching frequency with excellent load and line transient response. Additional features of the LM5012 include ultra-low I_Q and an innovative peak overcurrent protection, integrated VCC bias supply and bootstrap diode, precision enable and input UVLO, and thermal shutdown protection with automatic recovery. An open-drain PGOOD indicator provides sequencing, fault reporting, and output voltage monitoring.

The LM5012 is available in a 8-pin SO PowerPAD™ integrated circuit package. The device 1.27-mm pin pitch provides adequate spacing for high-voltage applications.

Package Information

Part Number	Package ⁽¹⁾	Body Size (NOM)
LM5012	DDA (SO PowerPAD, 8)	4.89 mm × 3.90 mm

- (1) For all available packages, see the orderable addendum at the end of the data sheet.

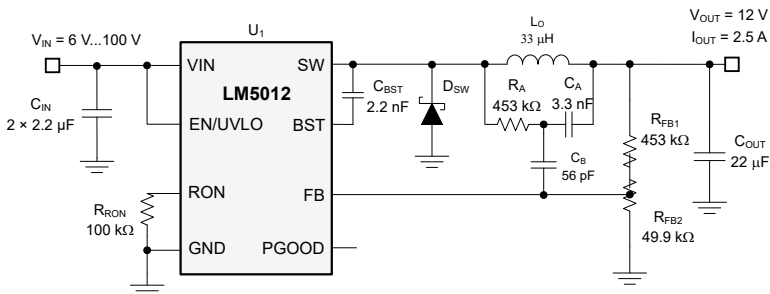

Typical Application

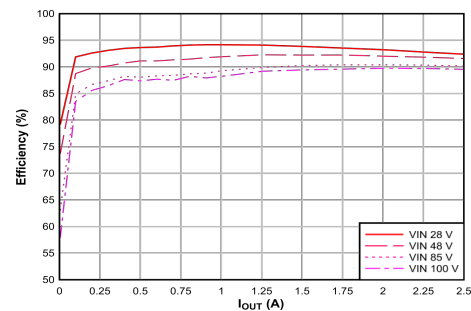

Typical Application Efficiency, $V_{OUT} = 12\text{ V}$



Table of Contents

1 Features	1	8.4 Device Functional Modes.....	16
2 Applications	1	9 Application and Implementation	17
3 Description	1	9.1 Application Information.....	17
4 Revision History	2	9.2 Typical Application.....	17
5 Device Comparison Table	3	9.3 Power Supply Recommendations.....	24
6 Pin Configuration and Functions	4	9.4 Layout.....	24
7 Specifications	5	10 Device and Documentation Support	29
7.1 Absolute Maximum Ratings.....	5	10.1 Device Support.....	29
7.2 ESD Ratings_Catalog.....	5	10.2 Documentation Support.....	29
7.3 Recommended Operating Conditions.....	6	10.3 Receiving Notification of Documentation Updates..	30
7.4 Thermal Information.....	6	10.4 Support Resources.....	30
7.5 Electrical Characteristics.....	6	10.5 Trademarks.....	30
7.6 Typical Characteristics.....	8	10.6 Electrostatic Discharge Caution.....	30
8 Detailed Description	10	10.7 Glossary.....	30
8.1 Overview.....	10	11 Mechanical, Packaging, and Orderable	
8.2 Functional Block Diagram.....	11	Information	30
8.3 Feature Description.....	11		

4 Revision History

DATE	REVISION	NOTES
October 2022	*	Initial release

5 Device Comparison Table

Device	Description	Orderable Part Number	Package	V _{IN}	I _{OUT}
LM5163-Q1	Automotive 100-V input, 0.5-A synchronous buck converter	LM5163QDDARQ1	SO PowerPAD (8) integrated circuit package	100 V	0.5 A
LM5164-Q1	Automotive 100-V input, 1-A synchronous buck converter	LM5164QDDARQ1	SO PowerPAD (8) integrated circuit package	100 V	1 A
LM5012-Q1	Automotive 100-V, 2.5-A non-synchronous buck converter	LM5012QDDARQ1	SO PowerPAD (8) integrated circuit package	100 V	2.5 A
LM5012	100-V input, 2.5-A non-synchronous buck converter	LM5012DDAR	SO PowerPAD (8) integrated circuit package	100 V	2.5 A
LM5013-Q1	Automotive, 100-V, 3.5-A non-synchronous buck converter	LM5013QDDARQ1	SO PowerPAD (8) integrated circuit package	100 V	3.5 A
LM5013	100-V, 3.5-A non-synchronous buck converter	LM5013DDAR	SO PowerPAD (8) integrated circuit package	100 V	3.5 A

6 Pin Configuration and Functions

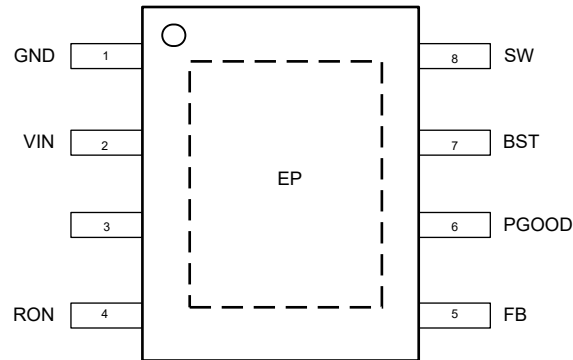

Figure 6-1. 8-Pin SO PowerPAD™ DDA integrated circuit Package (Top View)

Table 6-1. Pin Functions

Pin		Type ⁽¹⁾	Description
Name	NO.		
GND	1	G	Ground connection for internal circuits
VIN	2	P/I	Regulator supply input pin to the high-side power MOSFET and internal bias regulator. Connect directly to the input supply of the buck converter with short, low impedance paths.
EN/UVLO	3	I	Precision enable and undervoltage lockout (UVLO) programming pin. If the EN/UVLO voltage is below 1.1 V, the converter is in shutdown mode with all functions disabled. If the UVLO voltage is greater than 1.1 V and below 1.5 V, the converter is in standby mode with the internal VCC regulator operational and no switching. If the EN/UVLO voltage is above 1.5 V, the start-up sequence begins.
RON	4	I	On-time programming pin. A resistor between this pin and GND sets the buck switch on time.
FB	5	I	Feedback input of voltage regulation comparator
PGOOD	6	O	Power-good indicator. This pin is an open-drain output pin. Connect to a source voltage through an external pullup resistor between 10 kΩ to 100 kΩ.
BST	7	P/I	Bootstrap gate-drive supply. Connect a high-quality 2.2-nF, 50-V X7R ceramic capacitor between BST and SW to bias the internal high-side gate driver.
SW	8	P	Switching node that is internally connected to the source of the high-side NMOS buck switch. Connect to the switching node of the power inductor.
EP	—	—	Exposed pad of the package. No internal electrical connection. Connect the EP to the GND pin and connect to a large copper plane to reduce thermal resistance.

(1) G = Ground, I = Input, O = Output, P = Power

7 Specifications

7.1 Absolute Maximum Ratings

Over operating junction temperature range (unless otherwise noted) ⁽¹⁾

		MIN	MAX	UNIT
Pin voltage	VIN to GND	-0.3	100	V
Pin voltage	SW to GND	-1.5	100	V
Pin voltage	SW to GND, <20-ns transient	-3		V
Pin voltage	BST to GND	-3	105.5	V
Pin voltage	BST to SW	-0.3	5.5	V
Pin voltage	EN/UVLO to GND	-0.3	100	V
Pin voltage	FB, RON to GND	-0.3	5.5	V
Pin voltage	PGOOD to GND	-0.3	14	V
Bootstrap capacitor	External BST to SW capacitor	1.5	2.5	nF
T _J	Operating junction temperature	-40	150	°C
T _{stg}	Storage temperature	-65	150	°C

- (1) Operation outside the *Absolute Maximum Ratings* may cause permanent damage to the device. Absolute Maximum Ratings do not imply functional operation of the device at these or any other conditions beyond those listed under Recommended Operation Condition. If used outside the Recommended Operating Conditions but within the Absolute Maximum Ratings, the device may not be fully functional, and this may affect device reliability, functionality, performance, and shorten the device lifetime.

7.2 ESD Ratings_Catalog

		VALUE	UNIT
V _(ESD)	Electrostatic discharge	Human-body model (HBM), per ANSI/ESDA/JEDEC JS-001 ⁽¹⁾	V
		Charged-device model (CDM), per ANSI/ESDA/JEDEC JS-002 ⁽²⁾	

- (1) JEDEC document JEP155 states that 500-V HBM allows safe manufacturing with a standard ESD control process.
 (2) JEDEC document JEP157 states that 250-V CDM allows safe manufacturing with a standard ESD control process.

7.3 Recommended Operating Conditions

Over the operating junction temperature range (unless otherwise noted).

			MIN	NOM	MAX	UNIT
V _{IN}	Input voltage range		6		100	V
	Pin voltage	SW to GND	-0.3		100	V
	Pin voltage	BST to GND	-0.3		105.5	V
	Pin voltage	BST to SW	-0.3		5.5	V
	Pin voltage	FB, RON to GND	-0.3		5.5	V
	Pin voltage	EN/UVLO to GND	-0.3		100	V
	PGOOD to GND		-0.3		14	V
	F _{SW}				1000	kHz
t _{ON}	Programmable on-time		50		1000	ns
C _{BST}	External BST to SW capacitance		1.5	2.2	2.5	nF
T _J	Operating junction temperature		-40		150	°C

7.4 Thermal Information

THERMAL METRIC ⁽¹⁾		DDA (SOIC)	UNIT
		8 PINS	
R _{θJA}	Junction-to-ambient thermal resistance (LM5013-Q1 EVM)	29.0	°C/W
R _{θJA}	Junction-to-ambient thermal resistance	34.8	°C/W
R _{θJC(top)}	Junction-to-case (top) thermal resistance	22.8	°C/W
R _{θJB}	Junction-to-board thermal resistance	9.5	°C/W
R _{θJC(bot)}	Junction-to-case (bottom) thermal resistance	1.3	°C/W
Ψ _{JB}	Junction-to-board characterization parameter	9.4	°C/W
Ψ _{JT}	Junction-to-top characterization parameter	0.3	°C/W

(1) For more information about traditional and new thermal metrics, see the [Semiconductor and IC Package Thermal Metrics application report](#).

7.5 Electrical Characteristics

T_J = -40°C to +150°C, V_{IN} = 24 V. Typical values are at T_J = 25°C and V_{EN/UVLO} = 2 V (unless otherwise noted).

PARAMETER		TEST CONDITIONS	MIN	TYP	MAX	UNIT
SUPPLY CURRENT						
I _{Q-SHUTDOWN}	V _{IN} shutdown current	V _{EN/UVLO} = 0V		3.1	9.9	μA
I _{Q-SLEEP}	V _{IN} sleep current	V _{EN} = 2.5 V, V _{FB} = 1.5 V, V _{BST} - V _{SW} = 5 V, non-switching		10	20	μA
I _{Q-STANDBY}	V _{IN} standby current	V _{EN} = 1.2 V		25	40	μA
I _{Q-ACTIVE}	V _{IN} Active current	V _{EN} = 2.5 V		450		μA
EN/UVLO						
V _{SD-RISING}	Shutdown threshold				1.1	V
V _{SD-FALLING}	Shutdown threshold		0.45			V
V _{EN-RISING}	EN threshold rising		1.43	1.5	1.6	V
V _{EN-FALLING}	EN threshold falling		1.35	1.4	1.47	V
FEEDBACK VOLTAGE						
V _{REF}	FB regulation voltage		1.181	1.2	1.218	V
TIMING						
t _{ON1}	On-time1	V _{VIN} = 12 V, R _{RON} = 75 kΩ		2550		ns
t _{ON2}	On-time2	V _{VIN} = 12 V, R _{RON} = 25 kΩ		830		ns
t _{ON3}	On-time3	V _{VIN} = 48 V, R _{RON} = 75 kΩ		625		ns
t _{ON4}	On-time4	V _{VIN} = 48 V, R _{RON} = 25 kΩ		245		ns

7.5 Electrical Characteristics (continued)

$T_J = -40^{\circ}\text{C}$ to $+150^{\circ}\text{C}$, $V_{IN} = 24\text{ V}$. Typical values are at $T_J = 25^{\circ}\text{C}$ and $V_{EN/UVLO} = 2\text{ V}$ (unless otherwise noted).

PARAMETER		TEST CONDITIONS	MIN	TYP	MAX	UNIT
t_{ON5}	On-time5	$V_{VIN} = 100\text{ V}$, $R_{RON} = 75\text{ k}\Omega$		330		ns
t_{ON6}	On-time6	$V_{VIN} = 100\text{ V}$, $R_{RON} = 25\text{ k}\Omega$		128		ns
PGOOD						
V_{PG-UTH}	FB upper threshold for PGOOD low to high	V_{FB} rising	1.1	1.14	1.2	V
V_{PG-LTH}	FB lower threshold for PGOOD high to low	V_{FB} falling	1.05	1.08	1.12	V
V_{PG-HYS}	PGOOD upper and lower threshold hysteresis	V_{FB} falling		60		mV
R_{PG}	PGOOD pulldown resistance	$V_{FB} = 1\text{ V}$		8		Ω
BOOTSTRAP						
V_{BST-UV}	Gate drive UVLO	V_{BST} falling		2.4	3.4	V
POWER SWITCH						
$R_{DSON-HS}$	High-side MOSFET R_{DSON}	$I_{SW} = -100\text{ mA}$		0.25		Ω
SOFT START						
t_{SS}	Internal soft-start		1.75	3.5	4.75	ms
CURRENT LIMIT						
I_{PEAK}	Peak current limit threshold		2.8	3.2	3.6	A
THERMAL SHUTDOWN						
T_{J-SD}	Thermal shutdown threshold ⁽¹⁾	Temperature rising		175		$^{\circ}\text{C}$
T_{J-HYS}	Thermal shutdown hysteresis ⁽¹⁾			10		$^{\circ}\text{C}$

(1) Specified by design. Not product tested.

7.6 Typical Characteristics

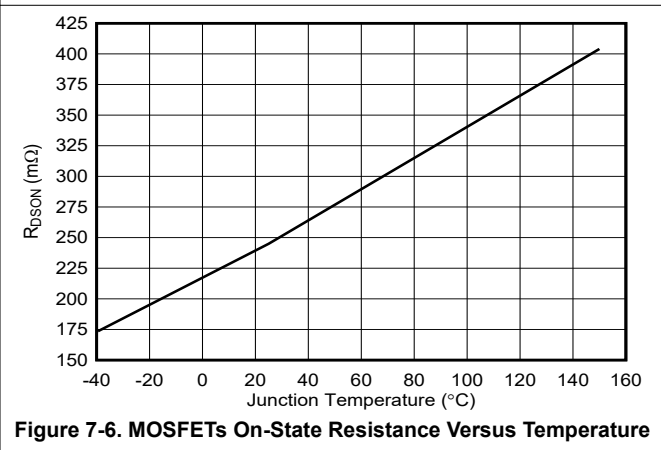
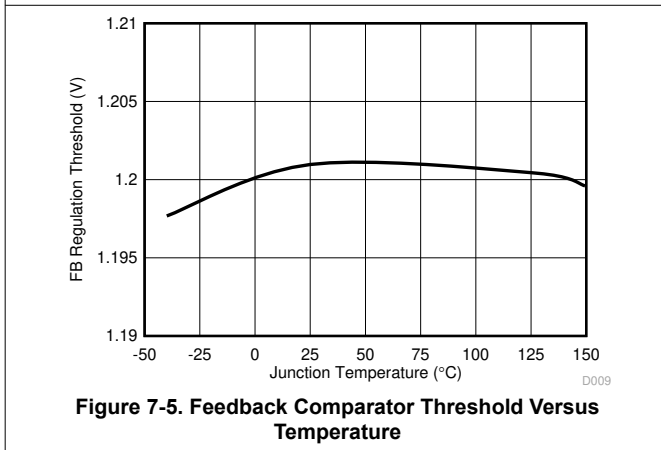
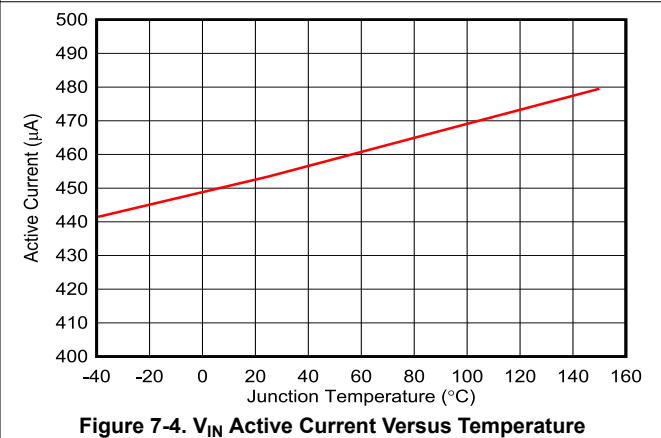
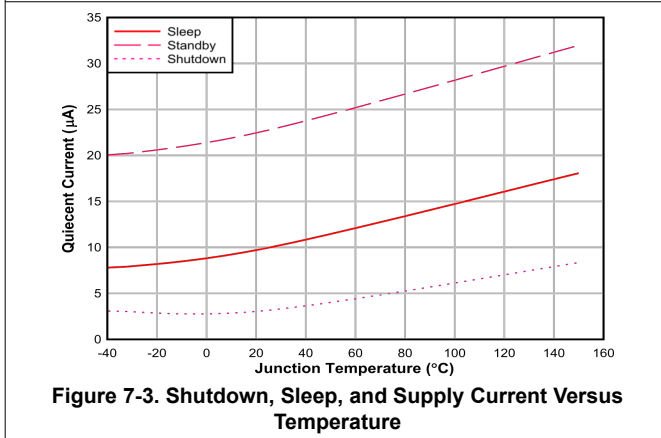
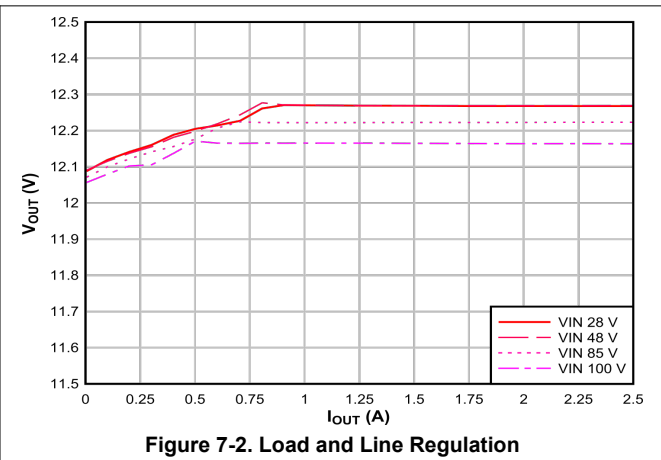
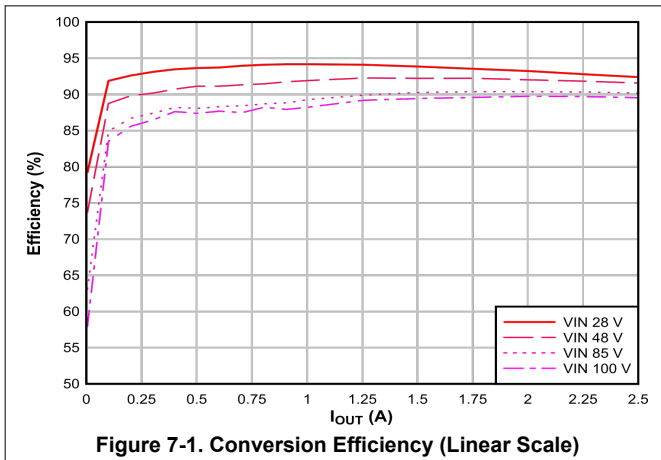

7.6 Typical Characteristics (continued)

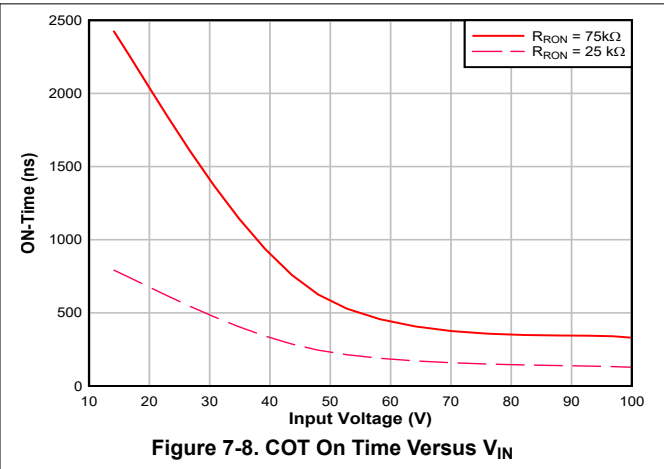
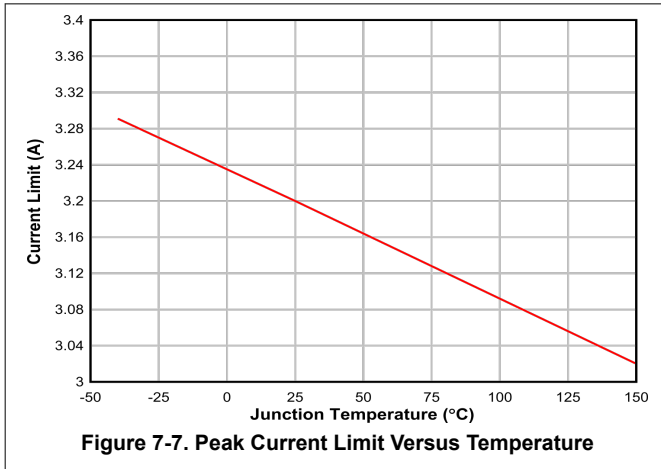

8 Detailed Description

8.1 Overview

The LM5012 is an easy-to-use, ultra-low I_Q constant on-time (COT) non-synchronous step-down buck regulator. With an integrated high-side power MOSFET, the LM5012 is a low-cost, highly efficient buck converter that operates from a wide input voltage of 6 V to 100 V, delivering up to 2.5-ADC load current. The LM5012 is available in an 8-pin SO PowerPAD intergrated circuit package with 1.27-mm pin pitch for adequate spacing in high-voltage applications. This constant on-time (COT) converter is ideal for low-noise, high-current, and fast load transient requirements, operating with adaptive on-time switching pulse. Over the input voltage range, input voltage feedforward is used to achieve a quasi-fixed switching frequency. A controllable on time as low as 50 ns permits high step-down ratios and a minimum forced off time of 50 ns provides extremely high duty cycles, allowing V_{IN} to drop close to V_{OUT} before frequency foldback occurs. At light loads, the device transitions into an ultra-low I_Q mode to maintain high efficiency and prevent draining battery cells connected to the input when the system is in standby. The LM5012 implements a smart peak current limit detection circuit to ensure robust protection during output short circuit conditions. Control loop compensation is not required for this regulator, reducing design time and external component count.

The LM5012 incorporates additional features for comprehensive system requirements:

- Power-rail sequencing and fault reporting
- Internally-fixed soft start
- Open-drain power good
- Monotonic start-up into prebiased loads
- Precision enable for programmable line undervoltage lockout (UVLO)
- Smart cycle-by-cycle current limit for optimal inductor sizing
- Thermal shutdown with automatic recovery

These features enable a flexible and easy-to-use platform for a wide range of applications. The LM5012 supports a wide range of end-equipment systems requiring a regulated output from a high input supply where the transient voltage deviates from the DC level. The following are examples of such end equipment systems:

- High cell-count battery-pack systems
- 24-V industrial systems
- 48-V telecommunication and PoE voltage ranges

The pin arrangement is designed for a simple layout requiring only a few external components.

8.2 Functional Block Diagram

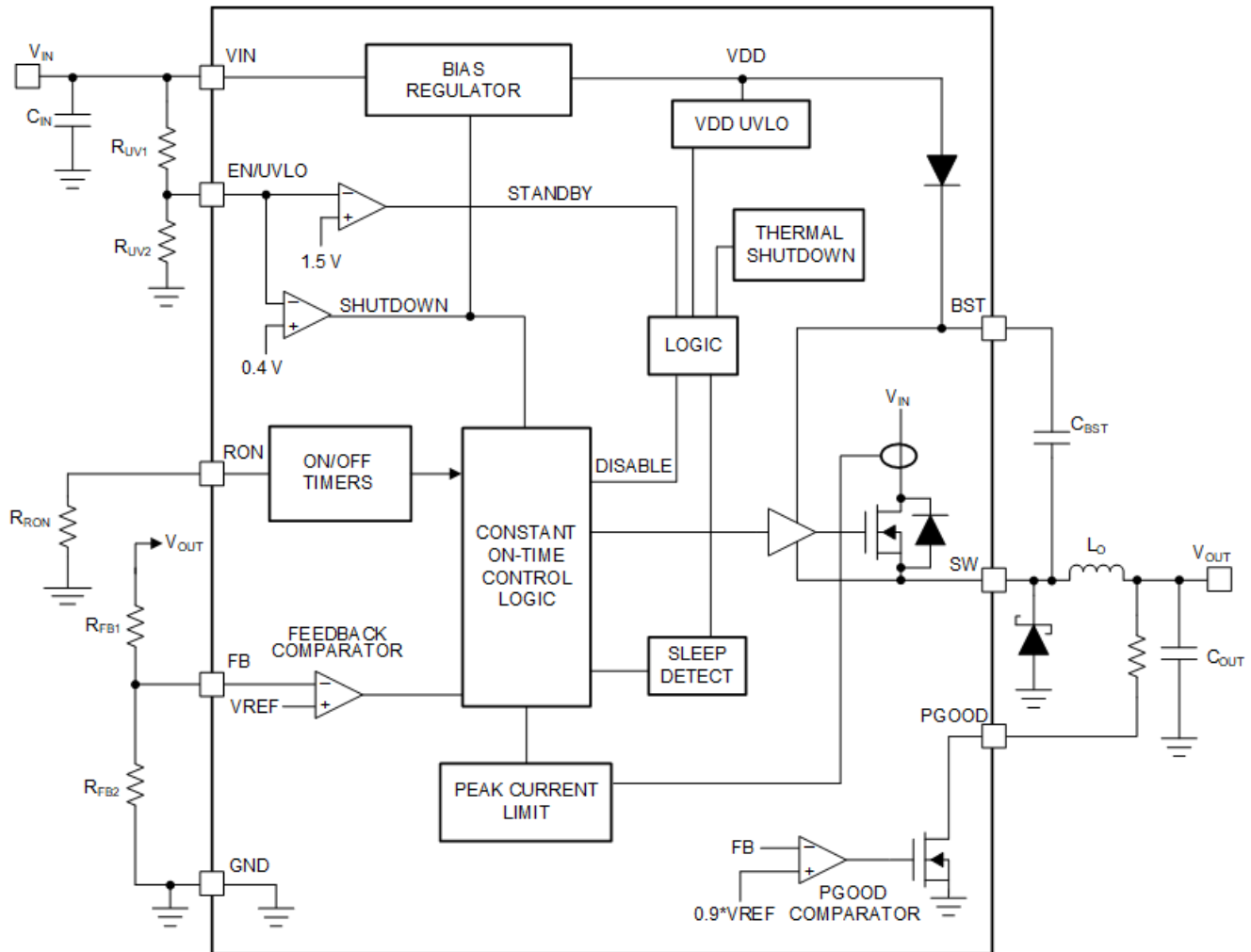

8.3 Feature Description

8.3.1 Control Architecture

The LM5012 step-down switching converter employs a constant on-time (COT) control scheme. The COT control scheme sets a fixed on time, t_{ON} , of the high-side FET using a timing resistor (R_{ON}). t_{ON} is adjusted as V_{IN} changes and is inversely proportional to the input voltage to maintain a fixed frequency when in continuous conduction mode (CCM). After t_{ON} expires, the high-side FET remains off until the feedback pin is equal or below the 1.2-V reference voltage. To maintain stability, the feedback comparator requires a minimal ripple voltage that is in-phase with the inductor current during the off time. Furthermore, this change in feedback voltage during the off time must be large enough to dominate any noise present at the feedback node. The minimum recommended feedback ripple voltage is 20 mV. See [Table 8-1](#) for different types of ripple injection schemes that ensure stability over the full input voltage range.

During a rapid start-up or a positive load step, the regulator operates with minimum off times until regulation is achieved. This feature enables extremely fast load transient response with minimum output voltage undershoot. When regulating the output in steady-state operation, the off time automatically adjusts itself to produce the SW-pin duty cycle required for output voltage regulation to maintain a fixed switching frequency. In CCM, the switching frequency, F_{SW} , is programmed by the R_{RON} resistor. Use [Equation 1](#) to calculate the switching frequency.

$$F_{SW} \text{ (kHz)} = \frac{V_{OUT} \text{ (V)} \cdot 2500}{R_{RON} \text{ (k}\Omega\text{)}} \quad (1)$$

Table 8-1. Ripple Generation Methods

Type 1 Lowest Cost	Type 2 Reduced Ripple	Type 3 Minimum Ripple
		
$R_{ESR} \geq \frac{20\text{mV} \cdot V_{OUT}}{V_{FB1} \cdot \Delta I_{L(\text{nom})}}$ $R_{ESR} \geq \frac{V_{OUT}}{2 \cdot V_{IN} \cdot F_{SW} \cdot C_{OUT}}$	$R_{ESR} \geq \frac{20\text{mV}}{\Delta I_{L(\text{nom})}}$ $R_{ESR} \geq \frac{V_{OUT}}{2 \cdot V_{IN} \cdot F_{SW} \cdot C_{OUT}}$ $C_{FF} \geq \frac{1}{2\pi \cdot F_{SW} \cdot (R_{FB1} \parallel R_{FB2})}$	$C_A \geq \frac{10}{F_{SW} \cdot (R_{FB1} \parallel R_{FB2})}$ $R_A C_A \leq \frac{(V_{IN-\text{nom}} - V_{OUT}) \cdot t_{ON} (@V_{IN-\text{nom}})}{20\text{mV}}$ $C_B \geq \frac{t_{\text{TR-setting}}}{3 \cdot R_{FB1}}$

Table 8-1 presents three different methods for generating appropriate voltage ripple at the feedback node. Type-1 ripple generation method uses a single resistor, R_{ESR} , in series with the output capacitor. The generated voltage ripple has two components: capacitive ripple caused by the inductor ripple current charging and discharging the output capacitor and resistive ripple caused by the inductor ripple current flowing into the output capacitor and through series resistance, R_{ESR} . The capacitive ripple component is out-of-phase with the inductor current and does not decrease monotonically during the off time. The resistive ripple component is in-phase with the inductor current and decreases monotonically during the off time. The resistive ripple must exceed the capacitive ripple at V_{OUT} for stable operation. If this condition is not satisfied, unstable switching behavior is observed in COT converters with multiple on-time bursts in close succession followed by a long off time. The lowest cost bill of materials (BOM) define the value of the series resistance R_{ESR} to ensure sufficient in-phase ripple at the feedback node.

Type-2 ripple generation uses a C_{FF} capacitor in addition to the series resistor. As the output voltage ripple is directly AC-coupled by C_{FF} to the feedback node, the R_{ESR} and ultimately the output voltage ripple, are reduced by a factor of V_{OUT} / V_{FB1} .

Type-3 ripple generation uses an RC network consisting of R_A and C_A , and the switch node voltage to generate a triangular ramp that is in-phase with the inductor current. This triangular wave is the AC-coupled into the feedback node with capacitor C_B . Because this circuit does not use output voltage ripple, it is suited for applications where low output voltage ripple is critical. The [Selecting an Ideal Ripple Generation Network for Your COT Buck Converter](#) application report provides additional details on this topic.

Note

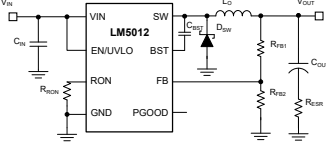
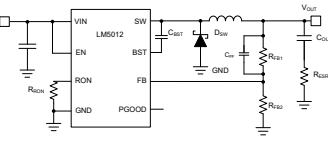
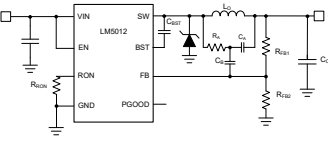
For all methods specified, 12 mV is the minimum FB ripple voltage. 20 mV is calculated as a conservative figure. For wide- V_{IN} ranges, calculating for 20 mV can be insufficient to achieve 12-mV FB ripple at minimum input voltage. Careful evaluation should be done to ensure the minimum ripple requirement is fulfilled, or the design can be faced with large output ripple, irregular switching at the application minimum output voltage.

8.3.2 Internal VCC Regulator and Bootstrap Capacitor

The LM5012 contains an internal linear regulator that is powered from V_{IN} with a nominal output of 5 V, eliminating the need for an external capacitor to stabilize the linear regulator. The internal VCC regulator supplies current to internal circuit blocks including the asynchronous FET driver and logic circuits. The input pin (V_{IN}) can be connected directly to line voltages up to 100 V. As the power MOSFET has a low total gate charge, use a low bootstrap capacitor value to reduce the stress on the internal regulator. Select a high-quality ceramic bootstrap capacitor with an effective value of 2.2 nF, 50 V X7R as specified in the [Absolute Maximum Ratings](#).

VCC does not have current limit protection, so selecting a higher value capacitance can stress the internal VCC regulator and can damage the device. A lower capacitance than required is not sufficient to drive the internal gate of the power MOSFET. An internal diode connects from the VCC regulator to the BST pin to replenish the charge in the high-side gate drive bootstrap capacitor when the SW voltage is low.

8.3.3 Regulation Comparator

The feedback voltage at FB is compared to an internal 1.2-V reference. The LM5012 voltage regulation loop regulates the output voltage by maintaining the FB voltage equal to the internal reference voltage, V_{REF} . A resistor divider programs the ratio from output voltage V_{OUT} to FB.

For a target V_{OUT} setpoint, use [Equation 2](#) to calculate R_{FB2} based on the selected R_{FB1} .

$$R_{FB2} = \frac{1.2V}{V_{OUT} - 1.2V} \cdot R_{FB1} \quad (2)$$

TI recommends selecting R_{FB1} in the range of 100 k Ω to 1 M Ω for most applications. A larger R_{FB1} consumes less DC current, which is mandatory if light-load efficiency is critical. R_{FB1} larger than 1 M Ω is not recommended as the feedback path becomes more susceptible to noise. Ensure to route the feedback trace away from the noisy area of the PCB, minimize the feedback node size, and keep the feedback resistors close to the FB pin.

8.3.4 Internal Soft Start

The LM5012 employs an internal soft-start control ramp that allows the output voltage to gradually reach a steady-state operating point, thereby reducing start-up stresses and current surges. The soft-start feature produces a controlled, monotonic output voltage start-up. The soft-start time is internally set to 3 ms.

8.3.5 On-Time Generator

The on time of the LM5012 high-side FET is determined by the R_{RON} resistor and is inversely proportional to the input voltage, V_{IN} . The inverse relationship with V_{IN} results in a nearly constant frequency as V_{IN} is varied. Use [Equation 3](#) to calculate the on time.

$$t_{ON} (\mu s) = \frac{R_{RON} (k\Omega)}{V_{IN} (V) \cdot 2.5} \quad (3)$$

Use [Equation 4](#) to determine the R_{RON} resistor to set a specific switching frequency in CCM.

$$R_{RON} (k\Omega) = \frac{V_{OUT} (V) \cdot 2500}{F_{SW} (kHz)} \quad (4)$$

Select R_{RON} for a minimum on time (at maximum V_{IN}) greater than 50 ns for proper operation. In addition to this minimum on time, the maximum frequency for this device is limited to 1 MHz.

8.3.6 Current Limit

The LM5012 manages overcurrent conditions with cycle-by-cycle current limiting of the peak inductor current. The current sensed in the high-side MOSFET is compared every switching cycle to the current limit threshold (3.2 A). There is a 100-ns leading-edge blanking time following the high-side MOSFET turn-on transition to eliminate false tripping off the current limit comparator. To protect the converter from potential current runaway conditions, the LM5012 includes a t_{OFF} timer that is proportional to V_{IN} and V_{OUT} that is enabled if a 3.2-A peak current limit is detected. As shown in [Figure 8-1](#), if the peak current in the high-side MOSFET exceeds 3.2 A (typical), the present cycle is immediately terminated regardless of the programmed on time (t_{ON}), the high-side MOSFET is turned off and the t_{OFF} timer is activated. This action allows the peak inductor current to fall from 3.2-A peak to an acceptable value to ensure no excessive current in the power stage. This method folds back the switching frequency to prevent overheating and limits the average output current to less than 3.2 A to ensure proper short-circuit and heavy-load protection of the LM5012. This innovative current limit scheme

enables ultra-low duty-cycle operation, permitting large step-down voltage conversions while ensuring robust protection of the converter.

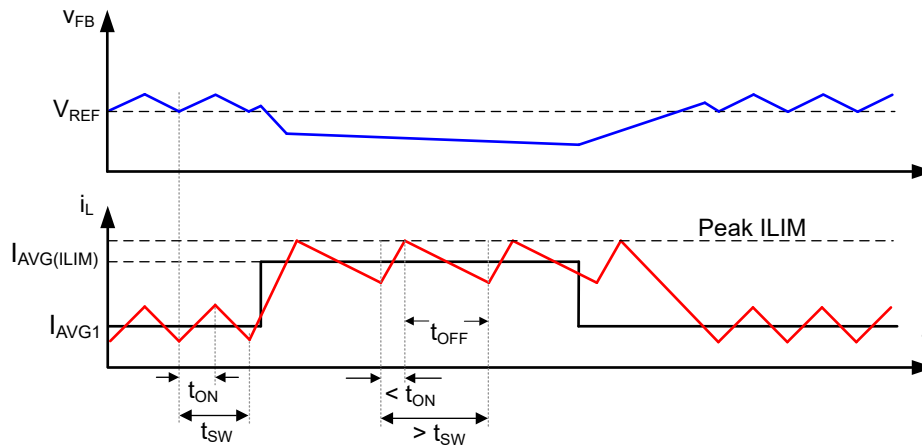

Figure 8-1. Current Limit Timing Diagram

8.3.7 N-Channel Buck Switch and Driver

The LM5012 integrates an N-channel buck switch and associated floating high-side gate driver. The gate-driver circuit works in conjunction with an external bootstrap capacitor and an internal high-voltage bootstrap diode. A high-quality 2.2-nF, 50-V X7R ceramic capacitor connected between the BST and SW pins provides the voltage to the high-side driver during the buck switch on time. During the off time, the SW pin is pulled down to approximately 0 V, and the bootstrap capacitor charges from the internal VCC through the internal bootstrap diode. The minimum off timer, set to 50 ns (typical), ensures a minimum time each cycle to recharge the bootstrap capacitor. When the on time is less than 300 ns, the minimum off timer is forced to 250 ns to ensure that the BST capacitor is charged in a single cycle. This is vital during wake-up from sleep mode when the BST capacitor is most likely discharged.

8.3.8 Schottky Diode Selection

A Schottky diode is required for all LM5012 applications to re-circulate the energy in the output inductor when the high-side MOSFET is off. The reverse breakdown rating of the diode should be greater than the maximum V_{IN} plus a 25% safety margin, as specified in the [Schottky Diode](#) application section. The current rating of the diode must exceed the maximum DC output current and support the peak current limit for the best reliability. In this case, the diode carries the maximum load current.

8.3.9 Enable and Undervoltage Lockout (EN/UVLO)

The LM5012 contains a dual-level EN/UVLO circuit. When the EN/UVLO voltage is below 1.1 V (typical), the converter is in a low-current shutdown mode and the input quiescent current (I_Q) is dropped down to 3 μ A. When the voltage is greater than 1.1 V but less than 1.5 V (typical), the converter is in standby mode. In standby mode, the internal bias regulator is active while the control circuit is disabled. When the voltage exceeds the rising threshold of 1.5 V (typical), normal operation begins. Install a resistor divider from V_{IN} to GND to set the minimum operating voltage of the regulator. Use [Equation 5](#) and [Equation 6](#) to calculate the input UVLO turn-on and turn-off voltages, respectively.

$$V_{IN(on)} = 1.5 \text{ V} \cdot \left(1 + \frac{R_{UV1}}{R_{UV2}} \right) \quad (5)$$

$$V_{IN(off)} = 1.4 \text{ V} \cdot \left(1 + \frac{R_{UV1}}{R_{UV2}} \right) \quad (6)$$

TI recommends selecting R_{UV1} in the range of 1 M Ω for most applications. A larger R_{UV1} consumes less DC current, which is mandatory if light-load efficiency is critical. If input UVLO is not required, the power-supply designer can either drive EN/UVLO as an enable input driven by a logic signal or connect it directly to VIN. If EN/UVLO is directly connected to VIN, the regulator begins switching as soon as the internal bias rails are active.

8.3.10 Power Good (PGOOD)

The LM5012 provides a PGOOD flag pin to indicate when the output voltage is within the regulation level. Use the PGOOD signal for start-up sequencing of downstream converters or for fault protection and output monitoring. PGOOD is an open-drain output that requires a pullup resistor to a DC supply not greater than 14 V. The typical range of pullup resistance is 10 k Ω to 100 k Ω . If necessary, use a resistor divider to decrease the voltage from a higher voltage pullup rail. When the FB voltage exceeds 95% of the internal reference, V_{REF} , the internal PGOOD switch turns off and PGOOD can be pulled high by the external pullup. If the FB voltage falls below 90% of V_{REF} , an internal 25- Ω PGOOD switch turns on and PGOOD is pulled low to indicate that the output voltage is out of regulation. The rising edge of PGOOD has a built-in deglitch delay of 5 μ s.

8.3.11 Thermal Protection

The LM5012 includes an internal junction temperature monitor to protect the device in the event of a higher than normal junction temperature. If the junction temperature exceeds 175°C (typical), thermal shutdown occurs to prevent further power dissipation and temperature rise. The LM5012 initiates a restart sequence when the junction temperature falls to 165°C, based on a typical thermal shutdown hysteresis of 10°C. This protection is a non-latching protection, so the device cycles into and out of thermal shutdown if the fault persists.

8.4 Device Functional Modes

8.4.1 Shutdown Mode

EN/UVLO provides ON and OFF control for the LM5012. When $V_{EN/UVLO}$ is below approximately 1.1 V, the device is in shutdown mode. Both the internal linear regulator and the switching regulator are off. The quiescent current in shutdown mode drops to 3 μA at $V_{IN} = 24\text{ V}$. The LM5012 also employs internal bias rail undervoltage protection. If the internal bias supply voltage is below the UV threshold, the regulator remains off.

8.4.2 Standby Mode

The LM5012 enters standby mode during light or no-load on the output. The LM5012 enters standby mode to prevent draining the input power supply. All internal controller circuits are turned off to reduce the current consumption. The quiescent current in standby mode is 25 μA (typical).

8.4.3 Active Mode

The LM5012 is in active mode when $V_{EN/UVLO}$ is above the precision enable threshold and the internal bias rail is above its UV threshold. In COT active mode, the LM5012 is in one of three modes depending on the load current:

- CCM with fixed switching frequency when load current is above half of the peak-to-peak inductor current ripple
- Pulse skipping and diode emulation mode (DEM) when the load current is less than half of the peak-to-peak inductor current ripple in CCM operation
- Current limit CCM with peak current limit protection when an overcurrent condition is applied at the output

8.4.4 Sleep Mode

The LM5012 converter enters DEM during light-load conditions when the inductor current decays to zero. In DEM state, the load current is lower than half of the peak-to-peak inductor current ripple and the switching frequency decreases when the load is further decreased as the device operates in a pulse skipping mode. A switching pulse is set when V_{FB} drops below 1.2 V.

As the frequency of operation decreases and V_{FB} remains above 1.2 V (V_{REF}) with the output capacitor sourcing the load current for greater than 15 μs , the converter enters an ultra-low I_Q sleep mode to prevent draining the input power supply. The input quiescent current (I_Q) required by the LM5012 decreases to 14 μA in sleep mode, improving the light-load efficiency of the regulator. In this mode, all internal controller circuits are turned off to ensure very low current consumption by the device. Such low I_Q renders the LM5012 as the best option to extend operating lifetime for off-battery applications. The FB comparator and internal bias rail are active to detect when the FB voltage drops below the internal reference, V_{REF} , and the converter transitions out of sleep mode into active mode. There is a 9- μs wake-up delay from sleep to active states.

9 Application and Implementation

Note

Information in the following applications sections is not part of the TI component specification, and TI does not warrant its accuracy or completeness. TI's customers are responsible for determining suitability of components for their purposes, as well as validating and testing their design implementation to confirm system functionality.

9.1 Application Information

The LM5012 requires only a few external components to step down from a wide range of supply voltages to a fixed output voltage. Several features are integrated to meet system design requirements, including the following:

- Precision enable
- Input voltage UVLO
- Internal soft start
- Programmable switching frequency
- A PGOOD indicator

To expedite the process of designing with LM5012, a LM5012 design calculator is available on the product folder "tool" section. This calculator is complemented by an evaluation module for order, PSPICE models, as well as TI's [WEBENCH® Power Designer](#).

9.2 Typical Application

Figure 9-1 shows the schematic for 48-V to 12-V conversion.

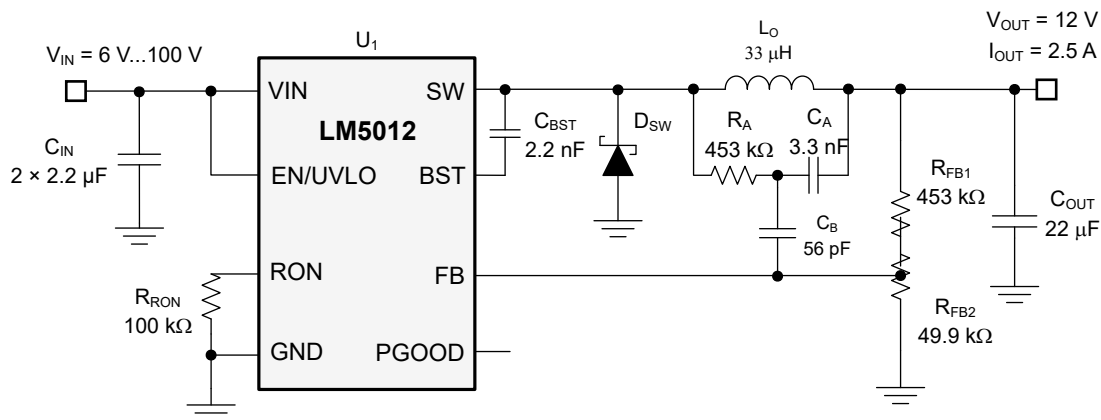

Figure 9-1. Typical Application, $V_{IN(nom)} = 48\text{ V}$, $V_{OUT} = 12\text{ V}$, $I_{OUT(max)} = 2.5\text{ A}$, $f_{SW(nom)} = 300\text{ kHz}$

Note

This and subsequent design examples are provided herein to showcase the LM5012 converter in several different applications. Depending on the source impedance of the input supply bus, an electrolytic capacitor can be required at the input to ensure stability, particularly at low input voltage and high output current operating conditions. See the [Power Supply Recommendations](#) section for more details.

9.2.1 Design Requirements

The target full-load efficiency is 92% based on a nominal input voltage of 48 V and an output voltage of 12 V. The required input voltage range is 15 V to 100 V. The switching frequency is set by resistor R_{ON} at 300 kHz. The output voltage soft-start time is 3 ms. Refer to [Detailed Design procedure](#) for more details on component selection.

9.2.2 Detailed Design Procedure

9.2.2.1 Custom Design With WEBENCH® Tools

Click [here](#) to create a custom design using the LM5163 device with the WEBENCH® Power Designer.

1. Start by entering the input voltage (V_{IN}), output voltage (V_{OUT}), and output current (I_{OUT}) requirements.
2. Optimize the design for key parameters such as efficiency, footprint, and cost using the optimizer dial.

The WEBENCH Power Designer provides a customized schematic along with a list of materials with real-time pricing and component availability.

In most cases, these actions are available:

- Run electrical simulations to see important waveforms and circuit performance
- Run thermal simulations to understand board thermal performance
- Export customized schematic and layout into popular CAD formats
- Print PDF reports for the design, and share the design with colleagues

Get more information about WEBENCH tools at www.ti.com/WEBENCH.

9.2.2.2 Switching Frequency (R_{RON})

The switching frequency of the LM5012 is set by the on-time programming resistor placed at R_{ON} . As shown by [Equation 7](#), a standard 100-k Ω , 1% resistor sets the switching frequency at 300 kHz.

$$R_{RON}(\text{k}\Omega) = \frac{V_{OUT}(\text{V}) \cdot 2500}{F_{SW}(\text{kHz})} \quad (7)$$

Note that at very low duty cycles, the 50-ns minimum controllable on time of the high-side MOSFET, $t_{ON(\text{min})}$, limits the maximum switching frequency. In CCM, $t_{ON(\text{min})}$ limits the voltage conversion step-down ratio for a given switching frequency. Use [Equation 8](#) to calculate the minimum controllable duty cycle.

$$D_{MIN} = t_{ON(\text{min})} \cdot F_{SW} \quad (8)$$

Ultimately, the choice of switching frequency for a given output voltage affects the available input voltage range, solution size, and efficiency. Use [Equation 9](#) to calculate the maximum supply voltage for a given $t_{ON(\text{min})}$ before switching frequency reduction occurs.

$$V_{IN(\text{max})} = \frac{V_{OUT}}{t_{ON(\text{min})} \cdot F_{SW}} \quad (9)$$

9.2.2.3 Buck Inductor (L_O)

Use [Equation 10](#) and [Equation 11](#) to calculate the inductor ripple current (assuming CCM operation) and peak inductor current, respectively.

$$\Delta I_L = \frac{V_{OUT}}{F_{SW} \cdot L_O} \cdot \left(1 - \frac{V_{OUT}}{V_{IN}}\right) \quad (10)$$

$$I_{L(\text{peak})} = I_{OUT(\text{max})} + \frac{\Delta I_L}{2} \quad (11)$$

For most applications, choose an inductance such that the inductor ripple current, ΔI_L , is between 30% and 50% of the rated load current at nominal input voltage. Use [Equation 12](#) to calculate the inductance.

$$L_O = \frac{V_{OUT}}{F_{SW} \cdot \Delta I_L} \cdot \left(1 - \frac{V_{OUT}}{V_{IN(nom)}} \right) \quad (12)$$

For applications in which the device must support input transients exceeding 72 V, select the inductor to be at least 22 μ H, which ensures that excessive current rise does not occur in the power stage due to the potential large inductor current slew during in an output short-circuit condition.

Choosing a 120- μ H inductor in this design results in 250-mA peak-to-peak ripple current at a nominal input voltage of 48 V, equivalent to 50% of the 500-mA rated load current. For designs that must operate up to the maximum input voltage at the full-rated load current of 2.5 A, the inductance must increase to ensure current limit (I_{PEAK} current limit) is not hit.

Check the inductor data sheet to make sure the saturation current of the inductor is well above the current limit setting of the LM5012. TI recommends that the saturation current to be greater than 5 A. Ferrite-core inductors have relatively lower core losses and are preferred at high switching frequencies, but exhibit a hard saturation characteristic – the inductance collapses abruptly when the saturation current is exceeded. This results in an abrupt increase in inductor ripple current, higher output voltage ripple, and reduced efficiency, in turn compromising reliability. Note that inductor saturation current levels generally decrease as the core temperature increases.

9.2.2.4 Schottky Diode (D_{SW})

The breakdown voltage rating of the diode is preferred to be 25% higher than the maximum input voltage. In the target application, the power rating for the diode must exceed the maximum DC output current and support the peak current limit (I_{PEAK} current limit) for best reliability in most applications.

For example, the LM5012EVM uses the V8P12-M3/86-A Schottky diode. The 120-V breakdown voltage rating and 8-A current rating ensure that the design can support a 100-V input and a short-circuit condition without any reliability concern. Furthermore, being that it is a Schottky diode with a low forward voltage and has small switching losses due to its low junction capacitance, the efficiency figure of the design can be optimized. With what loss does occur in the device, the package of the diode must be selected so it can have good heat conduction out of it into the copper ground plane.

9.2.2.5 Output Capacitor (C_{OUT})

Select a ceramic output capacitor to limit the capacitive voltage ripple at the converter output. This is the sinusoidal ripple voltage that is generated from the triangular inductor current ripple flowing into and out of the capacitor. Select an output capacitance using [Equation 13](#) to limit the voltage ripple component to 0.5% of the output voltage.

$$C_{OUT} \geq \frac{\Delta I_L}{8 \cdot F_{SW} \cdot V_{OUT(ripple)}} \quad (13)$$

Substituting $\Delta I_{L(nom)}$ of 250 mA gives C_{OUT} greater than 3.1 μ F. With voltage coefficients of ceramic capacitors taken in consideration, a 22- μ F, 25-V rated capacitor with X7R dielectric is selected.

9.2.2.6 Input Capacitor (C_{IN})

An input capacitor is necessary to limit the input ripple voltage while providing AC current to the buck power stage at every switching cycle. To minimize the parasitic inductance in the switching loop, position the input capacitors as close as possible to the VIN and GND pins of the LM5012. The input capacitors conduct a square-wave current of peak-to-peak amplitude equal to the output current. It follows that the resultant capacitive component of AC ripple voltage is a triangular waveform.

Along with the ESR-related ripple component, use [Equation 14](#) to calculate the peak-to-peak ripple voltage amplitude.

$$V_{IN(ripple)} = \frac{I_{OUT} \cdot D \cdot (1-D)}{F_{SW} \cdot C_{IN}} + I_{OUT} \cdot R_{ESR} \quad (14)$$

Use [Equation 15](#) to calculate the input capacitance required for a load current, based on an input voltage ripple specification (ΔV_{IN}).

$$C_{IN} \geq \frac{I_{OUT} \cdot D \cdot (1-D)}{F_{SW} \cdot (V_{IN(ripple)} - I_{OUT} \cdot R_{ESR})} \quad (15)$$

The recommended high-frequency input capacitance is 4.4 μ F or higher. Ensure the input capacitor is a high-quality X7S or X7R ceramic capacitor with sufficient voltage rating for C_{IN} . Based on the voltage coefficient of ceramic capacitors, choose a voltage rating preferably twice the maximum input voltage. Additionally, some bulk capacitance can be required for large input loop inductance or long wire harnesses used in the system. This capacitor provides parallel damping to the resonance associated with parasitic inductance of the supply lines and high-Q ceramics. See the [Power Supply Recommendations](#) section for more detail.

9.2.2.7 Type 3 Ripple Network

A Type 3 ripple generation network uses an RC filter consisting of R_A and C_A across SW and V_{OUT} to generate a triangular ramp that is in phase with the inductor current. This triangular ramp is then AC-coupled into the feedback node using capacitor C_B as shown in [Figure 9-1](#). Type 3 ripple injection is suited for applications where low output voltage ripple is crucial.

Use [Equation 16](#) and [Equation 17](#) to calculate R_A and C_A to provide the required ripple amplitude at the FB pin.

$$C_A \geq \frac{10}{F_{SW} \cdot (R_{FB1} \parallel R_{FB2})} \quad (16)$$

For the feedback resistor $R_{FBT} = 453 \text{ k}\Omega$ and $R_{FBB} = 49.9 \text{ k}\Omega$ values shown in [Figure 9-1](#), [Equation 16](#) dictates a minimum C_A of 742 pF. In this design, a 3300-pF capacitance is chosen, which is done to keep R_A within practical limits between 100 k Ω and 1 M Ω when using [Equation 17](#).

$$R_a \times C_a \leq \frac{(V_{IN(nom)} - V_{OUT}) \times t_{ON(nom)}}{20\text{mV}} \quad (17)$$

Based on C_A set at 3.3 nF, R_A is calculated to be 226 k Ω to provide a 20-mV ripple voltage at FB. The general recommendation for a Type 3 network is to calculate R_A and C_A to get 20 mV of ripple at typical operating conditions. A smaller R_A can need to be used to operate below nominal 48-V input. 12 mV of FB ripple or more must be ensured at the minimum input voltage of the design to ensure stability.

While the amplitude of the generated ripple does not affect the output voltage ripple, it impacts the output regulation as it reflects as a DC error of approximately half the amplitude of the generated ripple. For example, a converter circuit with Type 3 network that generates a 40-mV ripple voltage at the feedback node has approximately 10-mV worse load regulation scaled up through the FB divider to V_{OUT} than the same circuit that generates a 20-mV ripple at FB. Use [Equation 18](#) to calculate the coupling capacitance C_B .

$$C_B \geq \frac{t_{TR\text{-settling}}}{3 \cdot R_{FB1}} \quad (18)$$

where

- $t_{TR\text{-settling}}$ is the desired load transient response settling time.

C_B calculates to 56 pF based on a 75- μ s settling time. This value avoids excessive coupling capacitor discharge by the feedback resistors during sleep intervals when operating at light loads. To avoid capacitance fall-off with DC bias, use a C0G or NP0 dielectric capacitor for C_B .

9.2.3 Application Curves

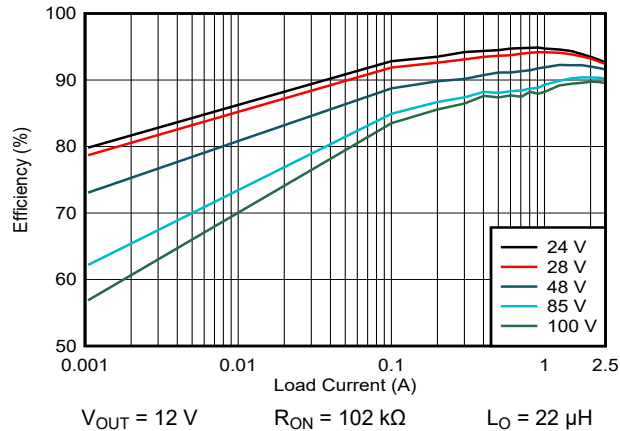

Figure 9-2. Conversion Efficiency (Log Scale)

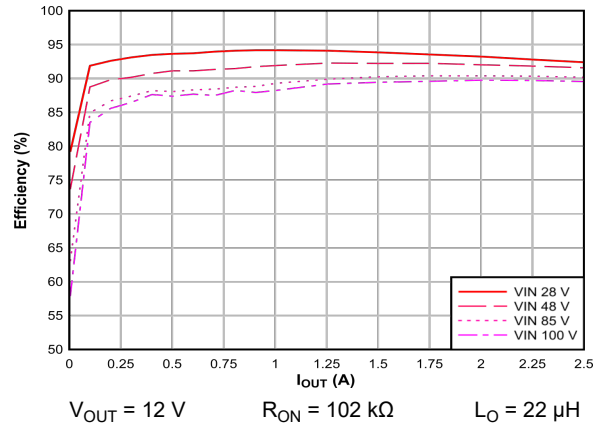

Figure 9-3. Conversion Efficiency (Linear Scale)

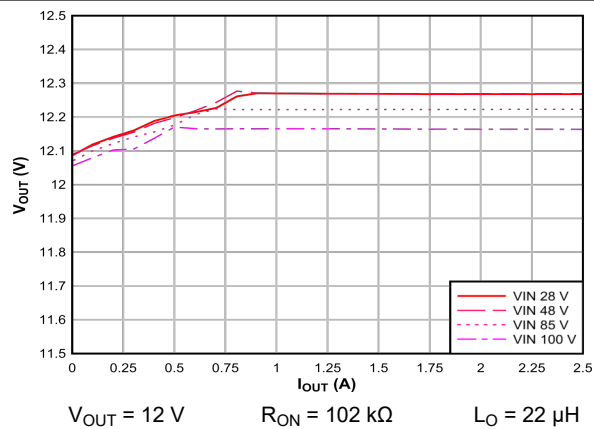

Figure 9-4. Load and Line Regulation Performance

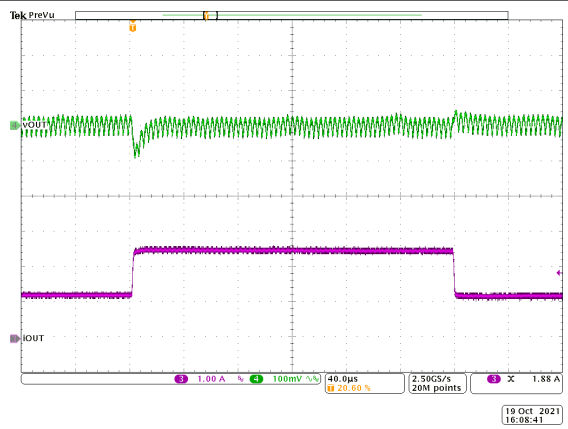

Figure 9-5. Load Step Response

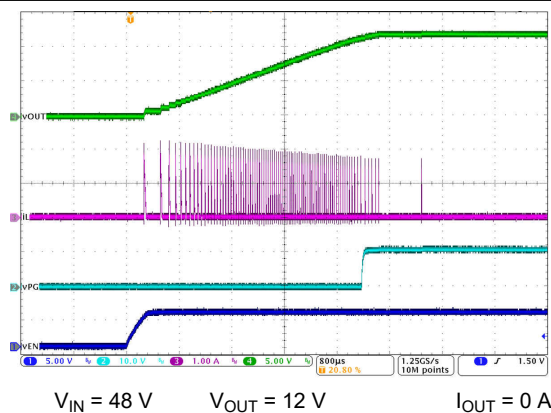

Figure 9-6. No-Load Start-Up with EN/UVLO

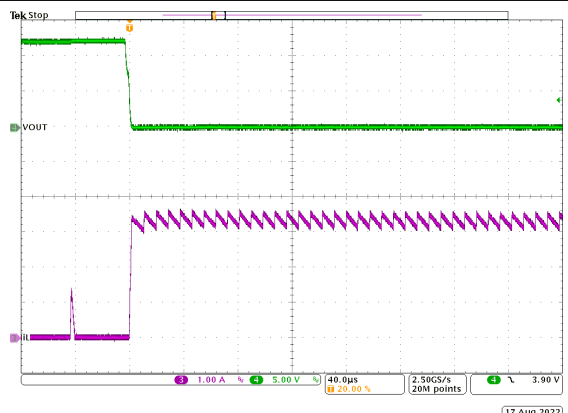
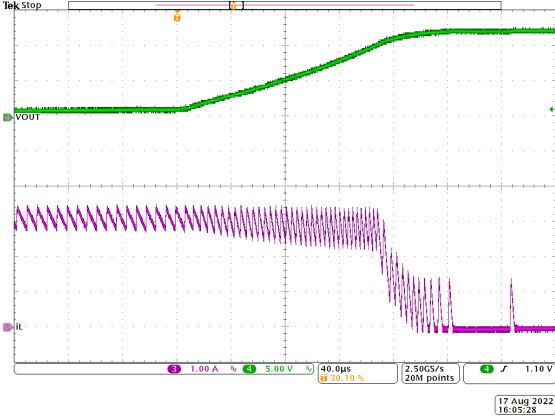
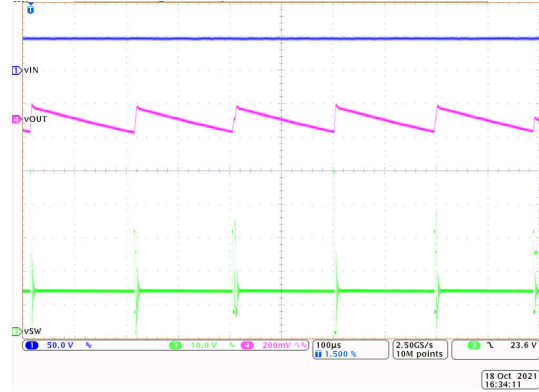

Figure 9-7. Short Circuit Applied



$V_{IN} = 48\text{ V}$ $V_{OUT} = 12\text{ V}$ Load = 0 A to Short

Figure 9-8. Short-Circuit Recovery



$V_{IN} = 48\text{ V}$ $V_{OUT} = 12\text{ V}$ $I_{OUT} = 200\text{ mA}$

Figure 9-9. Light-Load Switching

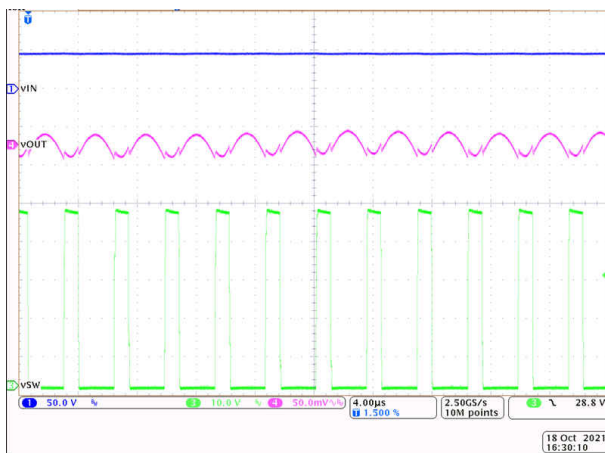

$V_{IN} = 48\text{ V}$ $V_{OUT} = 12\text{ V}$ $I_{OUT} = 2.5\text{ A}$

Figure 9-10. Full-Load Switching

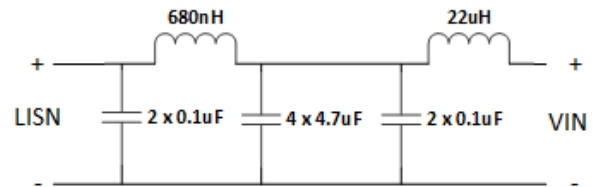

Filter used for EMC scan. Additionally, the regulator was housed in an enclosed shield.

Figure 9-11. Suggested EMC Filter for CISPR 25 Class 5 Compliance

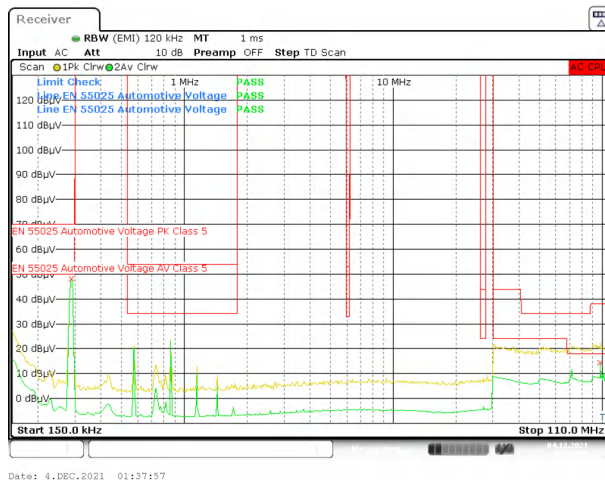

$V_{IN} = 48\text{ V}$

$V_{OUT} = 12\text{ V}$

$I_{OUT} = 3.5\text{ A}$
(LM5013-Q1)

Figure 9-12. CISPR 25 Class 5 Conducted Emissions Plot, 150 kHz to 110 MHz

9.3 Power Supply Recommendations

The LM5012 buck converter is designed to operate from a wide input voltage range between 6 V and 100 V. In addition, the input supply must be capable of delivering the required input current to the fully loaded regulator. Use [Equation 19](#) to estimate the average input current.

$$I_{IN} = \frac{V_{OUT} \cdot I_{OUT}}{V_{IN} \cdot \eta} \quad (19)$$

where

- η is the efficiency.

If the converter is connected to an input supply through long wires or PCB traces with a large impedance, take special care to achieve stable performance. The parasitic inductance and resistance of the input cables can have an adverse effect on converter operation. The parasitic inductance in combination with the low-ESR ceramic input capacitors form an underdamped resonant circuit. This circuit can cause overvoltage transients at VIN each time the input supply is cycled ON and OFF. The parasitic resistance causes the input voltage to dip during a load transient. If the converter is operating close to the minimum input voltage, this dip can cause false UVLO fault triggering and a system reset, in addition to potential stability issues. The circuit can be damped with a "parallel damping network." For example, a 22- μ F damping capacitor in series with a 1.4- Ω resistor connected to the VIN node creates a parallel damped network, providing sufficient damping for a 8.2- μ H input filter inductor and 4.4- μ F ceramic input capacitance. Damping is not only needed for an input EMC filter, but also when the application uses a power harness which can present a large input loop inductance. For example, two cables (one for VIN and one for GND), each 1 meter (approximately 3 feet) long with approximately 1-mm diameter (18 AWG), placed 1 cm (approximately 0.4 inch) apart forms a rectangular loop resulting in approximately 1.2 μ H of inductance. The [Input Filter Design for Switching Power Supplies](#) application report provides more detail on this topic.

An EMI input filter is often used in front of the regulator that, unless carefully designed, can lead to instability as well as some of the effects mentioned above. The [Simple Success with Conducted EMI for DC-DC Converters](#) application report provides helpful suggestions when designing an input filter for any switching regulator.

9.4 Layout

9.4.1 Layout Guidelines

PCB layout is a critical portion of good-power supply design. There are several paths that conduct high slew-rate currents or voltages that can interact with stray inductance or parasitic capacitance to generate noise and EMI or degrade the power supply performance.

- To help eliminate these problems, bypass the VIN pin to GND with a low-ESR ceramic bypass capacitor with a high-quality dielectric. Place C_{IN} as close as possible to the LM5012 VIN and GND pins. Grounding for both the input and output capacitors must consist of localized top-side planes that connect to the GND pin and GND PAD.
- Minimize the loop area formed by the input capacitor connections to the VIN and GND pins.
- Place the inductor and Schottky diode close to the SW pin. Minimize the area of the SW trace or plane to prevent excessive capacitive coupling.
- Have the Schottky diode anode pin in close proximity to input capacitor ground or return.
- Tie the GND pin directly to the power pad under the device and to a heat-sinking PCB ground plane.
- Use a ground plane in one of the middle layers as a noise shielding and heat dissipation path.
- Have a single-point ground connection to the plane. Route the ground connections for the feedback, soft start, and enable components to the ground plane, which prevents any switched or load currents from flowing in analog ground traces. If not properly handled, poor grounding results in degraded load regulation or erratic output voltage ripple behavior.
- Make V_{IN} , V_{OUT} , and ground bus connections as wide as possible, which reduces any voltage drops on the input or output paths of the converter and maximizes efficiency.

- Minimize trace length to the FB pin. Place both feedback resistors, R_{FB1} and R_{FB2} , close to the FB pin. Place C_{FF} (if needed) directly in parallel with R_{FB1} . If output setpoint accuracy at the load is important, connect the V_{OUT} sense at the load. Route the V_{OUT} sense path away from noisy nodes and preferably through a layer on the other side of a grounded shielding layer.
- The RON pin is sensitive to noise. Thus, locate the R_{RON} resistor as close as possible to the device and route with minimal lengths of trace. The parasitic capacitance from RON to GND must not exceed 20 pF.
- Provide adequate heat sinking for the LM5012 to keep the junction temperature below 150°C. For operation at full rated load, the top-side ground plane is an important heat-dissipating area. Use an array of heat-sinking vias to connect the exposed pad to the PCB ground plane. If the PCB has multiple copper layers, these thermal vias must also be connected to inner layer heat-spreading ground planes.
- Reference [Layout Example](#).

9.4.1.1 Compact PCB Layout for EMI Reduction

Radiated EMI generated by high di/dt components relates to pulsing currents in switching converters. The larger area covered by the path of a pulsing current, the more electromagnetic emission is generated. The key to minimizing radiated EMI is to identify the pulsing current path and minimize the area of that path.

Figure 9-13 denotes the critical switching loop of the buck converter power stage in terms of EMI. The topological architecture of a buck converter means that a particularly high di/dt current path exists in the loop comprising the input capacitor and the integrated MOSFETs of the LM5012, and it becomes mandatory to reduce the parasitic inductance of this loop by minimizing the effective loop area.

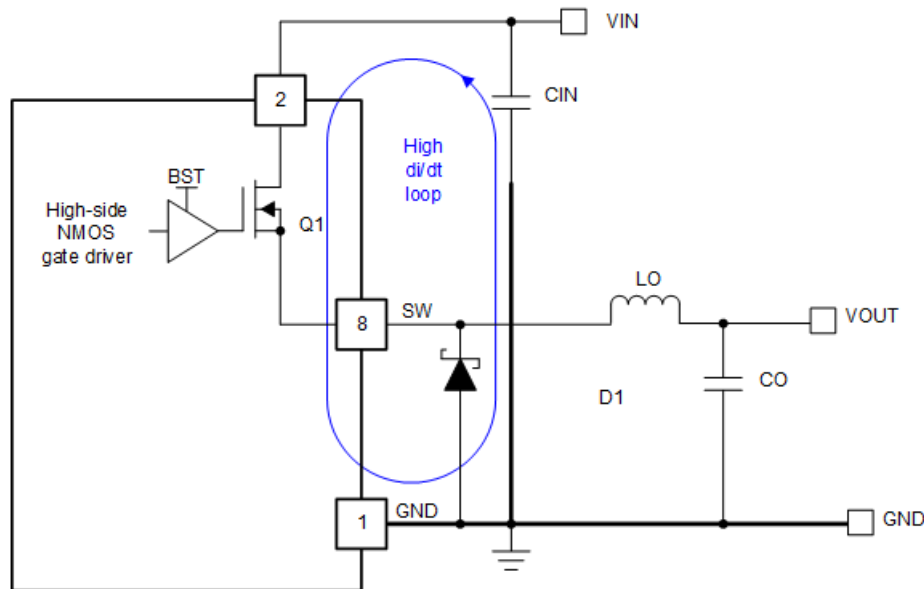

Figure 9-13. DC/DC Buck Converter With Power Stage Circuit Switching Loop

The input capacitor provides the primary path for the high di/dt components of the current of the high-side MOSFET. Placing a ceramic capacitor as close as possible to the VIN and GND pins is the key to EMI reduction. Keep the trace connecting SW to the inductor as short as possible and just wide enough to carry the load current without excessive heating. Use short, thick traces or copper pours (shapes) for current conduction path to minimize parasitic resistance. Place the output capacitor close to the V_{OUT} side of the inductor, and connect the return pin of the capacitor to the GND pin and exposed PAD of the LM5012.

9.4.1.2 Feedback Resistors

Reduce noise sensitivity of the output voltage feedback path by placing the resistor divider close to the FB pin, rather than close to the load, which reduces the trace length of FB signal and noise coupling. The FB pin is the input to the feedback comparator, and as such, is a high impedance node sensitive to noise. The output node is a low impedance node, so the trace from V_{OUT} to the resistor divider can be long if a short path is not available.

Route the voltage sense trace from the load to the feedback resistor divider, keeping away from the SW node, the inductor, and V_{IN} to avoid contaminating the feedback signal with switch noise, while also minimizing the trace length. This is most important when high feedback resistances greater than 100 k Ω are used to set the output voltage. Also, route the voltage sense trace on a different layer from the inductor, SW node, and V_{IN} so there is a ground plane that separates the feedback trace from the inductor and SW node copper polygon, which provides further shielding for the voltage feedback path from switching noise sources.

9.4.2 Layout Example

Figure 9-14 shows an example layout for the PCB top layer of a 2-layer board with essential components placed on the top side.

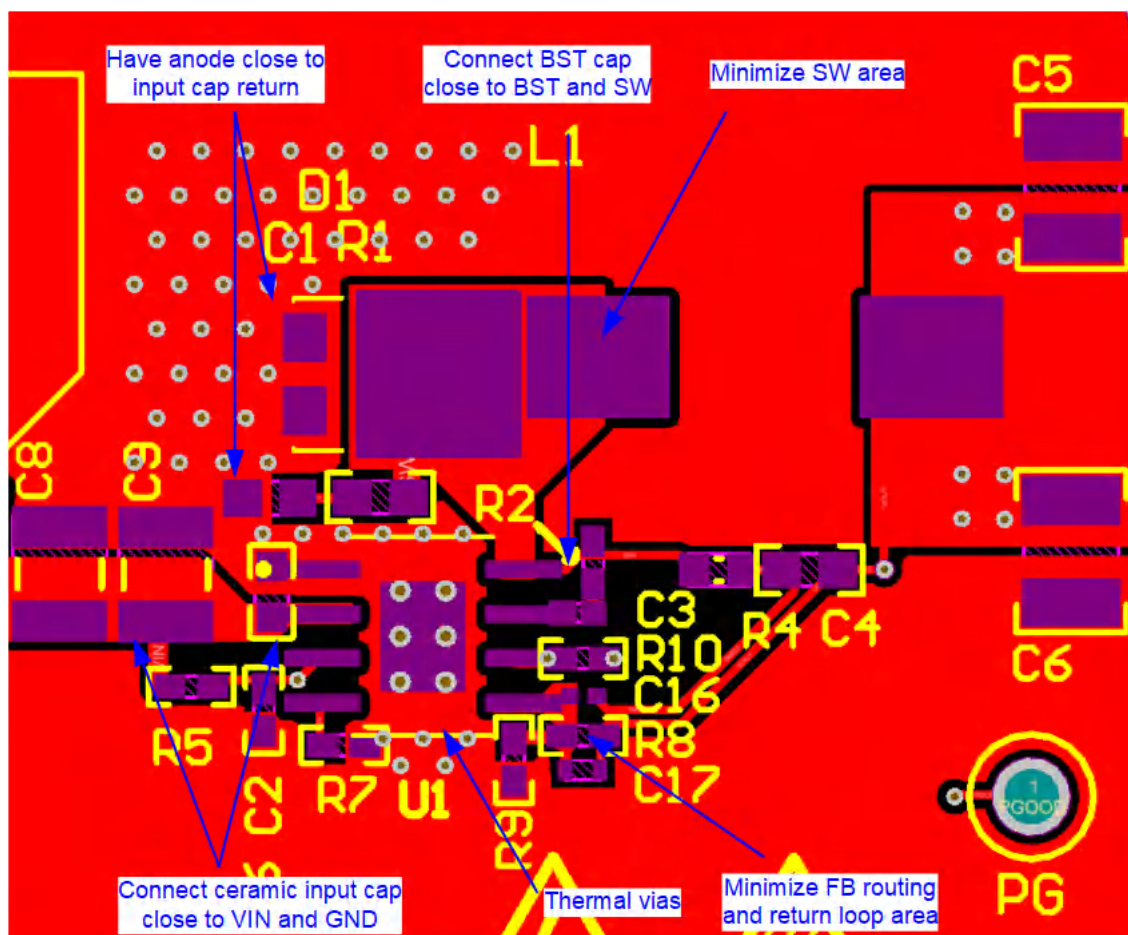

Figure 9-14. LM5012 Layout Example

9.4.2.1 Thermal Considerations

As with any power conversion device, the LM5012 dissipates internal power while operating. The effect of this power dissipation is to raise the internal temperature of the converter above ambient. The internal die temperature (T_J) is a function of the following:

- Ambient temperature
- Power loss
- Effective thermal resistance, $R_{\theta JA}$, of the device
- PCB combination

The maximum internal die temperature for the LM5012 must be limited to 150°C. This limit establishes a limit on the maximum device power dissipation and, therefore, the load current. Equation 20 shows the relationships between the important parameters. It is easy to see that larger ambient temperatures (T_A) and larger values

of $R_{\theta JA}$ reduce the maximum available output current. The converter efficiency can be estimated by using the curves provided in this data sheet. Note that these curves include the power loss in the inductor. If the desired operating conditions cannot be found in one of the curves, then interpolation can be used to estimate the efficiency. Alternatively, the EVM can be adjusted to match the desired application requirements and the efficiency can be measured directly. The correct value of $R_{\theta JA}$ is more difficult to estimate. As stated in the [Semiconductor and IC Package Thermal Metrics](#) application report, the value of $R_{\theta JA}$ given in the [Thermal Information](#) is not valid for design purposes and must not be used to estimate the thermal performance of the application. The values reported in that table were measured under a specific set of conditions that are rarely obtained in an actual application. The data given for $R_{\theta JC(bott)}$ and Ψ_{JT} can be useful when determining thermal performance. See the [Semiconductor and IC Package Thermal Metrics](#) application report for more information and the resources given at the end of this section.

$$I_{OUT}|_{MAX} = \frac{(T_J - T_A)}{R_{\theta JA}} \cdot \frac{\eta}{(1 - \eta)} \cdot \frac{1}{V_{OUT}} \tag{20}$$

where

- η is efficiency.

The effective $R_{\theta JA}$ is a critical parameter and depends on many factors such as the following:

- Power dissipation
- Air temperature/flow
- PCB area
- Copper heat-sink area
- Number of thermal vias under the package
- Adjacent component placement

The LM5012 features a die attach paddle, or "thermal pad" (EP), to provide a place to solder down to the PCB heat-sinking copper. This feature provides a good heat conduction path from the regulator junction to the heat sink and must be properly soldered to the PCB heat sink copper. Typical examples of $R_{\theta JA}$ can be found in [Figure 9-15](#). The copper area given in the graph is for each layer. The top and bottom layers are 2-oz. copper each, while the inner layers are 1 oz. Remember that the data given in this graph is for illustration purposes only, and the actual performance in any given application depends on all of the previously mentioned factors.

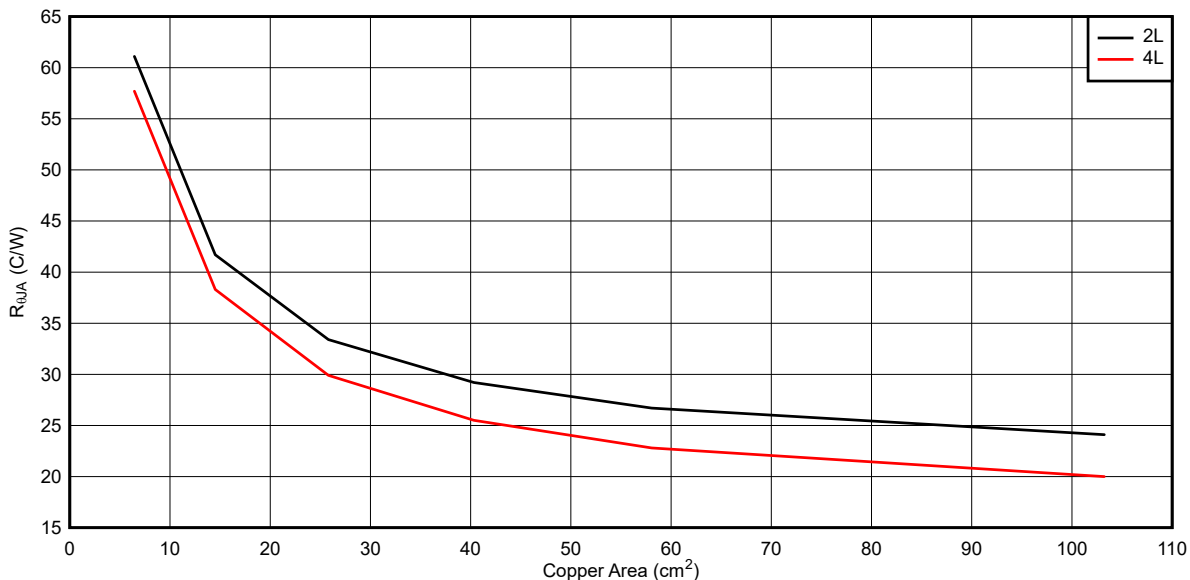

Figure 9-15. Typical $R_{\theta JA}$ vs Copper Area

To continue with the design example, assume that the user has an ambient temperature of 70°C and wishes to estimate the required copper area to keep the device junction temperature below 125°C, at full load. From the

curves in [Figure 9-3](#), an efficiency of about 92% was found at an input voltage of 48 V with output of 12 V with 1.75-A load. The efficiency is somewhat less at high junction temperatures, so an efficiency of approximately 90% is assumed. This gives a total loss of about 2.3 W. Subtracting out the conduction loss alone for the inductor and catch diode, the user arrives at a device dissipation of about 1.54 W. With this information, the user can calculate the required $R_{\theta JA}$ of about 30°C/W. Based on [Figure 9-15](#), the required copper area is about 40 cm², for a two-layer PCB.

Engineering best judgment is to be used if using a lossy inductor, diode, or both, in the application, as their large losses may contribute to localized heating of the component, as well, the nearby regulator. As an example, biasing the Schottky diode (D_{SW}) with 1.3-A continuous current (average current for 1.75-A load current) results in approximately 10°C rise in the case temperature of the regulator. This must be "buffered" for in the ambient temperature used in the previous calculation. For more details on these calculations, please see the [PCB Thermal Design Tips for Automotive DC/DC Converters](#) application report.

The following resources can be used as a guide to optimal thermal PCB design and estimating $R_{\theta JA}$ for a given application environment:

- [Semiconductor and IC Package Thermal Metrics](#) application report
- [AN-2020 Thermal Design By Insight, Not Hindsight](#) application report
- [A Guide to Board Layout for Best Thermal Resistance for Exposed Pad Packages](#) application report
- [Using New Thermal Metrics](#) application report
- [PCB Thermal Design Tips for Automotive DC/DC Converters](#) application report

10 Device and Documentation Support

10.1 Device Support

10.1.1 Third-Party Products Disclaimer

TI'S PUBLICATION OF INFORMATION REGARDING THIRD-PARTY PRODUCTS OR SERVICES DOES NOT CONSTITUTE AN ENDORSEMENT REGARDING THE SUITABILITY OF SUCH PRODUCTS OR SERVICES OR A WARRANTY, REPRESENTATION OR ENDORSEMENT OF SUCH PRODUCTS OR SERVICES, EITHER ALONE OR IN COMBINATION WITH ANY TI PRODUCT OR SERVICE.

10.1.2 Development Support

- [LM5014 Quickstart Calculator](#)
- [LM5014 Simulation Models](#)
- [TI Reference Design Library](#)
- Technical Articles:
 - [Use a Low-quiescent-current Switcher for High-voltage Conversion](#)
 - [Powering Smart Sensor Transmitters in Industrial Applications](#)
 - [Industrial Strength Design – Part 1](#)
 - [Trends in Building Automation: Predictive Maintenance](#)
 - [Trends in Building Automation: Connected Sensors for User Comfort](#)

10.1.2.1 Custom Design With WEBENCH® Tools

[Click here](#) to create a custom design using the LM5012 device with the WEBENCH® Power Designer.

1. Start by entering the input voltage (V_{IN}), output voltage (V_{OUT}), and output current (I_{OUT}) requirements.
2. Optimize the design for key parameters such as efficiency, footprint, and cost using the optimizer dial.
3. Compare the generated design with other possible solutions from Texas Instruments.

The WEBENCH Power Designer provides a customized schematic along with a list of materials with real-time pricing and component availability.

In most cases, these actions are available:

- Run electrical simulations to see important waveforms and circuit performance
- Run thermal simulations to understand board thermal performance
- Export customized schematic and layout into popular CAD formats
- Print PDF reports for the design, and share the design with colleagues

Get more information about WEBENCH tools at www.ti.com/WEBENCH.

10.2 Documentation Support

10.2.1 Related Documentation

For related documentation see the following:

- Texas Instruments, [LM5012/3/4/3/4-Q1EVM-041 EVM](#) user's guide
- Texas Instruments, [Selecting an Ideal Ripple Generation Network for Your COT Buck Converter](#) application report
- Texas Instruments, [Valuing Wide \$V_{IN}\$, Low-EMI Synchronous Buck Circuits for Cost-Effective, Demanding Applications](#) white paper
- Texas Instruments, [An Overview of Conducted EMI Specifications for Power Supplies](#) white paper
- Texas Instruments, [An Overview of Radiated EMI Specifications for Power Supplies](#) white paper
- Texas Instruments, [24-V AC Power Stage with Wide \$V_{IN}\$ Converter and Battery Gauge for Smart Thermostat](#) design guide
- Texas Instruments, [Accurate Gauging and 50- \$\mu\$ A Standby Current, 13S, 48-V Li-ion Battery Pack Reference](#) design guide
- Texas Instruments, [AN-2162: Simple Success with Conducted EMI from DC/DC Converters](#) application report
- Texas Instruments, [Powering Drones with a Wide \$V_{IN}\$ DC/DC Converter](#) application report
- Texas Instruments, [Using New Thermal Metrics](#) application report
- Texas Instruments, [Semiconductor and IC Package Thermal Metrics](#) application report

10.3 Receiving Notification of Documentation Updates

To receive notification of documentation updates, navigate to the device product folder on ti.com. Click on *Subscribe to updates* to register and receive a weekly digest of any product information that has changed. For change details, review the revision history included in any revised document.

10.4 Support Resources

TI E2E™ [support forums](#) are an engineer's go-to source for fast, verified answers and design help — straight from the experts. Search existing answers or ask your own question to get the quick design help you need.

Linked content is provided "AS IS" by the respective contributors. They do not constitute TI specifications and do not necessarily reflect TI's views; see TI's [Terms of Use](#).

10.5 Trademarks

PowerPAD™ and TI E2E™ are trademarks of Texas Instruments.

WEBENCH® is a registered trademark of Texas Instruments.

All trademarks are the property of their respective owners.

10.6 Electrostatic Discharge Caution



This integrated circuit can be damaged by ESD. Texas Instruments recommends that all integrated circuits be handled with appropriate precautions. Failure to observe proper handling and installation procedures can cause damage.

ESD damage can range from subtle performance degradation to complete device failure. Precision integrated circuits may be more susceptible to damage because very small parametric changes could cause the device not to meet its published specifications.

10.7 Glossary

[TI Glossary](#)

This glossary lists and explains terms, acronyms, and definitions.

11 Mechanical, Packaging, and Orderable Information

The following pages include mechanical packaging and orderable information. This information is the most current data available for the designated devices. This data is subject to change without notice and revision of this document. For browser-based versions of this data sheet, refer to the left-hand navigation.

PACKAGING INFORMATION

Orderable part number	Status (1)	Material type (2)	Package Pins	Package qty Carrier	RoHS (3)	Lead finish/ Ball material (4)	MSL rating/ Peak reflow (5)	Op temp (°C)	Part marking (6)
LM5012DDAR	Active	Production	SO PowerPAD (DDA) 8	2500 LARGE T&R	Yes	NIPDAU NIPDAUAG	Level-2-260C-1 YEAR	-40 to 150	L5012C
LM5012DDAR.A	Active	Production	SO PowerPAD (DDA) 8	2500 LARGE T&R	Yes	NIPDAU	Level-2-260C-1 YEAR	-40 to 150	L5012C

(1) **Status:** For more details on status, see our [product life cycle](#).

(2) **Material type:** When designated, preproduction parts are prototypes/experimental devices, and are not yet approved or released for full production. Testing and final process, including without limitation quality assurance, reliability performance testing, and/or process qualification, may not yet be complete, and this item is subject to further changes or possible discontinuation. If available for ordering, purchases will be subject to an additional waiver at checkout, and are intended for early internal evaluation purposes only. These items are sold without warranties of any kind.

(3) **RoHS values:** Yes, No, RoHS Exempt. See the [TI RoHS Statement](#) for additional information and value definition.

(4) **Lead finish/Ball material:** Parts may have multiple material finish options. Finish options are separated by a vertical ruled line. Lead finish/Ball material values may wrap to two lines if the finish value exceeds the maximum column width.

(5) **MSL rating/Peak reflow:** The moisture sensitivity level ratings and peak solder (reflow) temperatures. In the event that a part has multiple moisture sensitivity ratings, only the lowest level per JEDEC standards is shown. Refer to the shipping label for the actual reflow temperature that will be used to mount the part to the printed circuit board.

(6) **Part marking:** There may be an additional marking, which relates to the logo, the lot trace code information, or the environmental category of the part.

Multiple part markings will be inside parentheses. Only one part marking contained in parentheses and separated by a "-" will appear on a part. If a line is indented then it is a continuation of the previous line and the two combined represent the entire part marking for that device.

Important Information and Disclaimer: The information provided on this page represents TI's knowledge and belief as of the date that it is provided. TI bases its knowledge and belief on information provided by third parties, and makes no representation or warranty as to the accuracy of such information. Efforts are underway to better integrate information from third parties. TI has taken and continues to take reasonable steps to provide representative and accurate information but may not have conducted destructive testing or chemical analysis on incoming materials and chemicals. TI and TI suppliers consider certain information to be proprietary, and thus CAS numbers and other limited information may not be available for release.

In no event shall TI's liability arising out of such information exceed the total purchase price of the TI part(s) at issue in this document sold by TI to Customer on an annual basis.

OTHER QUALIFIED VERSIONS OF LM5012 :

- Automotive : [LM5012-Q1](#)

NOTE: Qualified Version Definitions:

- Automotive - Q100 devices qualified for high-reliability automotive applications targeting zero defects

TAPE AND REEL INFORMATION

QUADRANT ASSIGNMENTS FOR PIN 1 ORIENTATION IN TAPE

*All dimensions are nominal

Device	Package Type	Package Drawing	Pins	SPQ	Reel Diameter (mm)	Reel Width W1 (mm)	A0 (mm)	B0 (mm)	K0 (mm)	P1 (mm)	W (mm)	Pin1 Quadrant
LM5012DDAR	SO PowerPAD	DDA	8	2500	330.0	12.8	6.4	5.2	2.1	8.0	12.0	Q1

TAPE AND REEL BOX DIMENSIONS

*All dimensions are nominal

Device	Package Type	Package Drawing	Pins	SPQ	Length (mm)	Width (mm)	Height (mm)
LM5012DDAR	SO PowerPAD	DDA	8	2500	366.0	364.0	50.0

DDA0008B



PACKAGE OUTLINE

PowerPAD™ SOIC - 1.7 mm max height

PLASTIC SMALL OUTLINE

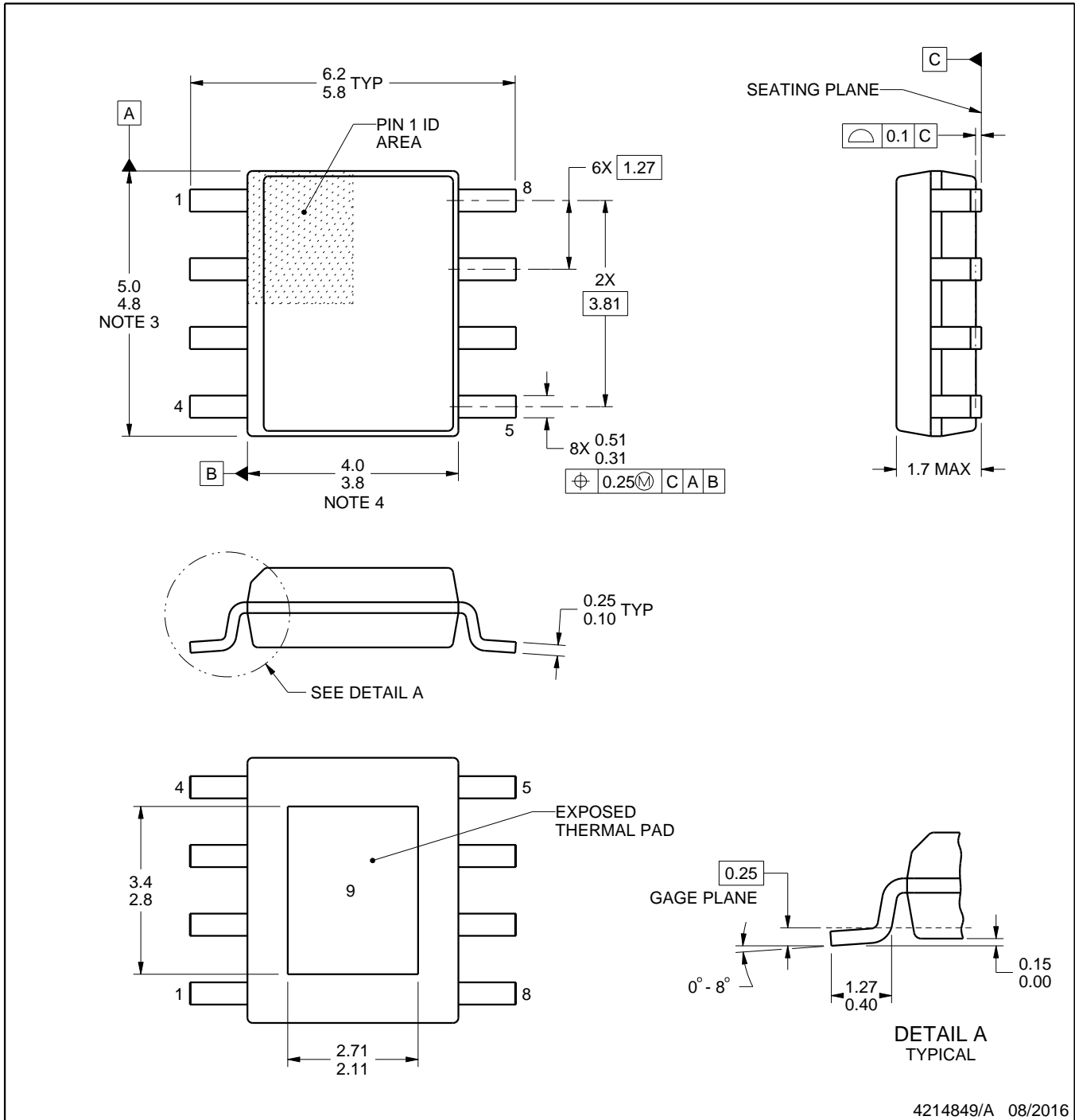

4214849/A 08/2016

NOTES:

PowerPAD is a trademark of Texas Instruments.

1. All linear dimensions are in millimeters. Any dimensions in parenthesis are for reference only. Dimensioning and tolerancing per ASME Y14.5M.
2. This drawing is subject to change without notice.
3. This dimension does not include mold flash, protrusions, or gate burrs. Mold flash, protrusions, or gate burrs shall not exceed 0.15 mm per side.
4. This dimension does not include interlead flash. Interlead flash shall not exceed 0.25 mm per side.
5. Reference JEDEC registration MS-012.

EXAMPLE BOARD LAYOUT

DDA0008B

PowerPAD™ SOIC - 1.7 mm max height

PLASTIC SMALL OUTLINE

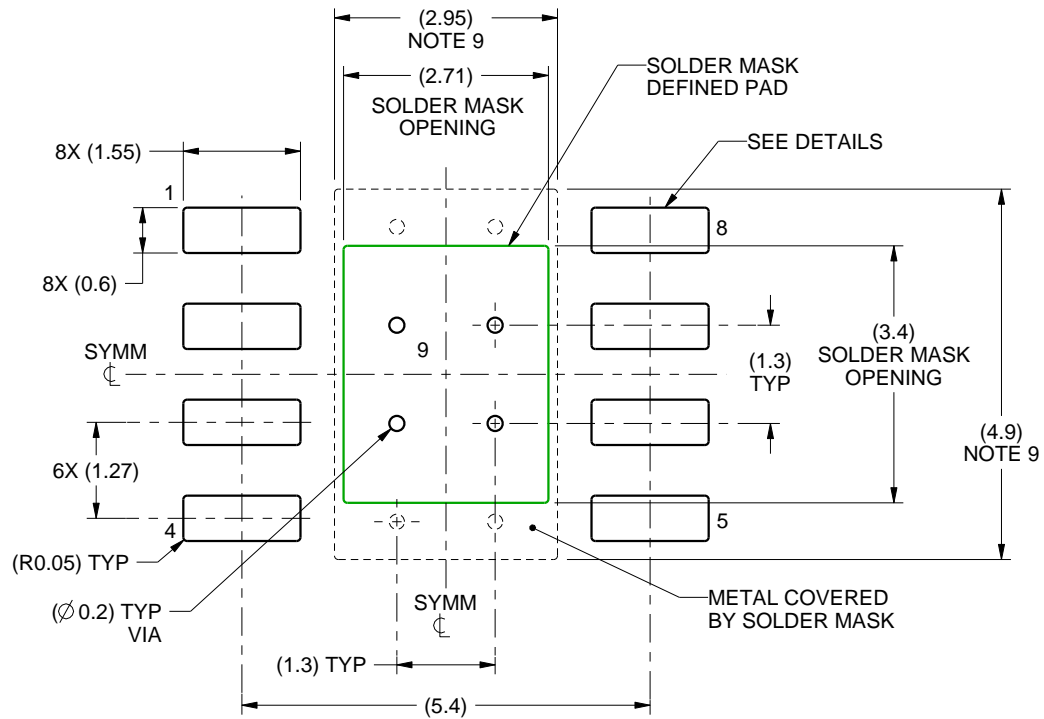

LAND PATTERN EXAMPLE
SCALE:10X

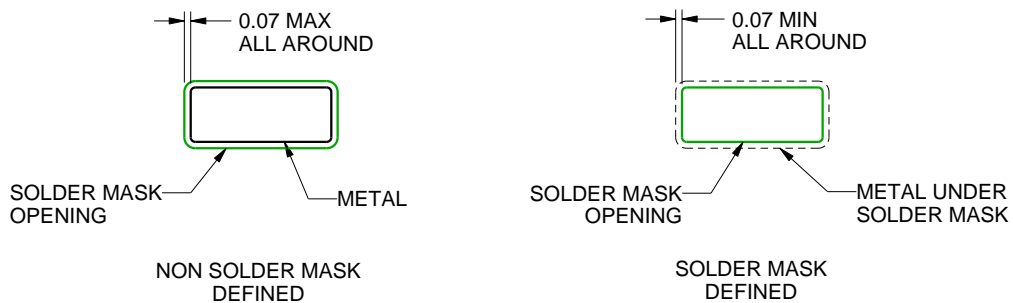

SOLDER MASK DETAILS
PADS 1-8

4214849/A 08/2016

NOTES: (continued)

6. Publication IPC-7351 may have alternate designs.
7. Solder mask tolerances between and around signal pads can vary based on board fabrication site.
8. This package is designed to be soldered to a thermal pad on the board. For more information, see Texas Instruments literature numbers SLMA002 (www.ti.com/lit/slma002) and SLMA004 (www.ti.com/lit/slma004).
9. Size of metal pad may vary due to creepage requirement.
10. Vias are optional depending on application, refer to device data sheet. If any vias are implemented, refer to their locations shown on this view. It is recommended that vias under paste be filled, plugged or tented.

EXAMPLE STENCIL DESIGN

DDA0008B

PowerPAD™ SOIC - 1.7 mm max height

PLASTIC SMALL OUTLINE

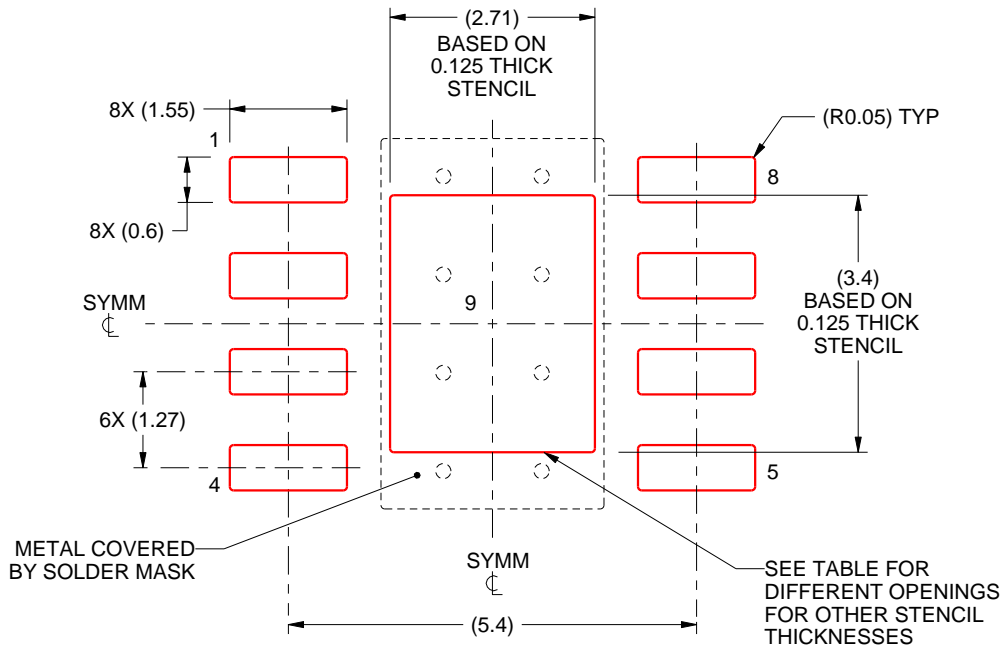

SOLDER PASTE EXAMPLE
 EXPOSED PAD
 100% PRINTED SOLDER COVERAGE BY AREA
 SCALE:10X

STENCIL THICKNESS	SOLDER STENCIL OPENING
0.1	3.03 X 3.80
0.125	2.71 X 3.40 (SHOWN)
0.150	2.47 X 3.10
0.175	2.29 X 2.87

4214849/A 08/2016

NOTES: (continued)

11. Laser cutting apertures with trapezoidal walls and rounded corners may offer better paste release. IPC-7525 may have alternate design recommendations.
12. Board assembly site may have different recommendations for stencil design.

DDA (R-PDSO-G8)

PowerPAD™ PLASTIC SMALL-OUTLINE

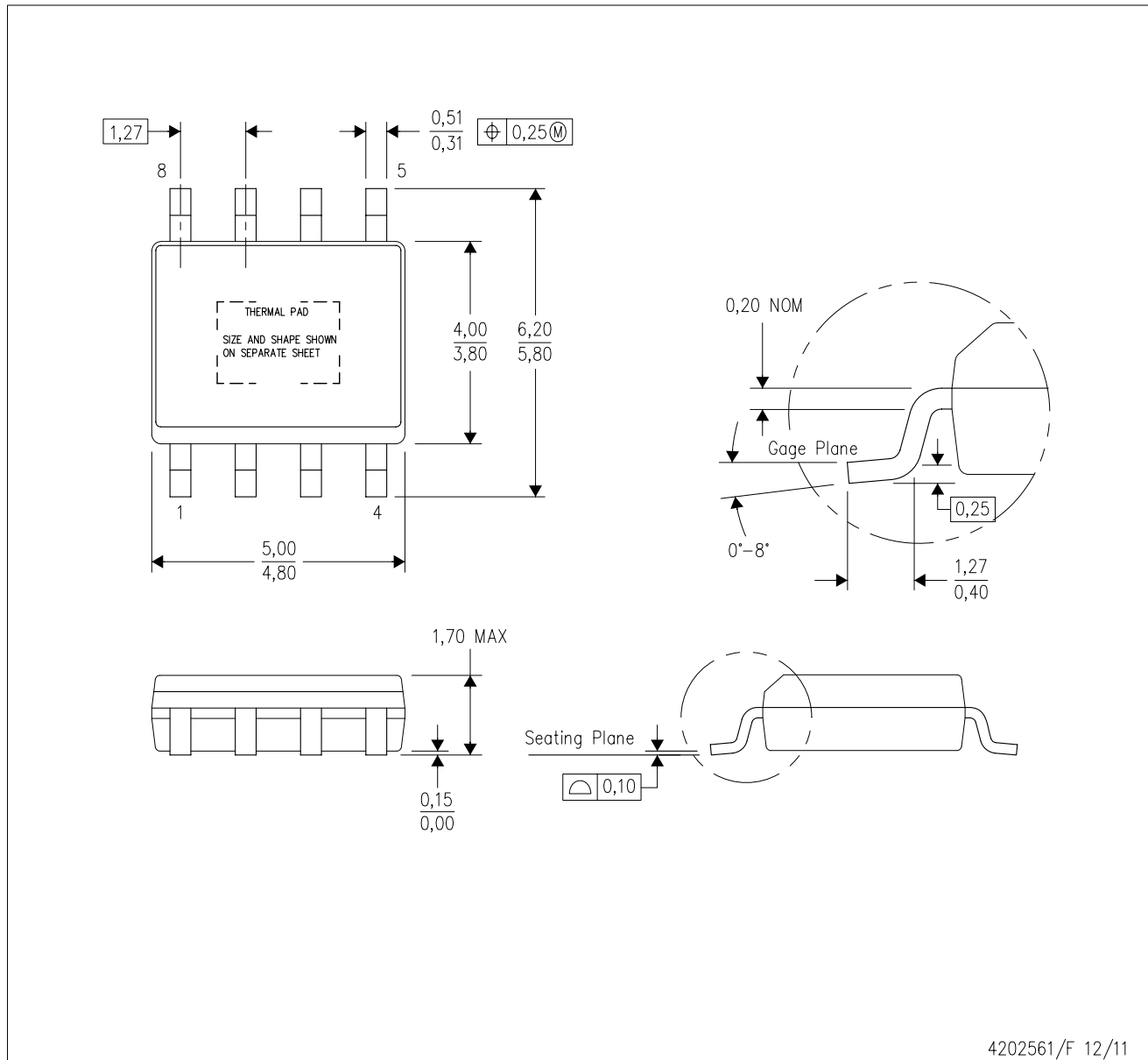

4202561/F 12/11

- NOTES:
- All linear dimensions are in millimeters. Dimensioning and tolerancing per ASME Y14.5-1994.
 - This drawing is subject to change without notice.
 - Body dimensions do not include mold flash or protrusion not to exceed 0,15.
 - This package is designed to be soldered to a thermal pad on the board. Refer to Technical Brief, PowerPad Thermally Enhanced Package, Texas Instruments Literature No. SLMA002 for information regarding recommended board layout. This document is available at www.ti.com <<http://www.ti.com>>.
 - See the additional figure in the Product Data Sheet for details regarding the exposed thermal pad features and dimensions.
 - This package complies to JEDEC MS-012 variation BA

PowerPAD is a trademark of Texas Instruments.

DDA (R-PDSO-G8)

PowerPAD™ PLASTIC SMALL OUTLINE

THERMAL INFORMATION

This PowerPAD™ package incorporates an exposed thermal pad that is designed to be attached to a printed circuit board (PCB). The thermal pad must be soldered directly to the PCB. After soldering, the PCB can be used as a heatsink. In addition, through the use of thermal vias, the thermal pad can be attached directly to the appropriate copper plane shown in the electrical schematic for the device, or alternatively, can be attached to a special heatsink structure designed into the PCB. This design optimizes the heat transfer from the integrated circuit (IC).

For additional information on the PowerPAD package and how to take advantage of its heat dissipating abilities, refer to Technical Brief, PowerPAD Thermally Enhanced Package, Texas Instruments Literature No. SLMA002 and Application Brief, PowerPAD Made Easy, Texas Instruments Literature No. SLMA004. Both documents are available at www.ti.com.

The exposed thermal pad dimensions for this package are shown in the following illustration.

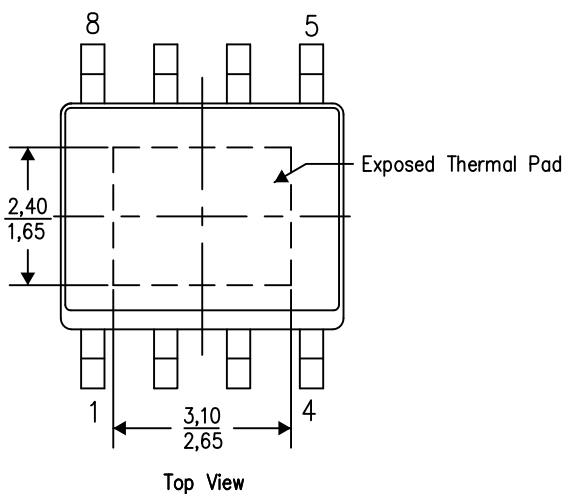

Exposed Thermal Pad Dimensions

4206322-6/L 05/12

NOTE: A. All linear dimensions are in millimeters

PowerPAD is a trademark of Texas Instruments

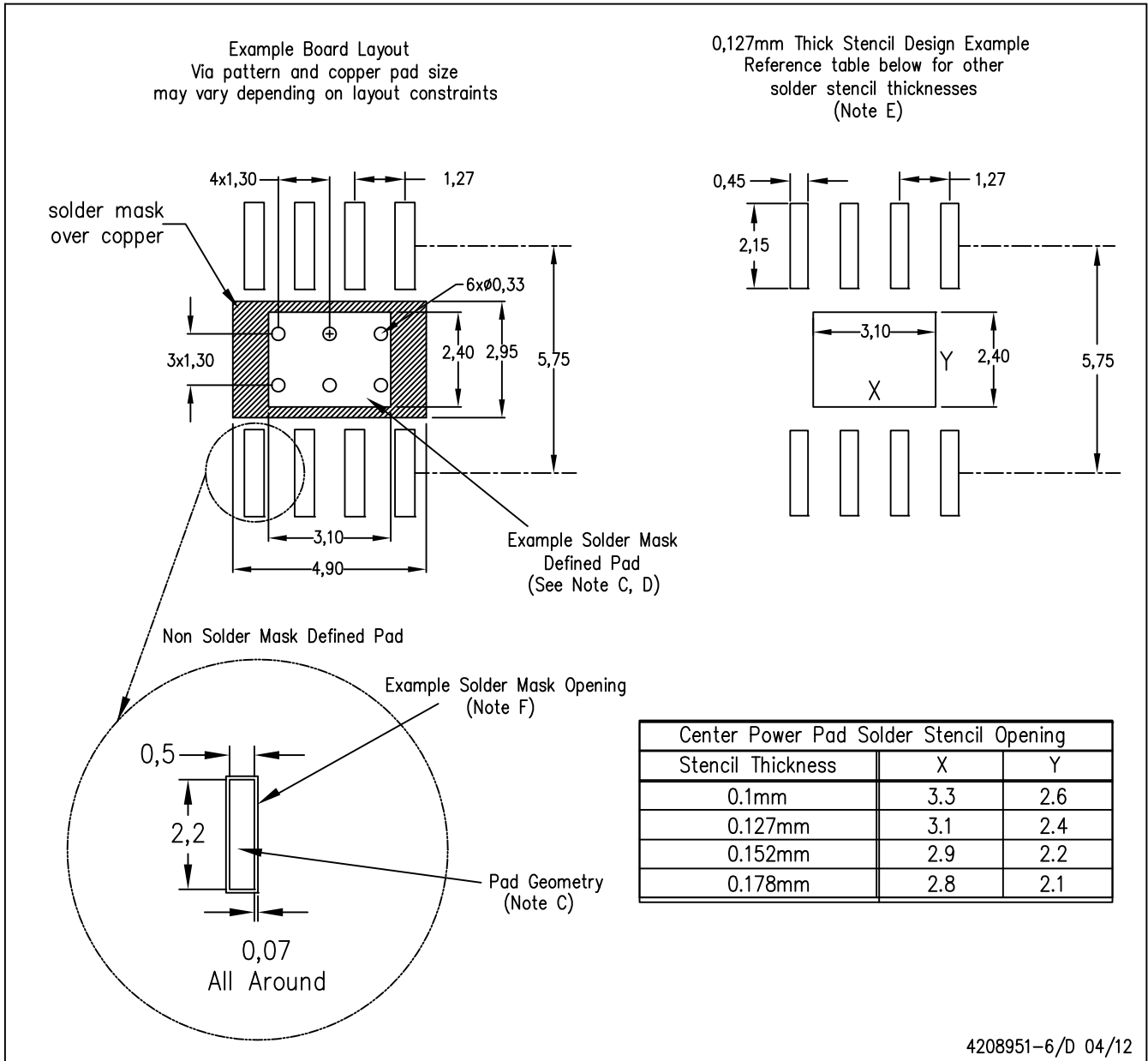

- NOTES:
- A. All linear dimensions are in millimeters.
 - B. This drawing is subject to change without notice.
 - C. Publication IPC-7351 is recommended for alternate designs.
 - D. This package is designed to be soldered to a thermal pad on the board. Refer to Technical Brief, PowerPad Thermally Enhanced Package, Texas Instruments Literature No. SLMA002, SLMA004, and also the Product Data Sheets for specific thermal information, via requirements, and recommended board layout. These documents are available at www.ti.com <<http://www.ti.com>>. Publication IPC-7351 is recommended for alternate designs.
 - E. Laser cutting apertures with trapezoidal walls and also rounding corners will offer better paste release. Customers should contact their board assembly site for stencil design recommendations. Example stencil design based on a 50% volumetric metal load solder paste. Refer to IPC-7525 for other stencil recommendations.
 - F. Customers should contact their board fabrication site for solder mask tolerances between and around signal pads.

PowerPAD is a trademark of Texas Instruments.

IMPORTANT NOTICE AND DISCLAIMER

TI PROVIDES TECHNICAL AND RELIABILITY DATA (INCLUDING DATA SHEETS), DESIGN RESOURCES (INCLUDING REFERENCE DESIGNS), APPLICATION OR OTHER DESIGN ADVICE, WEB TOOLS, SAFETY INFORMATION, AND OTHER RESOURCES "AS IS" AND WITH ALL FAULTS, AND DISCLAIMS ALL WARRANTIES, EXPRESS AND IMPLIED, INCLUDING WITHOUT LIMITATION ANY IMPLIED WARRANTIES OF MERCHANTABILITY, FITNESS FOR A PARTICULAR PURPOSE OR NON-INFRINGEMENT OF THIRD PARTY INTELLECTUAL PROPERTY RIGHTS.

These resources are intended for skilled developers designing with TI products. You are solely responsible for (1) selecting the appropriate TI products for your application, (2) designing, validating and testing your application, and (3) ensuring your application meets applicable standards, and any other safety, security, regulatory or other requirements.

These resources are subject to change without notice. TI grants you permission to use these resources only for development of an application that uses the TI products described in the resource. Other reproduction and display of these resources is prohibited. No license is granted to any other TI intellectual property right or to any third party intellectual property right. TI disclaims responsibility for, and you will fully indemnify TI and its representatives against, any claims, damages, costs, losses, and liabilities arising out of your use of these resources.

TI's products are provided subject to [TI's Terms of Sale](#) or other applicable terms available either on [ti.com](https://www.ti.com) or provided in conjunction with such TI products. TI's provision of these resources does not expand or otherwise alter TI's applicable warranties or warranty disclaimers for TI products.

TI objects to and rejects any additional or different terms you may have proposed.

Mailing Address: Texas Instruments, Post Office Box 655303, Dallas, Texas 75265
Copyright © 2025, Texas Instruments Incorporated