

# CD74HC93, CD74HCT93 High-Speed CMOS Logic 4-Bit Binary Ripple Counter

## 1 Features

- Can be configured to divide by 2, 8, and 16
- Asynchronous reset
- Fanout (over temperature range)
  - Standard outputs: 10 LSTTL loads
  - Bus driver outputs: 15 LSTTL loads
- Wide operating temperature range:  $-55^{\circ}\text{C}$  to  $125^{\circ}\text{C}$
- Balances propagation delay and transition times
- Significant power reduction compared to LSTTL logic ICs
- HC types
  - 2 V to 6 V operation
  - High noise immunity:  $N_{IL} = 30\%$ ,  $N_{IH} = 30\%$  of  $V_{CC}$
- HCT types
  - 4.5 V to 5.5 V operation
  - Direct LSTTL input logic compatibility,  $V_{IL} = 0.8\text{ V}$  (max),  $V_{IH} = 2\text{ V}$  (min)
  - CMOS input compatibility,  $I_I \leq 1\ \mu\text{A}$  at  $V_{OL}$ ,  $V_{OH}$

## 2 Description

The CD74HC93 and CD74HCT93 are high-speed silicon-gate CMOS devices and are pin-compatible with low power Schottky TTL (LSTTL). These 4-bit binary ripple counters consist of four flip-flops internally connected to provide a divide-by-two section and a divide-by-eight section. Each section has a separate clock input ( $\overline{\text{CP}}0$  and  $\overline{\text{CP}}1$ ) to initiate state changes of the counter on the HIGH to LOW clock transition. State changes of the  $Q_n$  outputs do not occur simultaneously because of internal ripple delays. Therefore, decoded output signals are subject to decoding spikes and should not be used for clocks or strobes.

### Device Information

| PART NUMBER | PACKAGE <sup>(1)</sup> | BODY SIZE (NOM)    |
|-------------|------------------------|--------------------|
| CD74HC93M   | SOIC (14)              | 8.65 mm × 3.90 mm  |
| CD74HC93E   | PDIP (14)              | 19.31 mm × 6.35 mm |
| CD74HCT93E  | PDIP (14)              | 19.31 mm × 6.35 mm |

(1) For all available packages, see the orderable addendum at the end of the data sheet.

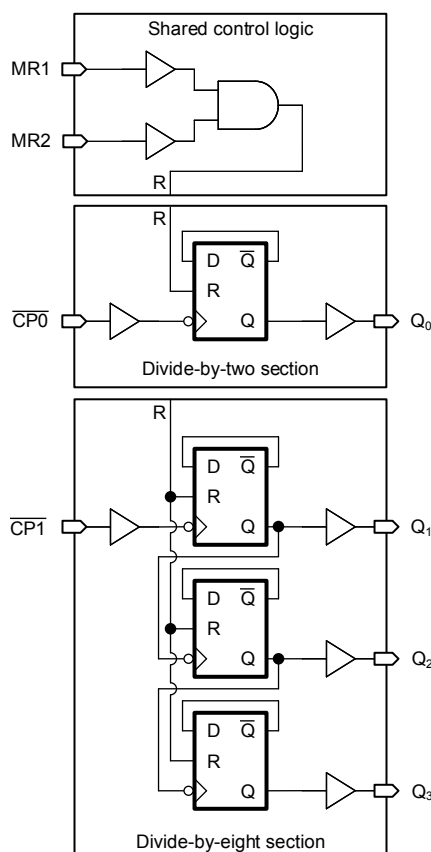

**Functional Block Diagram**



## Table of Contents

|  |   |  |    |
|--|---|--|----|
| <b>1 Features</b> .....                              | 1 | 7.2 Functional Block Diagram.....                                | 9  |
| <b>2 Description</b> .....                           | 1 | 7.3 Device Functional Modes.....                                 | 10 |
| <b>3 Revision History</b> .....                      | 2 | <b>8 Power Supply Recommendations</b> .....                      | 11 |
| <b>4 Pin Configuration and Functions</b> .....       | 3 | <b>9 Layout</b> .....  | 11 |
| <b>5 Specifications</b> .....                        | 4 | 9.1 Layout Guidelines.....                                       | 11 |
| 5.1 Absolute Maximum Ratings.....                    | 4 | <b>10 Device and Documentation Support</b> .....                 | 12 |
| 5.2 Recommended Operating Conditions.....            | 4 | 10.1 Documentation Support.....                                  | 12 |
| 5.3 Thermal Information.....                         | 4 | 10.2 Receiving Notification of Documentation Updates..           | 12 |
| 5.4 Electrical Characteristics.....                  | 5 | 10.3 Support Resources.....                                      | 12 |
| 5.5 Prerequisite for Switching Characteristics ..... | 6 | 10.4 Trademarks.....   | 12 |
| 5.6 Switching Characteristics .....                  | 6 | 10.5 Electrostatic Discharge Caution.....                        | 12 |
| <b>6 Parameter Measurement Information</b> .....     | 8 | 10.6 Glossary.....   | 12 |
| <b>7 Detailed Description</b> .....                  | 9 | <b>11 Mechanical, Packaging, and Orderable Information</b> ..... | 12 |
| 7.1 Overview.....                                    | 9 |  |    |

### 3 Revision History

NOTE: Page numbers for previous revisions may differ from page numbers in the current version.

| <b>Changes from Revision C (September 2003) to Revision D (March 2022)</b>   | <b>Page</b> |
|--|-------------|
| • Updated the numbering, formatting, tables, figures, and cross-references throughout the document to reflect modern data sheet standards..... | 1           |

## 4 Pin Configuration and Functions

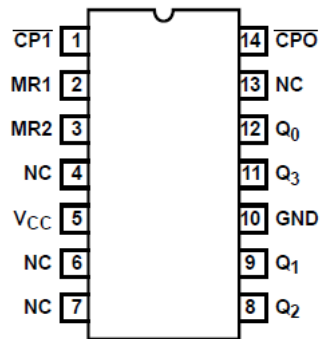

**N or D package  
14-Pin PDIP or SOIC  
Top View**

## 5 Specifications

### 5.1 Absolute Maximum Ratings

over operating free-air temperature range (unless otherwise noted)<sup>(1)</sup>

|                  |   | MIN   | MAX | UNIT |
|------------------|---|---|-----|------|
| V <sub>CC</sub>  | Supply voltage range                              | -0.5  | 7   | V    |
| I <sub>IK</sub>  | Input diode current <sup>(2)</sup>                | (V <sub>I</sub> < -0.5 V or V <sub>I</sub> > V <sub>CC</sub> + 0.5 V) | ±20 | mA   |
| I <sub>OK</sub>  | Output diode current <sup>(2)</sup>               | (V <sub>O</sub> < -0.5 V or V <sub>O</sub> > V <sub>CC</sub> + 0.5 V) | ±20 | mA   |
| I <sub>O</sub>   | Output source or sink current per output pin      | (V <sub>O</sub> > -0.5 V or V <sub>O</sub> < V <sub>CC</sub> + 0.5 V) | ±25 | mA   |
|                  | Continuous current through V <sub>CC</sub> or GND |   | ±50 | mA   |
| T <sub>J</sub>   | Junction temperature                              |   | 150 | °C   |
| T <sub>stg</sub> | Storage temperature                               | -65   | 150 | °C   |

- (1) Stresses beyond those listed under *absolute maximum ratings* may cause permanent damage to the device. These are stress ratings only and functional operation of the device at these or any other conditions beyond those indicated under *recommended operating conditions* is not implied. Exposure to absolute-maximum-rated conditions for extended periods may affect device reliability.
- (2) The input and output voltage ratings may be exceeded if the input and output current ratings are observed.

### 5.2 Recommended Operating Conditions

|                 |                                 | MIN       | NOM | MAX             | UNIT |
|-----------------|---------------------------------|-----------|-----|-----------------|------|
| V <sub>CC</sub> | Supply voltage                  | HC types  |     | 6               | V    |
|                 |                                 | HCT types | 4.5 | 5.5             |      |
| V <sub>I</sub>  | Input voltage                   | 0         |     | V <sub>CC</sub> | V    |
| V <sub>O</sub>  | Output voltage                  | 0         |     | V <sub>CC</sub> | V    |
| t <sub>t</sub>  | Input transition rise/fall time | 2 V       |     | 1000            | ns   |
|                 |                                 | 4.5 V     |     | 500             |      |
|                 |                                 | 6 V       |     | 400             |      |
| T <sub>A</sub>  | Operating free-air temperature  | -55       |     | 125             | °C   |

### 5.3 Thermal Information

| THERMAL METRIC   |   | D (SOIC) | N (PDIP) | UNIT |
|------------------|---|----------|----------|------|
|                  |   | 14 PINS  | 14 PINS  |      |
| R <sub>θJA</sub> | Junction-to-ambient thermal resistance <sup>(1)</sup> | 86       | 80       | °C/W |

- (1) For more information about traditional and new thermal metrics, see the [Semiconductor and IC package thermal metrics](#) application report.

## 5.4 Electrical Characteristics

| PARAMETER   |   | TEST CONDITIONS <sup>(1)</sup>                                    | V <sub>CC</sub><br>(V) | T <sub>A</sub> = 25°C |     |     | – 40°C to 85°C |     | – 55°C to 125°C |     | UNIT |
|---|---|---|------------------------|-----------------------|-----|-----|----------------|-----|-----------------|-----|------|
|   |   |   |                        | MIN                   | TYP | MAX | MIN            | MAX | MIN             | MAX |      |
| <b>HC TYPES</b>                                   |   |   |                        |                       |     |     |                |     |                 |     |      |
| V <sub>IH</sub>                                   | High level input voltage                |   | 2                      | 1.5                   |     |     | 1.5            |     | 1.5             |     | V    |
|   |   |   | 4.5                    | 3.15                  |     |     | 3.15           |     | 3.15            |     | V    |
|   |   |   | 6                      | 4.2                   |     |     | 4.2            |     | 4.2             |     | V    |
| V <sub>IL</sub>                                   | Low level input voltage                 |   | 2                      | 0.5                   |     |     | 0.5            |     | 0.5             |     | V    |
|   |   |   | 4.5                    | 1.35                  |     |     | 1.35           |     | 1.35            |     | V    |
|   |   |   | 6                      | 1.8                   |     |     | 1.8            |     | 1.8             |     | V    |
| V <sub>OH</sub>                                   | High-level output voltage               | I <sub>OH</sub> = – 20 μA   | 2                      | 1.9                   |     |     | 1.9            |     | 1.9             |     | V    |
|   |   | I <sub>OH</sub> = – 20 μA   | 4.5                    | 4.4                   |     |     | 4.4            |     | 4.4             |     | V    |
|   |   | I <sub>OH</sub> = – 20 μA   | 6                      | 5.9                   |     |     | 5.9            |     | 5.9             |     | V    |
|   |   | I <sub>OH</sub> = – 4 mA  | 4.5                    | 3.98                  |     |     | 3.84           |     | 3.7             |     | V    |
|   |   | I <sub>OH</sub> = – 5.2 mA  | 6                      | 5.48                  |     |     | 5.34           |     | 5.2             |     | V    |
| V <sub>OL</sub>                                   | Low-level output voltage                | I <sub>OL</sub> = 20 μA   | 2                      | 0.1                   |     |     | 0.1            |     | 0.1             |     | V    |
|   |   | I <sub>OL</sub> = 20 μA   | 4.5                    | 0.1                   |     |     | 10.1           |     | 0.1             |     | V    |
|   |   | I <sub>OL</sub> = 20 μA   | 6                      | 0.1                   |     |     | 0.1            |     | 0.1             |     | V    |
|   |   | I <sub>OL</sub> = 4 mA  | 4.5                    | 0.26                  |     |     | 0.33           |     | 0.4             |     | V    |
|   |   | I <sub>OL</sub> = 5.2 mA  | 6                      | 0.26                  |     |     | 0.33           |     | 0.4             |     | V    |
| I <sub>I</sub>                                    | Input leakage current                   | V <sub>CC</sub> or GND  | 6                      | ±0.1                  |     |     | ±1             |     | ±1              |     | nA   |
| I <sub>CC</sub>                                   | Supply current                          | V <sub>CC</sub> or GND  | 6                      | 8                     |     |     | 80             |     | 160             |     | μA   |
| I <sub>CC</sub>                                   | Supply-current change                   | One input at 0.5 V or 2.4 V, Other inputs at 0 or V <sub>CC</sub> | 5.5                    | 1.4 2.4               |     |     | 2.9            |     |                 |     | mA   |
| C <sub>i</sub>                                    | Input capacitance                       |   | 4.5 to 5.5             | 3 10                  |     |     | 10             |     |                 |     | pF   |
| <b>HCT TYPES</b>                                  |   |   |                        |                       |     |     |                |     |                 |     |      |
| V <sub>IH</sub>                                   | High level input voltage                |   | 4.5 to 5.5             | 2                     |     |     | 2              |     | 2               |     | V    |
| V <sub>IL</sub>                                   | Low level input voltage                 |   | 4.5 to 5.5             | 0.8                   |     |     | 0.8            |     | 0.8             |     | V    |
| V <sub>OH</sub>                                   | High level Output Voltage               | I <sub>OH</sub> = – 20 μA   | 4.5                    | 4.4                   |     |     | 4.4            |     | 4.4             |     | V    |
|   |   | I <sub>OH</sub> = – 4 mA  | 4.5                    | 3.98                  |     |     | 3.84           |     | 3.7             |     | V    |
| V <sub>OL</sub>                                   | Low level output voltage                | I <sub>OH</sub> = 20 μA   | 4.5                    | 0.1                   |     |     | 0.1            |     | 0.1             |     | V    |
|   |   | I <sub>OH</sub> = 4 mA  | 4.5                    | 0.26                  |     |     | 0.33           |     | 0.4             |     | V    |
| I <sub>I</sub>                                    | Input leakage current                   | V <sub>CC</sub> or GND  | 5.5                    | ±0.1                  |     |     | ±1             |     | ±1              |     | μA   |
| I <sub>CC</sub>                                   | Supply current                          | V <sub>CC</sub> or GND  | 5.5                    | 8                     |     |     | 80             |     | 160             |     | μA   |
| ΔI <sub>CC</sub> <sup>(2)</sup><br><sup>(3)</sup> | Additional supply current per input pin | $\overline{CP0}, \overline{CP1}$                                  | 4.5 to 5.5             | 100 216               |     |     | 270            |     | 294             |     | μA   |
|   |   | CLR1, CLR2  | 4.5 to 5.5             | 100 144               |     |     | 180            |     | 196             |     | μA   |

(1) V<sub>I</sub> = V<sub>IH</sub> or V<sub>IL</sub>, unless otherwise noted.

(2) For dual-supply systems theoretical worst case (V<sub>I</sub> = 2.4 V, V<sub>CC</sub> = 5.5 V) specifications is 1.8 mA.

(3) Inputs held at V<sub>CC</sub> – 2.1.

## 5.5 Prerequisite for Switching Characteristics

| PARAMETER        |   | V <sub>CC</sub> (V) | 25°C |     | – 40°C to 85°C |     | – 55°C to 125°C |     | UNIT |
|------------------|---|---------------------|------|-----|----------------|-----|-----------------|-----|------|
|                  |   |                     | MIN  | MAX | MIN            | MAX | MIN             | MAX |      |
| <b>HC TYPES</b>  |   |                     |      |     |                |     |                 |     |      |
| f <sub>MAX</sub> | Maximum clock frequency                               | 2                   | 6    |     | 5              |     | 4               |     | MHz  |
|                  |   | 4.5                 | 30   |     | 24             |     | 20              |     | MHz  |
|                  |   | 6                   | 35   |     | 28             |     | 24              |     | MHz  |
| t <sub>W</sub>   | Clock pulse width $\overline{CP0}$ , $\overline{CP1}$ | 2                   | 80   |     | 100            |     | 120             |     | ns   |
|                  |   | 4.5                 | 16   |     | 20             |     | 24              |     | ns   |
|                  |   | 6                   | 14   |     | 17             |     | 20              |     | ns   |
| t <sub>W</sub>   | Reset pulse width                                     | 2                   | 80   |     | 100            |     | 120             |     | ns   |
|                  |   | 4.5                 | 16   |     | 20             |     | 24              |     | ns   |
|                  |   | 6                   | 14   |     | 17             |     | 20              |     | ns   |
| t <sub>REM</sub> | Reset removal time                                    | 2                   | 50   |     | 65             |     | 75              |     | ns   |
|                  |   | 4.5                 | 10   |     | 13             |     | 15              |     | ns   |
|                  |   | 6                   | 9    |     | 11             |     | 13              |     | ns   |
| <b>HCT TYPES</b> |   |                     |      |     |                |     |                 |     |      |
| f <sub>MAX</sub> | Maximum clock frequency                               | 4.5                 | 30   |     | 24             |     | 20              |     | MHz  |
| t <sub>W</sub>   | Clock pulse width $\overline{CP0}$ , $\overline{CP1}$ | 4.5                 | 16   |     | 20             |     | 24              |     | ns   |
| t <sub>W</sub>   | Reset pulse width                                     | 4.5                 | 16   |     | 20             |     | 24              |     | ns   |
| t <sub>REM</sub> | Reset removal time                                    | 4.5                 | 10   |     | 13             |     | 15              |     | ns   |

## 5.6 Switching Characteristics

Input t<sub>r</sub>, t<sub>f</sub> = 6ns. C<sub>L</sub> = 50pF unless otherwise noted

| PARAMETER                           |                        | V <sub>CC</sub> (V) | 25°C |                   |     | – 40°C to 85°C |     | – 55°C to 125°C |     | UNIT |
|-------------------------------------|------------------------|---------------------|------|-------------------|-----|----------------|-----|-----------------|-----|------|
|                                     |                        |                     | MIN  | TYP               | MAX | MIN            | MAX | MIN             | MAX |      |
| <b>HC TYPES</b>                     |                        |                     |      |                   |     |                |     |                 |     |      |
| t <sub>PLH</sub> , t <sub>PHL</sub> | $\overline{CP0}$ to Q0 | 2                   |      |                   | 125 |                | 155 |                 | 190 | ns   |
|                                     |                        | 4.5                 |      | 10 <sup>(1)</sup> | 25  |                | 31  |                 | 38  | ns   |
|                                     |                        | 6                   |      |                   | 21  |                | 26  |                 | 32  | ns   |
| t <sub>PLH</sub> , t <sub>PHL</sub> | $\overline{CP1}$ to Q1 | 2                   |      |                   | 135 |                | 170 |                 | 205 | ns   |
|                                     |                        | 4.5                 |      |                   | 27  |                | 34  |                 | 41  | ns   |
|                                     |                        | 6                   |      |                   | 23  |                | 29  |                 | 35  | ns   |
| t <sub>PLH</sub> , t <sub>PHL</sub> | $\overline{CP1}$ to Q2 | 2                   |      |                   | 185 |                | 230 |                 | 280 | ns   |
|                                     |                        | 4.5                 |      |                   | 37  |                | 46  |                 | 56  | ns   |
|                                     |                        | 6                   |      |                   | 31  |                | 39  |                 | 48  | ns   |
| t <sub>PLH</sub> , t <sub>PHL</sub> | $\overline{CP1}$ to Q3 | 2                   |      |                   | 245 |                | 305 |                 | 370 | ns   |
|                                     |                        | 4.5                 |      | 21 <sup>(1)</sup> | 49  |                | 61  |                 | 74  | ns   |
|                                     |                        | 6                   |      |                   | 42  |                | 52  |                 | 63  | ns   |
| t <sub>PLH</sub> , t <sub>PHL</sub> | MR1, MR2 to Qn         | 2                   |      |                   | 155 |                | 195 |                 | 235 | ns   |
|                                     |                        | 4.5                 |      | 13 <sup>(1)</sup> | 31  |                | 39  |                 | 47  | ns   |
|                                     |                        | 6                   |      |                   | 26  |                | 33  |                 | 40  | ns   |
| t <sub>TLH</sub> , t <sub>THL</sub> | Output transition time | 2                   |      |                   | 75  |                | 95  |                 | 110 | ns   |
|                                     |                        | 4.5                 |      |                   | 15  |                | 19  |                 | 22  | ns   |
|                                     |                        | 6                   |      |                   | 13  |                | 16  |                 | 19  | ns   |
| C <sub>IN</sub>                     | Input capacitance      |                     |      |                   | 10  |                | 10  |                 | 10  | pF   |

## 5.6 Switching Characteristics (continued)

Input  $t_r$ ,  $t_f = 6\text{ns}$ .  $C_L = 50\text{pF}$  unless otherwise noted

| PARAMETER             |                               | $V_{CC}$ (V) | 25°C |                   |     | – 40°C to 85°C |     | – 55°C to 125°C |     | UNIT |
|-----------------------|-------------------------------|--------------|------|-------------------|-----|----------------|-----|-----------------|-----|------|
|                       |                               |              | MIN  | TYP               | MAX | MIN            | MAX | MIN             | MAX |      |
| $C_{PD}$              | Power dissipation capacitance |              | 25   |                   |     | 10             |     | 19              |     | pF   |
| <b>HCT TYPES</b>      |                               |              |      |                   |     |                |     |                 |     |      |
| $t_{PLH}$ , $t_{PHL}$ | $\overline{CP0}$ to Q0        | 4.5          |      | 14 <sup>(1)</sup> | 34  |                | 43  |                 | 51  | ns   |
| $t_{PLH}$ , $t_{PHL}$ | $\overline{CP1}$ to Q1        | 4.5          |      |                   | 34  |                | 43  |                 | 51  | ns   |
| $t_{PLH}$ , $t_{PHL}$ | $\overline{CP1}$ to Q2        | 4.5          |      |                   | 46  |                | 58  |                 | 69  | ns   |
| $t_{PLH}$ , $t_{PHL}$ | $\overline{CP1}$ to Q3        | 4.5          |      | 24 <sup>(1)</sup> | 58  |                | 73  |                 | 87  | ns   |
| $t_{PLH}$ , $t_{PHL}$ | MR1, MR2 to Qn                | 4.5          |      | 13 <sup>(1)</sup> | 33  |                | 41  |                 | 50  | ns   |
| $t_{TLH}$ , $t_{THL}$ | Output Transition time        | 4.5          |      |                   | 15  |                | 19  |                 | 22  | ns   |
| $C_{IN}$              | Input Capacitance             |              |      |                   | 10  |                | 10  |                 | 10  | pF   |
| $C_{PD}$              | Power dissipation capacitance |              |      | 25                |     |                |     |                 |     | pF   |

(1)  $C_L = 15\text{pF}$ .  $V_{CC} = 5$ .

## 6 Parameter Measurement Information

Phase relationships between waveforms were chosen arbitrarily. All input pulses are supplied by generators having the following characteristics:  $PRR \leq 1 \text{ MHz}$ ,  $Z_O = 50 \Omega$ ,  $t_f < 6 \text{ ns}$ .

For clock inputs,  $f_{max}$  is measured when the input duty cycle is 50%.

The outputs are measured one at a time with one input transition per measurement.

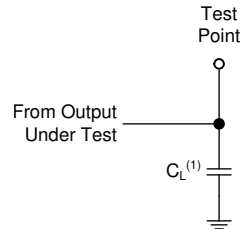

(1)  $C_L$  includes probe and test-fixture capacitance.

**Figure 6-1. Load Circuit for Push-Pull Outputs**

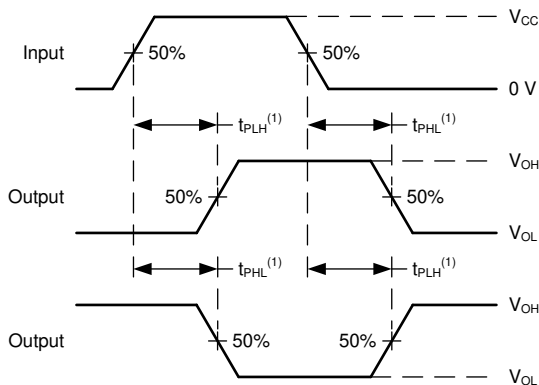

(1) The greater between  $t_{PLH}$  and  $t_{PHL}$  is the same as  $t_{pd}$ .

**Figure 6-2. Voltage Waveforms, Propagation Delays for Standard CMOS Inputs**

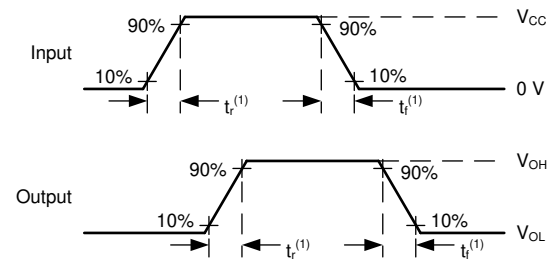

(1) The greater between  $t_r$  and  $t_f$  is the same as  $t_t$ .

**Figure 6-3. Voltage Waveforms, Input and Output Transition Times for Standard CMOS Inputs**

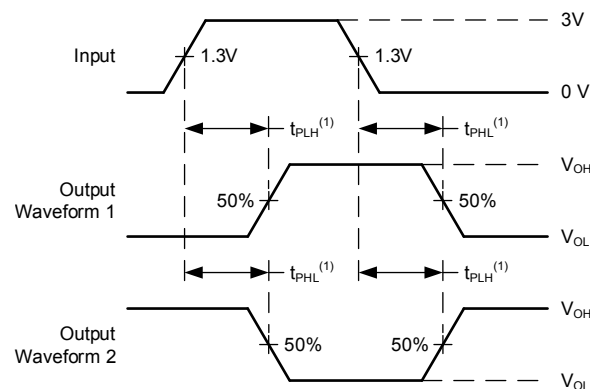

(1) The greater between  $t_{PLH}$  and  $t_{PHL}$  is the same as  $t_{pd}$ .

**Figure 6-4. Voltage Waveforms, Propagation Delays for TTL-Compatible Inputs**

## 7 Detailed Description

### 7.1 Overview

The CD74HC93 and CD74HCT93 are high-speed silicon-gate CMOS devices and are pin-compatible with low power Schottky TTL (LSTTL). These 4-bit binary ripple counters consist of four flip-flops internally connected to provide a divide-by-two section and a divide-by-eight section. Each section has a separate clock input ( $\overline{CP0}$  and  $\overline{CP1}$ ) to initiate state changes of the counter on the HIGH to LOW clock transition. State changes of the  $Q_n$  outputs do not occur simultaneously because of internal ripple delays. Therefore, decoded output signals are subject to decoding spikes and should not be used for clocks or strobes.

A gated AND asynchronous reset (MR1 and MR2) is provided which overrides both clocks and resets (clears) all flip-flops.

Because the output from the divide-by-two section is not internally connected to the succeeding stages, the device may be operated in various counting modes.

In a 4-bit ripple counter the output  $Q_0$  must be connected externally to input  $\overline{CP1}$ . The input count pulses are applied to clock input  $\overline{CP0}$ . Simultaneous frequency divisions of 2, 4, 8, and 16 are performed at the  $Q_0$ ,  $Q_1$ ,  $Q_2$ , and  $Q_3$  outputs as shown in the function table. As a 3-bit ripple counter the input count pulses are applied to input  $\overline{CP1}$ .

Simultaneous frequency divisions of 2, 4, and 8 are available at the  $Q_1$ ,  $Q_2$ ,  $Q_3$  outputs. Independent use of the first flipflop is available if the reset function coincides with the reset of the 3-bit ripple-through counter.

### 7.2 Functional Block Diagram

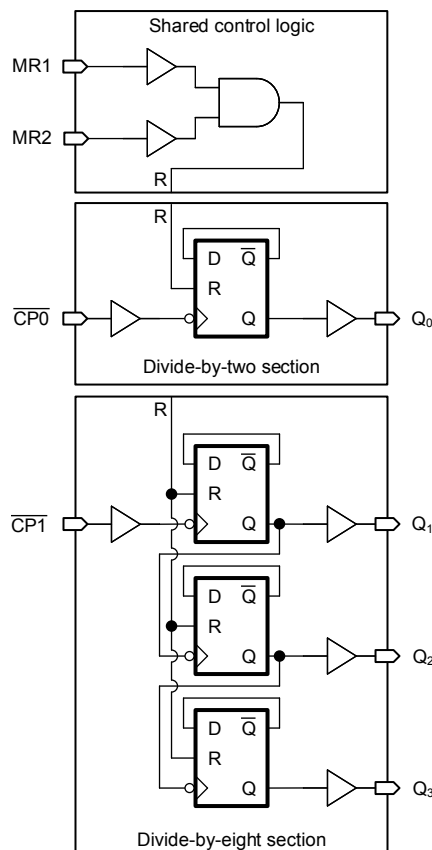

**Figure 7-1. Functional Block Diagram**

### 7.3 Device Functional Modes

**Truth Table**

| COUNT | OUTPUTS <sup>(1)</sup> |                |                |                |
|-------|------------------------|----------------|----------------|----------------|
|       | Q <sub>0</sub>         | Q <sub>1</sub> | Q <sub>2</sub> | Q <sub>3</sub> |
| 0     | L                      | L              | L              | L              |
| 1     | H                      | L              | L              | L              |
| 2     | L                      | H              | L              | L              |
| 3     | H                      | H              | L              | L              |
| 4     | L                      | L              | H              | L              |
| 5     | H                      | L              | H              | L              |
| 6     | L                      | H              | H              | L              |
| 7     | H                      | H              | H              | L              |
| 8     | L                      | L              | L              | H              |
| 9     | H                      | L              | L              | H              |
| 10    | L                      | H              | L              | H              |
| 11    | H                      | H              | L              | H              |
| 12    | L                      | L              | H              | H              |
| 13    | H                      | L              | H              | H              |
| 14    | L                      | H              | H              | H              |
| 15    | H                      | H              | H              | H              |

(1) H = High voltage level, L = Low voltage level.

**Table 7-1. Mode Selection**

| RESET OUTPUTS |     | OUTPUTS <sup>(1)</sup> |                |                |                |
|---------------|-----|------------------------|----------------|----------------|----------------|
| MR1           | MR2 | Q <sub>0</sub>         | Q <sub>1</sub> | Q <sub>2</sub> | Q <sub>3</sub> |
| H             | H   | L                      | L              | L              | L              |
| L             | H   | Count                  | Count          | Count          | Count          |
| H             | L   |                        |                |                |                |
| L             | L   |                        |                |                |                |

(1) H = High voltage level, L = Low voltage level.

## 8 Power Supply Recommendations

The power supply can be any voltage between the minimum and maximum supply voltage rating located in the *Recommended Operating Conditions*. Each  $V_{CC}$  terminal should have a good bypass capacitor to prevent power disturbance. A 0.1- $\mu\text{F}$  capacitor is recommended for this device. It is acceptable to parallel multiple bypass caps to reject different frequencies of noise. The 0.1- $\mu\text{F}$  and 1- $\mu\text{F}$  capacitors are commonly used in parallel. The bypass capacitor should be installed as close to the power terminal as possible for best results.

## 9 Layout

### 9.1 Layout Guidelines

When using multiple-input and multiple-channel logic devices inputs must not ever be left floating. In many cases, functions or parts of functions of digital logic devices are unused; for example, when only two inputs of a triple-input AND gate are used or only 3 of the 4 buffer gates are used. Such unused input pins must not be left unconnected because the undefined voltages at the outside connections result in undefined operational states. All unused inputs of digital logic devices must be connected to a logic high or logic low voltage, as defined by the input voltage specifications, to prevent them from floating. The logic level that must be applied to any particular unused input depends on the function of the device. Generally, the inputs are tied to GND or  $V_{CC}$ , whichever makes more sense for the logic function or is more convenient.

## 10 Device and Documentation Support

TI offers an extensive line of development tools. Tools and software to evaluate the performance of the device, generate code, and develop solutions are listed below.

### 10.1 Documentation Support

#### 10.1.1 Related Documentation

### 10.2 Receiving Notification of Documentation Updates

To receive notification of documentation updates, navigate to the device product folder on [ti.com](http://ti.com). Click on *Subscribe to updates* to register and receive a weekly digest of any product information that has changed. For change details, review the revision history included in any revised document.

### 10.3 Support Resources

TI E2E™ [support forums](#) are an engineer's go-to source for fast, verified answers and design help — straight from the experts. Search existing answers or ask your own question to get the quick design help you need.

Linked content is provided "AS IS" by the respective contributors. They do not constitute TI specifications and do not necessarily reflect TI's views; see TI's [Terms of Use](#).

### 10.4 Trademarks

TI E2E™ is a trademark of Texas Instruments.

All trademarks are the property of their respective owners.

### 10.5 Electrostatic Discharge Caution



This integrated circuit can be damaged by ESD. Texas Instruments recommends that all integrated circuits be handled with appropriate precautions. Failure to observe proper handling and installation procedures can cause damage.

ESD damage can range from subtle performance degradation to complete device failure. Precision integrated circuits may be more susceptible to damage because very small parametric changes could cause the device not to meet its published specifications.

### 10.6 Glossary

[TI Glossary](#) This glossary lists and explains terms, acronyms, and definitions.

## 11 Mechanical, Packaging, and Orderable Information

The following pages include mechanical, packaging, and orderable information. This information is the most current data available for the designated devices. This data is subject to change without notice and revision of this document. For browser-based versions of this data sheet, refer to the left-hand navigation.

**PACKAGING INFORMATION**

| Orderable part number       | Status<br>(1) | Material type<br>(2) | Package   Pins | Package qty   Carrier | RoHS<br>(3) | Lead finish/<br>Ball material<br>(4) | MSL rating/<br>Peak reflow<br>(5) | Op temp (°C) | Part marking<br>(6) |
|-----------------------------|---------------|----------------------|----------------|-----------------------|-------------|--------------------------------------|-----------------------------------|--------------|---------------------|
| <a href="#">CD74HC93E</a>   | Active        | Production           | PDIP (N)   14  | 25   TUBE             | Yes         | NIPDAU                               | N/A for Pkg Type                  | -55 to 125   | CD74HC93E           |
| CD74HC93E.A                 | Active        | Production           | PDIP (N)   14  | 25   TUBE             | Yes         | NIPDAU                               | N/A for Pkg Type                  | -55 to 125   | CD74HC93E           |
| CD74HC93EE4                 | Active        | Production           | PDIP (N)   14  | 25   TUBE             | Yes         | NIPDAU                               | N/A for Pkg Type                  | -55 to 125   | CD74HC93E           |
| <a href="#">CD74HC93M</a>   | Obsolete      | Production           | SOIC (D)   14  | -                     | -           | Call TI                              | Call TI                           | -55 to 125   | HC93M               |
| <a href="#">CD74HC93M96</a> | Active        | Production           | SOIC (D)   14  | 2500   LARGE T&R      | Yes         | NIPDAU   SN   NIPDAU                 | Level-1-260C-UNLIM                | -55 to 125   | HC93M               |
| CD74HC93M96.A               | Active        | Production           | SOIC (D)   14  | 2500   LARGE T&R      | Yes         | NIPDAU                               | Level-1-260C-UNLIM                | -55 to 125   | HC93M               |
| <a href="#">CD74HC93MT</a>  | Obsolete      | Production           | SOIC (D)   14  | -                     | -           | Call TI                              | Call TI                           | -55 to 125   | HC93M               |
| <a href="#">CD74HCT93E</a>  | Active        | Production           | PDIP (N)   14  | 25   TUBE             | Yes         | NIPDAU                               | N/A for Pkg Type                  | -55 to 125   | CD74HCT93E          |
| CD74HCT93E.A                | Active        | Production           | PDIP (N)   14  | 25   TUBE             | Yes         | NIPDAU                               | N/A for Pkg Type                  | -55 to 125   | CD74HCT93E          |

(1) **Status:** For more details on status, see our [product life cycle](#).

(2) **Material type:** When designated, preproduction parts are prototypes/experimental devices, and are not yet approved or released for full production. Testing and final process, including without limitation quality assurance, reliability performance testing, and/or process qualification, may not yet be complete, and this item is subject to further changes or possible discontinuation. If available for ordering, purchases will be subject to an additional waiver at checkout, and are intended for early internal evaluation purposes only. These items are sold without warranties of any kind.

(3) **RoHS values:** Yes, No, RoHS Exempt. See the [TI RoHS Statement](#) for additional information and value definition.

(4) **Lead finish/Ball material:** Parts may have multiple material finish options. Finish options are separated by a vertical ruled line. Lead finish/Ball material values may wrap to two lines if the finish value exceeds the maximum column width.

(5) **MSL rating/Peak reflow:** The moisture sensitivity level ratings and peak solder (reflow) temperatures. In the event that a part has multiple moisture sensitivity ratings, only the lowest level per JEDEC standards is shown. Refer to the shipping label for the actual reflow temperature that will be used to mount the part to the printed circuit board.

(6) **Part marking:** There may be an additional marking, which relates to the logo, the lot trace code information, or the environmental category of the part.

Multiple part markings will be inside parentheses. Only one part marking contained in parentheses and separated by a "-" will appear on a part. If a line is indented then it is a continuation of the previous line and the two combined represent the entire part marking for that device.

**Important Information and Disclaimer:**The information provided on this page represents TI's knowledge and belief as of the date that it is provided. TI bases its knowledge and belief on information provided by third parties, and makes no representation or warranty as to the accuracy of such information. Efforts are underway to better integrate information from third parties. TI has taken and continues to take reasonable steps to provide representative

and accurate information but may not have conducted destructive testing or chemical analysis on incoming materials and chemicals. TI and TI suppliers consider certain information to be proprietary, and thus CAS numbers and other limited information may not be available for release.

In no event shall TI's liability arising out of such information exceed the total purchase price of the TI part(s) at issue in this document sold by TI to Customer on an annual basis.

**TAPE AND REEL INFORMATION**

**QUADRANT ASSIGNMENTS FOR PIN 1 ORIENTATION IN TAPE**

\*All dimensions are nominal

| Device      | Package Type | Package Drawing | Pins | SPQ  | Reel Diameter (mm) | Reel Width W1 (mm) | A0 (mm) | B0 (mm) | K0 (mm) | P1 (mm) | W (mm) | Pin1 Quadrant |
|-------------|--------------|-----------------|------|------|--------------------|--------------------|---------|---------|---------|---------|--------|---------------|
| CD74HC93M96 | SOIC         | D               | 14   | 2500 | 330.0              | 16.4               | 6.5     | 9.0     | 2.1     | 8.0     | 16.0   | Q1            |
| CD74HC93M96 | SOIC         | D               | 14   | 2500 | 330.0              | 16.4               | 6.6     | 9.3     | 2.1     | 8.0     | 16.0   | Q1            |

**TAPE AND REEL BOX DIMENSIONS**



\*All dimensions are nominal

| Device      | Package Type | Package Drawing | Pins | SPQ  | Length (mm) | Width (mm) | Height (mm) |
|-------------|--------------|-----------------|------|------|-------------|------------|-------------|
| CD74HC93M96 | SOIC         | D               | 14   | 2500 | 356.0       | 356.0      | 35.0        |
| CD74HC93M96 | SOIC         | D               | 14   | 2500 | 366.0       | 364.0      | 50.0        |

**TUBE**

\*All dimensions are nominal

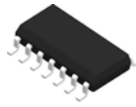
| Device       | Package Name | Package Type | Pins | SPQ | L (mm) | W (mm) | T (μm) | B (mm) |
|--------------|--------------|--------------|------|-----|--------|--------|--------|--------|
| CD74HC93E    | N            | PDIP         | 14   | 25  | 506    | 13.97  | 11230  | 4.32   |
| CD74HC93E    | N            | PDIP         | 14   | 25  | 506    | 13.97  | 11230  | 4.32   |
| CD74HC93E.A  | N            | PDIP         | 14   | 25  | 506    | 13.97  | 11230  | 4.32   |
| CD74HC93E.A  | N            | PDIP         | 14   | 25  | 506    | 13.97  | 11230  | 4.32   |
| CD74HC93EE4  | N            | PDIP         | 14   | 25  | 506    | 13.97  | 11230  | 4.32   |
| CD74HC93EE4  | N            | PDIP         | 14   | 25  | 506    | 13.97  | 11230  | 4.32   |
| CD74HCT93E   | N            | PDIP         | 14   | 25  | 506    | 13.97  | 11230  | 4.32   |
| CD74HCT93E   | N            | PDIP         | 14   | 25  | 506    | 13.97  | 11230  | 4.32   |
| CD74HCT93E.A | N            | PDIP         | 14   | 25  | 506    | 13.97  | 11230  | 4.32   |
| CD74HCT93E.A | N            | PDIP         | 14   | 25  | 506    | 13.97  | 11230  | 4.32   |



# D0014A

# PACKAGE OUTLINE

## SOIC - 1.75 mm max height

SMALL OUTLINE INTEGRATED CIRCUIT



4220718/A 09/2016

### NOTES:

1. All linear dimensions are in millimeters. Dimensions in parenthesis are for reference only. Dimensioning and tolerancing per ASME Y14.5M.
2. This drawing is subject to change without notice.
3. This dimension does not include mold flash, protrusions, or gate burrs. Mold flash, protrusions, or gate burrs shall not exceed 0.15 mm, per side.
4. This dimension does not include interlead flash. Interlead flash shall not exceed 0.43 mm, per side.
5. Reference JEDEC registration MS-012, variation AB.

# EXAMPLE BOARD LAYOUT

D0014A

SOIC - 1.75 mm max height

SMALL OUTLINE INTEGRATED CIRCUIT



LAND PATTERN EXAMPLE  
SCALE:8X



SOLDER MASK DETAILS

4220718/A 09/2016

NOTES: (continued)

- 6. Publication IPC-7351 may have alternate designs.
- 7. Solder mask tolerances between and around signal pads can vary based on board fabrication site.

# EXAMPLE STENCIL DESIGN

D0014A

SOIC - 1.75 mm max height

SMALL OUTLINE INTEGRATED CIRCUIT



SOLDER PASTE EXAMPLE  
BASED ON 0.125 mm THICK STENCIL  
SCALE:8X

4220718/A 09/2016

NOTES: (continued)

8. Laser cutting apertures with trapezoidal walls and rounded corners may offer better paste release. IPC-7525 may have alternate design recommendations.
9. Board assembly site may have different recommendations for stencil design.

N (R-PDIP-T\*\*)

PLASTIC DUAL-IN-LINE PACKAGE

16 PINS SHOWN



- NOTES:
- A. All linear dimensions are in inches (millimeters).
  - B. This drawing is subject to change without notice.
  - Falls within JEDEC MS-001, except 18 and 20 pin minimum body length (Dim A).
  - The 20 pin end lead shoulder width is a vendor option, either half or full width.

## IMPORTANT NOTICE AND DISCLAIMER

TI PROVIDES TECHNICAL AND RELIABILITY DATA (INCLUDING DATA SHEETS), DESIGN RESOURCES (INCLUDING REFERENCE DESIGNS), APPLICATION OR OTHER DESIGN ADVICE, WEB TOOLS, SAFETY INFORMATION, AND OTHER RESOURCES "AS IS" AND WITH ALL FAULTS, AND DISCLAIMS ALL WARRANTIES, EXPRESS AND IMPLIED, INCLUDING WITHOUT LIMITATION ANY IMPLIED WARRANTIES OF MERCHANTABILITY, FITNESS FOR A PARTICULAR PURPOSE OR NON-INFRINGEMENT OF THIRD PARTY INTELLECTUAL PROPERTY RIGHTS.

These resources are intended for skilled developers designing with TI products. You are solely responsible for (1) selecting the appropriate TI products for your application, (2) designing, validating and testing your application, and (3) ensuring your application meets applicable standards, and any other safety, security, regulatory or other requirements.

These resources are subject to change without notice. TI grants you permission to use these resources only for development of an application that uses the TI products described in the resource. Other reproduction and display of these resources is prohibited. No license is granted to any other TI intellectual property right or to any third party intellectual property right. TI disclaims responsibility for, and you will fully indemnify TI and its representatives against, any claims, damages, costs, losses, and liabilities arising out of your use of these resources.

TI's products are provided subject to [TI's Terms of Sale](#) or other applicable terms available either on [ti.com](https://www.ti.com) or provided in conjunction with such TI products. TI's provision of these resources does not expand or otherwise alter TI's applicable warranties or warranty disclaimers for TI products.

TI objects to and rejects any additional or different terms you may have proposed.

Mailing Address: Texas Instruments, Post Office Box 655303, Dallas, Texas 75265

Copyright © 2025, Texas Instruments Incorporated