

2.5-V INTEGRATED REFERENCE CIRCUIT

 Check for Samples: [LT1009M](#)

FEATURES

- Excellent Temperature Stability
 - Initial Tolerance: 0.2% Typical
 - Dynamic Impedance: 0.6 Ω Typical
 - Wide Operating Current Range
 - Directly Interchangeable With LM136
 - Needs No Adjustment for Minimum Temperature Coefficient
 - Available in Military ($-55^{\circ}\text{C}/125^{\circ}\text{C}$) Temperature Range ⁽¹⁾
- (1) Custom temperature ranges available

DESCRIPTION/ORDERING INFORMATION

The LT1009 reference circuit is a precision-trimmed 2.5-V shunt regulator featuring low dynamic impedance and a wide operating current range. The reference tolerance is achieved by on-chip trimming, which minimizes the initial voltage tolerance and the temperature coefficient, α_{VZ} .

Although the LT1009 needs no adjustments, a third terminal (ADJ) allows the reference voltage to be adjusted $\pm 5\%$ to eliminate system errors. In many applications, the LT1009 can be used as a terminal-for-terminal replacement for the LM136-2.5, which eliminates the external trim network.

The LT1009 uses include 5-V system references, 8-bit analog-to-digital converter (ADC) and digital-to-analog converter (DAC) references, and power-supply monitors. The device also can be used in applications such as digital voltmeters and current-loop measurement and control systems.

The LT1009 is characterized for operation from -55°C to 125°C .

Figure 1. SYMBOL

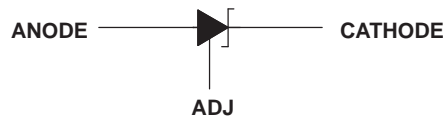

ORDERING INFORMATION⁽¹⁾

T_A	PACKAGE(BARE DIE) ⁽²⁾	ORDERABLE PART NUMBER
-55°C to 125°C	CHIPTRAY	LT1009MKGD1

(1) For the most current package and ordering information, see the Package Option Addendum at the end of this document, or see the TI web site at www.ti.com.

(2) Package drawings, thermal data, and symbolization are available at www.ti.com/packaging.

BARE DIE INFORMATION

DIE THICKNESS	BACKSIDE FINISH	BOND PAD METALIZATION COMPOSITION
15 Mils	Silicon with backgrind	AlCu/TiW



Please be aware that an important notice concerning availability, standard warranty, and use in critical applications of Texas Instruments semiconductor products and disclaimers thereto appears at the end of this data sheet.

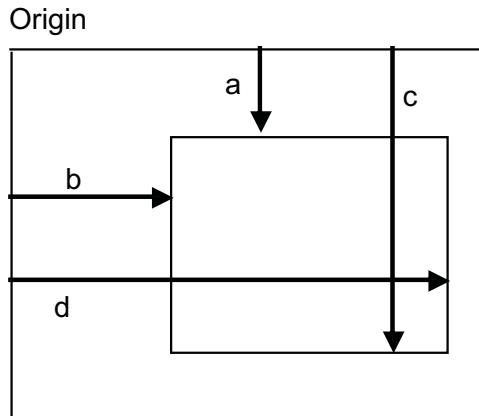

Table 1. Bond Pad Coordinates in Microns - Rev A

DISCRIPTION	PAD NUMBER	a	b	c	d
ANODE	1	127.000	127.000	243.840	243.840
ANODE	2	335.280	127.000	439.420	231.140
ADJ	3	716.280	130.810	833.120	243.840
Do not connect	4	1073.150	133.350	1169.670	229.870
Do not connect	5	1217.930	133.350	1314.450	229.870
Do not connect	6	1075.690	316.230	1172.210	412.750
Do not connect	7	1197.610	420.370	1294.130	516.890
Do not connect	8	1073.150	567.690	1169.670	664.210
Do not connect	9	1200.150	890.270	1296.670	986.790
Do not connect	10	1116.330	1032.510	1212.850	1129.030
CATHODE	11	902.970	929.640	1004.570	1066.800
CATHODE	12	703.580	1115.060	820.420	1229.360

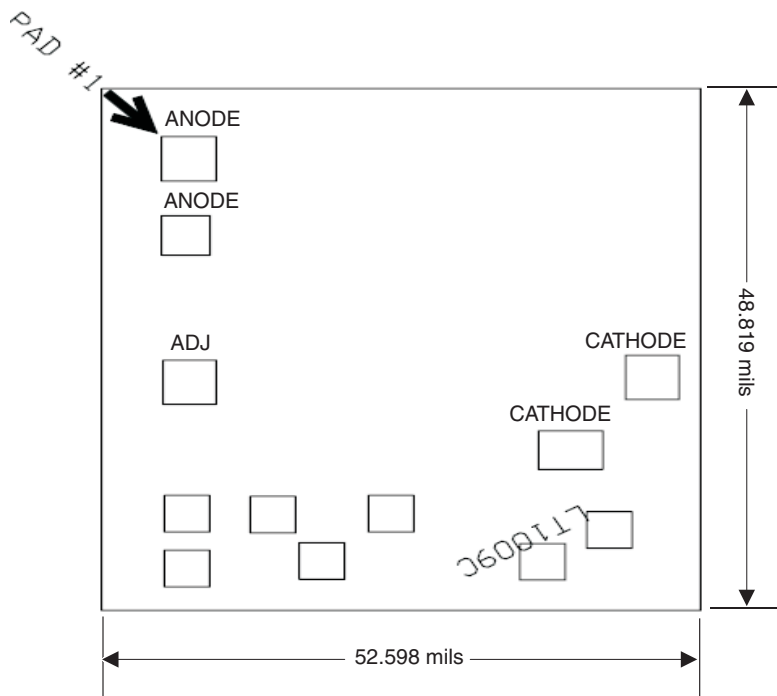
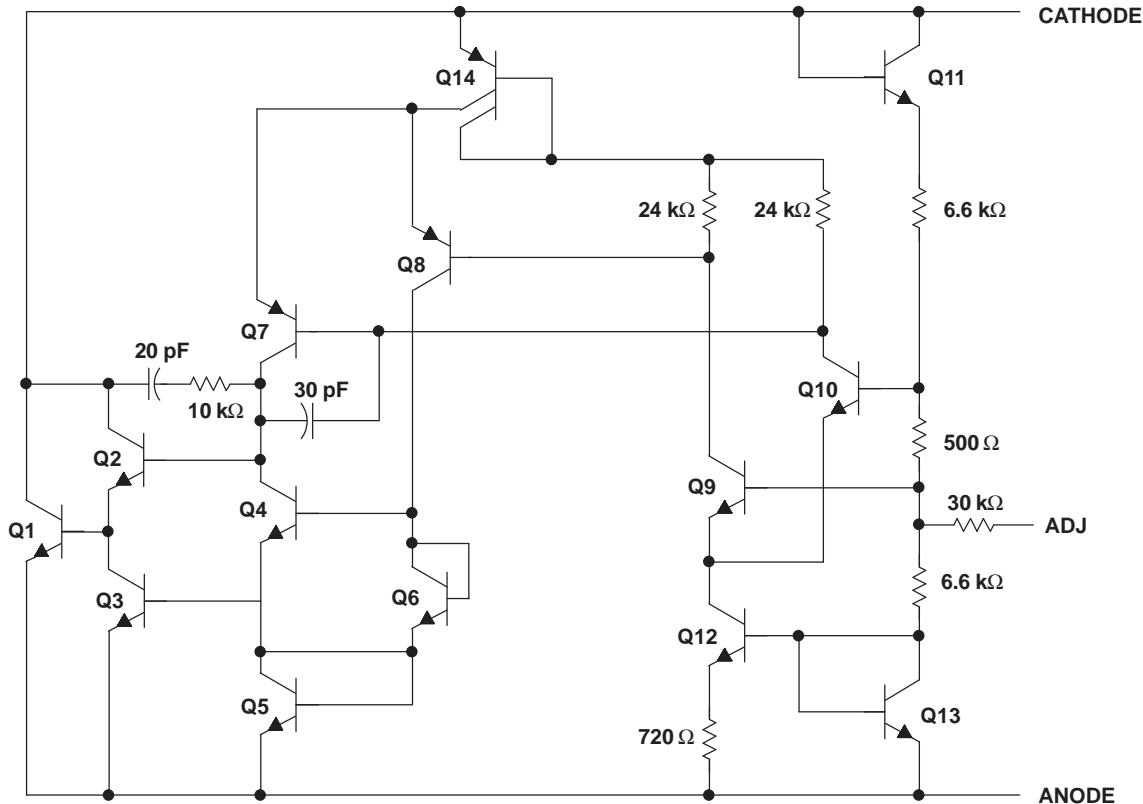

Figure 2. SCHEMATIC



NOTE: All component values shown are nominal.

ABSOLUTE MAXIMUM RATINGS⁽¹⁾

over operating free-air temperature range (unless otherwise noted)

		MIN	MAX	UNIT
I_R	Reverse current		20	mA
I_F	Forward current		10	mA
T_J	Operating virtual junction temperature ⁽²⁾		150	°C
T_{stg}	Storage temperature range	-65	150	°C

- (1) Stresses beyond those listed under "absolute maximum ratings" may cause permanent damage to the device. These are stress ratings only, and functional operation of the device at these or any other conditions beyond those indicated under "recommended operating conditions" is not implied. Exposure to absolute-maximum-rated conditions for extended periods may affect device reliability.
- (2) Maximum power dissipation is a function of $T_J(max)$, θ_{JA} , and T_A . The maximum allowable power dissipation at any allowable ambient temperature is $P_D = (T_J(max) - T_A)/\theta_{JA}$. Operating at the absolute maximum T_J of 150°C can affect reliability.

RECOMMENDED OPERATING CONDITIONS

		MIN	MAX	UNIT
T_A	Operating free-air temperature range	-55	125	°C

ELECTRICAL CHARACTERISTICS

at specified free-air temperature

PARAMETER	TEST CONDITIONS	T _A	LT1009M			UNIT	
			MIN	TYP	MAX		
V _Z	Reference voltage	I _Z = 1 mA	25°C	2.49	2.5	2.51	V
		Full range		2.46		2.535	
V _F	Forward voltage	I _F = 2 mA	25°C	0.4		1	V
Adjustment range		I _Z = 1 mA, V _{ADJ} = GND to V _Z	25°C	125			mV
		I _Z = 1 mA, V _{ADJ} = 0.6 V to V _Z – 0.6 V		45			
ΔV _{Z(temp)}	Change in reference voltage with temperature		Full range			15	mV
αV _Z	Average temperature coefficient of reference voltage ⁽¹⁾	I _Z = 1 mA, V _{ADJ} = open	Full range		20	35	ppm/ °C
ΔV _Z	Change in reference voltage with current	I _Z = 400 μA to 10 mA	25°C	6		10	mV
			Full range			12	
ΔV _Z /Δt	Long-term change in reference voltage	I _Z = 1 mA	25°C	20			ppm/ khr
Z _Z	Reference impedance	I _Z = 1 mA	25°C	0.6		1.6	Ω
			Full range			1.8	

- (1) The deviation parameter V_{Z(dev)} is defined as the difference between the maximum and minimum values obtained over the recommended operating temperature range, measured at I_Z = 1 mA. The average full-range temperature coefficient of the reference voltage (αV_Z) is defined as:

$$|\alpha V_Z| \left(\frac{\text{ppm}}{^\circ\text{C}} \right) = \frac{\left(\frac{V_{Z(\text{dev})}}{V_Z \text{ at } 25^\circ\text{C}} \right) \times 10^6}{\Delta T_A}$$

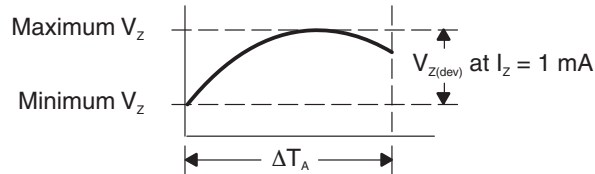

αV_Z can be positive or negative, depending upon whether the minimum V_Z or maximum V_Z, respectively, occurs at the lower temperature.

TYPICAL CHARACTERISTICS

Data at high and low temperatures are applicable only within the rated operating free-air temperature ranges of the various devices.

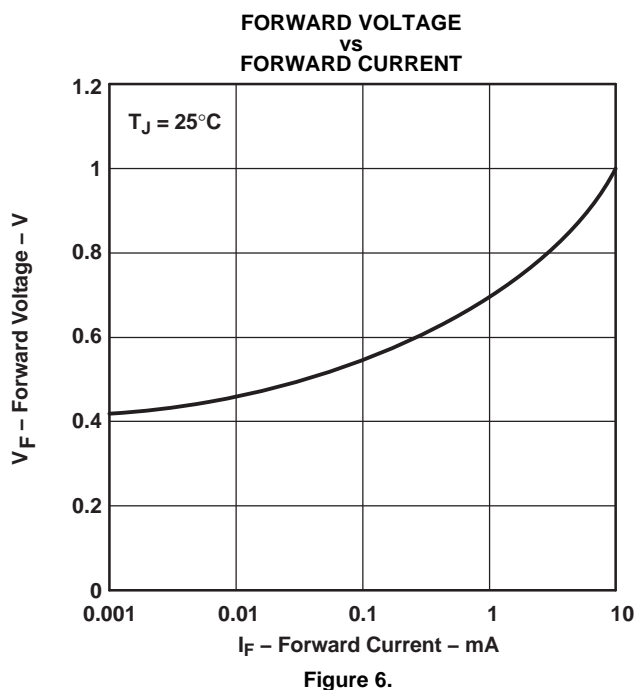
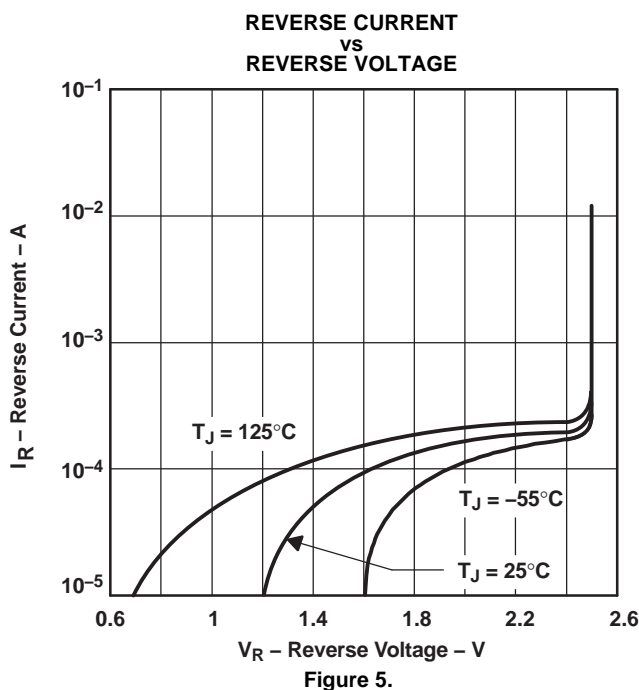
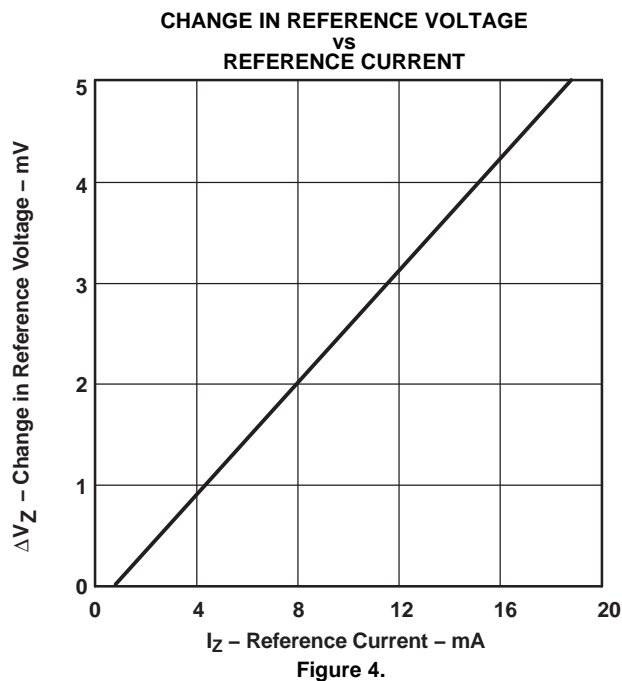
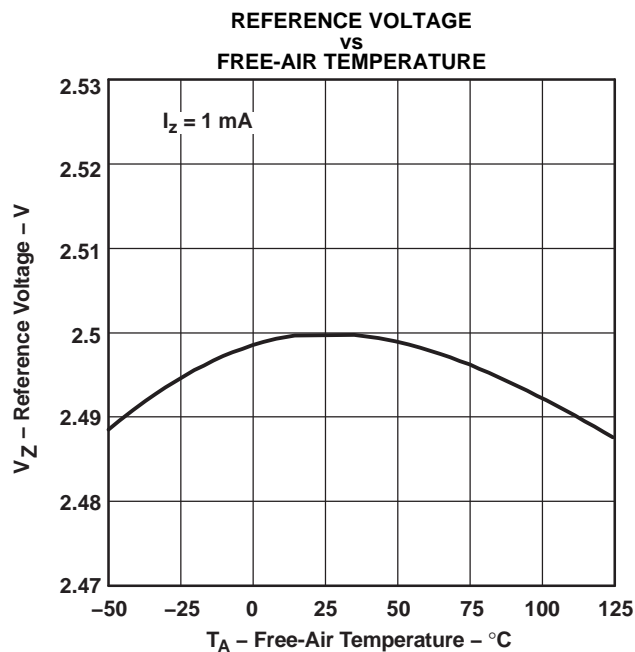

TYPICAL CHARACTERISTICS (continued)

REFERENCE IMPEDANCE
VS
FREQUENCY

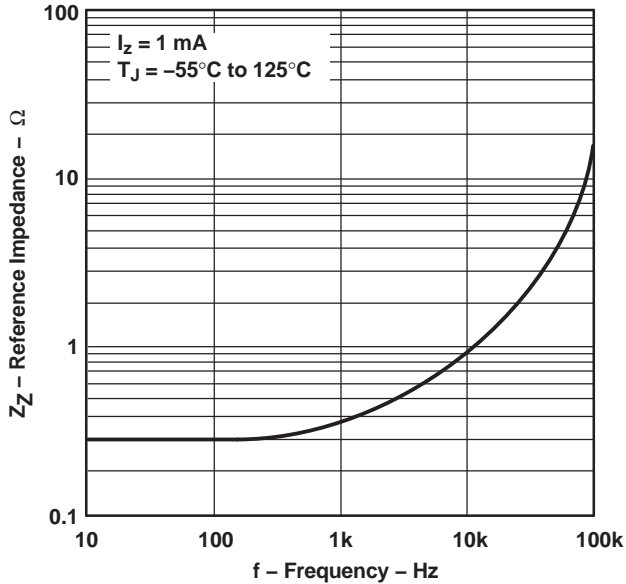

Figure 7.

NOISE VOLTAGE
VS
FREQUENCY

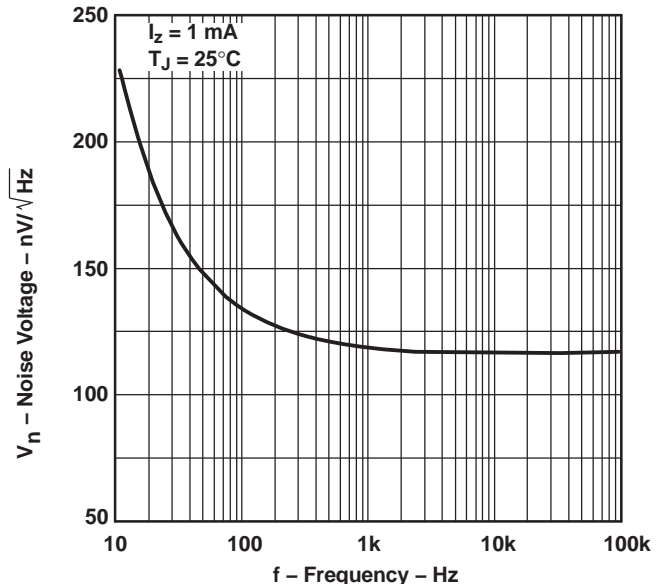

Figure 8.

TRANSIENT RESPONSE

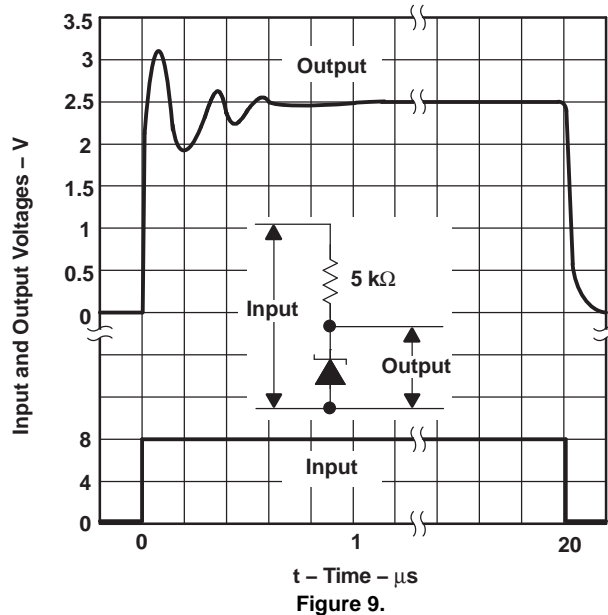
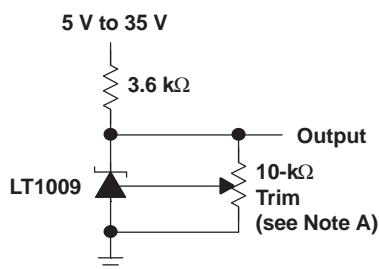

Figure 9.

APPLICATION INFORMATION



A. This does not affect temperature coefficient. It provides $\pm 5\%$ trim range.

Figure 10. 2.5-V Reference

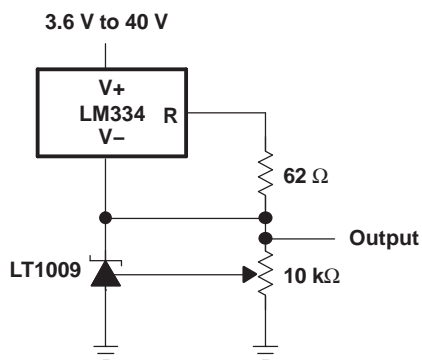

Figure 11. Adjustable Reference With Wide Supply Range

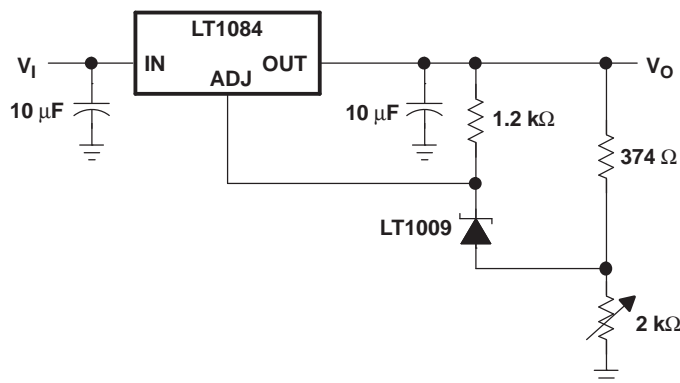

Figure 12. Power Regulator With Low Temperature Coefficient

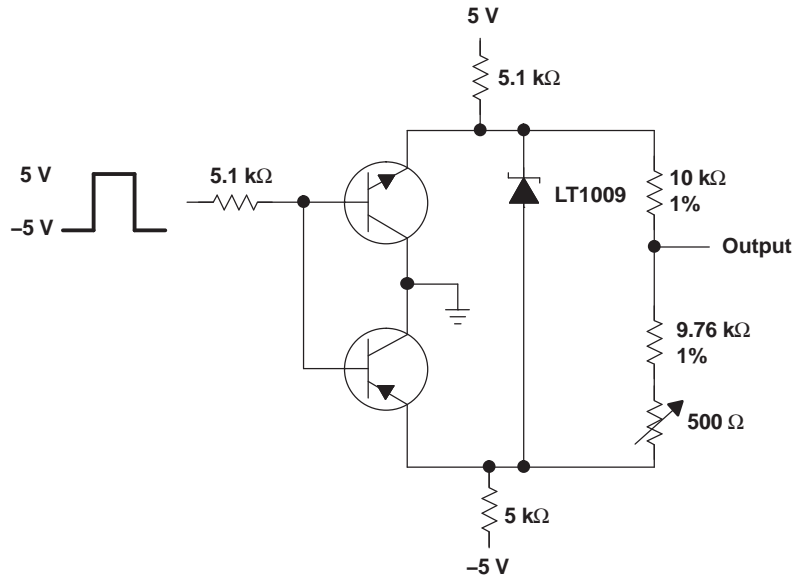

Figure 13. Switchable ± 1.25 -V Bipolar Reference

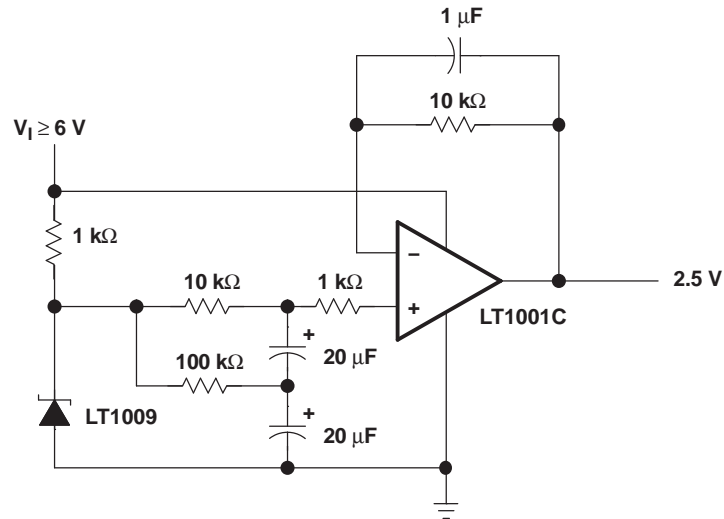

Figure 14. Low-Noise 2.5-V Buffered Reference

PACKAGING INFORMATION

Orderable part number	Status (1)	Material type (2)	Package Pins	Package qty Carrier	RoHS (3)	Lead finish/ Ball material (4)	MSL rating/ Peak reflow (5)	Op temp (°C)	Part marking (6)
LT1009MKGD1	Active	Production	XCEPT (KGD) 0	100 NOT REQUIRED	Yes	Call TI	N/A for Pkg Type	-55 to 125	
LT1009MKGD1.A	Active	Production	XCEPT (KGD) 0	100 NOT REQUIRED	Yes	Call TI	N/A for Pkg Type	-55 to 125	

(1) **Status:** For more details on status, see our [product life cycle](#).

(2) **Material type:** When designated, preproduction parts are prototypes/experimental devices, and are not yet approved or released for full production. Testing and final process, including without limitation quality assurance, reliability performance testing, and/or process qualification, may not yet be complete, and this item is subject to further changes or possible discontinuation. If available for ordering, purchases will be subject to an additional waiver at checkout, and are intended for early internal evaluation purposes only. These items are sold without warranties of any kind.

(3) **RoHS values:** Yes, No, RoHS Exempt. See the [TI RoHS Statement](#) for additional information and value definition.

(4) **Lead finish/Ball material:** Parts may have multiple material finish options. Finish options are separated by a vertical ruled line. Lead finish/Ball material values may wrap to two lines if the finish value exceeds the maximum column width.

(5) **MSL rating/Peak reflow:** The moisture sensitivity level ratings and peak solder (reflow) temperatures. In the event that a part has multiple moisture sensitivity ratings, only the lowest level per JEDEC standards is shown. Refer to the shipping label for the actual reflow temperature that will be used to mount the part to the printed circuit board.

(6) **Part marking:** There may be an additional marking, which relates to the logo, the lot trace code information, or the environmental category of the part.

Multiple part markings will be inside parentheses. Only one part marking contained in parentheses and separated by a "~" will appear on a part. If a line is indented then it is a continuation of the previous line and the two combined represent the entire part marking for that device.

Important Information and Disclaimer:The information provided on this page represents TI's knowledge and belief as of the date that it is provided. TI bases its knowledge and belief on information provided by third parties, and makes no representation or warranty as to the accuracy of such information. Efforts are underway to better integrate information from third parties. TI has taken and continues to take reasonable steps to provide representative and accurate information but may not have conducted destructive testing or chemical analysis on incoming materials and chemicals. TI and TI suppliers consider certain information to be proprietary, and thus CAS numbers and other limited information may not be available for release.

In no event shall TI's liability arising out of such information exceed the total purchase price of the TI part(s) at issue in this document sold by TI to Customer on an annual basis.

OTHER QUALIFIED VERSIONS OF LT1009M :

- Catalog : [LT1009](#)

NOTE: Qualified Version Definitions:

- Catalog - TI's standard catalog product

IMPORTANT NOTICE AND DISCLAIMER

TI PROVIDES TECHNICAL AND RELIABILITY DATA (INCLUDING DATA SHEETS), DESIGN RESOURCES (INCLUDING REFERENCE DESIGNS), APPLICATION OR OTHER DESIGN ADVICE, WEB TOOLS, SAFETY INFORMATION, AND OTHER RESOURCES "AS IS" AND WITH ALL FAULTS, AND DISCLAIMS ALL WARRANTIES, EXPRESS AND IMPLIED, INCLUDING WITHOUT LIMITATION ANY IMPLIED WARRANTIES OF MERCHANTABILITY, FITNESS FOR A PARTICULAR PURPOSE OR NON-INFRINGEMENT OF THIRD PARTY INTELLECTUAL PROPERTY RIGHTS.

These resources are intended for skilled developers designing with TI products. You are solely responsible for (1) selecting the appropriate TI products for your application, (2) designing, validating and testing your application, and (3) ensuring your application meets applicable standards, and any other safety, security, regulatory or other requirements.

These resources are subject to change without notice. TI grants you permission to use these resources only for development of an application that uses the TI products described in the resource. Other reproduction and display of these resources is prohibited. No license is granted to any other TI intellectual property right or to any third party intellectual property right. TI disclaims responsibility for, and you will fully indemnify TI and its representatives against, any claims, damages, costs, losses, and liabilities arising out of your use of these resources.

TI's products are provided subject to [TI's Terms of Sale](#) or other applicable terms available either on [ti.com](https://www.ti.com) or provided in conjunction with such TI products. TI's provision of these resources does not expand or otherwise alter TI's applicable warranties or warranty disclaimers for TI products.

TI objects to and rejects any additional or different terms you may have proposed.

Mailing Address: Texas Instruments, Post Office Box 655303, Dallas, Texas 75265

Copyright © 2025, Texas Instruments Incorporated