

## SNx4HCT574 Octal Edge-Triggered D-Type Flip-Flops With 3-State Outputs

### 1 Features

- Operating voltage range of 4.5V to 5.5V
- High-current 3-state noninverting outputs drive bus lines directly or up to 15 LSTTL loads
- Low power consumption, 80 $\mu$ A max  $I_{CC}$
- Typical  $t_{pd} = 22$ ns
- $\pm 6$ mA output drive at 5V
- Low input current of 1 $\mu$ A max
- Inputs are TTL-voltage compatible
- Bus-structured pinout

### 2 Description

These octal edge-triggered D-type flip-flops feature 3-state outputs designed specifically for bus driving. The 'HCT574 devices are particularly suitable for implementing buffer registers, I/O ports, bidirectional bus drivers, and working registers.

#### Device Information

PART NUMBER	PACKAGE <sup>(1)</sup>	PACKAGE SIZE <sup>(2)</sup>	BODY SIZE <sup>(3)</sup>
SN74HCT574	DGS (VSSOP, 20)	5.1mm x 4.9mm	5.1mm x 3mm
	DW (SOIC, 20)	12.80mm x 10.3mm	12.80mm x 7.50mm
	DB (SSOP, 20)	7.2mm x 7.8mm	7.2mm x 5.30mm
	PDIP (20)	24.33mm x 9.4mm	24.33mm x 6.35mm
	NS (SOP, 20)	12.6mm x 7.8mm	12.6mm x 5.3mm
	PW (TSSOP, 20)	6.50mm x 6.4mm	6.50mm x 4.40mm

- (1) For more information, see [Section 11](#).
- (2) The package size (length x width) is a nominal value and includes pins, where applicable.
- (3) The body size (length x width) is a nominal value and does not include pins.

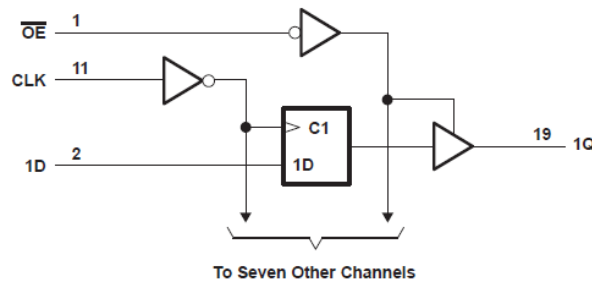

Logic Diagram (Positive Logic)



## Table of Contents

<b>1 Features</b> .....	1	6.2 Functional Block Diagram.....	8
<b>2 Description</b> .....	1	6.3 Device Functional Modes.....	8
<b>3 Pin Configuration and Functions</b> .....	3	<b>7 Application and Implementation</b> .....	9
<b>4 Specifications</b> .....	4	7.1 Power Supply Recommendations.....	9
4.1 Absolute Maximum Ratings .....	4	7.2 Layout.....	9
4.2 Recommended Operating Conditions .....	4	<b>8 Device and Documentation Support</b> .....	10
4.3 Thermal Information.....	4	8.1 Receiving Notification of Documentation Updates...	10
4.4 Electrical Characteristics.....	5	8.2 Support Resources.....	10
4.5 Timing Requirements.....	5	8.3 Trademarks.....	10
4.6 Switching Characteristics, C <sub>L</sub> = 50 pF .....	5	8.4 Electrostatic Discharge Caution.....	10
4.7 Switching Characteristics, C <sub>L</sub> = 150 pF.....	6	8.5 Glossary.....	10
4.8 Operating Characteristics.....	6	<b>9 Revision History</b> .....	10
<b>5 Parameter Measurement Information</b> .....	7	<b>10 Mechanical, Packaging, and Orderable Information</b> .....	10
<b>6 Detailed Description</b> .....	8		
6.1 Overview.....	8		

### 3 Pin Configuration and Functions

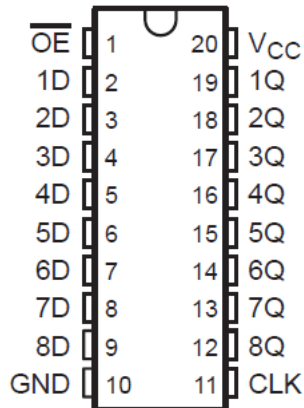

**DB, DGS, DW, N, NS, or PW package**  
**20-Pin SSOP, SOIC, PDIP, SO, TSSOP**  
**Top View**

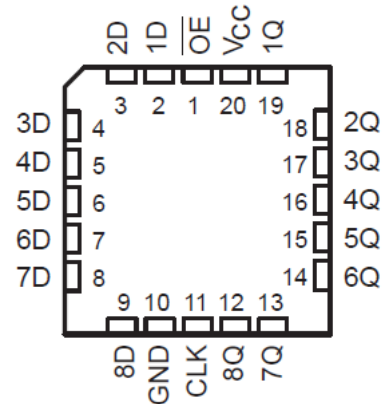

**FK Package**  
**20-Pin LCCC**  
**Top View**

**Table 3-1. Pin Functions**

NAME <sup>(1)</sup>	PIN	TYPE	DESCRIPTION
1OE	1	I	Output enable 1
1A1	2	I	1A1 input
2Y4	3	O	2Y4 output
1A2	4	I	1A2 input
2Y3	5	O	2Y3 output
1A3	6	I	1A3 input
2Y2	7	O	2Y2 output
1A4	8	I	1A4 input
2Y1	9	O	2Y1 output
GND	10	—	Ground pin
2A1	11	I	2A1 input
1Y4	12	O	1Y4 output
2A2	13	I	2A2 input
1Y3	14	O	1Y3 output
2A3	15	I	2A3 input
1Y2	16	O	1Y2 output
2A4	17	I	2A4 input
1Y1	18	O	1Y1 output
2OE	19	I	Output enable 2
VCC	20	—	Power pin

(1) I = input, O = output, P = power, FB = feedback, GND = ground, N/A = not applicable

## 4 Specifications

### 4.1 Absolute Maximum Ratings

over operating free-air temperature range (unless otherwise noted)<sup>(1)</sup>

		MIN	MAX	UNIT
V <sub>CC</sub>	Supply voltage range	-0.5	7	V
I <sub>IK</sub>	Input clamp current <sup>(2)</sup>	V <sub>I</sub> < 0 or V <sub>I</sub> > V <sub>CC</sub>		±20 mA
I <sub>OK</sub>	Output clamp current <sup>(2)</sup>	V <sub>O</sub> < 0 or V <sub>O</sub> > V <sub>CC</sub>		±20 mA
I <sub>O</sub>	Continuous output current	V <sub>O</sub> = 0 to V <sub>CC</sub>		±35 mA
	Continuous current through V <sub>CC</sub> or GND			±70 mA
T <sub>J</sub>	Junction temperature			150 °C
T <sub>stg</sub>	Storage temperature range	-65	150	°C

- (1) Stresses beyond those listed under “absolute maximum ratings” may cause permanent damage to the device. These are stress ratings only, and functional operation of the device at these or any other conditions beyond those indicated under “recommended” operating conditions” is not implied. Exposure to absolute-maximum-rated conditions for extended periods may affect device reliability.
- (2) The input and output voltage ratings may be exceeded if the input and output current ratings are observed.

### 4.2 Recommended Operating Conditions

over operating free-air temperature range (unless otherwise noted)<sup>(1)</sup>

		SN54HCT574			SN74HCT574			UNIT
		MIN	NOM	MAX	MIN	NOM	MAX	
V <sub>CC</sub>	Supply voltage	4.5	5	5.5	4.5	5	5.5	V
V <sub>IH</sub>	High-level input voltage	V <sub>CC</sub> = 4.5 V to 5.5 V		2	2			V
V <sub>IL</sub>	Low-level input voltage	V <sub>CC</sub> = 4.5 V to 5.5 V			0.8		0.8	V
V <sub>I</sub>	Input voltage	0	V <sub>CC</sub>		0	V <sub>CC</sub>		V
V <sub>O</sub>	Output voltage	0	V <sub>CC</sub>		0	V <sub>CC</sub>		V
Δt/Δv	Input transition rise/fall time			500	500			ns
T <sub>A</sub>	Operating free-air temperature	-55	125		-40	85		°C

- (1) All unused inputs of the device must be held at V<sub>CC</sub> or GND to ensure proper device operation. Refer to the TI application report, *Implications of Slow or Floating CMOS Inputs*, literature number [SCBA004](#).

### 4.3 Thermal Information

THERMAL METRIC		DGS (VSSOP)	DW (SOIC)	DB (SSOP)	N (PDIP)	NS (SO)	PW (TSSOP)	UNIT
		20 PINS	20 PINS	20 PINS	20 PINS	20 PINS	20 PINS	
R <sub>θJA</sub>	Junction-to-ambient thermal resistance <sup>(1)</sup>	130.6	109.1	122.7	84.6	113.4	131.8	°C/W
R <sub>θJC(top)</sub>	Junction-to-case (top) thermal resistance	68.7	76	81.6	72.5	78.6	72.2	°C/W
R <sub>θJB</sub>	Junction-to-board thermal resistance	85.4	77.6	77.5	65.3	78.4	82.8	°C/W
Ψ <sub>JT</sub>	Junction-to-top characterization parameter	10.5	51.5	46.1	55.3	47.1	21.5	°C/W
Ψ <sub>JB</sub>	Junction-to-board characterization parameter	85.0	77.1	77.1	65.2	78.1	82.4	°C/W
R <sub>θJC(bot)</sub>	Junction-to-case (bottom) thermal resistance	N/A	N/A	N/A	N/A	N/A	N/A	°C/W

- (1) For more information about traditional and new thermal metrics, see the [Semiconductor and IC package thermal metrics](#) application report.

## 4.4 Electrical Characteristics

over recommended operating free-air temperature range (unless otherwise noted)

PARAMETER	TEST CONDITIONS		V <sub>CC</sub>	T <sub>A</sub> = 25°C			SN54HCT574		SN74HCT574		UNIT
				MIN	TYP	MAX	MIN	MAX	MIN	MAX	
V <sub>OH</sub>	V <sub>I</sub> = V <sub>IH</sub> or V <sub>IL</sub>	I <sub>OH</sub> = -20 μA	4.5 V	4.4	4.499		4.4		4.4	V	
		I <sub>OH</sub> = -6 mA		3.98	4.3		3.7	3.84			
V <sub>OL</sub>	V <sub>I</sub> = V <sub>IH</sub> or V <sub>IL</sub>	I <sub>OL</sub> = 20 μA	4.5 V		0.001	0.1		0.1	0.1	V	
		I <sub>OL</sub> = 6 mA			0.17	0.26		0.4	0.33		
I <sub>I</sub>	V <sub>I</sub> = V <sub>CC</sub> or 0		5.5 V		±0.1	±100		±1000	±1000	nA	
I <sub>OZ</sub>	V <sub>O</sub> = V <sub>CC</sub> or 0		5.5 V		±0.01	±0.5		±10	±5	μA	
I <sub>CC</sub>	V <sub>I</sub> = V <sub>CC</sub> or 0, I <sub>O</sub> = 0		5.5 V			8		160	80	μA	
ΔI <sub>CC</sub> <sup>(1)</sup>	One input at 0.5 V or 2.4 V, Other inputs at 0 or V <sub>CC</sub>		5.5 V		1.4	2.4		3	2.9	mA	
C <sub>i</sub>			4.5 V to 5.5 V		3	10		10	10	pF	

(1) This is the increase in supply current for each input that is at one of the specified TTL voltage levels rather than 0 V or V<sub>CC</sub>.

## 4.5 Timing Requirements

over recommended operating free-air temperature range (unless otherwise noted)

		V <sub>CC</sub>	T <sub>A</sub> = 25°C		SN54HCT574		SN74HCT574		UNIT
			MIN	MAX	MIN	MAX	MIN	MAX	
f <sub>clock</sub>	Clock frequency	4.5 V		30		20		24	MHz
		5.5 V		33		22		27	
t <sub>w</sub>	Pulse duration, CLK high or low	4.5 V		16		24		20	ns
		5.5 V		14		22		18	
t <sub>su</sub>	Setup time, data before CLK↑	4.5 V		20		30		25	ns
		5.5 V		17		27		23	
t <sub>h</sub>	Hold time, data after CLK↑	4.5 V		5		5		5	ns
		5.5 V		5		5		5	

## 4.6 Switching Characteristics, C<sub>L</sub> = 50 pF

over recommended operating free-air temperature range, C<sub>L</sub> = 50 pF (unless otherwise noted) (see [Load Circuit and Voltage Waveforms](#))

PARAMETER	FROM (INPUT)	TO (OUTPUT)	V <sub>CC</sub>	T <sub>A</sub> = 25°C			SN54HCT574		SN74HCT574		UNIT
				MIN	TYP	MAX	MIN	MAX	MIN	MAX	
f <sub>max</sub>			4.5 V	30	36		20		24	MHz	
			5.5 V	33	40		22		27		
t <sub>pd</sub>	CLK	Any Q	4.5 V		30	36		54		45	ns
			5.5 V		25	32		48		41	
t <sub>en</sub>	OE	Any Q	4.5 V		26	30		45		38	ns
			5.5 V		23	27		41		34	
t <sub>dis</sub>	OE	Any Q	4.5 V		23	30		45		38	ns
			5.5 V		22	27		41		34	
t <sub>t</sub>		Any Q	4.5 V		10	12		18		15	ns
			5.5 V		9	11		16		14	

#### 4.7 Switching Characteristics, $C_L = 150$ pF

over recommended operating free-air temperature range,  $C_L = 150$  pF (unless otherwise noted) (see [Load Circuit and Voltage Waveforms](#))

PARAMETER	FROM (INPUT)	TO (OUTPUT)	$V_{CC}$	$T_A = 25^\circ\text{C}$			SN54HCT574		SN74HCT574		UNIT
				MIN	TYP	MAX	MIN	MAX	MIN	MAX	
$f_{max}$			4.5 V	30	36		20		24	MHz	
			5.5 V	33	40		22		27		
$t_{pd}$	CLK	Any Q	4.5 V		40	53		80		66	ns
			5.5 V		35	47		71		60	
$t_{en}$	$\overline{OE}$	Any Q	4.5 V		34	47		71		59	ns
			5.5 V		29	39		94		78	
$t_t$		Any Q	4.5 V		18	42		63		53	ns
			5.5 V		16	38		57		48	

#### 4.8 Operating Characteristics

$T_A = 25^\circ\text{C}$

PARAMETER		TEST CONDITIONS	TYP	UNIT
$C_{pd}$	Power dissipation capacitance per flip-flop	No load	93	pF

## 5 Parameter Measurement Information

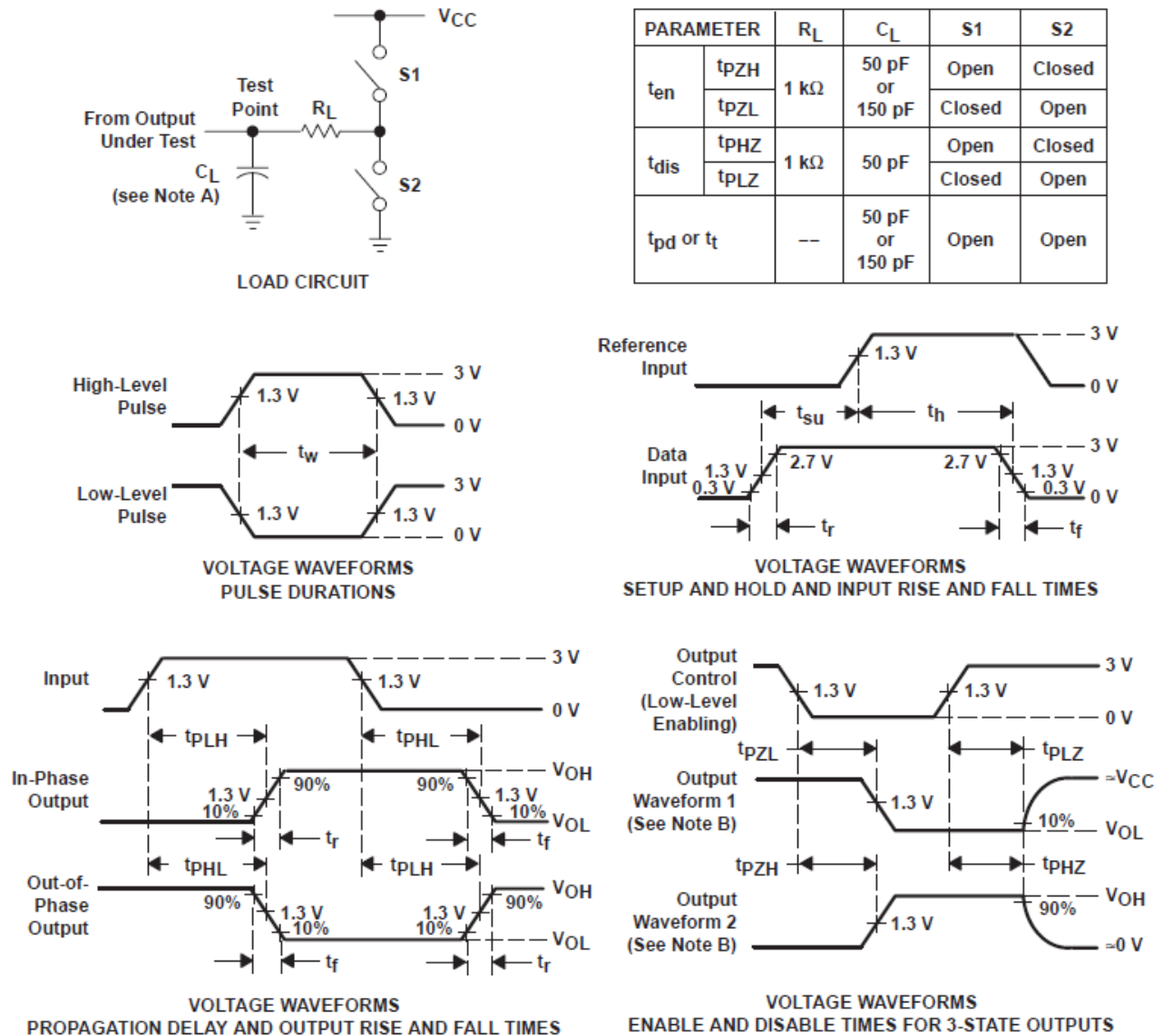

- $C_L$  includes probe and test-fixture capacitance.
- Waveform 1 is for an output with internal conditions such that the output is low except when disabled by the output control. Waveform 2 is for an output with internal conditions such that the output is high except when disabled by the output control.
- Phase relationships between waveforms were chosen arbitrarily. All input pulses are supplied by generators having the following characteristics:  $PRR \leq 1$  MHz,  $Z_O = 50 \Omega$ ,  $t_r = 6$  ns,  $t_f = 6$  ns.
- For clock inputs,  $f_{max}$  measured when the input duty cycle is 50%.
- The outputs are measured one at a time with one input transition per measurement.
- $t_{PLZ}$  and  $t_{PHZ}$  are the same as  $t_{dis}$ .
- $t_{PZL}$  and  $t_{PZH}$  are the same as  $t_{en}$ .
- $t_{PLH}$  and  $t_{PHL}$  are the same as  $t_{pd}$ .

Figure 5-1. Load Circuit and Voltage Waveforms

## 6 Detailed Description

### 6.1 Overview

These octal edge-triggered D-type flip-flops feature 3-state outputs designed specifically for bus driving. The 'HCT574 devices are particularly suitable for implementing buffer registers, I/O ports, bidirectional bus drivers, and working registers.

The eight flip-flops enter data on the low-to-high transition of the clock (CLK) input.

A buffered output-enable ( $\overline{OE}$ ) input can be used to place the eight outputs in either a normal logic state (high or low logic levels) or the high-impedance state. In the high-impedance state, the outputs neither load nor drive the bus lines significantly. The high-impedance state and increased drive provide the capability to drive bus lines without interface or pullup components.

$\overline{OE}$  does not affect the internal operations of the flip-flops. Old data can be retained or new data can be entered while the outputs are in the high-impedance state.

### 6.2 Functional Block Diagram

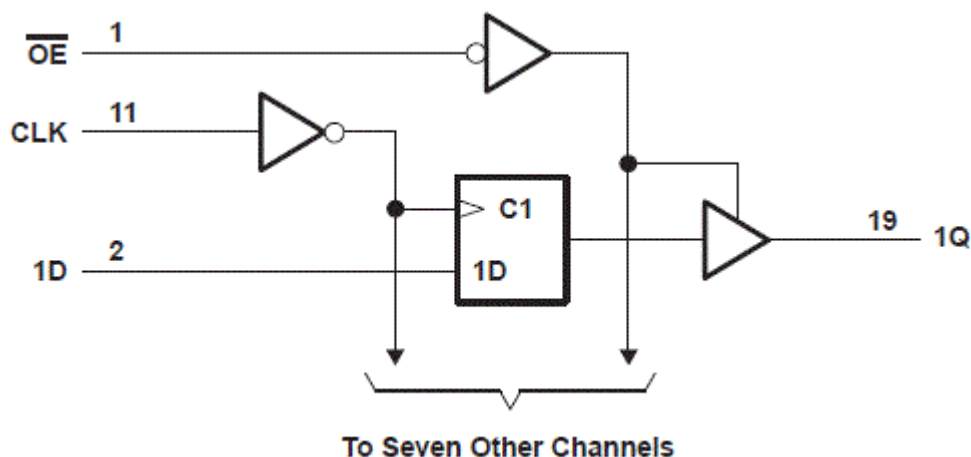

### 6.3 Device Functional Modes

**Table 6-1. Function Table  
(Each Flip-Flop)**

INPUTS			OUTPUT
$\overline{OE}$	CLK	D	Q
L	↑	H	H
L	↑	L	L
L	H or L	X	$Q_0$
H	X	X	Z

## 7 Application and Implementation

---

### Note

Information in the following applications sections is not part of the TI component specification, and TI does not warrant its accuracy or completeness. TI's customers are responsible for determining suitability of components for their purposes, as well as validating and testing their design implementation to confirm system functionality.

---

### 7.1 Power Supply Recommendations

The power supply can be any voltage between the minimum and maximum supply voltage rating located in the *Recommended Operating Conditions*. Each  $V_{CC}$  terminal should have a good bypass capacitor to prevent power disturbance. A 0.1 $\mu$ F capacitor is recommended for this device. It is acceptable to parallel multiple bypass capacitors to reject different frequencies of noise. The 0.1 $\mu$ F and 1 $\mu$ F capacitors are commonly used in parallel. The bypass capacitor should be installed as close to the power terminal as possible for best results.

### 7.2 Layout

#### 7.2.1 Layout Guidelines

When using multiple-input and multiple-channel logic devices, inputs must never be left floating. In many cases, functions or parts of functions of digital logic devices are unused; for example, when only two inputs of a triple-input AND gate are used or only 3 of the 4 buffer gates are used. Such unused input pins must not be left unconnected because the undefined voltages at the outside connections result in undefined operational states. All unused inputs of digital logic devices must be connected to a logic high or logic low voltage, as defined by the input voltage specifications, to prevent them from floating. The logic level that must be applied to any particular unused input depends on the function of the device. Generally, the inputs are tied to GND or  $V_{CC}$ , whichever makes more sense for the logic function or is more convenient.

## 8 Device and Documentation Support

TI offers an extensive line of development tools. Tools and software to evaluate the performance of the device, generate code, and develop solutions are listed below.

### 8.1 Receiving Notification of Documentation Updates

To receive notification of documentation updates, navigate to the device product folder on [ti.com](http://ti.com). Click on *Notifications* to register and receive a weekly digest of any product information that has changed. For change details, review the revision history included in any revised document.

### 8.2 Support Resources

TI E2E™ [support forums](#) are an engineer's go-to source for fast, verified answers and design help — straight from the experts. Search existing answers or ask your own question to get the quick design help you need.

Linked content is provided "AS IS" by the respective contributors. They do not constitute TI specifications and do not necessarily reflect TI's views; see TI's [Terms of Use](#).

### 8.3 Trademarks

TI E2E™ is a trademark of Texas Instruments.

All trademarks are the property of their respective owners.

### 8.4 Electrostatic Discharge Caution



This integrated circuit can be damaged by ESD. Texas Instruments recommends that all integrated circuits be handled with appropriate precautions. Failure to observe proper handling and installation procedures can cause damage.

ESD damage can range from subtle performance degradation to complete device failure. Precision integrated circuits may be more susceptible to damage because very small parametric changes could cause the device not to meet its published specifications.

### 8.5 Glossary

[TI Glossary](#) This glossary lists and explains terms, acronyms, and definitions.

## 9 Revision History

NOTE: Page numbers for previous revisions may differ from page numbers in the current version.

Changes from Revision G (July 2022) to Revision H (August 2024)	Page
• Added DGS package to <i>Device Information</i> table, <i>Pin Configuration and Functions</i> section, and <i>Thermal Information</i> table.....	1
• Added package size to <i>Device Information</i> table.....	1
• Added <i>Application and Implementation</i> section.....	9

Changes from Revision F (January 2022) to Revision G (July 2022)	Page
• Junction-to-ambient thermal resistance values increased. DW was 58 is now 109.1, DB was 70 is now 122.7, N was 69 is now 84.6, NS was 60 is now 113.4, PW was 83 is now 131.8.....	4

## 10 Mechanical, Packaging, and Orderable Information

The following pages include mechanical, packaging, and orderable information. This information is the most current data available for the designated devices. This data is subject to change without notice and revision of this document. For browser-based versions of this data sheet, refer to the left-hand navigation.

**PACKAGING INFORMATION**

Orderable part number	Status (1)	Material type (2)	Package   Pins	Package qty   Carrier	RoHS (3)	Lead finish/ Ball material (4)	MSL rating/ Peak reflow (5)	Op temp (°C)	Part marking (6)
<a href="#">SN74HCT574DBR</a>	Active	Production	SSOP (DB)   20	2000   LARGE T&R	Yes	NIPDAU	Level-1-260C-UNLIM	-40 to 85	HT574
SN74HCT574DBR.A	Active	Production	SSOP (DB)   20	2000   LARGE T&R	Yes	NIPDAU	Level-1-260C-UNLIM	-40 to 125	HT574
<a href="#">SN74HCT574DGSR</a>	Active	Production	VSSOP (DGS)   20	5000   LARGE T&R	Yes	NIPDAU	Level-1-260C-UNLIM	-40 to 125	HT574
SN74HCT574DGSR.A	Active	Production	VSSOP (DGS)   20	5000   LARGE T&R	Yes	NIPDAU	Level-1-260C-UNLIM	-40 to 125	HT574
<a href="#">SN74HCT574DW</a>	Obsolete	Production	SOIC (DW)   20	-	-	Call TI	Call TI	-40 to 85	HCT574
<a href="#">SN74HCT574DWR</a>	Active	Production	SOIC (DW)   20	2000   LARGE T&R	Yes	NIPDAU	Level-1-260C-UNLIM	-40 to 85	HCT574
SN74HCT574DWR.A	Active	Production	SOIC (DW)   20	2000   LARGE T&R	Yes	NIPDAU	Level-1-260C-UNLIM	-40 to 125	HCT574
SN74HCT574DWRG4	Active	Production	SOIC (DW)   20	2000   LARGE T&R	Yes	NIPDAU	Level-1-260C-UNLIM	-40 to 85	HCT574
<a href="#">SN74HCT574N</a>	Active	Production	PDIP (N)   20	20   TUBE	Yes	NIPDAU	N/A for Pkg Type	-40 to 85	SN74HCT574N
SN74HCT574N.A	Active	Production	PDIP (N)   20	20   TUBE	Yes	NIPDAU	N/A for Pkg Type	-40 to 125	SN74HCT574N
SN74HCT574NE4	Active	Production	PDIP (N)   20	20   TUBE	Yes	NIPDAU	N/A for Pkg Type	-40 to 85	SN74HCT574N
<a href="#">SN74HCT574NSR</a>	Active	Production	SOP (NS)   20	2000   LARGE T&R	Yes	NIPDAU   NIPDAU	Level-1-260C-UNLIM	-40 to 85	HCT574
SN74HCT574NSR.A	Active	Production	SOP (NS)   20	2000   LARGE T&R	Yes	NIPDAU	Level-1-260C-UNLIM	-40 to 125	HCT574
<a href="#">SN74HCT574PW</a>	Obsolete	Production	TSSOP (PW)   20	-	-	Call TI	Call TI	-40 to 85	HT574
<a href="#">SN74HCT574PWR</a>	Active	Production	TSSOP (PW)   20	2000   LARGE T&R	Yes	NIPDAU   NIPDAU	Level-1-260C-UNLIM	-40 to 85	HT574
SN74HCT574PWR.A	Active	Production	TSSOP (PW)   20	2000   LARGE T&R	Yes	NIPDAU	Level-1-260C-UNLIM	-40 to 125	HT574
<a href="#">SN74HCT574PWT</a>	Obsolete	Production	TSSOP (PW)   20	-	-	Call TI	Call TI	-40 to 85	HT574

(1) **Status:** For more details on status, see our [product life cycle](#).

(2) **Material type:** When designated, preproduction parts are prototypes/experimental devices, and are not yet approved or released for full production. Testing and final process, including without limitation quality assurance, reliability performance testing, and/or process qualification, may not yet be complete, and this item is subject to further changes or possible discontinuation. If available for ordering, purchases will be subject to an additional waiver at checkout, and are intended for early internal evaluation purposes only. These items are sold without warranties of any kind.

(3) **RoHS values:** Yes, No, RoHS Exempt. See the [TI RoHS Statement](#) for additional information and value definition.

(4) **Lead finish/Ball material:** Parts may have multiple material finish options. Finish options are separated by a vertical ruled line. Lead finish/Ball material values may wrap to two lines if the finish value exceeds the maximum column width.

(5) **MSL rating/Peak reflow:** The moisture sensitivity level ratings and peak solder (reflow) temperatures. In the event that a part has multiple moisture sensitivity ratings, only the lowest level per JEDEC standards is shown. Refer to the shipping label for the actual reflow temperature that will be used to mount the part to the printed circuit board.

**(6) Part marking:** There may be an additional marking, which relates to the logo, the lot trace code information, or the environmental category of the part.

Multiple part markings will be inside parentheses. Only one part marking contained in parentheses and separated by a "~" will appear on a part. If a line is indented then it is a continuation of the previous line and the two combined represent the entire part marking for that device.

**Important Information and Disclaimer:** The information provided on this page represents TI's knowledge and belief as of the date that it is provided. TI bases its knowledge and belief on information provided by third parties, and makes no representation or warranty as to the accuracy of such information. Efforts are underway to better integrate information from third parties. TI has taken and continues to take reasonable steps to provide representative and accurate information but may not have conducted destructive testing or chemical analysis on incoming materials and chemicals. TI and TI suppliers consider certain information to be proprietary, and thus CAS numbers and other limited information may not be available for release.

In no event shall TI's liability arising out of such information exceed the total purchase price of the TI part(s) at issue in this document sold by TI to Customer on an annual basis.

**TAPE AND REEL INFORMATION**

**QUADRANT ASSIGNMENTS FOR PIN 1 ORIENTATION IN TAPE**

\*All dimensions are nominal

Device	Package Type	Package Drawing	Pins	SPQ	Reel Diameter (mm)	Reel Width W1 (mm)	A0 (mm)	B0 (mm)	K0 (mm)	P1 (mm)	W (mm)	Pin1 Quadrant
SN74HCT574DBR	SSOP	DB	20	2000	330.0	16.4	8.2	7.5	2.5	12.0	16.0	Q1
SN74HCT574DGSR	VSSOP	DGS	20	5000	330.0	16.4	5.4	5.4	1.45	8.0	16.0	Q1
SN74HCT574DWR	SOIC	DW	20	2000	330.0	24.4	10.9	13.3	2.7	12.0	24.0	Q1
SN74HCT574DWR	SOIC	DW	20	2000	330.0	24.4	10.9	13.3	2.7	12.0	24.0	Q1
SN74HCT574NSR	SOP	NS	20	2000	330.0	24.4	8.4	13.0	2.5	12.0	24.0	Q1
SN74HCT574PWR	TSSOP	PW	20	2000	330.0	16.4	6.95	7.0	1.4	8.0	16.0	Q1

**TAPE AND REEL BOX DIMENSIONS**

\*All dimensions are nominal

Device	Package Type	Package Drawing	Pins	SPQ	Length (mm)	Width (mm)	Height (mm)
SN74HCT574DBR	SSOP	DB	20	2000	356.0	356.0	35.0
SN74HCT574DGSR	VSSOP	DGS	20	5000	353.0	353.0	32.0
SN74HCT574DWR	SOIC	DW	20	2000	367.0	367.0	45.0
SN74HCT574DWR	SOIC	DW	20	2000	356.0	356.0	41.0
SN74HCT574NSR	SOP	NS	20	2000	367.0	367.0	45.0
SN74HCT574PWR	TSSOP	PW	20	2000	356.0	356.0	35.0

**TUBE**

\*All dimensions are nominal

Device	Package Name	Package Type	Pins	SPQ	L (mm)	W (mm)	T (μm)	B (mm)
SN74HCT574N	N	PDIP	20	20	506	13.97	11230	4.32
SN74HCT574N.A	N	PDIP	20	20	506	13.97	11230	4.32
SN74HCT574NE4	N	PDIP	20	20	506	13.97	11230	4.32

PW0020A



**PACKAGE OUTLINE**  
**TSSOP - 1.2 mm max height**

SMALL OUTLINE PACKAGE



4220206/A 02/2017

NOTES:

1. All linear dimensions are in millimeters. Any dimensions in parenthesis are for reference only. Dimensioning and tolerancing per ASME Y14.5M.
2. This drawing is subject to change without notice.
3. This dimension does not include mold flash, protrusions, or gate burrs. Mold flash, protrusions, or gate burrs shall not exceed 0.15 mm per side.
4. This dimension does not include interlead flash. Interlead flash shall not exceed 0.25 mm per side.
5. Reference JEDEC registration MO-153.

# EXAMPLE BOARD LAYOUT

PW0020A

TSSOP - 1.2 mm max height

SMALL OUTLINE PACKAGE



LAND PATTERN EXAMPLE  
EXPOSED METAL SHOWN  
SCALE: 10X



SOLDER MASK DETAILS

4220206/A 02/2017

NOTES: (continued)

6. Publication IPC-7351 may have alternate designs.
7. Solder mask tolerances between and around signal pads can vary based on board fabrication site.

# EXAMPLE STENCIL DESIGN

PW0020A

TSSOP - 1.2 mm max height

SMALL OUTLINE PACKAGE



SOLDER PASTE EXAMPLE  
BASED ON 0.125 mm THICK STENCIL  
SCALE: 10X

4220206/A 02/2017

NOTES: (continued)

8. Laser cutting apertures with trapezoidal walls and rounded corners may offer better paste release. IPC-7525 may have alternate design recommendations.
9. Board assembly site may have different recommendations for stencil design.

# DGS0020A



# PACKAGE OUTLINE

VSSOP - 1.1 mm max height

SMALL OUTLINE PACKAGE

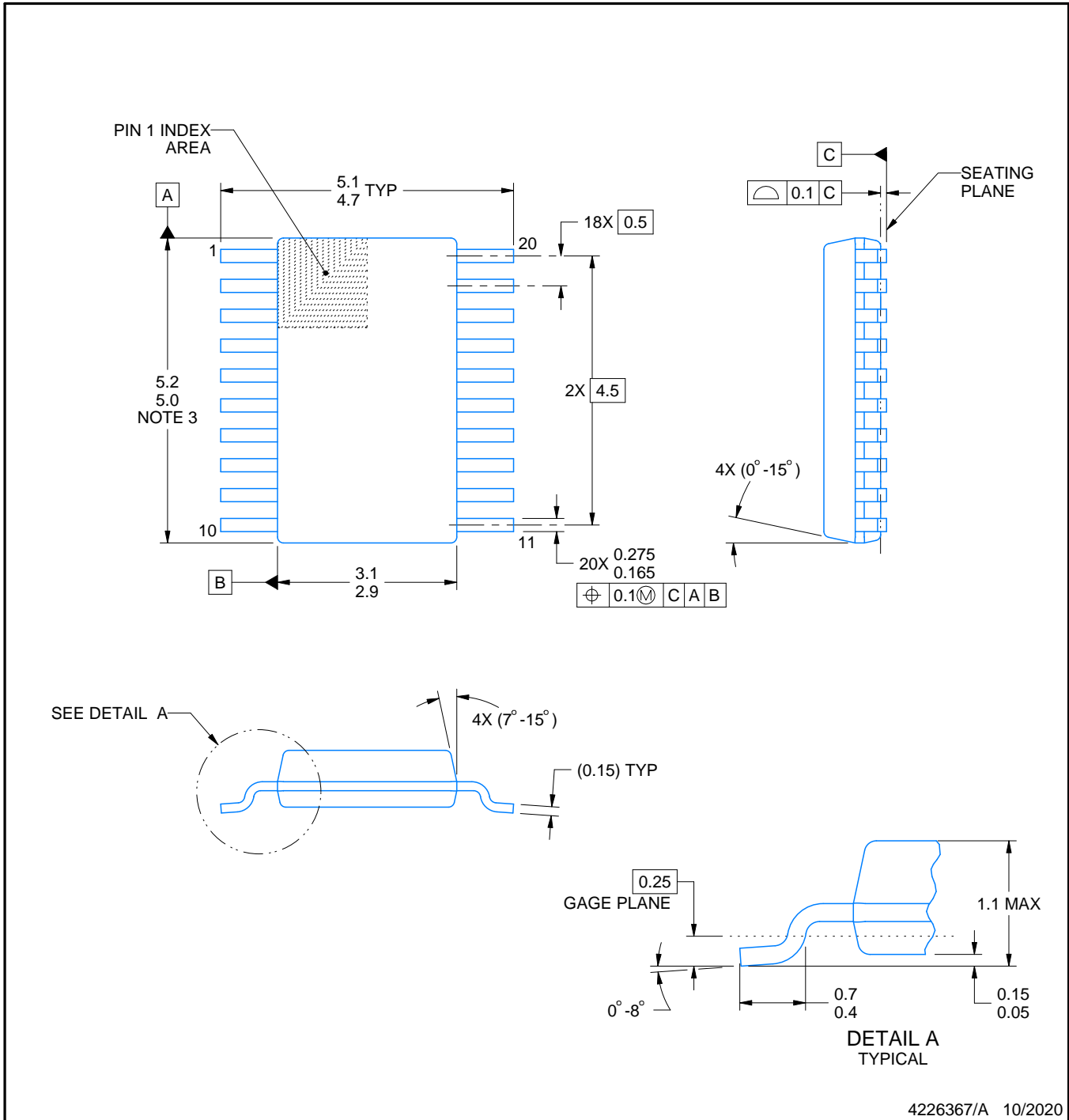

4226367/A 10/2020

**NOTES:**

PowerPAD is a trademark of Texas Instruments.

1. All linear dimensions are in millimeters. Any dimensions in parenthesis are for reference only. Dimensioning and tolerancing per ASME Y14.5M.
2. This drawing is subject to change without notice.
3. This dimension does not include mold flash, protrusions, or gate burrs. Mold flash, protrusions, or gate burrs shall not exceed 0.15 mm per side.
4. No JEDEC registration as of September 2020.
5. Features may differ or may not be present.

# EXAMPLE BOARD LAYOUT

DGS0020A

VSSOP - 1.1 mm max height

SMALL OUTLINE PACKAGE

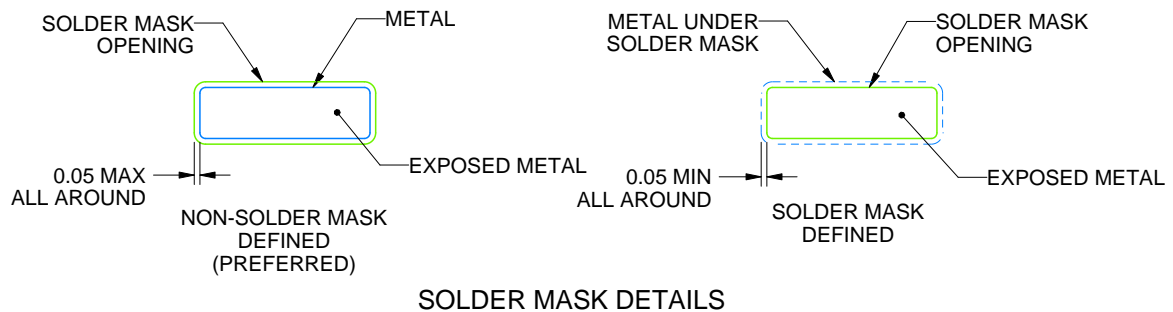
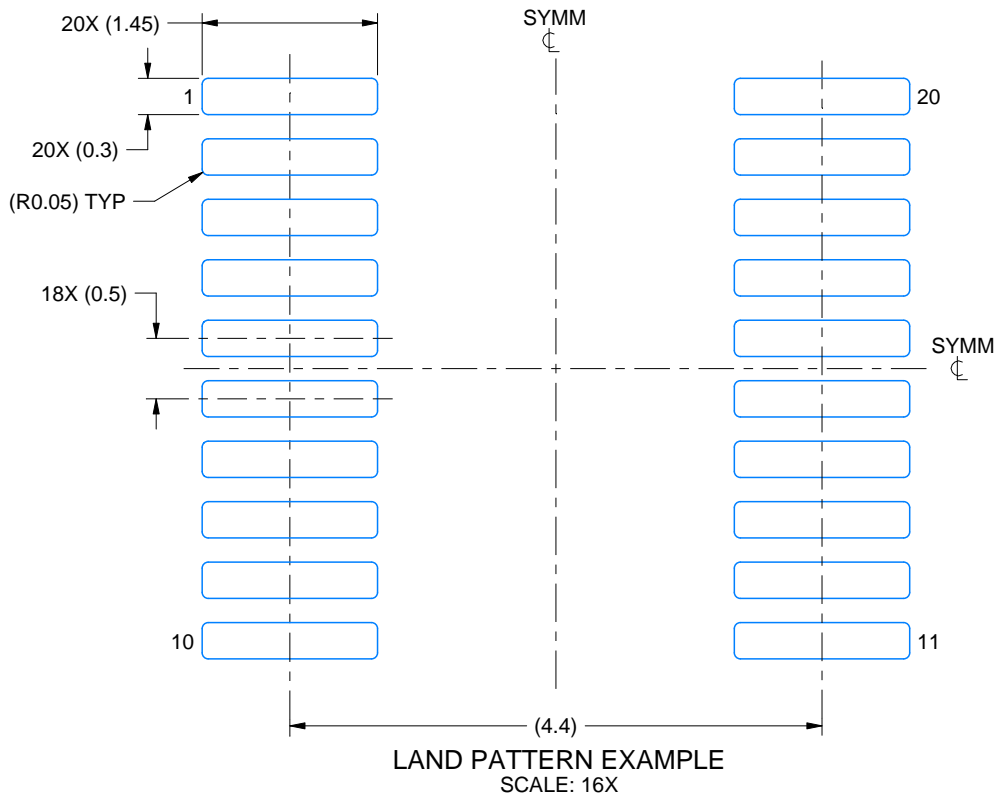

4226367/A 10/2020

NOTES: (continued)

6. Publication IPC-7351 may have alternate designs.
7. Solder mask tolerances between and around signal pads can vary based on board fabrication site.
8. This package is designed to be soldered to a thermal pad on the board. For more information, see Texas Instruments literature numbers SLMA002 ([www.ti.com/lit/slma002](http://www.ti.com/lit/slma002)) and SLMA004 ([www.ti.com/lit/slma004](http://www.ti.com/lit/slma004)).
9. Size of metal pad may vary due to creepage requirement.
10. Vias are optional depending on application, refer to device data sheet. It is recommended that vias under paste be filled, plugged or tented.

# EXAMPLE STENCIL DESIGN

DGS0020A

VSSOP - 1.1 mm max height

SMALL OUTLINE PACKAGE

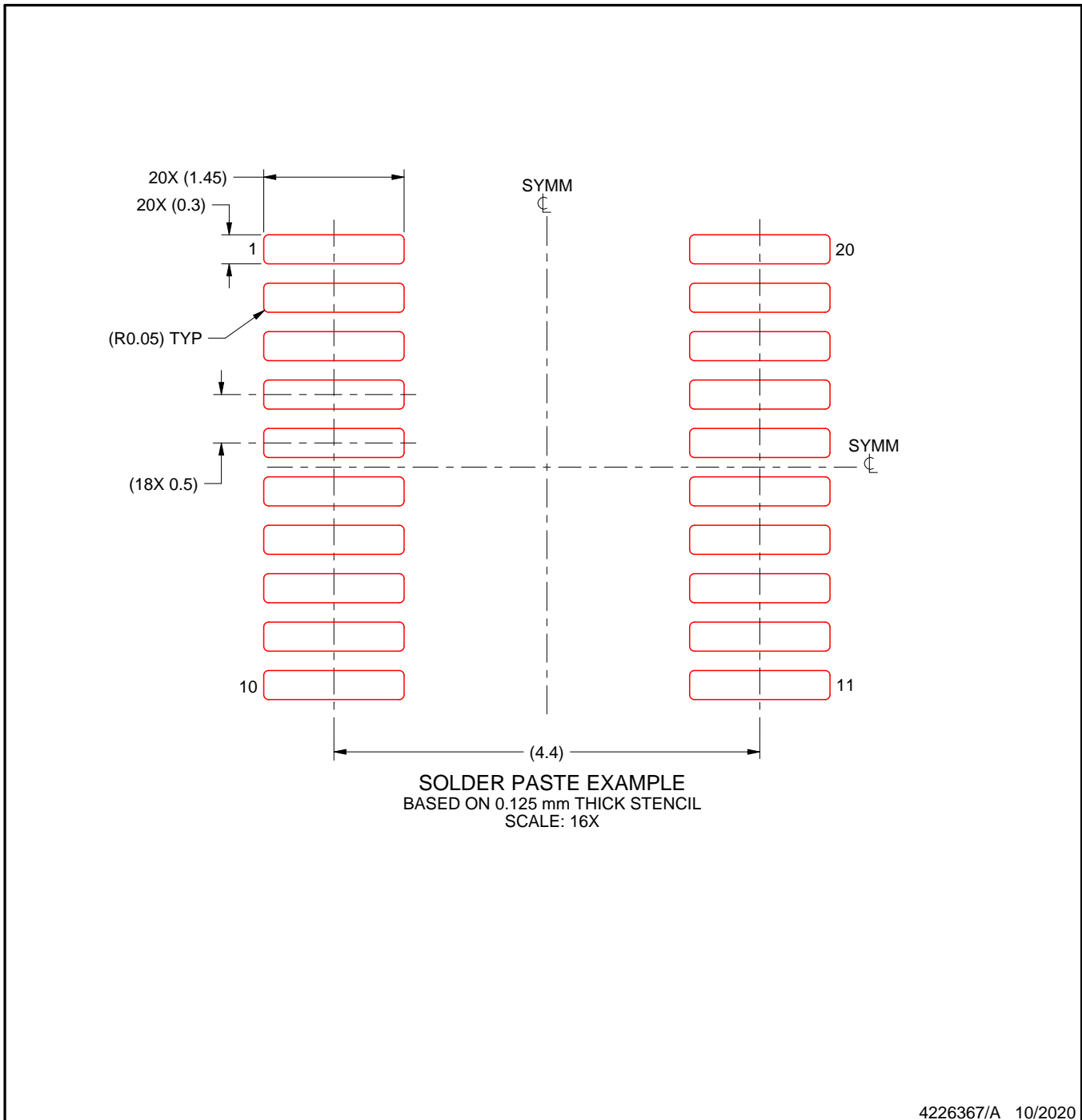

NOTES: (continued)

11. Laser cutting apertures with trapezoidal walls and rounded corners may offer better paste release. IPC-7525 may have alternate design recommendations.
12. Board assembly site may have different recommendations for stencil design.

# DB0020A



# PACKAGE OUTLINE

## SSOP - 2 mm max height

SMALL OUTLINE PACKAGE



4214851/B 08/2019

# EXAMPLE BOARD LAYOUT

DB0020A

SSOP - 2 mm max height

SMALL OUTLINE PACKAGE



LAND PATTERN EXAMPLE  
EXPOSED METAL SHOWN  
SCALE: 10X

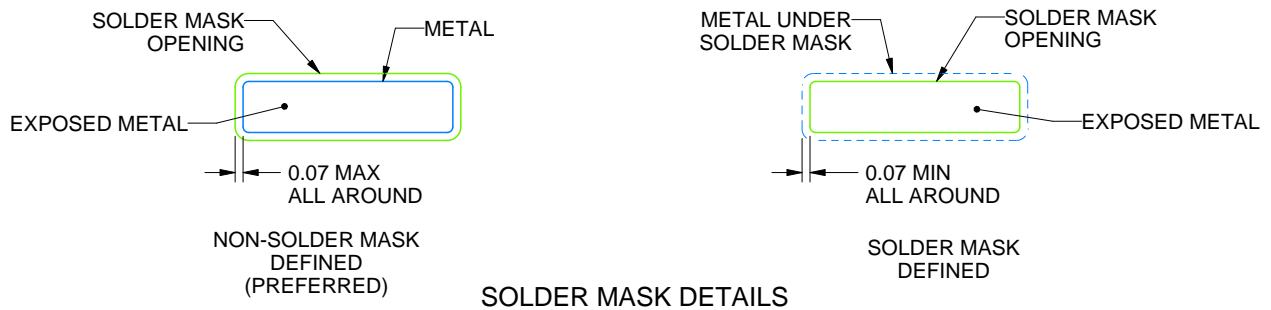

4214851/B 08/2019

NOTES: (continued)

- 6. Publication IPC-7351 may have alternate designs.
- 7. Solder mask tolerances between and around signal pads can vary based on board fabrication site.

# EXAMPLE STENCIL DESIGN

DB0020A

SSOP - 2 mm max height

SMALL OUTLINE PACKAGE



SOLDER PASTE EXAMPLE  
BASED ON 0.125 mm THICK STENCIL  
SCALE: 10X

4214851/B 08/2019

NOTES: (continued)

8. Laser cutting apertures with trapezoidal walls and rounded corners may offer better paste release. IPC-7525 may have alternate design recommendations.
9. Board assembly site may have different recommendations for stencil design.

# MECHANICAL DATA

NS (R-PDSO-G\*\*)

PLASTIC SMALL-OUTLINE PACKAGE

14-PINS SHOWN



- NOTES:
- A. All linear dimensions are in millimeters.
  - B. This drawing is subject to change without notice.
  - C. Body dimensions do not include mold flash or protrusion, not to exceed 0,15.

N (R-PDIP-T\*\*)

PLASTIC DUAL-IN-LINE PACKAGE

16 PINS SHOWN



- NOTES:
- A. All linear dimensions are in inches (millimeters).
  - B. This drawing is subject to change without notice.
  - Falls within JEDEC MS-001, except 18 and 20 pin minimum body length (Dim A).
  - The 20 pin end lead shoulder width is a vendor option, either half or full width.



# EXAMPLE BOARD LAYOUT

DW0020A

SOIC - 2.65 mm max height

SOIC



LAND PATTERN EXAMPLE  
SCALE:6X



SOLDER MASK DETAILS

4220724/A 05/2016

NOTES: (continued)

- 6. Publication IPC-7351 may have alternate designs.
- 7. Solder mask tolerances between and around signal pads can vary based on board fabrication site.

# EXAMPLE STENCIL DESIGN

DW0020A

SOIC - 2.65 mm max height

SOIC



SOLDER PASTE EXAMPLE  
BASED ON 0.125 mm THICK STENCIL  
SCALE:6X

4220724/A 05/2016

NOTES: (continued)

8. Laser cutting apertures with trapezoidal walls and rounded corners may offer better paste release. IPC-7525 may have alternate design recommendations.
9. Board assembly site may have different recommendations for stencil design.

## IMPORTANT NOTICE AND DISCLAIMER

TI PROVIDES TECHNICAL AND RELIABILITY DATA (INCLUDING DATA SHEETS), DESIGN RESOURCES (INCLUDING REFERENCE DESIGNS), APPLICATION OR OTHER DESIGN ADVICE, WEB TOOLS, SAFETY INFORMATION, AND OTHER RESOURCES "AS IS" AND WITH ALL FAULTS, AND DISCLAIMS ALL WARRANTIES, EXPRESS AND IMPLIED, INCLUDING WITHOUT LIMITATION ANY IMPLIED WARRANTIES OF MERCHANTABILITY, FITNESS FOR A PARTICULAR PURPOSE OR NON-INFRINGEMENT OF THIRD PARTY INTELLECTUAL PROPERTY RIGHTS.

These resources are intended for skilled developers designing with TI products. You are solely responsible for (1) selecting the appropriate TI products for your application, (2) designing, validating and testing your application, and (3) ensuring your application meets applicable standards, and any other safety, security, regulatory or other requirements.

These resources are subject to change without notice. TI grants you permission to use these resources only for development of an application that uses the TI products described in the resource. Other reproduction and display of these resources is prohibited. No license is granted to any other TI intellectual property right or to any third party intellectual property right. TI disclaims responsibility for, and you will fully indemnify TI and its representatives against, any claims, damages, costs, losses, and liabilities arising out of your use of these resources.

TI's products are provided subject to [TI's Terms of Sale](#) or other applicable terms available either on [ti.com](https://www.ti.com) or provided in conjunction with such TI products. TI's provision of these resources does not expand or otherwise alter TI's applicable warranties or warranty disclaimers for TI products.

TI objects to and rejects any additional or different terms you may have proposed.

Mailing Address: Texas Instruments, Post Office Box 655303, Dallas, Texas 75265  
Copyright © 2025, Texas Instruments Incorporated