

SN55461 THRU SN55463 SN75461 THRU SN75463 DUAL PERIPHERAL DRIVERS

SLRS022A – DECEMBER 1976 – REVISED OCTOBER 1995

PERIPHERAL DRIVERS FOR HIGH-VOLTAGE, HIGH-CURRENT DRIVER APPLICATIONS

- Characterized for Use to 300 mA
- High-Voltage Outputs
- No Output Latch-Up at 30 V (After Conducting 300 mA)
- Medium-Speed Switching
- Circuit Flexibility for Varied Applications and Choice of Logic Function
- TTL-Compatible Diode-Clamped Inputs
- Standard Supply Voltages
- Plastic DIP (P) With Copper Lead Frame for Cooler Operation and Improved Reliability
- Package Options Include Plastic Small Outline Packages, Ceramic Chip Carriers, and Standard Plastic and Ceramic 300-mil DIPs

SUMMARY OF SERIES 55461/75461

DEVICE	LOGIC	PACKAGES
SN55461	AND	FK, JG
SN55462	NAND	FK, JG
SN55463	OR	FK, JG
SN75461	AND	D, P
SN75462	NAND	D, P
SN75463	OR	D, P

SN55461, SN55462, SN55463 . . . JG PACKAGE
SN75461, SN75462, SN75463 . . . D OR P PACKAGE
(TOP VIEW)

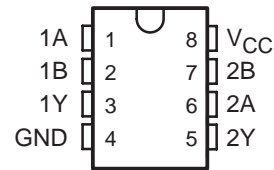

SN55461, SN55462, SN55463 . . . FK PACKAGE
(TOP VIEW)

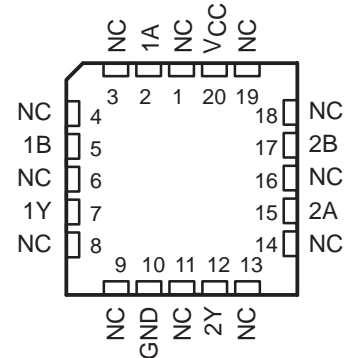

NC – No internal connection

description

These dual peripheral drivers are functionally interchangeable with SN55451B through SN55453B and SN75451B through SN75453B peripheral drivers, but are designed for use in systems that require higher breakdown voltages than those devices can provide at the expense of slightly slower switching speeds. Typical applications include logic buffers, power drivers, relay drivers, lamp drivers, MOS drivers, line drivers, and memory drivers.

The SN55461/SN75461, SN55462/SN75462, and SN55463/SN75463 are dual peripheral AND, NAND, and OR drivers respectively (assuming positive logic), with the output of the gates internally connected to the bases of the npn output transistors.

Series SN55461 drivers are characterized for operation over the full military temperature range of -55°C to 125°C . Series SN75461 drivers are characterized for operation from 0°C to 70°C .

SN55461 THRU SN55463 SN75461 THRU SN75463 DUAL PERIPHERAL DRIVERS

SLRS022A – DECEMBER 1976 – REVISED OCTOBER 1995

absolute maximum ratings over operating free-air temperature range (unless otherwise noted)†

	SN55'	SN75'	UNIT
Supply voltage, V_{CC} (see Note 1)	7	7	V
Input voltage, V_I	5.5	5.5	V
Intermitter voltage (see Note 2)	5.5	5.5	V
Off-state output voltage, V_O	35	35	V
Continuous collector or output current (see Note 3)	400	400	mA
Peak collector or output current ($t_W \leq 10$ ms, duty cycle $\leq 50\%$, see Note 4)	500	500	mA
Continuous total power dissipation	See Dissipation Rating Table		
Operating free-air temperature range, T_A	-55 to 125	0 to 70	°C
Storage temperature range, T_{STG}	-65 to 150	-65 to 150	°C
Case temperature for 60 seconds, T_C	FK package	260	°C
Lead temperature 1,6 mm (1/16 inch) from case for 60 seconds	JG package	300	°C
Lead temperature 1,6 mm (1/16 inch) from case for 10 seconds	D or P package	260	°C

† Stresses beyond those listed under "absolute maximum ratings" may cause permanent damage to the device. These are stress ratings only, and functional operation of the device at these or any other conditions beyond those indicated under "recommended operating conditions" is not implied. Exposure to absolute-maximum-rated conditions for extended periods may affect device reliability.

- NOTES:
1. Voltage values are with respect to network GND unless otherwise specified.
 2. This is the voltage between two emitters A and B.
 3. This value applies when the base-emitter resistance (R_{BE}) is equal to or less than 500 Ω .
 4. Both halves of these dual circuits may conduct rated current simultaneously; however, power dissipation averaged over a short time interval must fall within the continuous dissipation rating.

DISSIPATION RATING TABLE

PACKAGE	$T_A \leq 25^\circ\text{C}$	DERATING FACTOR	$T_A = 70^\circ\text{C}$	$T_A = 125^\circ\text{C}$
	POWER RATING	ABOVE $T_A = 25^\circ\text{C}$	POWER RATING	POWER RATING
D	725 mW	5.8 mW/°C	464 mW	–
FK	1375 mW	11.0 mW/°C	880 mW	275 mW
JG	1050 mW	8.4 mW/°C	672 mW	210 mW
P	1000 mW	8.0 mW/°C	640 mW	–

recommended operating conditions

	SN55'			SN75'			UNIT
	MIN	NOM	MAX	MIN	NOM	MAX	
Supply voltage, V_{CC}	4.5	5	5.5	4.75	5	5.25	V
High-level input voltage, V_{IH}	2			2			V
Low-level input voltage, V_{IL}			0.8			0.8	V
Operating free-air temperature, T_A	-55		125	0		70	°C



SN55461 THRU SN55463 SN75461 THRU SN75463 DUAL PERIPHERAL DRIVERS

SLRS022A – DECEMBER 1976 – REVISED OCTOBER 1995

logic symbol†



† This symbol is in accordance with ANSI/IEEE Std 91-1984 and IEC Publication 617-12. Pin numbers shown are for D, JG, and P packages.

logic diagram (positive logic)

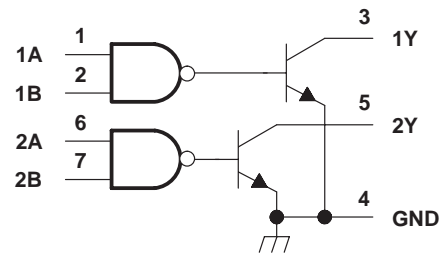

FUNCTION TABLE
(each driver)

A	B	Y
L	L	L (on state)
L	H	L (on state)
H	L	L (on state)
H	H	H (off state)

positive logic: $Y = AB$ or $\overline{A + B}$

schematic (each driver)

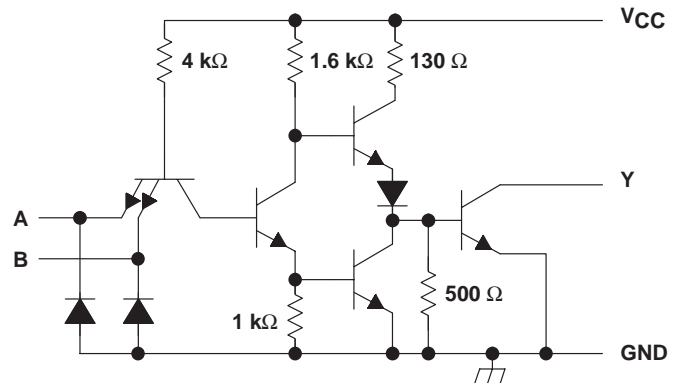

Resistor values shown are nominal.

electrical characteristics over recommended operating free-air temperature range

PARAMETER	TEST CONDITIONS†	SN55461		SN75461		UNIT	
		MIN	TYP‡	MAX	MIN		TYP‡
V_{IK} Input clamp voltage	$V_{CC} = \text{MIN}$, $I_I = -12 \text{ mA}$		-1.2	-1.5	-1.2	-1.5	V
I_{OH} High-level output current	$V_{CC} = \text{MIN}$, $V_{IH} = \text{MIN}$, $V_{OH} = 35 \text{ V}$			300		100	μA
V_{OL} Low-level output voltage	$V_{CC} = \text{MIN}$, $V_{IL} = 0.8 \text{ V}$, $I_{OL} = 100 \text{ mA}$		0.25	0.5	0.25	0.4	V
	$V_{CC} = \text{MIN}$, $V_{IL} = 0.8 \text{ V}$, $I_{OL} = 300 \text{ mA}$		0.5	0.8	0.5	0.7	
I_I Input current at maximum input voltage	$V_{CC} = \text{MAX}$, $V_I = 5.5 \text{ V}$			1		1	mA
I_{IH} High-level input current	$V_{CC} = \text{MAX}$, $V_I = 2.4 \text{ V}$			40		40	μA
I_{IL} Low-level input current	$V_{CC} = \text{MAX}$, $V_I = 0.4 \text{ V}$		-1	-1.6	-1	-1.6	mA
I_{CCH} Supply current, outputs high	$V_{CC} = \text{MAX}$, $V_I = 5 \text{ V}$		8	11	8	11	mA
I_{CCL} Supply current, outputs low	$V_{CC} = \text{MAX}$, $V_I = 0$		56	76	56	76	mA

† For conditions shown as MIN or MAX, use the appropriate value specified under recommended operating conditions.

‡ All typical values are at $V_{CC} = 5 \text{ V}$, $T_A = 25^\circ\text{C}$.

switching characteristics, $V_{CC} = 5 \text{ V}$, $T_A = 25^\circ\text{C}$

PARAMETER	TEST CONDITIONS	MIN	TYP	MAX	UNIT
t_{PLH} Propagation delay time, low-to-high-level output	$I_O \approx 200 \text{ mA}$, $C_L = 15 \text{ pF}$, $R_L = 50 \Omega$, See Figure 1		30	55	ns
t_{PHL} Propagation delay time, high-to-low-level output			25	40	
t_{TLH} Transition time, low-to-high-level output			8	20	
t_{THL} Transition time, high-to-low-level output			10	20	
V_{OH} High-level output voltage after switching	SN55461	$V_S - 10$		mV	
	SN75461	$V_S - 10$			



SN55461 THRU SN55463 SN75461 THRU SN75463 DUAL PERIPHERAL DRIVERS

SLRS022A – DECEMBER 1976 – REVISED OCTOBER 1995

logic symbol†



† This symbol is in accordance with ANSI/IEEE Std 91-1984 and IEC Publication 617-12.
Pin numbers shown are for D, JG, and P packages.

logic diagram (positive logic)

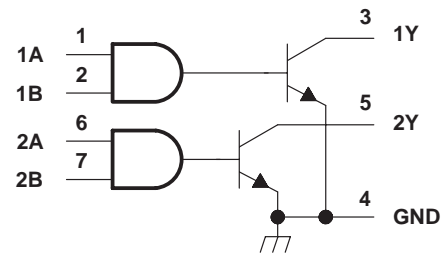

FUNCTION TABLE
(each driver)

A	B	Y
L	L	H (off state)
L	H	H (off state)
H	L	H (off state)
H	H	L (on state)

positive logic:
 $Y = \overline{AB}$ or $\overline{A + B}$

schematic (each driver)

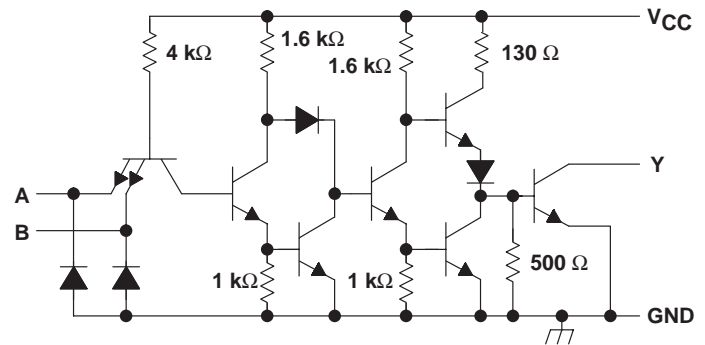

Resistor values shown are nominal.

electrical characteristics over recommended operating free-air temperature range

PARAMETER	TEST CONDITIONS†	SN55462		SN75462		UNIT
		MIN	TYP‡	MAX	MIN	
V_{IK} Input clamp voltage	$V_{CC} = \text{MIN}$, $I_I = -12 \text{ mA}$	-1.2	-1.5	-1.2	-1.5	V
I_{OH} High-level output current	$V_{CC} = \text{MIN}$, $V_{IL} = 0.8 \text{ V}$, $V_{OH} = 35 \text{ V}$		300		100	μA
V_{OL} Low-level output voltage	$V_{CC} = \text{MIN}$, $V_{IH} = \text{MIN}$, $I_{OL} = 100 \text{ mA}$	0.25	0.5	0.25	0.4	V
	$V_{CC} = \text{MIN}$, $V_{IH} = \text{MIN}$, $I_{OL} = 300 \text{ mA}$	0.5	0.8	0.5	0.7	
I_I Input current at maximum input voltage	$V_{CC} = \text{MAX}$, $V_I = 5.5 \text{ V}$		1		1	mA
I_{IH} High-level input current	$V_{CC} = \text{MAX}$, $V_I = 2.4 \text{ V}$		40		40	μA
I_{IL} Low-level input current	$V_{CC} = \text{MAX}$, $V_I = 0.4 \text{ V}$	-1.1	-1.6	-1.1	-1.6	mA
I_{CCH} Supply current, outputs high	$V_{CC} = \text{MAX}$, $V_I = 0$	13	17	13	17	mA
I_{CCL} Supply current, outputs low	$V_{CC} = \text{MAX}$, $V_I = 5 \text{ V}$	61	76	61	76	mA

† For conditions shown as MIN or MAX, use the appropriate value specified under recommended operating conditions.

‡ All typical values are at $V_{CC} = 5 \text{ V}$, $T_A = 25^\circ\text{C}$.

switching characteristics, $V_{CC} = 5 \text{ V}$, $T_A = 25^\circ\text{C}$

PARAMETER	TEST CONDITIONS	MIN	TYP	MAX	UNIT
t_{PLH} Propagation delay time, low-to-high-level output	$I_O \approx 200 \text{ mA}$, $C_L = 15 \text{ pF}$, $R_L = 50 \Omega$, See Figure 1		45	65	ns
t_{PHL} Propagation delay time, high-to-low-level output			30	50	
t_{TLH} Transition time, low-to-high-level output			13	25	
t_{THL} Transition time, high-to-low-level output			10	20	
V_{OH} High-level output voltage after switching	SN55462	$V_S - 10$			mV
	SN75462	$V_S - 10$			



SN55461 THRU SN55463 SN75461 THRU SN75463 DUAL PERIPHERAL DRIVERS

SLRS022A – DECEMBER 1976 – REVISED OCTOBER 1995

logic symbol†



† This symbol is in accordance with ANSI/IEEE Std 91-1984 and IEC Publication 617-12. Pin numbers shown are for D, JG, and P packages.

logic diagram (positive logic)

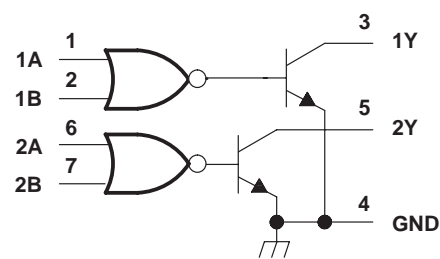

FUNCTION TABLE
(each driver)

A	B	Y
L	L	L (on state)
L	H	H (off state)
H	L	H (off state)
H	H	H (off state)

positive logic:
 $Y = A + B \text{ or } \overline{A} \overline{B}$

schematic (each driver)

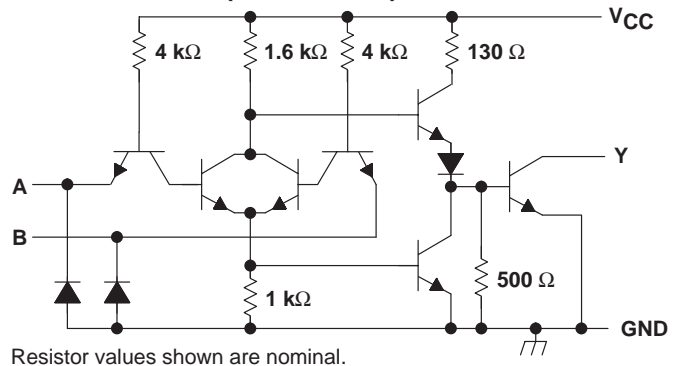

Resistor values shown are nominal.

electrical characteristics over recommended operating free-air temperature range

PARAMETER	TEST CONDITIONS†	SN55463		SN75463		UNIT
		MIN	TYP‡	MAX	MIN	
V_{IK} Input clamp voltage	$V_{CC} = \text{MIN}, I_I = -12 \text{ mA}$	-1.2	-1.5	-1.2	-1.5	V
I_{OH} High-level output current	$V_{CC} = \text{MIN}, V_{IH} = \text{MIN}, V_{OH} = 35 \text{ V}$		300		100	μA
V_{OL} Low-level output voltage	$V_{CC} = \text{MIN}, V_{IL} = 0.8 \text{ V}, I_{OL} = 100 \text{ mA}$	0.25	0.5	0.25	0.4	V
	$V_{CC} = \text{MIN}, V_{IL} = 0.8 \text{ V}, I_{OL} = 300 \text{ mA}$	0.5	0.8	0.5	0.7	
I_I Input current at maximum input voltage	$V_{CC} = \text{MAX}, V_I = 5.5 \text{ V}$		1		1	mA
I_{IH} High-level input current	$V_{CC} = \text{MAX}, V_I = 2.4 \text{ V}$		40		40	μA
I_{IL} Low-level input current	$V_{CC} = \text{MAX}, V_I = 0.4 \text{ V}$	-1	-1.6	-1	-1.6	mA
I_{CCH} Supply current, outputs high	$V_{CC} = \text{MAX}, V_I = 5 \text{ V}$	8	11	8	11	mA
I_{CCL} Supply current, outputs low	$V_{CC} = \text{MAX}, V_I = 0$	58	76	58	76	mA

† For conditions shown as MIN or MAX, use the appropriate value specified under recommended operating conditions.

‡ All typical values are at $V_{CC} = 5 \text{ V}, T_A = 25^\circ\text{C}$.

switching characteristics, $V_{CC} = 5 \text{ V}, T_A = 25^\circ\text{C}$

PARAMETER	TEST CONDITIONS	MIN	TYP	MAX	UNIT
t_{PLH} Propagation delay time, low-to-high-level output	$I_O \approx 200 \text{ mA}, C_L = 15 \text{ pF}, R_L = 50 \Omega,$ See Figure 1		30	55	ns
t_{PHL} Propagation delay time, high-to-low-level output			25	40	
t_{TLH} Transition time, low-to-high-level output			8	25	
t_{THL} Transition time, high-to-low-level output			10	25	
V_{OH} High-level output voltage after switching	SN55463	$V_S - 10$		mV	
	SN75463	$V_S - 10$			



POST OFFICE BOX 655303 • DALLAS, TEXAS 75265
POST OFFICE BOX 1443 • HOUSTON, TEXAS 77251-1443

SN55461 THRU SN55463
SN75461 THRU SN75463
DUAL PERIPHERAL DRIVERS

SLRS022A – DECEMBER 1976 – REVISED OCTOBER 1995

PARAMETER MEASUREMENT INFORMATION

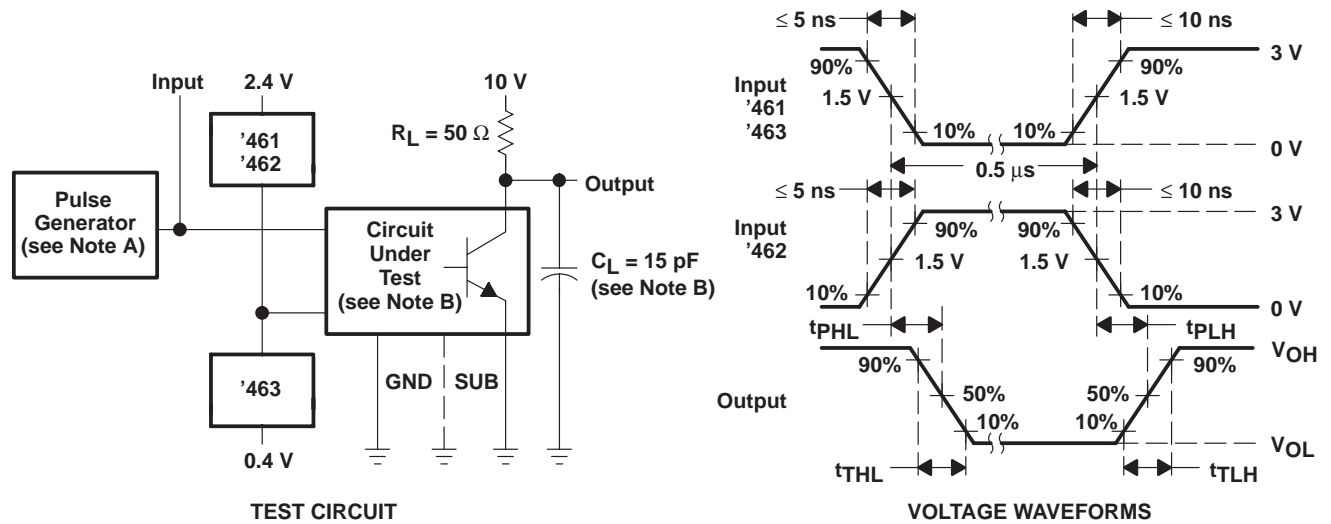

- NOTES: A. The pulse generator has the following characteristics: PRR \leq 1 MHz, $Z_O \approx 50 \Omega$.
 B. C_L includes probe and jig capacitance.

Figure 1. Test Circuit and Voltage Waveforms for Switching Times

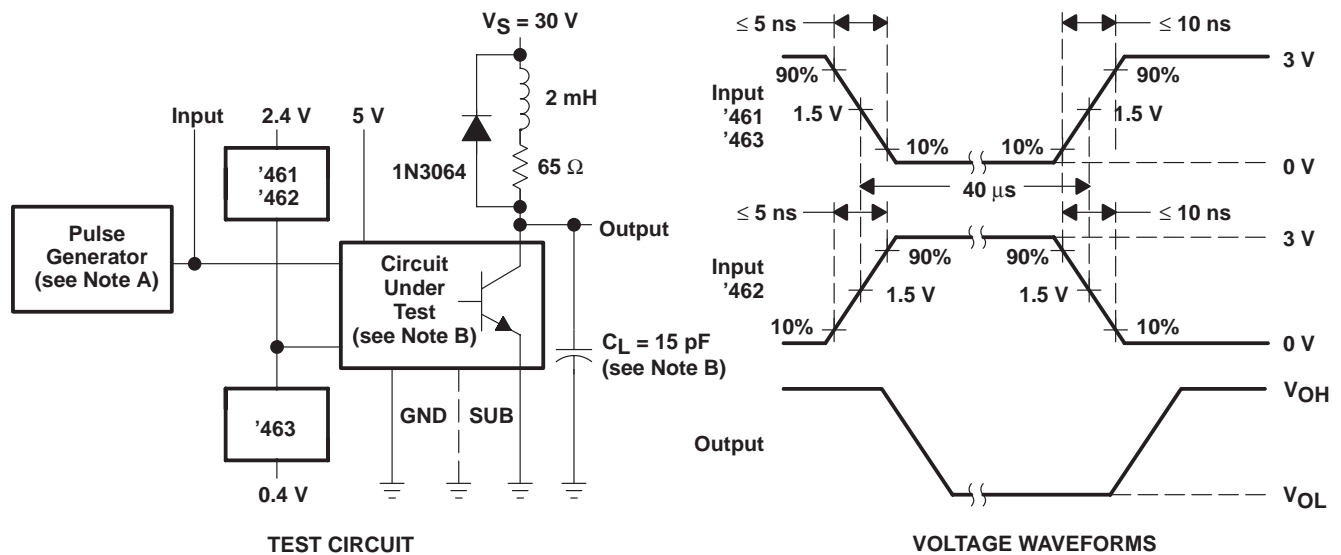

- NOTES: A. The pulse generator has the following characteristics: PRR \leq 12.5 kHz, $Z_O = 50 \Omega$.
 B. C_L includes probe and jig capacitance.

Figure 2. Test Circuit and Voltage Waveforms for Latch-Up Test

PACKAGING INFORMATION

Orderable part number	Status (1)	Material type (2)	Package Pins	Package qty Carrier	RoHS (3)	Lead finish/ Ball material (4)	MSL rating/ Peak reflow (5)	Op temp (°C)	Part marking (6)
JM38510/12908BPA	Active	Production	CDIP (JG) 8	50 TUBE	No	SNPB	N/A for Pkg Type	-55 to 125	JM38510 /12908BPA
JM38510/12908BPA.A	Active	Production	CDIP (JG) 8	50 TUBE	No	SNPB	N/A for Pkg Type	-55 to 125	JM38510 /12908BPA
M38510/12908BPA	Active	Production	CDIP (JG) 8	50 TUBE	No	SNPB	N/A for Pkg Type	-55 to 125	JM38510 /12908BPA
SN75462D	Active	Production	SOIC (D) 8	75 TUBE	Yes	NIPDAU	Level-1-260C-UNLIM	0 to 70	75462
SN75462D.A	Active	Production	SOIC (D) 8	75 TUBE	Yes	NIPDAU	Level-1-260C-UNLIM	0 to 70	75462
SN75462DR	Active	Production	SOIC (D) 8	2500 LARGE T&R	Yes	NIPDAU	Level-1-260C-UNLIM	0 to 70	75462
SN75462DR.A	Active	Production	SOIC (D) 8	2500 LARGE T&R	Yes	NIPDAU	Level-1-260C-UNLIM	0 to 70	75462
SN75462P	Active	Production	PDIP (P) 8	50 TUBE	Yes	NIPDAU	N/A for Pkg Type	0 to 70	SN75462P
SN75462P.A	Active	Production	PDIP (P) 8	50 TUBE	Yes	NIPDAU	N/A for Pkg Type	0 to 70	SN75462P
SN75462PE4	Active	Production	PDIP (P) 8	50 TUBE	Yes	NIPDAU	N/A for Pkg Type	0 to 70	SN75462P
SN75463P	Active	Production	PDIP (P) 8	50 TUBE	Yes	NIPDAU	N/A for Pkg Type	0 to 70	SN75463P
SN75463P.A	Active	Production	PDIP (P) 8	50 TUBE	Yes	NIPDAU	N/A for Pkg Type	0 to 70	SN75463P
SNJ55462FK	Active	Production	LCCC (FK) 20	55 TUBE	No	SNPB	N/A for Pkg Type	-55 to 125	SNJ55 462FK
SNJ55462FK.A	Active	Production	LCCC (FK) 20	55 TUBE	No	SNPB	N/A for Pkg Type	-55 to 125	SNJ55 462FK
SNJ55462JG	Active	Production	CDIP (JG) 8	50 TUBE	No	SNPB	N/A for Pkg Type	-55 to 125	SNJ55462JG
SNJ55462JG.A	Active	Production	CDIP (JG) 8	50 TUBE	No	SNPB	N/A for Pkg Type	-55 to 125	SNJ55462JG

(1) **Status:** For more details on status, see our [product life cycle](#).

(2) **Material type:** When designated, preproduction parts are prototypes/experimental devices, and are not yet approved or released for full production. Testing and final process, including without limitation quality assurance, reliability performance testing, and/or process qualification, may not yet be complete, and this item is subject to further changes or possible discontinuation. If available for ordering, purchases will be subject to an additional waiver at checkout, and are intended for early internal evaluation purposes only. These items are sold without warranties of any kind.

(3) **RoHS values:** Yes, No, RoHS Exempt. See the [TI RoHS Statement](#) for additional information and value definition.

(4) **Lead finish/Ball material:** Parts may have multiple material finish options. Finish options are separated by a vertical ruled line. Lead finish/Ball material values may wrap to two lines if the finish value exceeds the maximum column width.

⁽⁵⁾ **MSL rating/Peak reflow:** The moisture sensitivity level ratings and peak solder (reflow) temperatures. In the event that a part has multiple moisture sensitivity ratings, only the lowest level per JEDEC standards is shown. Refer to the shipping label for the actual reflow temperature that will be used to mount the part to the printed circuit board.

⁽⁶⁾ **Part marking:** There may be an additional marking, which relates to the logo, the lot trace code information, or the environmental category of the part.

Multiple part markings will be inside parentheses. Only one part marking contained in parentheses and separated by a "~" will appear on a part. If a line is indented then it is a continuation of the previous line and the two combined represent the entire part marking for that device.

Important Information and Disclaimer: The information provided on this page represents TI's knowledge and belief as of the date that it is provided. TI bases its knowledge and belief on information provided by third parties, and makes no representation or warranty as to the accuracy of such information. Efforts are underway to better integrate information from third parties. TI has taken and continues to take reasonable steps to provide representative and accurate information but may not have conducted destructive testing or chemical analysis on incoming materials and chemicals. TI and TI suppliers consider certain information to be proprietary, and thus CAS numbers and other limited information may not be available for release.

In no event shall TI's liability arising out of such information exceed the total purchase price of the TI part(s) at issue in this document sold by TI to Customer on an annual basis.

OTHER QUALIFIED VERSIONS OF SN55462, SN75462 :

- Catalog : [SN75462](#)
- Military : [SN55462](#)

NOTE: Qualified Version Definitions:

- Catalog - TI's standard catalog product
- Military - QML certified for Military and Defense Applications

TAPE AND REEL INFORMATION

QUADRANT ASSIGNMENTS FOR PIN 1 ORIENTATION IN TAPE

*All dimensions are nominal

Device	Package Type	Package Drawing	Pins	SPQ	Reel Diameter (mm)	Reel Width W1 (mm)	A0 (mm)	B0 (mm)	K0 (mm)	P1 (mm)	W (mm)	Pin1 Quadrant
SN75462DR	SOIC	D	8	2500	330.0	12.4	6.4	5.2	2.1	8.0	12.0	Q1

TAPE AND REEL BOX DIMENSIONS

*All dimensions are nominal

Device	Package Type	Package Drawing	Pins	SPQ	Length (mm)	Width (mm)	Height (mm)
SN75462DR	SOIC	D	8	2500	353.0	353.0	32.0

TUBE

*All dimensions are nominal

Device	Package Name	Package Type	Pins	SPQ	L (mm)	W (mm)	T (μm)	B (mm)
SN75462D	D	SOIC	8	75	507	8	3940	4.32
SN75462D.A	D	SOIC	8	75	507	8	3940	4.32
SN75462P	P	PDIP	8	50	506	13.97	11230	4.32
SN75462P.A	P	PDIP	8	50	506	13.97	11230	4.32
SN75462PE4	P	PDIP	8	50	506	13.97	11230	4.32
SN75463P	P	PDIP	8	50	506	13.97	11230	4.32
SN75463P.A	P	PDIP	8	50	506	13.97	11230	4.32
SNJ55462FK	FK	LCCC	20	55	506.98	12.06	2030	NA
SNJ55462FK.A	FK	LCCC	20	55	506.98	12.06	2030	NA

GENERIC PACKAGE VIEW

FK 20

LCCC - 2.03 mm max height

8.89 x 8.89, 1.27 mm pitch

LEADLESS CERAMIC CHIP CARRIER

This image is a representation of the package family, actual package may vary.
Refer to the product data sheet for package details.



4229370VA\



D0008A

PACKAGE OUTLINE

SOIC - 1.75 mm max height

SMALL OUTLINE INTEGRATED CIRCUIT



4214825/C 02/2019

NOTES:

1. Linear dimensions are in inches [millimeters]. Dimensions in parenthesis are for reference only. Controlling dimensions are in inches. Dimensioning and tolerancing per ASME Y14.5M.
2. This drawing is subject to change without notice.
3. This dimension does not include mold flash, protrusions, or gate burrs. Mold flash, protrusions, or gate burrs shall not exceed $.006$ [0.15] per side.
4. This dimension does not include interlead flash.
5. Reference JEDEC registration MS-012, variation AA.

EXAMPLE BOARD LAYOUT

D0008A

SOIC - 1.75 mm max height

SMALL OUTLINE INTEGRATED CIRCUIT



LAND PATTERN EXAMPLE
 EXPOSED METAL SHOWN
 SCALE:8X



SOLDER MASK DETAILS

4214825/C 02/2019

NOTES: (continued)

- 6. Publication IPC-7351 may have alternate designs.
- 7. Solder mask tolerances between and around signal pads can vary based on board fabrication site.

EXAMPLE STENCIL DESIGN

D0008A

SOIC - 1.75 mm max height

SMALL OUTLINE INTEGRATED CIRCUIT



SOLDER PASTE EXAMPLE
BASED ON .005 INCH [0.125 MM] THICK STENCIL
SCALE:8X

4214825/C 02/2019

NOTES: (continued)

8. Laser cutting apertures with trapezoidal walls and rounded corners may offer better paste release. IPC-7525 may have alternate design recommendations.
9. Board assembly site may have different recommendations for stencil design.

P (R-PDIP-T8)

PLASTIC DUAL-IN-LINE PACKAGE



- NOTES:
- A. All linear dimensions are in inches (millimeters).
 - B. This drawing is subject to change without notice.
 - C. Falls within JEDEC MS-001 variation BA.

PACKAGE OUTLINE

JG0008A

CDIP - 5.08 mm max height

CERAMIC DUAL IN-LINE PACKAGE

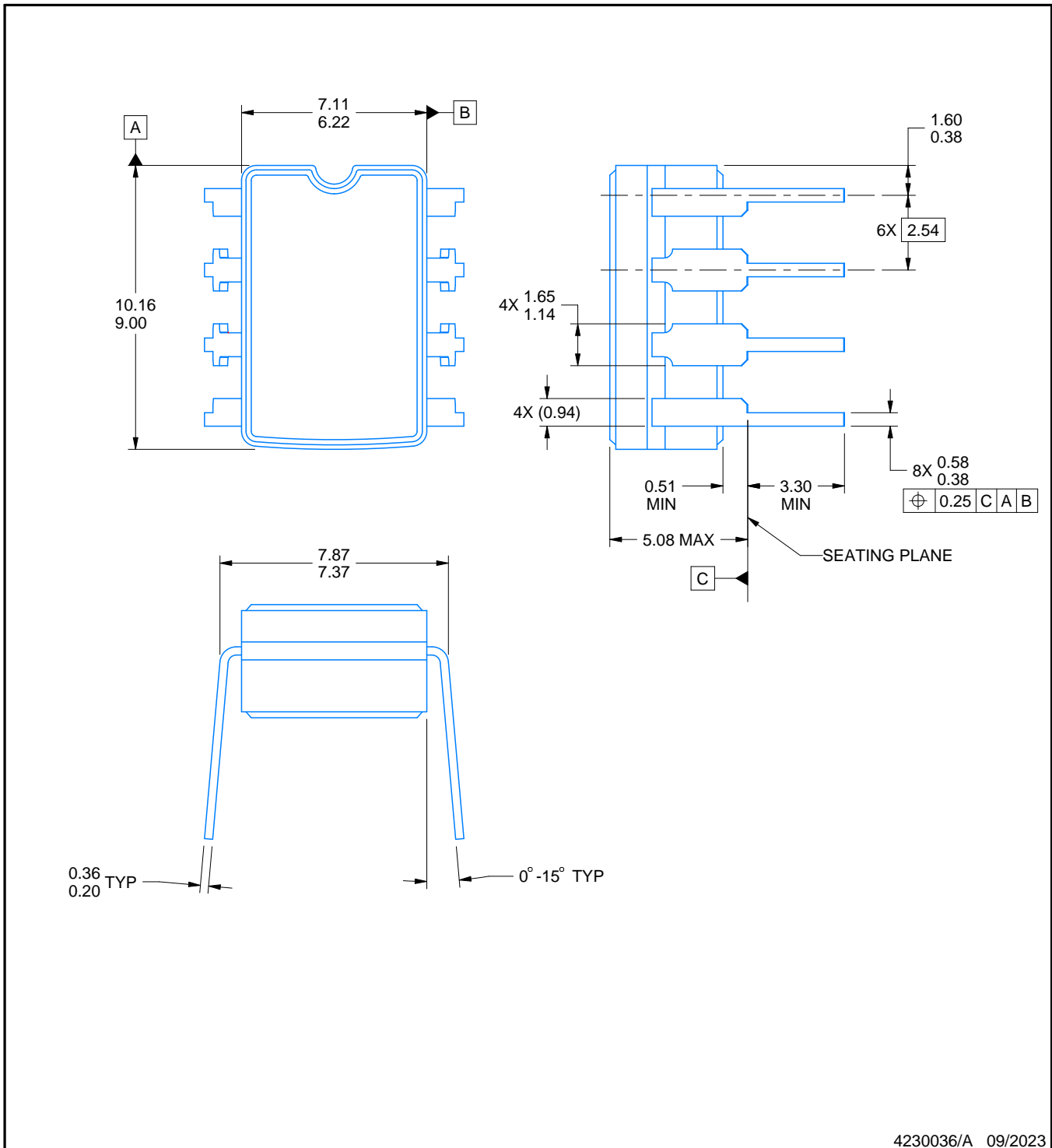

NOTES:

1. All linear dimensions are in millimeters. Any dimensions in parenthesis are for reference only. Dimensioning and tolerancing per ASME Y14.5M.
2. This drawing is subject to change without notice.
3. This package can be hermetically sealed with a ceramic lid using glass frit.
4. Index point is provided on cap for terminal identification.
5. Falls within MIL STD 1835 GDIP1-T8

EXAMPLE BOARD LAYOUT

JG0008A

CDIP - 5.08 mm max height

CERAMIC DUAL IN-LINE PACKAGE

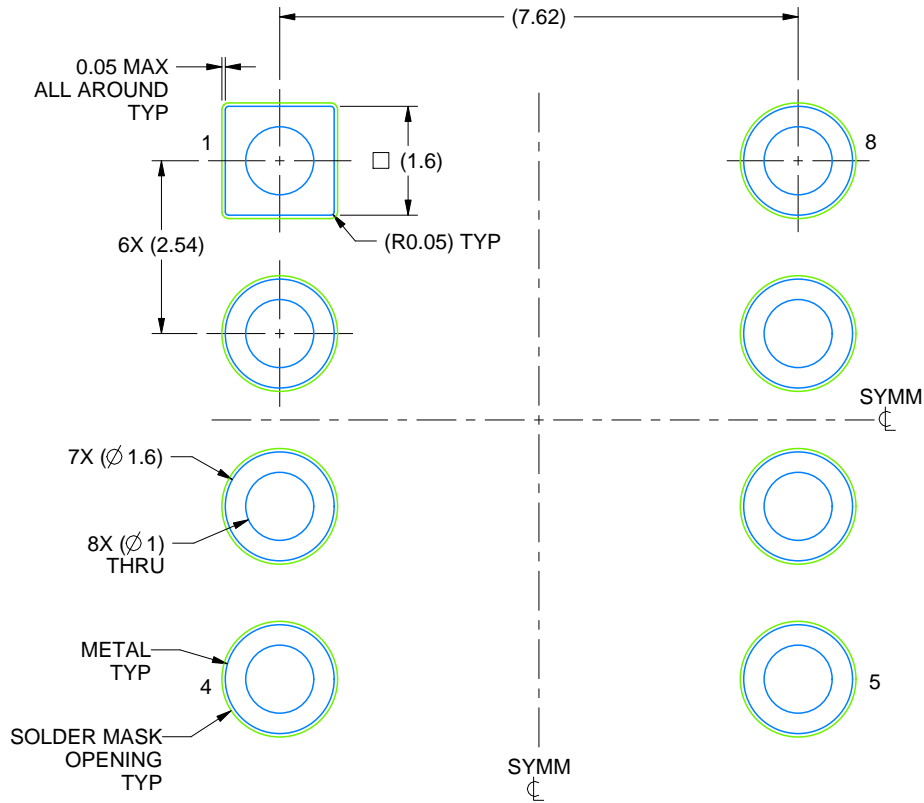

LAND PATTERN EXAMPLE
NON SOLDER MASK DEFINED
SCALE: 9X

4230036/A 09/2023

IMPORTANT NOTICE AND DISCLAIMER

TI PROVIDES TECHNICAL AND RELIABILITY DATA (INCLUDING DATA SHEETS), DESIGN RESOURCES (INCLUDING REFERENCE DESIGNS), APPLICATION OR OTHER DESIGN ADVICE, WEB TOOLS, SAFETY INFORMATION, AND OTHER RESOURCES "AS IS" AND WITH ALL FAULTS, AND DISCLAIMS ALL WARRANTIES, EXPRESS AND IMPLIED, INCLUDING WITHOUT LIMITATION ANY IMPLIED WARRANTIES OF MERCHANTABILITY, FITNESS FOR A PARTICULAR PURPOSE OR NON-INFRINGEMENT OF THIRD PARTY INTELLECTUAL PROPERTY RIGHTS.

These resources are intended for skilled developers designing with TI products. You are solely responsible for (1) selecting the appropriate TI products for your application, (2) designing, validating and testing your application, and (3) ensuring your application meets applicable standards, and any other safety, security, regulatory or other requirements.

These resources are subject to change without notice. TI grants you permission to use these resources only for development of an application that uses the TI products described in the resource. Other reproduction and display of these resources is prohibited. No license is granted to any other TI intellectual property right or to any third party intellectual property right. TI disclaims responsibility for, and you will fully indemnify TI and its representatives against, any claims, damages, costs, losses, and liabilities arising out of your use of these resources.

TI's products are provided subject to [TI's Terms of Sale](#) or other applicable terms available either on [ti.com](https://www.ti.com) or provided in conjunction with such TI products. TI's provision of these resources does not expand or otherwise alter TI's applicable warranties or warranty disclaimers for TI products.

TI objects to and rejects any additional or different terms you may have proposed.

Mailing Address: Texas Instruments, Post Office Box 655303, Dallas, Texas 75265

Copyright © 2025, Texas Instruments Incorporated