

# TMDS1204 12Gbps, DC or AC-Coupled to TMDS® and FRL HDMI™ Hybrid Redriver

## 1 Features

- AC-coupled or DC-coupled input and output supporting HDMI 2.1 data rates up to 12Gbps
  - Backwards compatible to HDMI 1.4b and HDMI 2.0b
  - HDMI 2.1 fixed rate link (FRL) of 3, 6, 8, 10, and 12Gbps
  - Supports HDMI 2.1 three and four lane FRL
- Optimized for HDMI sink applications
- Adaptive and fixed equalizer up to 12dB at 6GHz
- I<sup>2</sup>C or pin strap programmable
- Integrated HPD level shifter supporting both 1.8V and 3.3V LVCMOS levels
- Full lane swap on main lanes
- Integrated fan-out buffer for applications which require separate clock and data paths
- Signal detect output indicator
- Digital display control (DDC) snooping function for link configuration
- Low power consumption:
  - 12G FRL four lanes active limited: 575mW
  - 12 G FRL four lanes active linear: 220mW
  - Power down: 0.6mW
- Available in commercial and industrial temperature
- Single 3.3V power supply
- 40-pin, 0.4mm pitch, 4mm × 6mm, WQFN package

## 2 Applications

- [Notebooks and desktops](#)
- [TV](#)
- [Home theater and entertainment](#)
- [Gaming systems](#)
- [Docking stations](#)
- [Pro audio, video, and signage](#)

## 3 Description

The TMDS1204 is an HDMI 2.1 redriver supporting data rates up to 12Gbps. It is backwards compatible for HDMI 1.4b and HDMI 2.0b. The high-speed differential inputs and outputs can either be AC-coupled or DC-coupled, which qualifies the TMDS1204 to be used as a DP++ to HDMI level shifter or HDMI redriver. The TMDS1204 can support both 3 and 4 lane HDMI 2.1 FRL at 3, 6, 8, 10, and 12Gbps.

The TMDS1204 is a hybrid redriver supporting both source and sink applications. A hybrid redriver can operate either in a linear or limited redriver function. When configured as a limited redriver, the TMDS1204 differential output voltage levels are independent of the graphics process unit (GPU) output levels ensuring HDMI compliant levels at the receptacle. The limited redriver mode is recommended for HDMI source applications. When configured as a linear redriver, the TMDS1204 differential output levels are a linear function of the GPU output levels enabling TMDS1204 to be transparent to link training and operate as a channel shortener. Linear redriver mode is recommended for HDMI sink applications.

The TMDS1204 has an integrated HPD level shifter. The HPD level shifter will shift the 5V HPD signal to either 1.8V or 3.3V. The level shifter output can also be configured for push, pull, or open-drain. The integration of the level shifter eliminates discrete solutions and thereby saves system cost.

The TMDS1204 supports single power supply rails of 3.3V on V<sub>CC</sub> and is offered in a commercial temperature (TMDS1204) and industrial temperature (TMDS1204I).

### Device Information

PART NUMBER <sup>(1)</sup>	TEMPERATURE	PACKAGE
TMDS1204	Ta = 0°C to 70°C	RNQ (WQFN, 40)
TMDS1204I	Ta = -40°C to 85°C	

(1) For more information, see [Section 11](#).

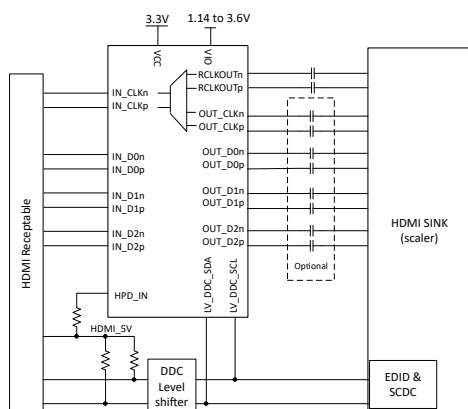

**Simplified Schematic**



## Table of Contents

<b>1 Features</b> .....	1	7.4 Programming.....	39
<b>2 Applications</b> .....	1	7.5 Register Maps.....	43
<b>3 Description</b> .....	1	<b>8 Application and Implementation</b> .....	56
<b>4 Pin Configuration and Functions</b> .....	3	8.1 Application Information.....	56
<b>5 Specifications</b> .....	6	8.2 Typical Source-Side Application.....	56
5.1 Absolute Maximum Ratings.....	6	8.3 Typical Sink-Side Application.....	61
5.2 ESD and Latch-Up Ratings.....	6	8.4 Power Supply Recommendations.....	64
5.3 Recommended Operating Conditions.....	6	8.5 Layout.....	65
5.4 Thermal Information.....	7	<b>9 Device and Documentation Support</b> .....	67
5.5 Electrical Characteristics.....	7	9.1 Documentation Support.....	67
5.6 Timing Requirements.....	13	9.2 Receiving Notification of Documentation Updates...	67
5.7 Switching Characteristics.....	14	9.3 Support Resources.....	67
5.8 Typical Characteristics.....	17	9.4 Trademarks.....	67
<b>6 Parameter Measurement Information</b> .....	18	9.5 Electrostatic Discharge Caution.....	67
<b>7 Detailed Description</b> .....	23	9.6 Glossary.....	67
7.1 Functional Block Diagram .....	23	<b>10 Revision History</b> .....	67
7.2 Feature Description.....	24	<b>11 Mechanical, Packaging, and Orderable Information</b> .....	67
7.3 Device Functional Modes.....	35		

## 4 Pin Configuration and Functions

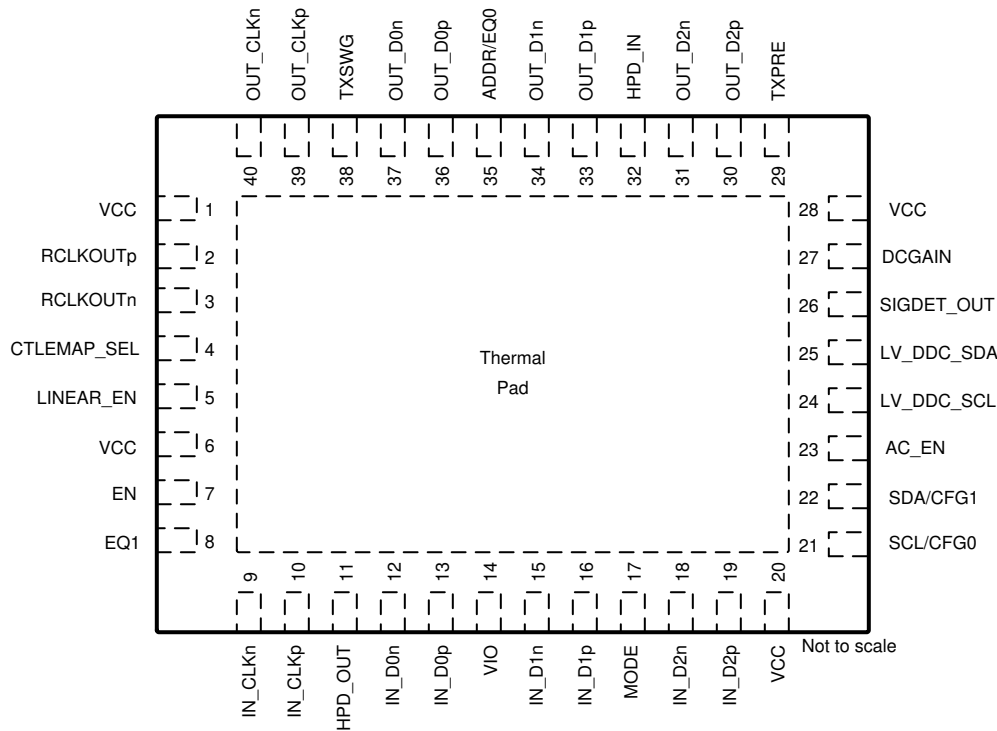

Figure 4-1. RNQ Package, 40-Pin WQFN (Top View)

Table 4-1. Pin Functions

PIN		TYPE <sup>(1)</sup>	DESCRIPTION
NAME	NO.		
VCC	1	P	3.3V power supply
RCLKOUTp	2	O	HDMI 1.4/2.0 clock differential positive output when not operating in HDMI 2.1 FRL mode with Fan-out buffer feature enabled. External AC coupling required. If not used, then this pin can be left unconnected.
RCLKOUTn	3	O	HDMI 1.4/2.0 clock differential negative output when not operating in HDM I2.1 FRL mode with Fan-out buffer feature enabled. External AC coupling required. If not used, then this pin can be left unconnected.
CTLEMAP_SEL	4	I 4 Level (PU/PD)	CTLE Map select. When TMDS1204 is configured in pin-strap mode, this pin selects the CTLE Map used. <a href="#">Table 7-8</a> provides more details. Also in pin-strap this pin will control whether or not AEQ is enabled. <a href="#">Table 7-9</a> provides more details. In I <sup>2</sup> C mode, CTLE Map and AEQ enable is determined by registers.
LINEAR_EN	5	I 4-Level (PU/PD)	In pin-strap mode, selects whether TMDS1204 operates in linear or limited redriver mode. <a href="#">Table 7-5</a> provides more details.
VCC	6	P	3.3V power supply
EN	7	I 2-Level (PU)	When low, TMDS1204 will be held in reset. The IN_D[2:0], IN_CLK, OUT_D[2:0] and OUT_CLK pins will be held in high impedance while EN is low. On rising edge of EN, device will sample four-level inputs and function based on the sampled state of the pins. This pin has a internal 250 k pull-up to VIO.

**Table 4-1. Pin Functions (continued)**

PIN		TYPE <sup>(1)</sup>	DESCRIPTION
NAME	NO.		
EQ1	8	I 4 Level (PU/PD)	EQ1 Pin Setting when TMDS1204 is configured for pin strap mode; Works in conjunction with EQ0; <a href="#">Table 7-6</a> provides the settings. In I <sup>2</sup> C mode, EQ settings are controlled through registers.
IN_CLKn	9	I	Clock differential negative input.
IN_CLKp	10	I	Clock differential positive input.
HPD_OUT	11	O	Hot plug detect output to source side. If not used, then this pin can be left floating.
IN_D0n	12	I	Channel 0 differential negative input.
IN_D0p	13	I	Channel 0 differential positive input.
VIO	14	P	Voltage supply for I/Os. <a href="#">Table 7-2</a> provides more information.
IN_D1n	15	I	Channel 1 differential negative input.
IN_D1p	16	I	Channel 1 differential positive input.
MODE	17	I 4 Level (PU/PD)	Mode control pin. Selects between pin-strap and I <sup>2</sup> C mode. For more information, refer to <a href="#">Section 7.3.1</a> .
IN_D2n	18	I	Channel 2 differential negative input.
IN_D2p	19	I	Channel 2 differential positive input.
VCC	20	P	3.3V power supply.
SCL/CFG0	21	I	I <sup>2</sup> C Clock/CFG0: when TMDS1204 is configured for I <sup>2</sup> C mode, this pin will function as the I <sup>2</sup> C clock. Otherwise, this pin will function as CFG0. <a href="#">Table 7-18</a> provides more details.
SDA/CFG1	22	I/O	I <sup>2</sup> C Data / CFG1: When TMDS1204 is configured for I <sup>2</sup> C mode, this pin will function as the I <sup>2</sup> C clock. Otherwise, this pin will function as CFG1. <a href="#">Table 7-19</a> provides more details.
AC_EN	23	I 2-Level (PD)	In pin-strap mode, selects whether high speed transmitters are externally AC or DC coupled. 0: DC-coupled 1: AC-coupled
LV_DDC_SCL	24	I/O	Low voltage side DDC clock line. Internally pulled-up to VIO.
LV_DDC_SDA	25	I/O	Low voltage side DDC data line. Internally pulled-up to VIO.
SIGDET_OUT	26	O	SIGDET_OUT. Open drain output asserted low when signal is detected on IN_CLK or IN_D2 when HPD_IN is high. Otherwise signal is de-asserted. When used requires 10k or greater pull-up resistor.
DCGAIN	27	I 4 Level (PU/PD)	DC Gain. "0": -3dB "R": -3dB "F": 0dB "1": +1dB
VCC	28	P	3.3V power supply
TXPRE	29	I 4 Level (PU/PD)	TX pre-emphasis control: in pin-strap mode with limited enabled, this pin controls TX EQ. In pin-strap with linear and AEQ enabled, this pin will adjust the adapted value. <a href="#">Table 7-15</a> provides the available TXPRE settings when operating in pin strap mode. In I <sup>2</sup> C mode, Tx pre-emphasis is controlled through registers.
OUT_D2p	30	O	TMDS data 2 differential positive output
OUT_D2n	31	O	TMDS data 2 differential negative output
HPD_IN	32	I 2-Level (PD)	Hot plug detect input from sink side. This pin has an internal pull-down resistor and is fail-safe.
OUT_D1p	33	O	TMDS data 1 differential positive output
OUT_D1n	34	O	TMDS data 1 differential negative output
ADDR/EQ0	35	I 4 Level (PU/PD)	Address bit for I <sup>2</sup> C programming when TMDS1204 is configured for I <sup>2</sup> C mode. <a href="#">Table 7-22</a> provides more details. EQ0 pin setting when TMDS1204 is configured for pin strap mode; works in conjunction with EQ1; <a href="#">Table 7-6</a> lists the settings. In I <sup>2</sup> C mode, EQ settings are controlled through registers.

**Table 4-1. Pin Functions (continued)**

PIN		TYPE <sup>(1)</sup>	DESCRIPTION
NAME	NO.		
OUT_D0p	36	O	TMDS data 0 differential positive output
OUT_D0n	37	O	TMDS data 0 differential negative output
TXSWG	38	I 4 Level (PU/PD)	TX output swing control: 4 settings. This pin is only used in pin strap mode. <a href="#">Table 7-17</a> provides the available TX swing settings. In I <sup>2</sup> C mode, TX output swing is controlled through registers.
OUT_CLKp	39	O	TMDS data clock differential positive output
OUT_CLKn	40	O	TMDS data clock differential negative output
Thermal Pad		—	Thermal pad. Connect to a solid ground plane.

(1) I = input, O = output, P = power, G = ground

## 5 Specifications

### 5.1 Absolute Maximum Ratings

over operating free-air temperature range (unless otherwise noted)<sup>(1)</sup>

		MIN	MAX	UNIT
Supply Voltage	V <sub>CC</sub> and V <sub>IO</sub>	-0.5	4	V
Input Voltage	Differential Inputs (IN_D[2:0], IN_CLK)	-0.3	4	V
Output voltage	RCLKOUTp/n, HPD_OUT, SIGDET_OUT outputs	-0.3	4	V
Output voltage	Differential outputs (OUT_D[2:0], OUT_CLK)	-0.3	4	V
Control pins	LV_DDC_SDA, LV_DDC_SCL, SCL/CFG0, SDA/CFG1, MODE, CLTEMAP_SEL, TXSWG, TXPRE, EQ1, ADDR/EQ0, EN, AC_EN, LINEAR_EN, DCGAIN	-0.5	4	V
	HPD_IN	-0.5	6	V
T <sub>J</sub>	TMDS1204 Junction temperature		105	°C
T <sub>J</sub>	TMDS1204I Junction temperature		125	°C
T <sub>stg</sub>	Storage temperature	-65	150	°C

- (1) Operation outside the *Absolute Maximum Rating* may cause permanent damage to the device. Absolute maximum ratings do not imply functional operation of the device at these or any other conditions beyond those listed under the *Recommended Operating Condition*. If briefly operating outside the *Recommended Operating Conditions* but within the *Absolute Maximum Ratings*, the device may not sustain damage, but it may not be fully functional. Operating the device in this manner may affect device reliability, functionality, performance, and shorten the device lifetime.

### 5.2 ESD and Latch-Up Ratings

			VALUE	UNIT
V <sub>(ESD)</sub>	Electrostatic discharge	Human-body model (HBM), per ANSI/ESDA/JEDEC JS-001 <sup>(1)</sup>	±4000	V
		Charged-device model (CDM), per JEDEC specification JS-002 <sup>(2)</sup>	±1500	
V <sub>(Supply)</sub>	Supply Test	Supply test, per JESD78F class II <sup>(3)</sup>	1.5 x V <sub>CC</sub>	V
I <sub>(signal+)</sub>	Positive signal pin latch-up	Signal pin test, per JESD78F class II, immunity level A (all signal pins) <sup>(3)</sup>	+100	mA
I <sub>(signal-)</sub>	Negative signal pin latch-up	Signal pin test, per JESD78F class II, immunity level A (all signal pins except pin 2 and pin 3) <sup>(3)</sup>	-100	mA
		Signal pin test, per JESD78F class II, immunity level B, annex A flow 1F (pin 2 and pin 3 are connected through 10 nF capacitors) <sup>(3)(4)</sup>	-100	mA

- (1) JEDEC document JEP155 states that 500-V HBM allows safe manufacturing with a standard ESD control process. .  
 (2) JEDEC document JEP157 states that 250-V CDM allows safe manufacturing with a standard ESD control process.  
 (3) JESD78F at maximum ambient temperature  
 (4) Per annex A flow 1F, negative pulse immunity on pin 2 and pin 3 is -15 mA without 10 nF series capacitors. Care should be given during ICT to limit test current to less than -15 mA.

### 5.3 Recommended Operating Conditions

over operating free-air temperature range (unless otherwise noted)

		MIN	NOM	MAX	UNIT
V <sub>CC</sub>	Supply voltage when high-speed RX pins (IN_D[2:0] and IN_CLK) is AC-coupled to a DP++ TX	3.0	3.3	3.6	V
V <sub>CC</sub>	Supply voltage when high-speed RX pins (IN_D[2:0] and IN_CLK) is DC-coupled to a HDMI TX	3.135	3.3	3.465	V
V <sub>IO</sub>	VIO supply when 1.2V LVCMOS level used.	1.14	1.2	1.26	V
V <sub>IO</sub>	VIO supply when 1.8V LVCMOS level used.	1.7	1.8	1.9	V
V <sub>IO</sub>	VIO supply when 3.3V LVCMOS level used.	3	3.3	3.6	V
V <sub>PSN</sub>	Peak to peak Power supply noise on V <sub>CC</sub> pins (less than 4MHz).			100	mV
V <sub>CTL3</sub>	DC input voltage for SCL/CFG0, SDA/CFG1, MODE, AC_EN, LINEAR_EN, EN, CTLEMAP_SEL, TXSWG, TXPRE, EQ1, ADDR1/EQ0, DCGAIN, LV_DDC_SCL, LV_DDC_SDA	-0.3		3.6	V

### 5.3 Recommended Operating Conditions (continued)

over operating free-air temperature range (unless otherwise noted)

		MIN	NOM	MAX	UNIT
V <sub>CTL5</sub>	DC input voltage for HPD_IN pins	-0.3		5.5	V
C <sub>ACRX</sub>	Optional external AC-coupling capacitor on IN_Dx and IN_CLK.	85		253	nF
C <sub>ACTX</sub>	External AC-coupling capacitor on OUT_Dx and OUT_CLK when AC_EN = H.	85		253	nF
T <sub>A</sub>	TMDS1204 Ambient temperature	0		70	°C
T <sub>A</sub>	TMDS1204I Ambient temperature	-40		85	°C

### 5.4 Thermal Information

THERMAL METRIC <sup>(1)</sup>		TMDS1204	UNIT
		RNQ (WQFN)	
		40 PINS	
R <sub>θJA</sub>	Junction-to-ambient thermal resistance	30.9	°C/W
R <sub>θJC(top)</sub>	Junction-to-case (top) thermal resistance	21.2	°C/W
R <sub>θJB</sub>	Junction-to-board thermal resistance	11.7	°C/W
Ψ <sub>JT</sub>	Junction-to-top characterization parameter	0.3	°C/W
Ψ <sub>JB</sub>	Junction-to-board characterization parameter	11.7	°C/W
R <sub>θJC(bot)</sub>	Junction-to-case (bottom) thermal resistance	3.8	°C/W

(1) For more information about traditional and new thermal metrics, see the [Semiconductor and IC Package Thermal Metrics](#) application report.

### 5.5 Electrical Characteristics

over recommended voltage and operating free-air temperature range (unless otherwise noted)

PARAMETER		TEST CONDITIONS	MIN	TYP	MAX	UNIT
<b>POWER</b>						
P <sub>ACTIVE-H14-LT-ARX-DTX</sub>	Power dissipation in HDMI 1.4 3.4Gbps active operation	Pin Strap mode; DR = 3.4Gbps; HPD_IN = H; No de-emphasis/pre-emphasis; Limited redriver mode; DC-coupled TX; AC-coupled RX; 3Gbps CTLE;		190	265	mW
P <sub>ACTIVE-H20-LT-ARX-DTX</sub>	Power dissipation in HDMI 2.0 6Gbps active operation	Pin Strap mode; DR = 6Gbps; HPD_IN = H; No de-emphasis/pre-emphasis; Limited redriver mode; DC-coupled TX; AC-coupled RX; 6Gbps CTLE;		215	305	mW
P <sub>ACTIVE-FRL-LT-DRX-DTX</sub>	Power dissipation in FRL 12Gbps active operation when TX is DC-coupled (AC_EN = L) and RX is DC-coupled;	Pin Strap mode; DR = 12Gbps; HPD_IN = H; TXFFE0; Limited redriver mode; DC-coupled TX; DC-coupled RX to 3.3V V <sub>icm</sub> ; 12Gbps CTLE;		540	775	mW
P <sub>ACTIVE-FRL-LT-ARX-ATX</sub>	Power dissipation in FRL 12Gbps active operation when TX is AC-coupled (AC_EN = H)	Pin Strap mode; DR = 12Gbps; HPD_IN = H; TXFFE0; Limited redriver mode; AC-coupled TX; AC-coupled RX; 12Gbps CTLE;		840	1220	mW
P <sub>ACTIVE-FRL-LT-ARX-DTX</sub>	Power dissipation in FRL 12Gbps active operation when TX is DC-coupled (AC_EN = L)	Pin Strap mode; DR = 12Gbps; HPD_IN = H; TXFFE0; Limited redriver mode; DC-coupled TX; AC-coupled RX; 12Gbps CTLE;		575	785	mW
P <sub>ACTIVE-FRL-LR-ARX-DTX</sub>	Power dissipation in FRL 12Gbps active operation when TX is DC-coupled (AC_EN = L)	Pin Strap mode; DR = 12Gbps; HPD_IN = H; Highest linearity setting; Linear redriver mode; DC-coupled TX; AC-coupled RX; 12Gbps CTLE;		220	310	mW

## 5.5 Electrical Characteristics (continued)

over recommended voltage and operating free-air temperature range (unless otherwise noted)

PARAMETER		TEST CONDITIONS	MIN	TYP	MAX	UNIT
P <sub>ACTIVE-FRL-LR-ARX-ATX</sub>	Power dissipation in FRL 12Gbps active operation when TX is AC-coupled (AC_EN = H)	Pin Strap mode; DR = 12Gbps; HPD_IN = H; Highest linearity setting; Linear redriver mode; AC-coupled TX; AC-coupled RX; 12Gbps CTLE		660	990	mW
P <sub>PD</sub>	Power in power-down (HPD_IN = L)	Pin Strap mode; HPD_IN = L; EN = L or H; High-speed outputs are disconnected;		0.6	2	mW
P <sub>SD</sub>	Power in standby (HPD_IN = H) but no incoming signal	Pin Strap mode; HPD_IN = H; No incoming signal; EN = H; DC-coupled TX; AC-coupled RX; Limited redriver mode; High-speed outputs are connected;		1.0	1.85	mW
I <sub>VIOQ</sub>	VIO quiescent current	HPD_IN = H; VCC = VIO = 3.6V; LV_DDC_SDA/SCL = H;			16	μA
I <sub>VIOA</sub>	VIO active instantaneous current	VCC = VIO = 3.6V; HPD_IN = H;			1	mA
<b>2-LEVEL CONTROL PINS (EN, SCL/CFG0, SDA/CFG1, AC_EN)</b>						
V <sub>IO_TRSH D</sub>	Threshold for selecting between 1.2V LVCMOS / 1.8V LVCMOS			1.5		V
V <sub>IO_TRSH D</sub>	Threshold for selecting between 1.8V LVCMOS / 3.3V LVCMOS			2.5		V
V <sub>IL_1p2V</sub>	Low-level input voltage for SCL/CFG0, SDA/CFG1	VIO = 1.26V; VCC = 3.0V;	-0.3		0.360	V
V <sub>IH_1p2V</sub>	High-level input voltage for SCL/CFG0, SDA/CFG1	VIO = 1.14V; VCC = 3.6V;	0.8		3.6	V
V <sub>IL_1p8V</sub>	Low-level input voltage for SCL/CFG0, SDA/CFG1	VIO = 1.9V; VCC = 3.0V;	-0.3		0.57	V
V <sub>IH_1p8V</sub>	High-level input voltage for SCL/CFG0, SDA/CFG1	VIO = 1.7V; VCC = 3.6V;	1.19		3.6	V
V <sub>IL_3p3V</sub>	Low-level input voltage for SCL/CFG0, SDA/CFG1	VIO = 3.6V; VCC = 3.0V;	-0.3		0.8	V
V <sub>IL_3p3V</sub>	Low-level input voltage for AC_EN	VIO = 3.6V; VCC = 3.0V;	-0.3		0.8	V
V <sub>IH_3p3V</sub>	High-level input voltage for SCL/CFG0, SDA/CFG1	VIO = 3.0V; VCC = 3.6V;	2.2		3.6	V
V <sub>IH_3p3V</sub>	High-level input voltage for AC_EN	VIO = 3.0V; VCC = 3.6V;	2.2		3.6	V
V <sub>OL_1p2V</sub>	Low-level output voltage SDA/CFG1	V <sub>CC</sub> = 3.0V; VIO = 1.2V;	-0.3		0.3	V
I <sub>OL_1p2V</sub>	Low-level output current SDA/CFG1	V <sub>CC</sub> = 3.0V; VIO = 1.2V;	2			mA
V <sub>OL</sub>	Low-level output voltage SDA/CFG1	V <sub>CC</sub> = 3.0V; VIO = 1.8V or 3.3V;	-0.3		0.4	V
I <sub>OL</sub>	Low-level output current SDA/CFG1	V <sub>CC</sub> = 3.0V; VIO = 1.8V or 3.3V;	4			mA
I <sub>IL_I2C</sub>	Low-level input current SCL/CFG0, SDA/CFG1	V <sub>IN</sub> = 0V; VIO = 1.8V or 3.3V;	-1		1	μA
I <sub>LEAK</sub>	Fail-safe input current for SCL/CFG0, SDA/CFG1	V <sub>IN</sub> = 3.6V; VCC = 0V;	-25		25	μA
V <sub>IL_EN</sub>	Low-level input voltage for EN pin.	VIO = 1.14V; VCC = 3.3V;	-0.3		0.4	V
V <sub>IH_EN</sub>	High-level input voltage for EN pin.	VIO = 3.6V; VCC = 3.3V;	0.8		3.6	V
I <sub>IL</sub>	Low-level input current EN	V <sub>IN</sub> = 0V; VIO = 1.8V or 3.3V; VCC = 3.6V	-20		20	μA
I <sub>IL</sub>	Low-level input current AC_EN	V <sub>IN</sub> = 0V; VIO = 1.8V or 3.3V;	-1		1	μA
I <sub>IH_EN</sub>	High-level input current for EN	V <sub>IN</sub> = 3.6V; VIO = 1.8V or 3.3V;	-1		1	μA
I <sub>IH_ACEN</sub>	High-level input current for AC_EN	V <sub>IN</sub> = 3.6V; VIO = 1.8V or 3.3V;	-24		24	μA
R <sub>PU_EN</sub>	Internal Pull-up resistance on EN.		125	250	350	kΩ
R <sub>PD_ACE N</sub>	Internal Pull-down resistance on AC_EN		125	250	350	kΩ

## 5.5 Electrical Characteristics (continued)

over recommended voltage and operating free-air temperature range (unless otherwise noted)

PARAMETER		TEST CONDITIONS	MIN	TYP	MAX	UNIT
$C_{I2C-PINS}$	Capacitance for SCL/CFG0 and SDA/CFG1	$f = 100 \text{ kHz}$ ;			5	pF
$C_{(I2C\_FM+ \_BUS)}$	I2C bus capacitance for FM+ (1MHz)				150	pF
$C_{(I2C\_FM\_ \_BUS)}$	I2C bus capacitance for FM (400 kHz)				150	pF
$R_{(EXT\_I2C \_FM+)}$	External resistors on both SDA and SCL when operating at FM+ (1MHz)	$C_{(I2C\_FM+ \_BUS)} = 150\text{pF}$	620	820	910	$\Omega$
$R_{(EXT\_I2C \_FM)}$	External resistors on both SDA and SCL when operating at FM (400 kHz)	$C_{(I2C\_FM\_ \_BUS)} = 150\text{pF}$	620	1500	2200	$\Omega$
<b>LV_DDC_SDA and LV_DDC_SCL</b>						
$V_{IL\_1p2V}$	Low-level input voltage	$V_{CC} = 3.0\text{V}$ ;	-0.3		0.360	V
$V_{IH\_1p2V}$	High-level input voltage	$V_{CC} = 3.6\text{V}$ ;	0.8		3.6	V
$V_{IL\_1p8V}$	Low-level input voltage	$V_{CC} = 3.0\text{V}$ ;	-0.3		0.57	V
$V_{IH\_1p8V}$	High-level input voltage	$V_{CC} = 3.6\text{V}$ ;	1.19		3.6	V
$V_{IL\_3p3V}$	Low-level input voltage	$V_{CC} = 3.0\text{V}$ ;	-0.3		0.8	V
$V_{IH\_3p3V}$	High-level input voltage	$V_{CC} = 3.6\text{V}$ ;	2.2		3.6	V
$R_{PULV}$	Internal pull-up resistor to VIO		7450	10000	13000	$\Omega$
$\Delta V_{LV\_HYST\_3p3V}$	Hysteresis on LV side for 3.3V LVCMOS	$V_{IO} = 3.3\text{V}$ ; $V_{CC} = 3.3\text{V}$		50		mV
<b>SIGDET_OUT</b>						
$V_{OL}$	Low level output voltage	$V_{CC} = 3.0\text{V}$ ;	-0.3		0.4	V
$I_{OL}$	Low level output current	$V_{CC} = 3.0\text{V}$ ;	4			mA
$I_{HIZ}$	Leakage current when output disabled	$V_{CC} = 3.6\text{V}$ ; Pulled up to 3.6V through 10k $\Omega$	-5		5	$\mu\text{A}$
<b>HPD_IN</b>						
$V_{IL-HPDIN}$	Low-level input voltage for HPD_IN	$V_{CC} = 3.6\text{V}$ ;	-0.3		0.8	V
$V_{IH-HPDIN}$	High-level input voltage for HPD_IN	$V_{CC} = 3.6\text{V}$	2.0		5.5	V
$I_{H-HPDIN}$	High-level input current for HPD_IN	Device powered; $V_{IH} = 5.5\text{V}$ ; Includes internal pull-down resistor	-50		50	$\mu\text{A}$
$I_{L-HPDIN}$	Low-level input current for HPD_IN	Device powered; $V_{IL} = 0\text{V}$ ; Includes internal pull-down resistor	-1		1	$\mu\text{A}$
$R_{PD-HPDIN}$	Internal Pull-down resistance on HPD_IN	$V_{CC} = 3.3\text{V}$ ; $HPD\_IN = 5.5\text{V}$	110	150	210	k $\Omega$
$I_{LEAK-HPDIN}$	Fail-safe condition leakage current for HPD_IN	$V_{CC} = 0\text{V}$ ; $HPD\_IN = 5.5\text{V}$	-50		50	$\mu\text{A}$
<b>HPD_OUT</b>						
$V_{OH\_3p3V}$	High level output voltage when configured for 3.3V LVCMOS push/pull.	$V_{CC} = 3.0\text{V}$ ;	2.4		3.465	V
$V_{OH\_1p8V}$	High level output voltage when configured for 1.8V LVCMOS push/pull.	$V_{CC} = 3.0\text{V}$ ;	1.3		1.95	V
$V_{OL\_PP}$	Low level output voltage when configured for push/pull.	$V_{CC} = 3.0\text{V}$ ;	-0.3		0.4	V
$V_{OL\_OD}$	Low level output voltage when configured for open drain.	$V_{CC} = 3.0\text{V}$ ; 0.5 k $\Omega$ to 3.6V load;	-0.3		0.4	V
$I_{OH\_3p3V}$	High level output current for 3.3V LVCMOS	$HPD\_IN = V_{IH-HPDIN}$ ;			-4	mA
$I_{OL\_3p3V}$	Low level output current for 3.3V LVCMOS	$HPD\_IN = V_{IL-HPDIN}$ ; I <sub>2</sub> C mode;	4			mA

## 5.5 Electrical Characteristics (continued)

over recommended voltage and operating free-air temperature range (unless otherwise noted)

PARAMETER		TEST CONDITIONS	MIN	TYP	MAX	UNIT
$I_{OH\_1p8V}$	High level output current for 1.8V LVCMOS	HPD_IN = $V_{IH-HPDIN}$ ;			-1.1	mA
$I_{OL\_1p8V}$	Low level output current for 1.8V LVCMOS	HPD_IN = $V_{IL-HPDIN}$ ; I <sub>2C</sub> mode;	1.2			mA
<b>4-LEVEL CONTROL (MODE, LINEAR_EN, EQ1, ADDR/EQ0, TXSLEW, TXPRE, TXSWG, DCGAIN)</b>						
$V_{TH}$	Threshold "0" / "R"	$V_{CC} = 3.3V$		0.55		V
$V_{TH}$	Threshold "R" / "F"	$V_{CC} = 3.3V$		1.65		V
$V_{TH}$	Threshold "F" / "1"	$V_{CC} = 3.3V$		2.7		V
$I_{IH}$	High-level input current	$V_{IH} = 3.6V$ ; $V_{CC} = 3.6V$ ;	20		60	μA
$I_{IL}$	Low-level input current	$V_{IL} = 0V$ ; $V_{CC} = 3.6V$ ;	-100		-40	μA
$R_{4PU}$	Internal pullup resistance			48		kΩ
$R_{4PD}$	Internal pull-down resistance			98		kΩ
<b>HDMI HIGH SPEED INPUTS</b>						
$D_{R\_RX\_DA}$ TA	Data lanes data rate		0.25		12	Gbps
$D_{R\_RX\_CL}$ K	Clock lane data rate		0.25		12	Gbps
$V_{ID(DC)}$	DC differential input swing	At pins; LINEAR_EN = L;	400		1200	mVpp
$V_{ID(EYE)}$	Differential input swing eye opening	At pins;	75			mVpp
$V_{RX\_ASSE}$ RT	Signal detect assert level.	PRBS7 pattern; 12Gbps;		180		mVpp
$V_{RX\_DEAS}$ SERT	Signal detect deassert level.	PRBS7 pattern; 12Gbps;		110		mVpp
$V_{ICM-DC}$	Input DC common mode voltage bias	At pins;	2.5	3.3	VCC	V
$E_{EQ\_12Gb}$ s_MAX_LT	Maximum Fixed EQ gain (AC - DC)	At 6GHz; 12Gbps CTLE; EQ15; DC Gain = 0dB; Limited Mode; At output of RX;		12		dB
$E_{EQ\_12Gb}$ ps_MIN_LT	Minimum Fixed EQ gain (AC - DC)	At 6GHz; 12Gbps CTLE; EQ0; DC Gain = 0dB; Limited Mode; At output of RX;		1.0		dB
$E_{EQ\_12Gb}$ ps_BYPASS _LT	Maximum Fixed EQ Gain when EQ is bypassed. (AC - DC)	At 6GHz; 12Gbps CTLE; DC Gain = 0dB; Limited Mode; At output of RX;		-1.5		dB
$E_{EQ\_6Gbps}$ _MAX_LT	Maximum Fixed EQ gain (AC - DC)	At 3GHz; 6Gbps CTLE; EQ15; DC Gain = 0dB; Limited Mode; At output of RX;		12.0		dB
$E_{EQ\_6Gbps}$ s_MIN_LT	Minimum Fixed EQ gain (AC - DC)	At 3GHz; 6Gbps CTLE; EQ0; DC Gain = 0dB; Limited Mode; At output of RX;		0.6		dB
$E_{EQ\_3Gbps}$ _MAX_LT	Maximum Fixed EQ gain (AC - DC)	At 1.5GHz; 3Gbps CTLE; EQ15; DC Gain = 0dB; Limited Mode; At output of RX;		12		dB
$E_{EQ\_3Gbps}$ s_MIN_LT	Minimum Fixed EQ gain (AC - DC)	At 1.5GHz; 3Gbps CTLE; EQ0; DC Gain = 0dB; Limited Mode; At output of RX;		0.8		dB
$R_{INT}$	Input differential impedance when termination is enabled	At TTP2; HPD_IN = H; 0°C ≤ T <sub>A</sub> ≤ 70°C	90	100	110	Ω
$R_{INT}$	Input differential impedance when termination is enabled	At TTP2; HPD_IN = H; -20°C ≤ T <sub>A</sub> ≤ 85°C	85	100	115	Ω
<b>HDMI HIGH SPEED OUTPUTS (Limited Mode)</b>						
$V_{OL\_open}$	Single-ended low-level output voltage for DR ≤ 1.65Gbps data rate	DR = 270 Mbps; HPD_IN = H; AC_EN = L (DC-coupled); TXSWG = "F" (1000mV); TXPRE = "F" (0dB); TX termination open; VCC_EXT = 3.3V; 25°C ≤ T <sub>A</sub> ≤ 85°C;	2.7		2.9	V

## 5.5 Electrical Characteristics (continued)

over recommended voltage and operating free-air temperature range (unless otherwise noted)

PARAMETER		TEST CONDITIONS	MIN	TYP	MAX	UNIT
$V_{OL\_300}$	Single-ended low-level output voltage 1.65Gbps < DR ≤ 3.4Gbps.	DR = 3.4Gbps; HPD_IN = H; AC_EN = L (DC-coupled); TXSWG = "F" (1000mV); TXPRE = "F" (0dB); TX termination 300Ω; VCC_EXT = 3.3V; 25°C ≤ T <sub>A</sub> ≤ 85°C;	2.6		2.9	V
$V_{OL\_DAT20}$	Data lane single-ended low-level output voltage 3.4Gbps < DR ≤ 6Gbps.	DR = 5.94Gbps; HPD_IN = H; AC_EN = L (DC-coupled); TXSWG = "F" (1000mV); TXPRE = "F" (0dB); VCC_EXT = 3.3V; 25°C ≤ T <sub>A</sub> ≤ 85°C;	2.3		2.9	V
$V_{SWING\_DA14}$	Single-ended output voltage swing on data lanes with TX term set to open.	DR = 1.5Gbps; HPD_IN = H; AC_EN = L (DC-coupled); TXSWG = "F" (1000mV); TXPRE = "F" (0dB); VCC_EXT = 3.3V; 25°C ≤ T <sub>A</sub> ≤ 85°C;	400	500	600	mV
$V_{SWING\_DA14}$	Single-ended output voltage swing on data lanes with TX term set to 300Ω.	DR = 3.4Gbps; HPD_IN = H; AC_EN = L (DC-coupled); TXSWG = "F" (1000mV); TXPRE = "F" (0dB); VCC_EXT = 3.3V; 25°C ≤ T <sub>A</sub> ≤ 85°C;	400	500	600	mV
$V_{SWING\_DA20}$	Single-ended output voltage swing on data lanes for HDMI2.0 operation.	DR = 5.94Gbps; HPD_IN = H; AC_EN = L (DC-coupled); TXSWG = "F" (1000mV); TXPRE = "F" (0dB); VCC_EXT = 3.3V; 25°C ≤ T <sub>A</sub> ≤ 85°C;	400	500	600	mV
$V_{SWING\_CLK14\_OPEN}$	Single-ended output voltage swing on clock lane for DR ≤ 3.4Gbps data rate	HPD_IN = H; AC_EN = L (DC-coupled); TXSWG = "F" (1000mV); TXPRE = "F" (0dB); VCC_EXT = 3.3V; 25°C ≤ T <sub>A</sub> ≤ 85°C; TERM set to open;	400	500	600	mV
$V_{SWING\_CLK20}$	Single-ended output voltage swing on clock lane for HDMI 2.0	HPD_IN = H; AC_EN = L (DC-coupled); TXSWG = "F" (1000mV); TXPRE = "F" (0dB); VCC_EXT = 3.3V; 25°C ≤ T <sub>A</sub> ≤ 85°C;	300	400	600	mV
$V_{OCM\_DC\_ON}$	FRL DC common mode voltage when actively transmitting	At TTP4; AC_EN = L or H; LTP5, 6, 7 or 8; TXFFE0; 25°C ≤ T <sub>A</sub> ≤ 85°C;	2.335		3.495	V
$V_{OCM\_DC\_OFF}$	FRL DC common mode voltage when lane 3 is disabled	At TTP4; FRL 3 lane mode; AC_EN = L or H; 25°C ≤ T <sub>A</sub> ≤ 85°C;	2.335		3.495	V
$V_{OD\_3G}$	Data lanes Differential output swing	At TTP4; 2.97Gbps; HPD_IN = H; AC_EN = L or H; TXSWG = "F" (1000mV); TXPRE = "F" (0dB); 25°C ≤ T <sub>A</sub> ≤ 85°C;	400		1560	mV
$V_{OD\_6G}$	Data lanes Differential output swing	At TTP4_EQ; 5.94Gbps; HPD_IN = H; AC_EN = L or H; TXSWG = "F" (1000mV); TXPRE = "F" (0dB); 25°C ≤ T <sub>A</sub> ≤ 85°C;	150		1560	mV
$V_{OD\_12G\_FRL}$	Data lanes Differential output swing at 12 G FRL.	At TTP4_EQ; 12Gbps; HPD_IN = H; AC_EN = L or H; TXSWG = "F" (1000mV); TXFFE0; 25°C ≤ T <sub>A</sub> ≤ 85°C;	100		1560	mV
$I_{LEAK}$	Failsafe condition leakage current	V <sub>CC</sub> = 0V; DC-coupled; TMDS output pulled to 3.465V with 50 Ω resistors			35	μA
$I_{OS}$	Short circuit current limit	OUT_CLK, OUT_D[2:0] outputs P or N shorted to GND			70	mA
$R_{TERM14}$	Internal termination for DR ≤ 3.4Gbps when DC-coupled	TERM = 1h; AC_EN = L (DC-coupled); HPD_IN=H; Active state; -20°C ≤ T <sub>A</sub> ≤ 85°C;	235	295	375	Ω
$R_{TERM14}$	Internal termination for DR ≤ 3.4Gbps when AC-coupled	TERM = 1h; AC_EN = H (AC-coupled); HPD_IN=H; Active state; -20°C ≤ T <sub>A</sub> ≤ 85°C;	235	295	375	Ω
$R_{TERM2+}$	Internal termination for DR > 3.4Gbps when DC-coupled.	TERM = 3h; AC_EN = L (DC-coupled); HPD_IN=H; Active state; -20°C ≤ T <sub>A</sub> ≤ 85°C;	85	100	115	Ω

### 5.5 Electrical Characteristics (continued)

over recommended voltage and operating free-air temperature range (unless otherwise noted)

PARAMETER		TEST CONDITIONS	MIN	TYP	MAX	UNIT
R <sub>TERM2+</sub>	Internal termination for DR > 3.4Gbps when AC-coupled.	TERM = 3h; AC_EN = H (AC-coupled); HPD_IN=H; Active state; -20°C ≤ T <sub>A</sub> ≤ 85°C;	85	100	115	Ω
V <sub>TXPRE0-RATIO</sub>	Transmitter FFE pre-emphasis ratio for 0dB.	TERM = 3h; HPD_IN = H; TX_AC_EN = 0; CLK_TXFFE = 0h; CLK_VOD = 3h; D0_TXFFE = 0h; D0_VOD = 3h; D1_TXFFE = 0h; D1_VOD = 3h; D2_TXFFE = 0h; D2_VOD = 3h; 20 * log (Vp/Vn); 128 zeros followed by 128 ones;		0		dB
V <sub>TXPRE1-RATIO</sub>	Transmitter FFE pre-emphasis ratio for 3.5dB for data lanes	At 5.94Gbps HDMI 2.0; TERM = 3h; HPD_IN = H; TX_AC_EN = 0; CLK_TXFFE = 0h; CLK_VOD = 3h; D0_TXFFE = 1h; D0_VOD = 3h; D1_TXFFE = 1h; D1_VOD = 3h; D2_TXFFE = 1h; D2_VOD = 3h; 20 * log (Vp/Vn); 128 zeros followed by 128 ones;		4.0		dB
V <sub>TXPRE2-RATIO</sub>	Transmitter FFE pre-emphasis ratio for 6dB for data lanes	At 5.94Gbps HDMI 2.0; TERM = 3h; HPD_IN = H; TX_AC_EN = 0; CLK_TXFFE = 0h; CLK_VOD = 3h; D0_TXFFE = 2h; D0_VOD = 3h; D1_TXFFE = 2h; D1_VOD = 3h; D2_TXFFE = 2h; D2_VOD = 3h; 20 * log (Vp/Vn); 128 zeros followed by 128 ones;		6.5		dB
V <sub>TXFFE0-RATIO</sub>	Transmitter FRL TXFFE0 de-emphasis ratio	At 12Gbps FRL; TERM = 3h; HPD_IN = H; TX_AC_EN = 0; CLK_TXFFE = 4h; CLK_VOD = 3h; D0_TXFFE = 4h; D0_VOD = 3h; D1_TXFFE = 4h; D1_VOD = 3h; D2_TXFFE = 4h; D2_VOD = 3h; 20 * log (Vp/Vn); 128 zeros followed by 128 ones;		-2.5		dB
V <sub>TXFFE1-RATIO</sub>	Transmitter FRL TXFFE1 de-emphasis ratio	At 12Gbps FRL; TERM = 3h; HPD_IN = H; TX_AC_EN = 0; CLK_TXFFE = 5h; CLK_VOD = 3h; D0_TXFFE = 5h; D0_VOD = 3h; D1_TXFFE = 5h; D1_VOD = 3h; D2_TXFFE = 5h; D2_VOD = 3h; 20 * log (Vp/Vn); 128 zeros followed by 128 ones;		-3.2		dB
V <sub>TXFFE2-RATIO</sub>	Transmitter FRL TXFFE2 de-emphasis ratio.	At 12Gbps FRL; TERM = 3h; HPD_IN = H; TX_AC_EN = 0; CLK_TXFFE = 6h; CLK_VOD = 3h; D0_TXFFE = 6h; D0_VOD = 3h; D1_TXFFE = 6h; D1_VOD = 3h; D2_TXFFE = 6h; D2_VOD = 3h; 20 * log (Vp/Vn); 128 zeros followed by 128 ones;		-3.5		dB
V <sub>TXFFE3-RATIO</sub>	Transmitter FRL TXFFE3 de-emphasis ratio	At 12Gbps FRL; TERM = 3h; HPD_IN = H; TX_AC_EN = 0; CLK_TXFFE = 7h; CLK_VOD = 3h; D0_TXFFE = 7h; D0_VOD = 3h; D1_TXFFE = 7h; D1_VOD = 3h; D2_TXFFE = 7h; D2_VOD = 3h; 20 * log (Vp/Vn); 128 zeros followed by 128 ones;		-4.5		dB
<b>HDMI HIGH SPEED OUTPUTS (Linear Mode)</b>						
CP <sub>LF-TXSWG-0</sub>	Low-frequency 1dB compression point D <sub>x</sub> _VOD = 0.	At 10MHz; 200mVpp < V <sub>ID</sub> < 1200mVpp; EQ0; DCGAIN = 0dB; 12Gbps CTLE; CTLEBYP_EN = 0; BERT TX 100MHz clock starting at 200mV to 1200mV in 50mV steps;TX DC coupled to VCC_EXT;		900		mVpp

## 5.5 Electrical Characteristics (continued)

over recommended voltage and operating free-air temperature range (unless otherwise noted)

PARAMETER		TEST CONDITIONS	MIN	TYP	MAX	UNIT
CP <sub>HF-TXSWG-0</sub>	High-frequency 1dB compression point Dx_VOD = 0.	At 6GHz; 200mVpp < V <sub>ID</sub> < 1200mVpp; EQ0; DCGAIN = 0dB; 12Gbps CTLE; CTLEBYP_EN = 0; TX DC coupled to VCC_EXT;		750		mVpp
CP <sub>LF-TXSWG-R</sub>	Low-frequency 1dB compression point Dx_VOD = 1.	At 10MHz; 200mVpp < V <sub>ID</sub> < 1200mVpp; EQ0; DCGAIN = 0dB; 12Gbps CTLE; CTLEBYP_EN = 0; BERT TX 100MHz clock starting at 200mV to 1200mV in 50mV steps; TX DC coupled to VCC_EXT;		1000		mVpp
CP <sub>HF-TXSWG-R</sub>	High-frequency 1dB compression point Dx_VOD = 1.	At 6GHz; 200mVpp < V <sub>ID</sub> < 1200mVpp; EQ0; DCGAIN = 0dB; 12Gbps CTLE; CTLEBYP_EN = 0; TX DC coupled to VCC_EXT;		800		mVpp
CP <sub>LF-TXSWG-F</sub>	Low-frequency 1dB compression point Dx_VOD = 2.	At 10MHz; 200mVpp < V <sub>ID</sub> < 1200mVpp; EQ0; DCGAIN = 0dB; 12Gbps CTLE; CTLEBYP_EN = 0; BERT TX 100MHz clock starting at 200mV to 1200mV in 50mV steps; TX DC coupled to VCC_EXT;		1100		mVpp
CP <sub>HF-TXSWG-F</sub>	High-frequency 1dB compression point Dx_VOD = 2.	At 6GHz; 200mVpp < V <sub>ID</sub> < 1200mVpp; EQ0; DCGAIN = 0dB; 12Gbps CTLE; CTLEBYP_EN = 0; TX DC coupled to VCC_EXT;		875		mVpp
CP <sub>LF-TXSWG-1</sub>	Low-frequency 1dB compression point Dx_VOD = 3.	At 10MHz; 200mVpp < V <sub>ID</sub> < 1200mVpp; EQ0; DCGAIN = 0dB; 12Gbps CTLE; CTLEBYP_EN = 0; BERT TX 100MHz clock starting at 200mV to 1200mV in 50mV steps; TX DC coupled to VCC_EXT;		1200		mVpp
CP <sub>HF-TXSWG-1</sub>	High-frequency 1dB compression point Dx_VOD = 3.	At 6GHz; 200mVpp < V <sub>ID</sub> < 1200mVpp; EQ0; DCGAIN = 0dB; 12Gbps CTLE; CTLEBYP_EN = 0; TX DC coupled to VCC_EXT;		950		mVpp
<b>RCLKOUT</b>						
V <sub>TX-CM</sub>	Output common mode voltage		2.4	2.8	3.465	V
V <sub>ODPP</sub>	Peak-to-peak output voltage swing		600	700	1100	mV
R <sub>TERM</sub>	Differential output impedance		70	100	120	Ω
t <sub>RF</sub>	Rise and fall time	20% to 80%	100		370	ps
C <sub>TX-AC</sub>	Required external AC capacitor		8	10	12	nF

## 5.6 Timing Requirements

		MIN	NOM	MAX	UNIT
<b>Local I2C (SCL/CFG0, SDA/CFG1). Refer to Figure 6-9.</b>					
f <sub>SCL</sub>	I <sup>2</sup> C clock frequency			1	MHz
t <sub>BUF</sub>	Bus free time between START and STOP conditions	0.5			μs
t <sub>HD_STA</sub>	Hold time after repeated START condition. After this period, the first clock pulse is generated	0.26			μs
t <sub>LOW</sub>	Low period of the I <sup>2</sup> C clock	0.5			μs
t <sub>HIGH</sub>	High period of the I <sup>2</sup> C clock	0.26			μs
t <sub>SU_STA</sub>	Setup time for a repeated START condition	0.26			μs
t <sub>HD_DAT</sub>	Data hold time	0			μs

## 5.6 Timing Requirements (continued)

		MIN	NOM	MAX	UNIT
$t_{SU\_DAT}$	Data setup time	50			ns
$t_R$	Rise time of both SDA and SCL signals			120	ns
$t_F$	Fall time of both SDA and SCL signals	4		120	ns
$t_{SU\_STO}$	Setup time for STOP condition	0.26			$\mu$ s
<b>DDC Snoop I2C Timings. Refer to Figure 6-9.</b>					
$f_{SCL}$	I <sup>2</sup> C DDC clock frequency			100	kHz
$t_{BUF}$	Bus free time between START and STOP conditions	4.7			$\mu$ s
$t_{HD\_STA}$	Hold time after repeated START condition. After this period, the first clock pulse is generated	4			$\mu$ s
$t_{LOW}$	Low period of the I <sup>2</sup> C clock	4.7			$\mu$ s
$t_{HIGH}$	High period of the I <sup>2</sup> C clock	4			$\mu$ s
$t_{SU\_STA}$	Setup time for a repeated START condition	4.7			$\mu$ s
$t_{HD\_DAT}$	Data hold time	0			$\mu$ s
$t_{SUDAT}$	Data setup time	250			ns
$t_R$	Rise time of both SDA and SCL signals. Measured from 30% to 70%.			1000	ns
$t_F$	Fall time of both SDA and SCL signals Measured from 70% to 30%.			300	ns
$t_{SU\_STO}$	Setup time for STOP condition	4			$\mu$ s
$C_{b\_LV}$	Capacitive load for each bus line on LV side			50	pF
<b>Power-On. Refer to Figure 6-1.</b>					
$t_{VCC\_RAMP}$	$V_{CC}$ supply ramp. Measured from 10% to 90%.	0.10		50	ms
$t_{D\_PG}$	Internal POR de-assertion delay			5	ms
$t_{VIO\_SU}$	$V_{IO}$ supply stable before reset <sup>(2)</sup> high.	100			$\mu$ s
$t_{CFG\_SU}$	Configuration pins <sup>(1)</sup> setup before reset <sup>(2)</sup> high.	0			$\mu$ s
$t_{CFG\_HD}$	Configuration pins <sup>(1)</sup> hold after reset <sup>(2)</sup> high.	500			$\mu$ s

(1) Follow comprise the configuration pins: MODE, ADDR/EQ0, EQ1, TXSWG, TXSLEW, TXPRE, AC\_EN, HPDOUT\_SEL, DCGAIN

(2) Reset is the logical AND of internal POR and EN pin.

## 5.7 Switching Characteristics

over recommended voltage and operating free-air temperature range (unless otherwise noted)

PARAMETER		TEST CONDITIONS	MIN	TYP	MAX	UNIT
<b>Redriver</b>						
$f_{HDMI14\_open}$	Maximum HDMI 1.4 clock frequency at which TX termination is assured to be open	HDMI1.4; 25MHz $\leq$ IN_CLK $\leq$ 340MHz; TXTERM_AUTO_HDMI14 = 0h; TERM = 2h; TX is DC-coupled;	165			MHz
$f_{HDMI14\_300}$	Minimum HDMI 1.4 clock frequency at which TX termination is assured to be 300 $\Omega$	HDMI1.4; 25MHz $\leq$ IN_CLK $\leq$ 340MHz; TXTERM_AUTO_HDMI14 = 0h; TERM = 2h; TX is DC-coupled;			250	MHz
$t_{AEQ\_DONE}$	Time from start of FRL link training to AEQ complete for 3Gbps.				0.7	ms
$t_{AEQ\_DONE}$	Time from start of FRL link training to AEQ complete for 6Gbps, 8Gbps, 10Gbps, and 12Gbps				0.5	ms
$t_{PD}$	Propagation delay time	At TTP4;	90		220	ps
$t_{SK1(T)}$	Clock lane Intra-pair output skew with worse case skew at inputs	At TTP4; With 0.15 UI skew at input; At 6Gbps with 150MHz clock; TX termination 100 $\Omega$ ; Linear mode;			0.15	UI

## 5.7 Switching Characteristics (continued)

over recommended voltage and operating free-air temperature range (unless otherwise noted)

PARAMETER		TEST CONDITIONS	MIN	TYP	MAX	UNIT
$t_{SK1(T)}$	Data lane Intra-pair output skew with worse case skew at inputs	At TTP4; With 0.15 UI skew at input; At 12Gbps; LTP5, 6, 7, or 8; TXFFE0; TX termination 100 $\Omega$ ; Linear mode;			0.15	UI
$t_{SK1(T)}$	Clock lane Intra-pair output skew with zero intra-pair skew at inputs	At TTP4; No intra-pair skew at input; 6Gbps with 150MHz clock; TX termination 100 $\Omega$ ; Limited mode;		0.10	0.15	UI
$t_{SK1(T)}$	Data lane Intra-pair output skew with zero intra-pair skew at inputs	At TTP4; No intra-pair skew at input; At 12Gbps; LTP5, 6, 7, or 8; TXFFE0; TX termination 100 $\Omega$ ; Limited mode;		0.053	0.11	UI
$t_{SK2(T)}$	Inter-pair output skew	At TTP4; At 12Gbps; LTP5, 6, 7, or 8; TXFFE0;			30	ps
$t_{RF-CLK-14}$	Transition time (rise and fall time) for clock lane when operating at HDMI 1.4	At TTP4; 20% to 80%; Clock Frequency = 300MHz;	75		600	ps
$t_{RF-CLK-20}$	Transition time (rise and fall time) for clock lane when operating at HDMI 2.0	At TTP4; 20% to 80%; Clock Frequency = 150MHz;	75		600	ps
$t_{RF\_14}$	Transition time (rise and fall time) for data lanes when operating at HDMI 1.4	At TTP4; 20% to 80%; DR = 3Gbps; SLEW_HDMI14 = default; PRBS7 pattern; Clock Frequency = 300MHz;	75		195	ps
$t_{RFDAT\_20}$	Transition time (rise and fall time) for data lanes when operating at HDMI 2.0	At TTP4; 20% to 80%; DR = 6Gbps; SLEW_HDMI20 = default; PRBS7 pattern; Clock Frequency = 150MHz;	42.5		115	ps
$t_{SLEW\_FRL}$	Single-ended TX slew rate for data lanes when operating at HDMI 2.1 FRL	At TTP4; Slope at 50% level; All FRL DR up to 12Gbps; SLEW_HDMI21 = Default; clock pattern of 128 zeros and 128 ones;			16	mV/ps
$t_{TRANS\_3G}$	Transition bit duration when de-emphasis/pre-emphasis is enabled	At TTP4; DR = 3Gbps; Clock pattern of 128 zeros followed by 128 ones;	0.4		1	UI
$t_{TRANS\_6G}$	Transition bit duration when de-emphasis/pre-emphasis is enabled	At TTP4; DR = 6Gbps; Clock pattern of 128 zeros followed by 128 ones;	0.4		1	UI
$t_{TRANS\_8G}$	Transition bit duration when de-emphasis/pre-emphasis is enabled	At TTP4; DR = 8Gbps; Clock pattern of 128 zeros followed by 128 ones;	0.4		1	UI
$t_{TRANS\_10G}$	Transition bit duration when de-emphasis/pre-emphasis is enabled	At TTP4; DR = 10Gbps; Clock pattern of 128 zeros followed by 128 ones;	0.5		1.1	UI
$t_{TRANS\_12G}$	Transition bit duration when de-emphasis/pre-emphasis is enabled	At TTP4; DR = 12Gbps; Clock pattern of 128 zeros followed by 128 ones;	0.6		1.3	UI
<b>HPD</b>						
$t_{HPD\_PD}$	HPD_IN to HPD_OUT propagation delay	Refer to <a href="#">Figure 6-7</a>			100	$\mu$ s
$t_{HPD\_PWR\ DOWN}$	HPD_IN debounce time before declaring Powerdown. Enter Powerdown if HPD_IN is low after debounce time.	Refer to <a href="#">Figure 6-7</a>	2		4	ms
$t_{HPD\_STANDBY}$	HPD_IN debounce time required for exiting Powerdown to Standby. Exit Powerdown if HPD_IN is high after debounce time.	Refer to <a href="#">Figure 6-8</a>	2		4	ms
<b>Standby</b>						
$t_{STANDBY\_ENTRY}$	Detection of electrical idle to entry into Standby.	HPD_IN = H;			300	$\mu$ s
$t_{SIGDET\_DB}$	Maximum differential signal glitch time rejected during debounce before transitioning from standby to active	HPD_IN = H;			25	$\mu$ s
$t_{SIGDET\_DB}$	Maximum differential signal glitch time rejected during debounce before transitioning from active to standby	HPD_IN = H;			50	ns

## 5.7 Switching Characteristics (continued)

over recommended voltage and operating free-air temperature range (unless otherwise noted)

PARAMETER		TEST CONDITIONS	MIN	TYP	MAX	UNIT
$t_{\text{STANDBY\_EXIT}}$	Detection of differential signal to exit from Standby to Active state when SIGDET_OUT low.	HPD_IN = H; Does not include AEQ time if AEQ_TX_DELAY_EN = 1;			200	$\mu\text{s}$
$f_{\text{SCL}}$	DDC buffer frequency				100	kHz
$t_{\text{PLH1}}$	Propagation delay time. Low-to-high-level output. VIO set to 1.2V LVCMOS levels.	LV to HV; $C_{\text{LV\_BUS}} = C_{\text{HV\_BUS}} = 50\text{pF}$ ; DDC_LV_DCC_EN = 1'b1;			1400	ns
	Propagation delay time. Low-to-high-level output. VIO set to 1.8V LVCMOS levels.	LV to HV; $C_{\text{LV\_BUS}} = C_{\text{HV\_BUS}} = 50\text{pF}$ ; DDC_LV_DCC_EN = 1'b1;			1400	ns
	Propagation delay time. Low-to-high-level output. VIO set to 3.3V LVCMOS levels.	LV to HV; $C_{\text{LV\_BUS}} = C_{\text{HV\_BUS}} = 50\text{pF}$ ; DDC_LV_DCC_EN = 1'b1;			1400	ns
$t_{\text{PLH2}}$	Propagation delay time. Low-to-high-level output. VIO set to 1.2V LVCMOS levels.	HV to LV; $C_{\text{LV\_BUS}} = C_{\text{HV\_BUS}} = 50\text{pF}$ ; DDC_LV_DCC_EN = 1'b1;			410	ns
	Propagation delay time. Low-to-high-level output. VIO set to 1.8V LVCMOS levels.	HV to LV; $C_{\text{LV\_BUS}} = C_{\text{HV\_BUS}} = 50\text{pF}$ ; DDC_LV_DCC_EN = 1'b1;			410	ns
	Propagation delay time. Low-to-high-level output. VIO set to 3.3V LVCMOS levels.	HV to LV; $C_{\text{LV\_BUS}} = C_{\text{HV\_BUS}} = 50\text{pF}$ ; DDC_LV_DCC_EN = 1'b1;			410	ns
$t_{\text{PHL1}}$	Propagation delay time. High to low-level output. VIO set to 1.2V LVCMOS.	LV to HV; $C_{\text{LV\_BUS}} = C_{\text{HV\_BUS}} = 50\text{pF}$ ; DDC_LV_DCC_EN = 1'b1;			1200	ns
	Propagation delay time. High to low-level output. VIO set to 1.8V LVCMOS.	LV to HV; $C_{\text{LV\_BUS}} = C_{\text{HV\_BUS}} = 50\text{pF}$ ; DDC_LV_DCC_EN = 1'b1;			1200	ns
	Propagation delay time. High to low-level output. VIO set to 3.3V LVCMOS.	LV to HV; $C_{\text{LV\_BUS}} = C_{\text{HV\_BUS}} = 50\text{pF}$ ; DDC_LV_DCC_EN = 1'b1;			1200	ns
$t_{\text{PHL2}}$	Propagation delay time. High to low-level output. VIO set to 1.2V LVCMOS.	HV to LV; $C_{\text{LV\_BUS}} = C_{\text{HV\_BUS}} = 50\text{pF}$ ; DDC_LV_DCC_EN = 1'b1;			535	ns
	Propagation delay time. High to low-level output. VIO set to 1.8V LVCMOS.	HV to LV; $C_{\text{LV\_BUS}} = C_{\text{HV\_BUS}} = 50\text{pF}$ ; DDC_LV_DCC_EN = 1'b1;			535	ns
	Propagation delay time. High to low-level output. VIO set to 3.3V LVCMOS.	HV to LV; $C_{\text{LV\_BUS}} = C_{\text{HV\_BUS}} = 50\text{pF}$ ; DDC_LV_DCC_EN = 1'b1;			535	ns
$t_{\text{LV\_FALL}}$	LV side fall time for 1.2V LVCMOS	70% to 30%; $C_{\text{LV\_BUS}} = C_{\text{HV\_BUS}} = 50\text{pF}$ ;	75		260	ns
	LV side fall time for 1.8V LVCMOS	70% to 30%; $C_{\text{LV\_BUS}} = C_{\text{HV\_BUS}} = 50\text{pF}$ ;	75		260	ns
	LV side fall time for 3.3V LVCMOS	70% to 30%; $C_{\text{LV\_BUS}} = C_{\text{HV\_BUS}} = 50\text{pF}$ ;	75		260	ns
$t_{\text{HV\_FALL}}$	HV side fall time	70% to 30%; $C_{\text{LV\_BUS}} = C_{\text{HV\_BUS}} = 50\text{pF}$ ;	75		260	ns
$t_{\text{LV\_RISE}}$	LV side rise time for 1.2V LVCMOS	30% to 70%; $C_{\text{LV\_BUS}} = C_{\text{HV\_BUS}} = 50\text{pF}$ ; Pulled up to VIO using $R_{\text{PULV}}$ ;	300		670	ns
	LV side rise time for 1.8V LVCMOS	30% to 70%; $C_{\text{LV\_BUS}} = C_{\text{HV\_BUS}} = 50\text{pF}$ ; Pulled up to VIO using $R_{\text{PULV}}$ ;	300		670	ns
	LV side rise time for 3.3V LVCMOS	30% to 70%; $C_{\text{LV\_BUS}} = C_{\text{HV\_BUS}} = 50\text{pF}$ ; Pulled up to VIO using $R_{\text{PULV}}$ ;	300		670	ns
$t_{\text{HV\_RISE\_50pF}}$	HV side rise time (50pF load)	30% to 70%; $C_{\text{LV\_BUS}} = C_{\text{HV\_BUS}} = 50\text{pF}$ ; VCC = 3.0V; HDMI5V = 5.3V; Pulled up to HDMI5V using $R_{\text{PUHV}}$ ;			225	ns
$t_{\text{HV\_RISE\_750pF}}$	HV side rise time (750pF load)	30% to 70%; $C_{\text{LV\_BUS}} = 50\text{pF}$ ; $C_{\text{HV\_BUS}} = 750\text{pF}$ ; VCC = 3.0V; HDMI5V = 5.3V; Pulled up to HDMI5V using $R_{\text{PUHV}}$ ;			1250	ns

### 5.8 Typical Characteristics

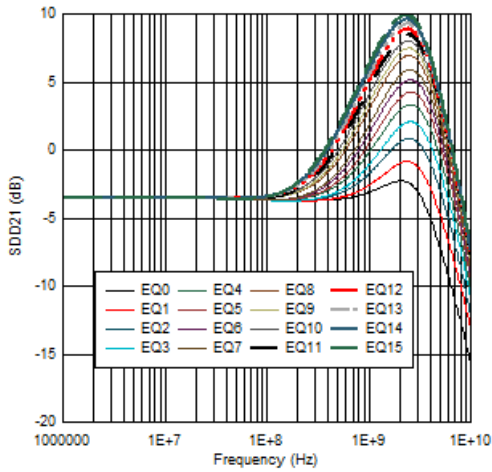

**Figure 5-1. 3Gbps CTLE EQ Curves with GLOBAL\_DCG = 0x2 in Limited Mode**

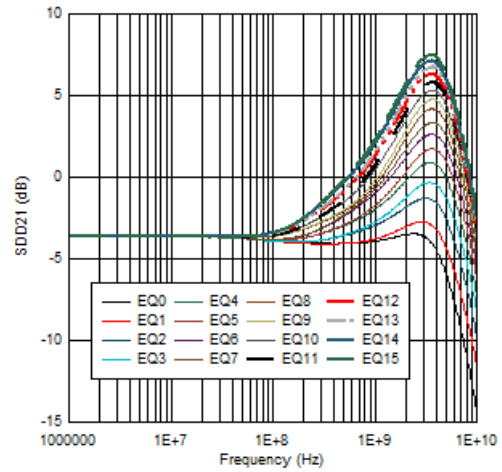

**Figure 5-2. 6Gbps CTLE EQ Curves with GLOBAL\_DCG = 0x2 in Limited Mode**

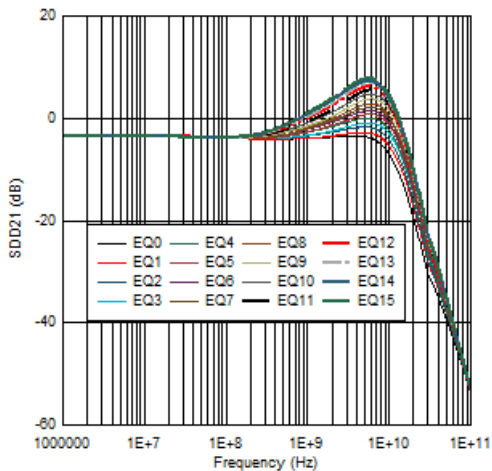

**Figure 5-3. 12Gbps CTLE EQ Curves with GLOBAL\_DCG = 0x2 in Limited Mode**

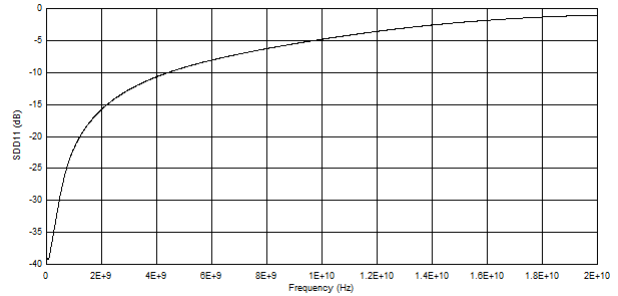

**Figure 5-4. Input Differential Return Loss (SDD11)**

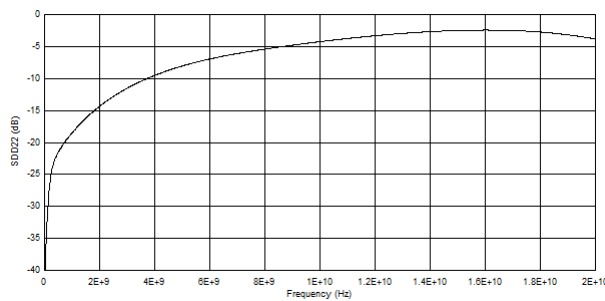

**Figure 5-5. Output Differential Return Loss (SDD22)**

## 6 Parameter Measurement Information

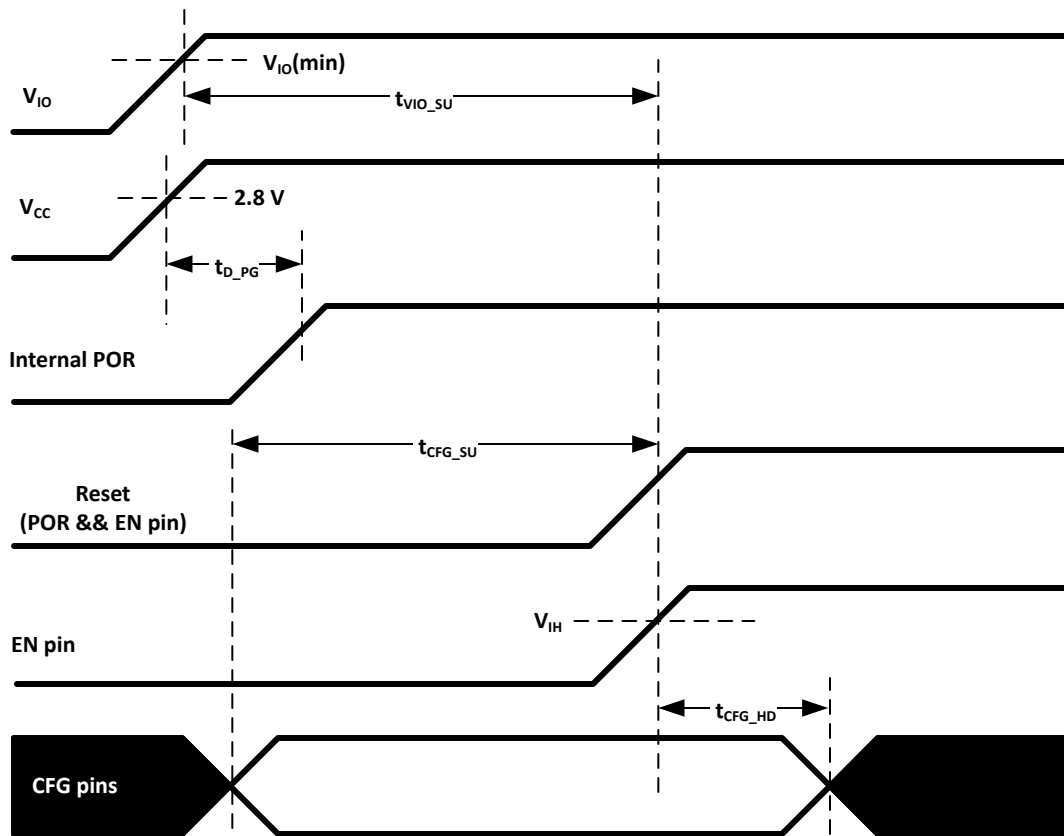

Figure 6-1. Power-On Timing Requirements

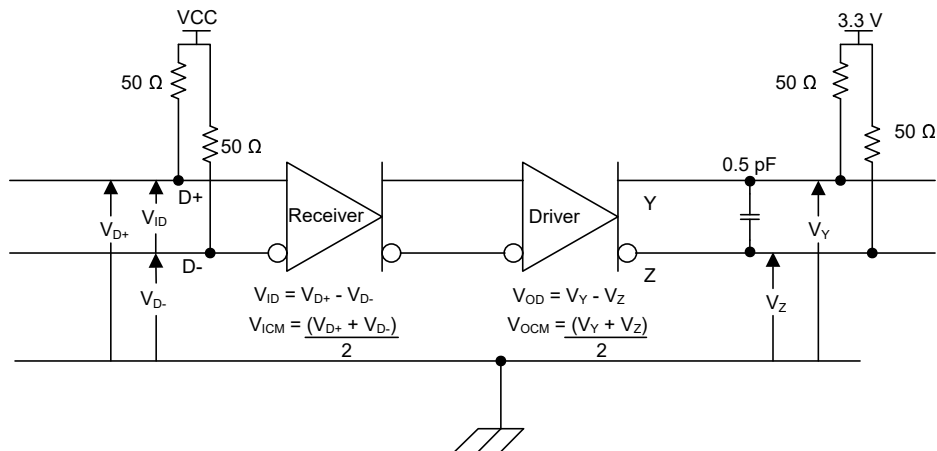
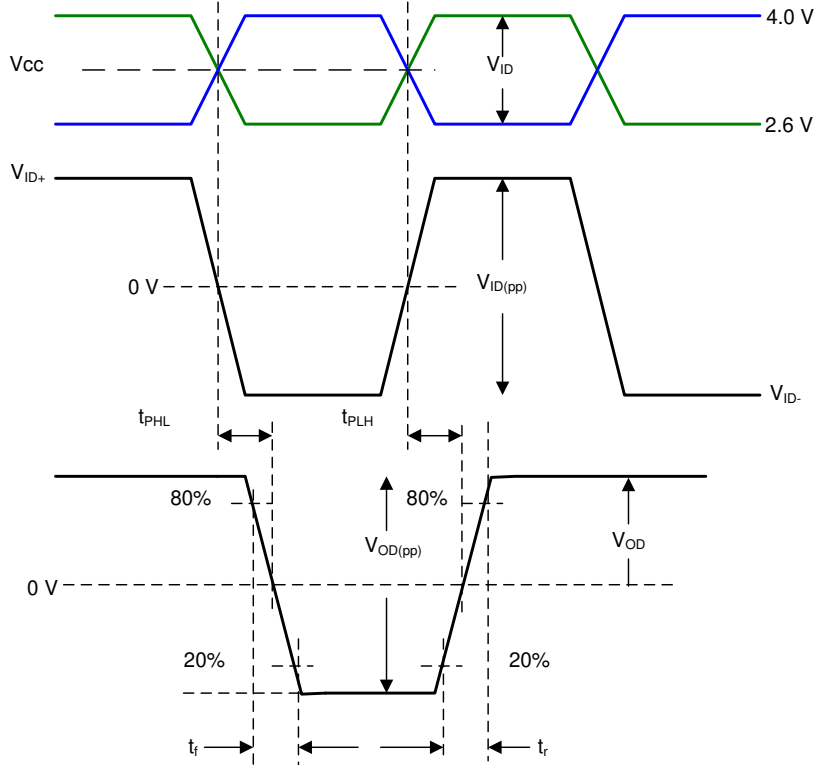
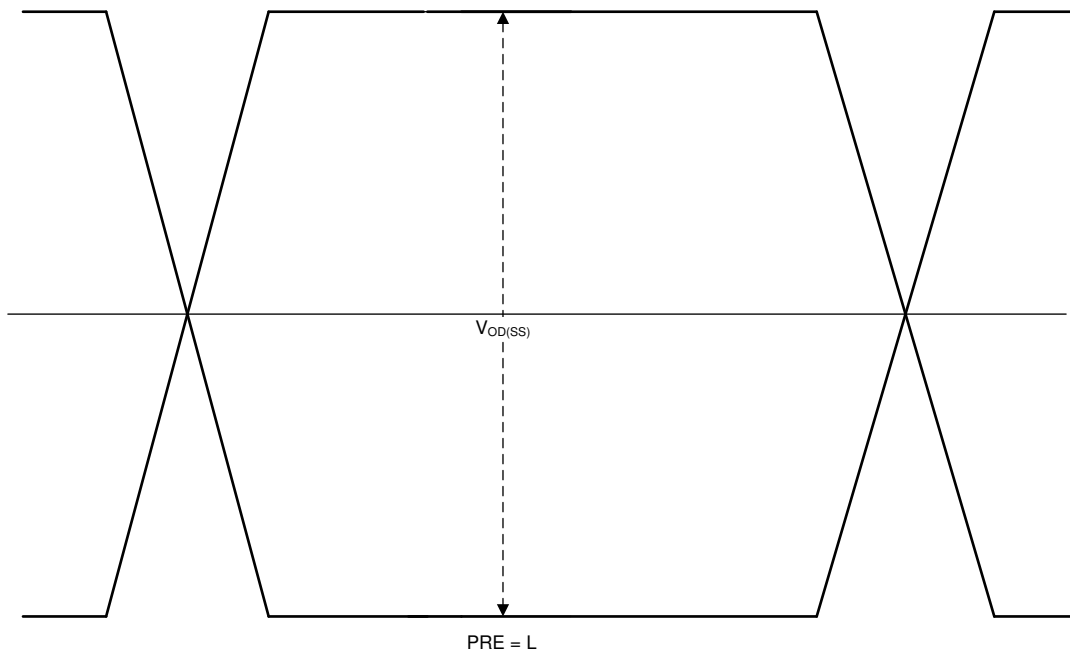

Figure 6-2. TMD5 Main Link Test Circuit



**Figure 6-3. Input or Output Timing Measurements**



**Figure 6-4. Output Differential Waveform**

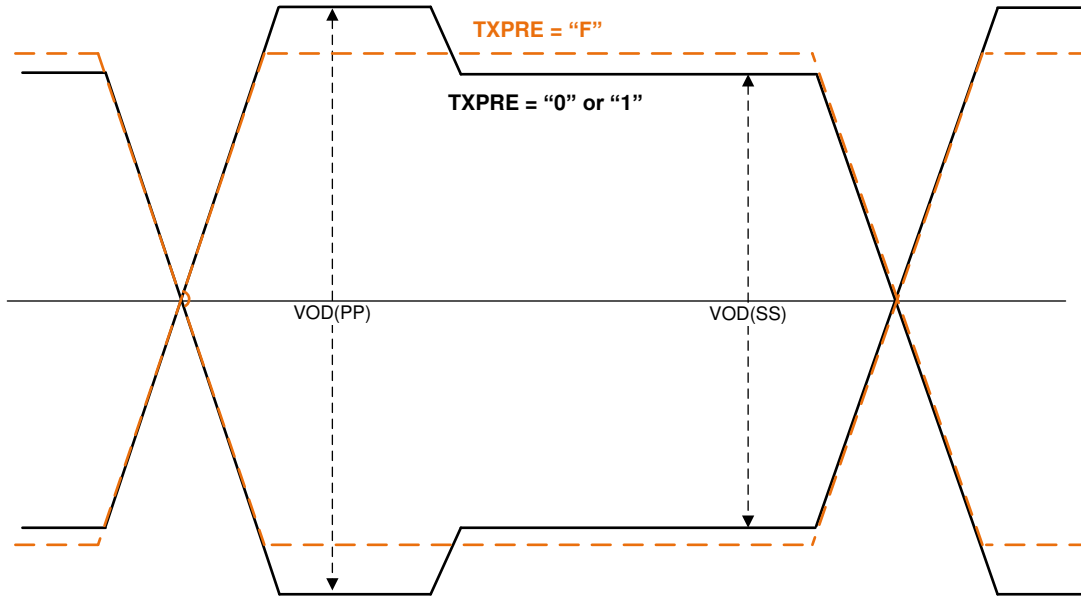

**Figure 6-5. Output Differential Waveform with De-Emphasis**

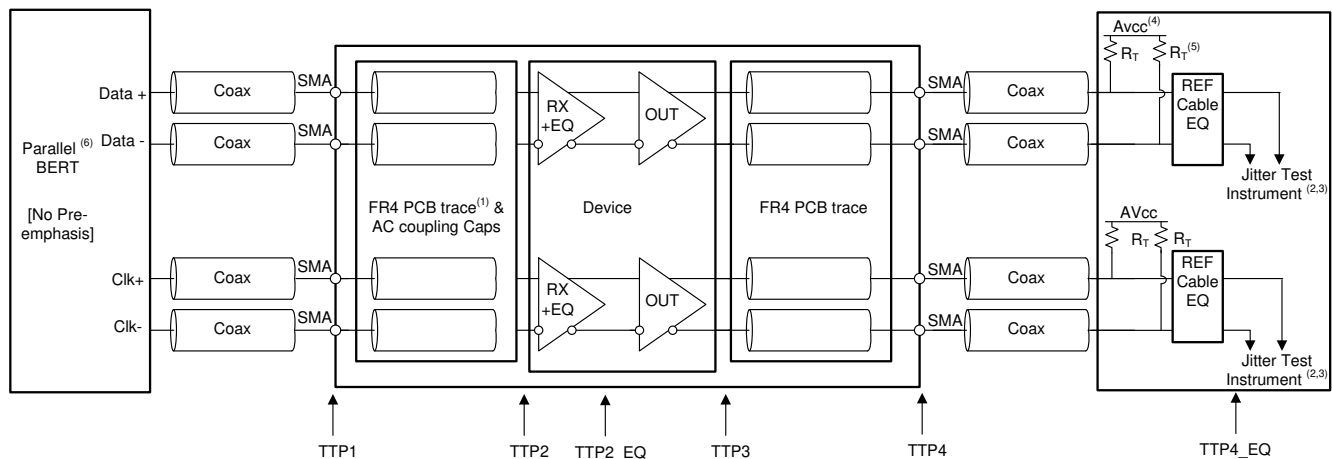

Copyright © 2016, Texas Instruments Incorporated

- (1) The FR4 trace between TTP1 and TTP2 is designed to emulate 1-12" of FR4, AC-coupling capacitor, connector and another 2" of FR4. Trace width – 4 mils. 100 Ω differential impedance.
- (2) All Jitter is measured at a BER of 10<sup>9</sup>. HDMI 2.1 jitter measured at BER 10<sup>-10</sup>.
- (3) Residual jitter reflects the total jitter measured at TTP4 minus the jitter measured at TTP
- (4) AVCC = 3.3V.
- (5) R<sub>T</sub> = 50 Ω.
- (6) For HDMI 1.4 or 2.0, the input signal from parallel Bert does not have any pre-emphasis or de-emphasis. For HDMI 2.1 FRL, the input signal from BERT will have 2.18dB pre-shoot and -3.1dB de-emphasis. Refer to *Recommended Operating Conditions*.

**Figure 6-6. HDMI Output Jitter Measurement**

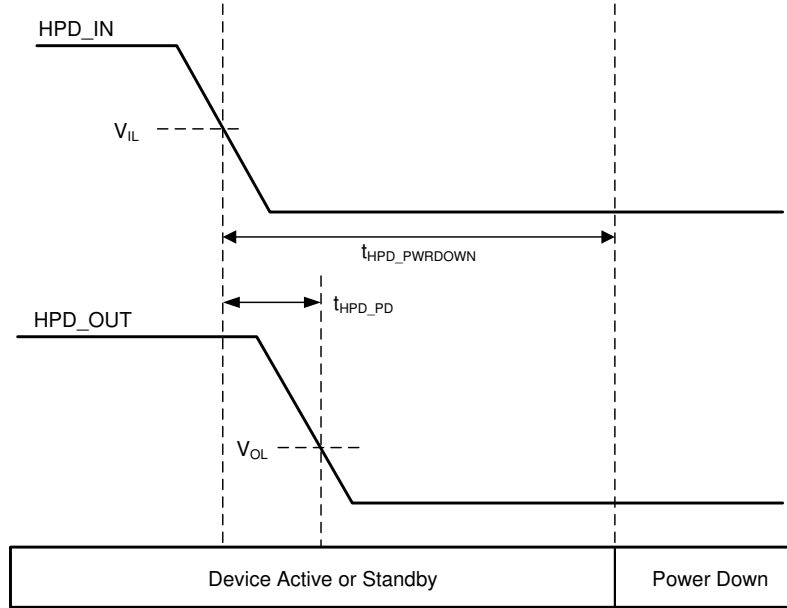

**Figure 6-7. HPD Logic Shutdown and Propagation Timing**

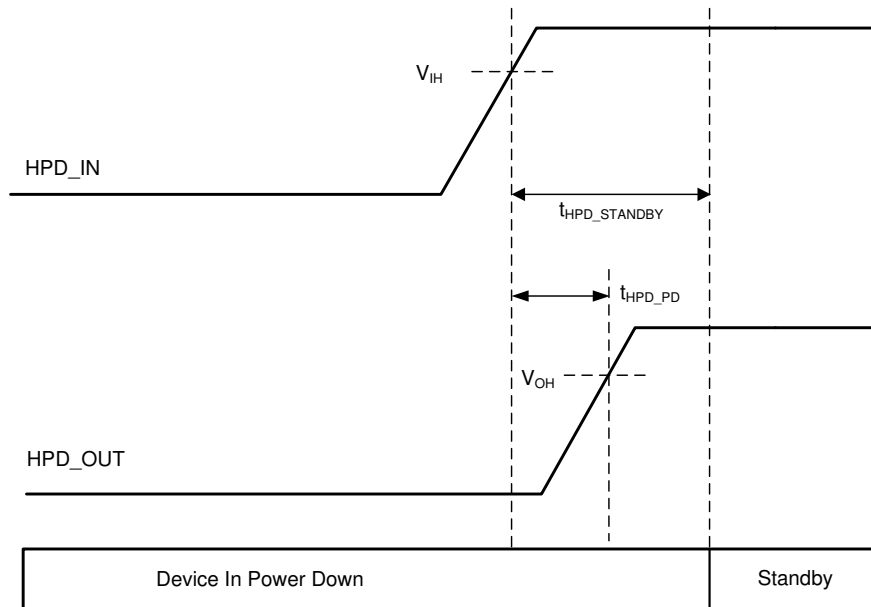

**Figure 6-8. HPD Logic Standby and Propagation Timing**

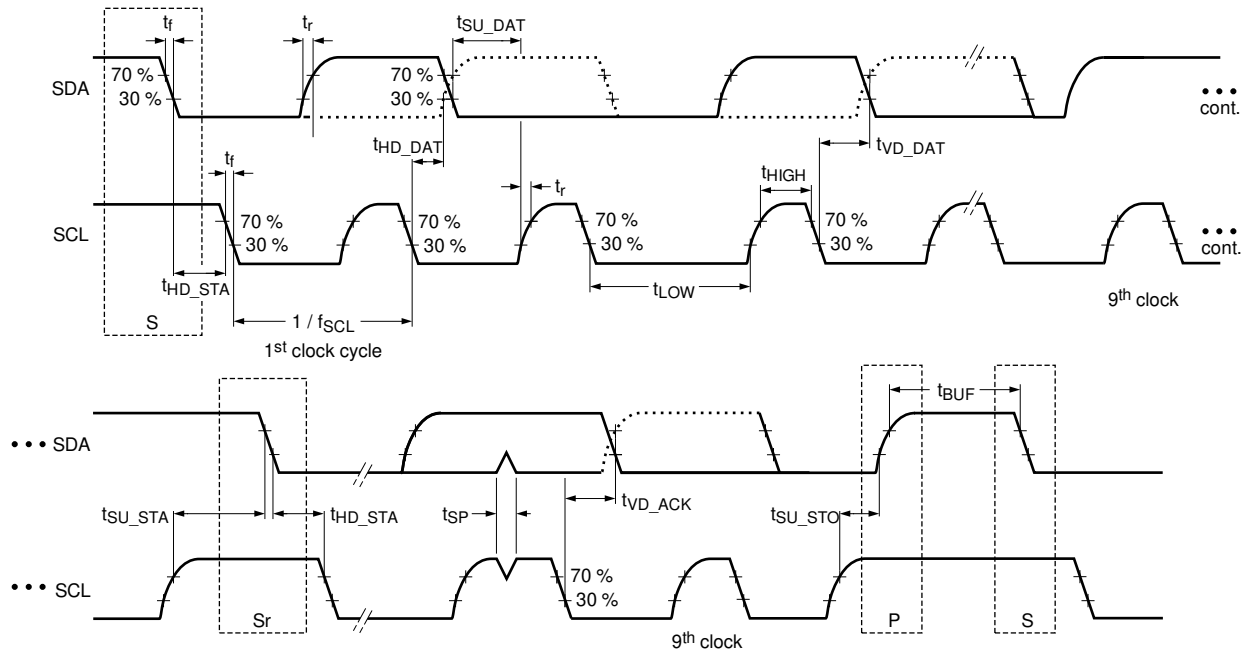

**Figure 6-9. I<sup>2</sup>C SCL and SDA Timing**

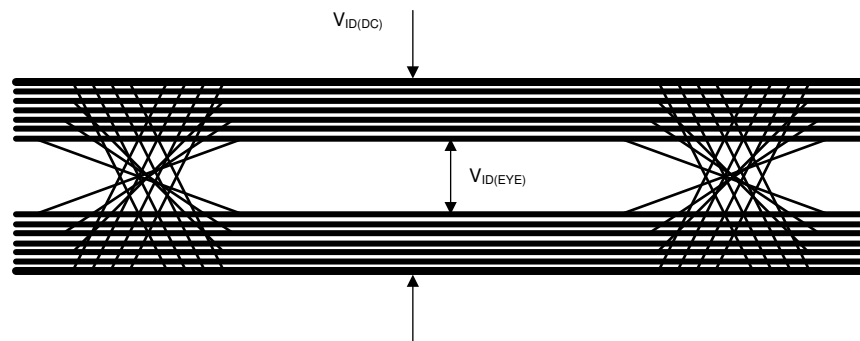

**Figure 6-10.  $V_{ID(DC)}$  and  $V_{ID(EYE)}$**

## 7 Detailed Description

### 7.1 Functional Block Diagram

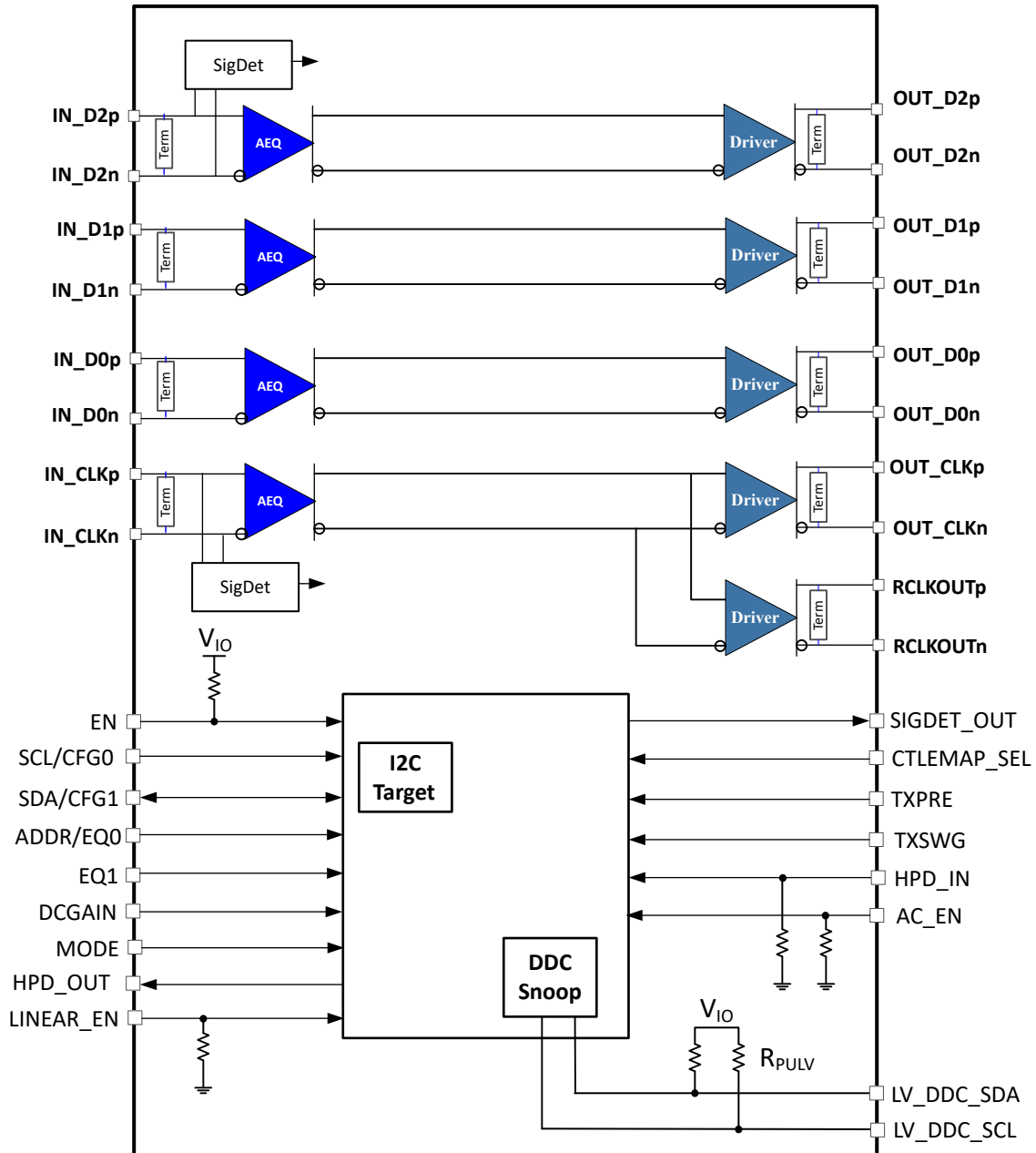

## 7.2 Feature Description

### 7.2.1 4-Level Inputs

The TMDS1204 has 4-level inputs pins that control the receiver equalization gain, transmitter voltage swing, and pre-emphasis, and place TMDS1204 into different modes of operation. These 4-level inputs utilize a resistor divider to help set the 4 valid levels and provide a wider range of control settings. There are internal pull-up and a pull-down resistors. These resistors are combined with the external resistor connection to achieve the desired voltage level.

**Table 7-1. 4-Level Control Pin Settings**

LEVEL	SETTINGS
0	Tie 1kΩ 5% to GND.
R	Tie 20kΩ 5% to GND.
F	Float (leave pin open)
1	Tie 1kΩ 5% to V <sub>CC</sub> .

**Note**

Figure 6-1 shows how all 4-level inputs are latched after the rising edge of the EN pin. After these pins are sampled, the internal pull-up and pull-down resistors will be isolated to save power.

### 7.2.2 I/O Voltage Level Selection

The TMDS1204 supports 1.2V, 1.8V, and 3.3V LVCMOS levels. The VIO pin is used to select which voltage level is used for the following 2-level control pins: LV\_DDC\_SDA, LV\_DDC\_SCL, SCL/CFG0, and SDA/CFG1.

The AC\_EN pin threshold is fixed at 3.3V LVCMOS levels. EN pin threshold is fixed at 1.2V LVCMOS threshold.

**Table 7-2. Selection of LVCMOS Signaling Level**

VIO pin	LVCMOS Signaling Level
VALUE < 1.5V	1.2V
1.5V < VALUE < 2.5V	1.8V
VALUE > 2.5V	3.3V

### 7.2.3 HPD\_OUT

The TMDS1204 will level shift the 5V signaling level present on the HPD\_IN pin to a lower voltage such as 1.8V or 3.3V levels on the HPD\_OUT pin. The HPD\_OUT supports both push-pull and open drain. The default operation is push-pull. Selection between push-pull and open drain is done through the HPDOUT\_SEL register.

Table 7-2 lists how the VIO determines the output level of HPD\_OUT when HPD\_OUT is configured for push-pull operation. Please note push-pull operation is not supported for VIO less than 1.7V.

**Note**

Open-drain operation is only supported when TMDS1204 is configured for I2C mode.

When EN pin is low, the HPD\_OUT pin will be in a high impedance state. It is recommended to have a weak pull-down resistor (such as 220k) on HPD\_OUT.

### 7.2.4 Lane Control

The TMDS1204 has various lane control features. Pin strapping globally controls features like receiver equalization, DC Gain, V<sub>OD</sub> swing, slew rate, and pre-emphasis or de-emphasis. Through I<sup>2</sup>C receiver equalization, transmitter swing, and pre-emphasis for each lane can be independently controlled.

### 7.2.5 Swap

Figure 7-1 shows how TMDS1204 incorporates a swap function which can swap the lanes. The RX EQ, pre-emphasis, termination, and slew configurations will follow the new mapping. This function is supported in pin strap mode as well as when TMDS1204 is configured for I<sup>2</sup>C mode. A register controls the swap function in I<sup>2</sup>C mode.

Table 7-3. Swap Functions

Normal Operation CFG1 pin = L or LANE_SWAP Register is 0h	CFG1 = H or LANE_SWAP Register is 1h
IN_D2 → OUT_D2	IN_CLK → OUT_CLK
IN_D1 → OUT_D1	IN_D0 → OUT_D0
IN_D0 → OUT_D0	IN_D1 → OUT_D1
IN_CLK → OUT_CLK	IN_D2 → OUT_D2

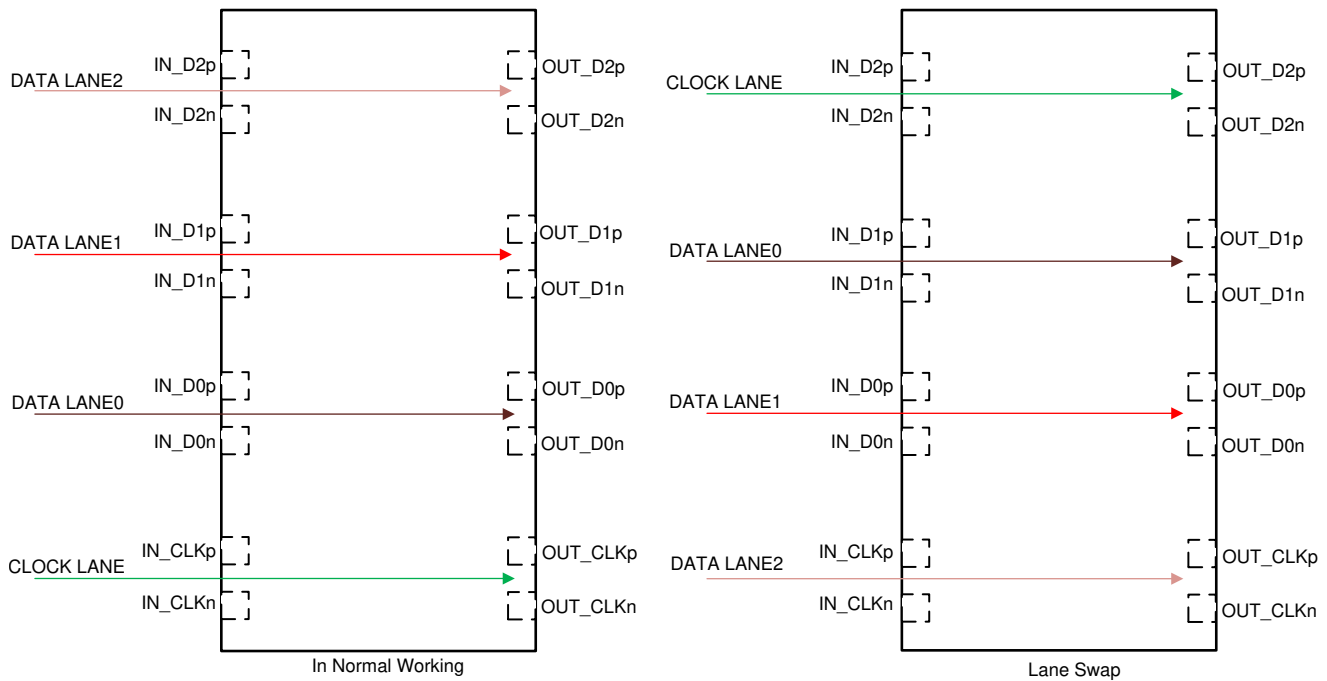

Copyright © 2018, Texas Instruments Incorporated

Figure 7-1. TMDS1204 Swap Function

### 7.2.6 Linear and Limited Redriver

The TMDS1204 supports both linear and limited redriver. Selection between linear and limited can be done from the LINEAR\_EN pin in pin-strap mode or through GLOBAL\_LINR\_EN register in I<sup>2</sup>C mode.

The limited redriver mode will decouple TMDS1204 transmitter's voltage swing, pre-emphasis or de-emphasis, and slew rate from the GPU's transmitter. This allows the GPU to use a lower power TX setting and depends on the TMDS1204 transmitter to meet TX compliance requirements. For source applications, it is recommended to configure TMDS1204 as a limited redriver. It is not recommended to use limited redriver mode in sink applications.

Unlike limited redriver mode, in linear redriver mode the TMDS1204 transmitter's output is not decoupled from the GPU's transmitter. In linear redriver mode, the TMDS1204 transmitter's output is a linear function of its input. The linear redriver mode offers transparency to link training which makes it perfect for HDMI 2.1 applications. For HDMI sink applications, it is recommended to configure TMDS1204 as a linear redriver.

Table 7-4 lists the requirements that the GPU transmitter must meet if linear redriver mode is used in an HDMI 2.1 source application. Linear redriver mode should only be used for HDMI 2.1 data rates. For HDMI 1.4 and 2.0, the TMDS1204 should be configured for limited mode (LINEAR\_EN = "0" or "1").

**Table 7-4. Linear Redriver Mode: GPU TX Requirements for HDMI Source Applications**

GPU TX Parameter	Min	Max	Units
Single-ended TX swing for HDMI 2.1	400	500	mV
TX rise/fall time for 3, 6, 8, 10, and 12Gbps FRL		16	mV/ps

The TMDS1204 in pin-strap mode provides the option to dynamically switch between limited and linear based on the HDMI mode of operation. The feature is enabled by setting LINEAR\_EN pin = "1".

**Table 7-5. Pin-Strap Mode LINEAR\_EN Pin Function**

LINEAR_EN Pin Level	HDMI 1.4, 2.0, or DP	HDMI 2.1 FRL
1	Limited Enabled	Linear Enabled
F	Linear Enabled Recommended for DP and HDMI sink application.	Linear Enabled Recommended for DP and HDMI sink application.
R	Reserved	Reserved
0	Limited Enabled. Recommended for HDMI source application	Limited Enabled Recommended for HDMI source application

### 7.2.7 Main Link Inputs

Each main link input (IN\_D[2:0] and IN\_CLK) is internally biased to 3.3V through approximately 100Ω (50Ω single-ended). When using TMDS1204 in DisplayPort++ applications, external AC-coupling capacitance should be used. When using TMDS1204 in an HDMI application such as in an HDMI monitor, the main link inputs can be DC-coupled to a compliant HDMI transmitter. Each input data channel contains an equalizer to compensate for cable or board losses.

### 7.2.8 Receiver Equalizer

The equalizer is used to clean up inter-symbol interference (ISI) jitter or loss from the bandwidth-limited board traces or cables. TMDS1204 supports fixed receiver equalizer by setting the EQ0 and EQ1 pins or through the I<sup>2</sup>C register. Table 7-6 lists the pin strap settings and EQ values.

The TMDS1204 has three sets of CTLE curves (3Gbps CTLE, 6Gbps CTLE, and 12Gbps CTLE) with each curve having 16 AC gain settings and 3 DC gain settings. Table 7-6 provides details about the 16 AC gain settings with GLOBAL\_DCG = 0x2.

The TMDS1204 in pin-strap mode has three CTLE HDMI Datarate Maps: Map A, Map B, and Map C. Table 7-7 provides details about these maps. The expectation is Map A and C should be used if TMDS1204 is used in a source application and Map B for a sink application.

Table 7-8 lists how the sampled state of the CTLEMAP\_SEL pin determines the default CTLE HDMI Datarate map when the TMDS1204 is configured for pin-strap mode.

In I<sup>2</sup>C mode, the default CTLE (3Gbps, 6Gbps, or 12Gbps) used for each HDMI mode can be controlled from a register.

**Table 7-6. Receiver EQ Settings When GLOBAL\_DCG = 0x2**

EQ Setting <sup>(1)</sup>	RX EQ Level for 3Gbps CTLE (Gain at 1.5GHz – Gain at 10-MHz)	RX EQ Level for 6Gbps CTLE (Gain at 3GHz – Gain at 10-MHz)	RX EQ Level for 12Gbps CTLE (Gain at 6GHz – Gain at 10-MHz)	EQ1 PIN	EQ0 PIN
0 <sup>(2)</sup>	1.0	0.5	0	0	0
1	2.0	1.0	0.8	0	R
2	3.2	2.4	1.8	0	F
3	4.2	3.3	2.7	0	1
4	5.3	4.4	3.7	R	0
5	6.0	5.2	4.4	R	R
6	7.0	6.0	5.0	R	F
7	7.7	6.8	5.8	R	1
8	9.0	7.5	6.5	F	0
9	9.5	8.2	7.5	F	R
10	10.0	8.8	8.3	F	F
11	10.5	9.3	9.1	F	1
12	11.0	10.0	9.8	1	0
13	11.5	10.5	10.3	1	R
14	12.0	11.0	11.0	1	F
15	12.3	11.8	11.6	1	1

- (1) CLK\_EQ, D0\_EQ, D1\_EQ, and D2\_EQ registers determine the receiver EQ setting in I2C mode.  
(2) When CTLEBYP\_EN = 1 and DCGAIN = 0dB, EQ settings 0 will be 0dB due to the CTLE is bypassed.

**Table 7-7. CTLE HDMI Datarate Map A, B, and C**

HDMI Mode	Map A	Map B	Map C
1.4	12Gbps CTLE	3Gbps CTLE	6Gbps CTLE
2.0	12Gbps CTLE	6Gbps CTLE	6Gbps CTLE
3Gbps FRL	12Gbps CTLE	3Gbps CTLE	6Gbps CTLE
6Gbps FRL	12Gbps CTLE	6Gbps CTLE	6Gbps CTLE
8Gbps FRL	12Gbps CTLE	12Gbps CTLE	12Gbps CTLE
10Gbps FRL	12Gbps CTLE	12Gbps CTLE	12Gbps CTLE
12Gbps FRL	12Gbps CTLE	12Gbps CTLE	12Gbps CTLE

**Table 7-8. Pin-strap Mode CTLE HDMI Datarate Mapping**

	Sampled State of CTLEMAP_SEL pin			
	"0"	"R"	"F"	"1"
<b>CTLE HDMI Datarate Map</b>	Map B	Map C	Map B	Map A

**Note**

The clock lane EQ when operating in HDMI 1.4 or 2.0 will use the 3Gbps CTLE and will be set to the zero EQ setting.

**7.2.9 CTLE Bypass**

The TMDS1204 will operate as a buffer when CTLE bypass is enabled. In pin-strap mode, this feature is disabled. In I<sup>2</sup>C mode, this feature is enabled when CTLEBYP\_EN = 1h and GLOBAL\_DCG = 2h. Any lane that has EQ setting of 0h will operate in CTLE bypass.

### 7.2.10 Adaptive Equalization in HDMI 2.1 FRL

The TMDS1204 supports adaptive equalization (AEQ) for HDMI 2.1 FRL. It does not support AEQ for HDMI 1.4 or 2.0. In HDMI 1.4 and HDMI 2.0 modes, TMDS1204 will use the sampled state of the EQ[1:0] pins or value programmed into the register. The AEQ is supported in some pin-strap modes as well as in I<sup>2</sup>C mode. In I<sup>2</sup>C mode, AEQ can be enabled by setting the AEQ\_EN register. The TMDS1204 adaptation algorithm scans through available equalization settings searching for a setting for which the incoming high-speed signal is not over equalized.

The TMDS1204 will perform adaptive equalization when FRL link training begins. It will also re-adapt each time the data rate changes. The adaption will only occur during the TXFFE0 portion of FRL link training when LTP5, LTP6, LTP7, or LTP8 is being received. The TMDS1204 adaption will complete within  $t_{AEQ\_DONE}$  from the time FRL link training begins. If the sink requests additional TXFFE levels (TXFFE1, 2, or 3), then the TMDS1204 will keep its equalizer settings fixed at the value adapted during TXFFE0. If for some reason the FRL link training fails and transitions to legacy mode (HDMI 1.4 or HDMI 2.0), then the EQ [1:0] pins sample the EQ settings that the TMDS1204 switches to if in pin-strap mode or programmed into the register (if in I<sup>2</sup>C mode).

The TMDS1204 will keep OUT\_D[2:0] and OUT\_CLK disabled until after adaptation completes. After adaptation completes, the appropriate lanes will be enabled. In I<sup>2</sup>C mode, this behavior can be overridden by clearing the AEQ\_TX\_DELAY\_EN field.

**Table 7-9. Adaptive Equalization Enable and Disable**

MODE pin level	CTLEMAP_SEL pin level			
	0	R	F	1
0	AEQ disabled	AEQ disabled	AEQ disabled	AEQ disabled
R	AEQ disabled	AEQ disabled	AEQ enabled	AEQ enabled
F	I <sup>2</sup> C register	I <sup>2</sup> C register	I <sup>2</sup> C register	I <sup>2</sup> C register
1	AEQ disabled	AEQ disabled	AEQ enabled	AEQ enabled

#### Note

The AEQ operates only on IN\_D0 pins (pins 12 and 13). The EQ value determined by AEQ will be applied to the other FRL data lanes.

#### 7.2.10.1 HDMI 2.1 TX Compliance Testing with AEQ Enabled

Care must be taken when performing HDMI 2.1 TX compliance testing with AEQ enabled. Because the TMDS1204 will only adapt to LTP5 through 8 during the TXFFE0 part of link training, it is important the test equipment initiate a FRL link training before performing any TX measurements, especially TX eye and jitter measurement. After completion of FRL link training, the test equipment can then switch the current pattern (LTP5, LTP6, LTP7, or LTP8) to the desired test pattern (LTP1, LTP2, LTP3, or LTP4). If the test equipment request LTP1, LTP2, LTP3, or LTP4 before initiating link training, the TMDS1204 will use the sampled state of EQ[1:0] pins.

The following HDMI 2.1 TX tests use LTP5, LTP6, LTP7, and LTP8 as the required pattern for the measurement: HFR1-1, HFR1-2, HFR1-4, HFR1-7, and HFR1-8. If the TMDS1204 AEQ adaption has not completed and instead uses sampled state of EQ[1:0] pins, then it is possible these tests may fail or inaccurately represent system performance.

### 7.2.11 HDMI 2.1 Link Training Compatible Rx EQ

This mode is recommended in source applications in which the GPU is unaware of the TMDS1204 presence and will adjust its transmitter levels (VOD, de-emphasis, and pre-shoot) during HDMI 2.1 FRL link training. This mode is only supported if the TMDS1204 is enabled for limited redriver. [Table 7-10](#) lists the TXFFE levels that this mode assumes the GPU is using.

This feature is supported in I<sup>2</sup>C mode and all pin-strap modes with the exception of MODE = "0".

In HDMI 2.1 with AEQ disabled, the TMDS1204 will initially set the RX EQ based on the EQ0 and EQ1 pins. The pins determine what value will be used when the TXFFE0 is snooped during FRL link training. [Table 7-11](#) lists how TMDS1204 uses the EQ setting for each increase in TXFFE level (TXFFE1, 2, or 3) from the sampled state of the EQ [1:0] pins.

When HDMI 2.1 with AEQ is enabled, the TMDS1204 will adapt during the TXFFE0 portion of FRL link training. [Table 7-11](#) lists how TMDS1204 uses the EQ setting for each increase in TXFFE level (TXFFE1, 2, or 3) from the adapted EQ value.

**Table 7-10. Recommended GPU FRL TXFFE Levels**

GPU FRL TXFFE Levels	Pre-Shoot (dB)	De-Emphasis (dB)
TXFFE0	2.18	-3.10
TXFFE1	2.50	-4.43
TXFFE2	2.92	-6.02
TXFFE3	3.52	-7.96

**Table 7-11. Link Training Compatible RX EQ Adjustments**

Initial EQ Setting from sampled state of EQ[1:0] pins or adapted EQ value	EQ Setting Used for TXFFE1	EQ Setting Used for TXFFE2	EQ Setting Used for TXFFE3
0	0	0	0
1	0	0	0
2	1	0	0
3	1	0	0
4	2	1	0
5	2	1	0
6	3	1	0
7	3	1	0
8	4	2	1
9	5	3	1
10	6	4	1
11	7	5	1
12	8	6	2
13	9	7	3
14	10	8	4
15	11	9	5

### 7.2.12 Input Signal Detect

When standby is enabled and swap is disabled, the TMDS1204 waits for a signal on either IN\_CLK (if HDMI 1.4 or 2.0) or IN\_D2 (if HDMI 2.1). When standby is enabled and swap is enabled, the TMDS1204 looks for a signal on either IN\_CLK (if HDMI 2.1) or IN\_D2 (if HDMI 1.4 or 2.0). The TMDS1204 is fully functional when a signal is detected. If no signal is detected, then the device reenters standby state waiting for a signal again. In the standby state, all of the TMDS outputs are in high-Z status. In both pin-strap mode and I<sup>2</sup>C mode, standby is enabled by default. In I<sup>2</sup>C mode, standby can be disabled by setting the STANDBY\_DISABLE register mode.

#### 7.2.12.1 SIGDET\_OUT Indicator

When standby state is enabled, the TMDS1204 will assert the SIGDET\_OUT pin low whenever the TMDS1204 exits the standby state and will de-assert it when entering power down or standby state. If used, the SIGDET\_OUT requires an external pull-up resistor of 10-kΩ or greater.

## 7.2.13 Main Link Outputs

### 7.2.13.1 Transmitter Bias

The TMDS1204 transmitter supports both external (DC-coupled) and internal bias (AC-coupled) to a receiver. Selection between DC and AC-coupled is done through use of the AC\_EN pin in pin-strap mode and TX\_AC\_EN register in I<sup>2</sup>C mode. The AC\_EN pin informs the TMDS1204 whether or not an external AC-coupling capacitor is present. When AC\_EN is greater than V<sub>IH</sub>, then TMDS1204 transmitters are internally biased to approximately V<sub>CC</sub>. For DisplayPort, HDMI 2.1 FRL AC-coupled, or any other AC-coupled application, the AC\_EN pin should be connected to greater than V<sub>IH</sub> and an external AC-coupling capacitor should be placed on each of the OUT\_D[2:0] pins and the OUT\_CLK pin. If the AC\_EN pin is connected to less than V<sub>IL</sub>, then the AC\_EN pin will inform TMDS1204 that AC\_EN pin is DC-coupled (externally biased) to the far-end HDMI compliant receiver.

#### Note

Figure 7-3 shows that if using AC-coupled TX mode (AC\_EN = high) in an HDMI source application, then an external 499 Ω pull-down to GND must be placed on each OUT pin (OUT\_D2:0p/n and OUT\_CLKp/n) between the AC-coupling capacitor and the HDMI receptacle. The purpose of the 499 Ω resistor is to set the common mode voltage to HDMI compliant levels.

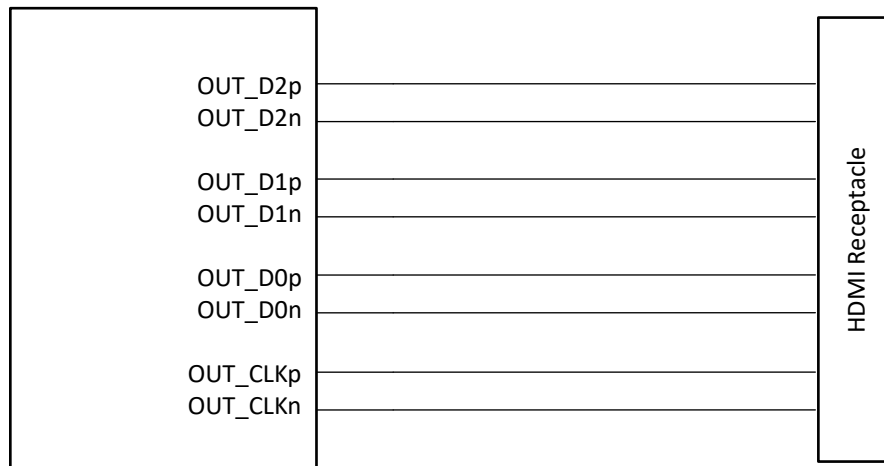

Figure 7-2. DC-Coupled TX in HDMI Source Application (AC\_EN = Low). External ESD is Not Shown.

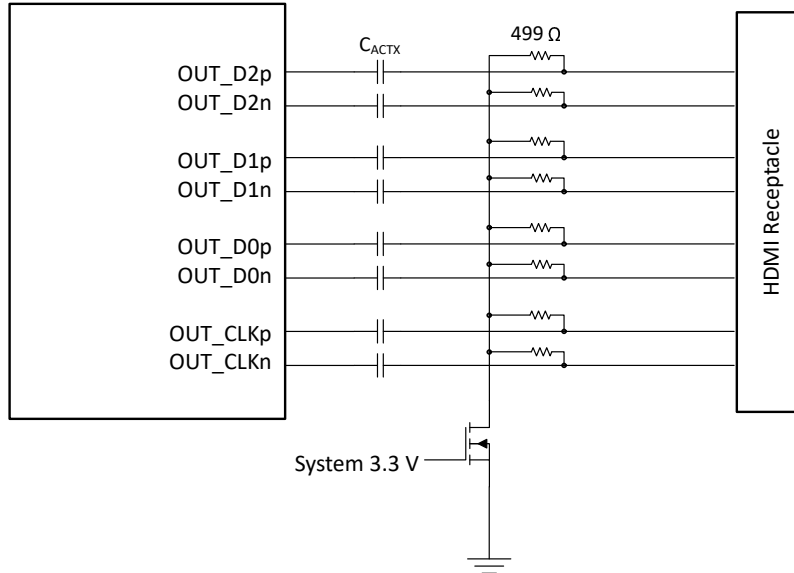

Figure 7-3. AC-Coupled TX in HDMI Source Application (AC\_EN = High). External ESD is Not Shown.

### 7.2.13.2 Transmitter Impedance Control

HDMI 2.0 standards require a source termination impedance approximately 100Ω for data rates > 3.4Gbps. HDMI 1.4b requires no source termination but has a provision for termination for higher data rates greater than 1.65Gbps. Enabling this termination is optional. Table 7-13 lists how the TMDS1204 terminations are controlled automatically when in pin strap mode. Depending on the MODE pin, the CFG0 pin can be used to select the HDMI 1.4 termination between open and 300Ω.

The TMDS1204 supports automatic selection between open and 300Ω termination when operating in HDMI 1.4. In pin-strap mode with CTL0 low, the TMDS1204 will enable open termination when HDMI clock frequency is less than  $f_{\text{HDMI14\_open}}$  and will enable 300Ω termination when HDMI clock frequency is greater than  $f_{\text{HDMI14\_300}}$ . TXTERM\_AUTO\_HDMI14 register controls this feature in I2C mode.

In I<sup>2</sup>C mode, termination is controlled through the registers as provided in Table 7-12.

Table 7-12. Source Termination Control in I2C mode

TX_AC_EN Register	TERM Register	TXTERM_AUTO_HDMI14 Register	Source Termination
0	00	X	None
0	01	X	Parallel $\approx$ 300Ω across P and N
0	10	X	Automatic. HDMI 2.0 or HDM 2.1. parallel $\approx$ 100Ω across P and N
0	10	1	Automatic. HDMI 1.4. parallel $\approx$ 300Ω across P and N
0	10	0	Automatic. HDMI 1.4. No termination if HDMI clock frequency is $\leq f_{\text{HDMI14\_open}}$ .
0	10	0	Automatic. HDMI 1.4. Parallel $\approx$ 300Ω across P and N termination if HDMI clock frequency is $\geq f_{\text{HDMI14\_300}}$ .
0	11	X	Parallel $\approx$ 100Ω across P and N
1	00	X	$\approx$ 150Ω to supply ( $V_{\text{CC}}$ ) on both P and N
1	01	X	$\approx$ 150Ω to supply ( $V_{\text{CC}}$ ) on both P and N
1	10	X	Automatic. $\approx$ 150Ω to supply ( $V_{\text{CC}}$ ) on both P and N for HDMI 1.4. Otherwise $\approx$ 50Ω to supply ( $V_{\text{CC}}$ ) on both P and N.
1	11	X	$\approx$ 50Ω to supply ( $V_{\text{CC}}$ ) on both P and N

**Table 7-13. Automatic Source Termination Control in Pin-Strap Mode**

HDMI Mode	AC_EN pin	Source Termination
HDMI 1.4	0	None or parallel $\approx 300\Omega$ across P and N depending on state of SCL/CFG0 pin
HDMI 2.0	0	Parallel $\approx 100\Omega$ across P and N
HDMI 1.4	1	$\approx 150\Omega$ to supply ( $V_{CC}$ ) on both P and N
HDMI 2.0	1	$\approx 50\Omega$ to supply ( $V_{CC}$ ) on both P and N

**7.2.13.3 TX Slew Rate Control**

The TMDS1204 has the ability to slow down the TMDS output edge rates. In pin-strap mode, the TX slew rate can not be controlled. In I<sup>2</sup>C mode, both clock and data lanes slew rate can be controlled from a register. [Table 7-14](#) lists the supported settings for each slew rate register based on HDMI data rate. The TMDS1204 must be configured in limited redriver mode to control the TX slew rate.

**Table 7-14. I<sup>2</sup>C Mode TX Slew Register Supported Settings**

HDMI Datarate	SLEW_CLK Register	SLEW_3G Register	SLEW_6G Register	SLEW_8G10G12G Register
HDMI 1.4	3'b000 through 3'b011	3'b010 through 3'b101	N/A	N/A
HDMI 2.0	3'b000 through 3'b011	N/A	3'b011 through 3'b110	N/A
HDMI 2.1 3Gbps FRL	N/A	3'b010 through 3'b101	N/A	N/A
HDMI 2.1 6Gbps FRL	N/A	N/A	3'b011 through 3'b110	N/A
HDMI 2.1 8Gbps FRL	N/A	N/A	N/A	3'b100 through 3'b111
HDMI 2.1 10Gbps FRL	N/A	N/A	N/A	3'b110 through 3'b111
HDMI 2.1 12Gbps FRL	N/A	N/A	N/A	3'b111

**7.2.13.4 TX Pre-Emphasis and De-Emphasis Control**

The TMDS1204 provides pre-emphasis and de-emphasis on the data lanes allowing the output signal pre-conditioning to offset interconnect losses between the TMDS1204 outputs and a TMDS receiver. Pre-emphasis and de-emphasis is not implemented on the clock lane unless the TMDS1204 is in HDMI 2.1 FRL mode and at which time the clock lane becomes a data lane. There are two methods to implement pre-emphasis, pin strapping or through I<sup>2</sup>C programming. TX pre-emphasis and de-emphasis control is only supported in limited mode.

When using pin strap mode, the TXPRE pin controls four different global pre-emphasis and de-emphasis values for all data lanes when TMDS1204 is operating in HDMI 1.4 or HDMI 2.0. [Table 7-15](#) lists these pre-emphasis and de-emphasis values. In HDMI 2.1 FRL mode, the de-emphasis value used is based on the DDC TXFFE snooped value. [Table 7-16](#) lists how the TMDS1204 uses the de-emphasis level for each TX FFE level.

**Table 7-15. Pin-Strap TXPRE Pin Function**

TXPRE pin	LINEAR_EN pin = "0"			LINEAR_EN pin = "F" or "1"	LINEAR_EN pin = "R"
	HDMI 1.4 or HDMI 2.0	HDMI 2.1 FRL TXFF0 Level	AEQ ADJUSTMENT	AEQ ADJUSTMENT	AEQ ADJUSTMENT
0	3.5dB pre-emphasis	Refer to <a href="#">Table 7-16</a> .	0	+1	0
R	-2.5dB de-emphasis	Refer to <a href="#">Table 7-16</a> .	0	+4	0
F	0dB	Refer to <a href="#">Table 7-16</a> .	0	0	0
1	6.0dB pre-emphasis	Refer to <a href="#">Table 7-16</a>	0	+2	0

**Table 7-16. HDMI 2.1 FRL TX FFE Levels**

FRL TX FFE Snooped Level	De-Emphasis (dB)
TXFFE0	-2.5

**Table 7-16. HDMI 2.1 FRL TX FFE Levels (continued)**

FRL TX FFE Snooped Level	De-Emphasis (dB)
TXFFE1	-3.5
TXFFE2	-3.7
TXFFE3	-4.6

### 7.2.13.5 TX Swing Control

The TMDS1204 transmitter swing level can be adjusted in both pin strap and I<sup>2</sup>C mode. In I<sup>2</sup>C mode, TX swing settings are controlled independently for each lane (both clock and data) through registers.

In I<sup>2</sup>C mode, the TX swing used when operating in HDMI 1.4 and HDMI 2.0 can be independently controlled through HDMI14\_VOD and HDMI20\_VOD registers.

Table 7-17 lists how the TXSWG pin adjusts the default 1000mV swing in pin strap mode with limited redeliver mode enabled. In HDMI 1.4 the TXSWG controls the swing for both the data and clock lanes. In HDMI 2.0, the TXSWG pin controls the data lanes while the clock lane will remain at the default value. In HDMI 2.1, the TXSWG pin controls data and clock lanes.

In pin-strap mode with linear enabled, the linearity range is fixed at the highest level (1200mVpp) and therefore TXSWG pin is not used. In I<sup>2</sup>C mode, the linearity range can be adjusted from a register.

**Table 7-17. Pin Strap TXSWG Control**

TXSWG pin	Limited Mode for HDMI 1.4	Limited Mode for HDMI 2.0	Limited Mode for HDMI 2.1	Linear Mode
0	Default (1000mVpp)	Default (1000mVpp)	Default + 10%	1200mVpp
R	Default – 5%	Default – 5%	Default – 5%	1200mVpp
F	Default (1000mVpp)	Default (1000mVpp)	Default (1000mVpp)	1200mVpp
1	Default (1000mVpp)	Default + 5%	Default + 5%	1200mVpp

### 7.2.13.6 Fan-out Buffer

In some applications the HDMI clock and data must be on separate paths. The TMDS1204 implements a fan-out buffer feature to support such applications. When the fan-out buffer feature is enabled, the TMDS1204 will output the HDMI clock on RCLKOUTp/n when operating in HDMI 1.4 or HDMI 2.0. The OUT\_CLKp/n will be disabled. When operating in HDMI 2.1 FRL mode, the TMDS1204 will output FRL data3 on OUT\_CLKp/n. RCLKOUTp/n will be disabled.

The feature is enabled in pin-strap mode when MODE pin = "R" or it can be enable through FANOUT\_EN register when TMDS1204 is configured for I<sup>2</sup>C mode.

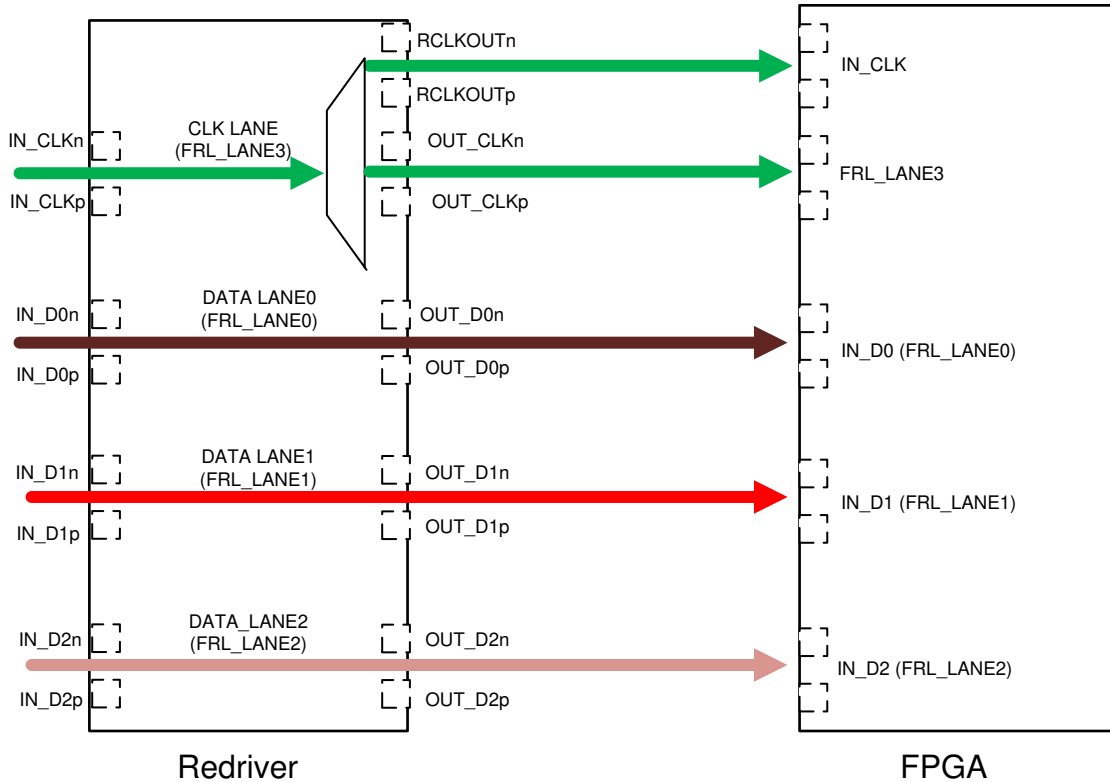

**Figure 7-4. Fan-Out Buffer**

**Note**

Fan-out buffer feature will be disabled if SWAP is enabled.

**7.2.14 HDMI DDC Capacitance**

The HDMI specification limits the DDC bus capacitance to  $\leq 50$ -pF for both an HDMI source and sink. Therefore, care must be taken to make sure the total capacitance of all components (TMDS1204, FR4 trace, ESD, source, and sink) is less than 50-pF.

If implementing a DDC level shifter using pass gates, then the total capacitance will include all components between source or sink and the HDMI receptacle. These components include and are not limited to Source or Sink, the FR4 trace, ESD components, and TMDS1204.

**Note**

Trace capacitance can be in the range of 2 to 5-pF per inch. A general rule is a 50Ω FR4 trace will be around 3.3-pF per inch.

**7.2.15 DisplayPort**

The TMDS1204 supports DisplayPort at data rates up to 8.1Gbps (HBR3) when configured for either pin-strap and I<sup>2</sup>C mode. In pin-strap mode, DisplayPort mode is enabled as provided in [Table 7-18](#). In I<sup>2</sup>C mode, DisplayPort mode is enabled when FRL\_RATE field (offset 0x31) is programmed to 0x6, RATE\_SNOOP\_CTRL (offset 0xA bit 2) is disabled, and TXFFE\_SNOOP\_CTL (offset 0xA bits 1:0) is disabled.

**Note**

The TMDS1204 must be configured as a linear redriver when enabled for DisplayPort mode. The linear range should be programmed to highest level (Dx\_VOD = 0x3 and CLK\_VOD = 0x3). The TMDS1204 TX termination must be set to 100Ω (TERM = 0x3) and TX bias must be set to ac-coupled (TX\_AC\_EN = 0x1).

**7.3 Device Functional Modes**

**7.3.1 MODE Control**

The MODE pin provides four modes of operation. There are three pin-strap modes and one I<sup>2</sup>C mode. In all three pin strap modes, DDC snooping feature is enabled. In I<sup>2</sup>C mode, DDC snoop feature is enabled by default but can be disabled by a register.

**7.3.1.1 I<sup>2</sup>C Mode (MODE = "F")**

In I<sup>2</sup>C mode, all settings of the TMDS1204 can be controlled through the registers. The TMDS1204 7-bit I2C address is determined by the ADDR/EQ0 pin. All other 4-level and 2-level pins are not used in I<sup>2</sup>C mode since the functions exist in a register. The SCL/CFG0 pin will function as the I<sup>2</sup>C clock and the SDA/CFG1 pin will function as the I<sup>2</sup>C data.

The TMDS1204 defaults to power down in I<sup>2</sup>C mode. Upon completion of initialization of the TMDS1204, software must clear the PD\_EN field to exit the power down state. The HPD\_OUT pin will be asserted low while the PD\_EN register is set.

The TMDS1204 supports 1.2V, 1.8V, and 3.3V I<sup>2</sup>C signaling levels. Selection of 1.2V, 1.8V, or 3.3V is determined by the VIO pin as provided in [Table 7-2](#).

**7.3.1.2 Pin Strap Modes**

[Table 7-18](#) and [Table 7-19](#) lists how the SCL/CFG0 and the SDA/CFG1 pins will be used to control the HDMI 1.4 termination, lane SWAP function, and the DisplayPort mode in pin-strap mode.

**Table 7-18. SCL/CFG0 Pin in Pin-Strap Mode**

SCL/CFG0 Pin	AC_EN Pin	TMDS1204 Function
0	0	HDMI 1.4 termination is open if HDMI clock frequency $\leq f_{\text{HDMI14\_open}}$
0	0	HDMI 1.4 termination is $\approx 300\Omega$ if HDMI clock frequency $\geq f_{\text{HDMI14\_300}}$
1	0	HDMI 1.4 termination is $\approx 300\Omega$
0	1	Normal HDMI. Function determined by MODE pin.
1	1	DisplayPort mode. DDC snoop disabled. All four lanes enabled when HPD_IN is high. 12Gbps CTLE used.

**Table 7-19. SDA/CFG1 Pin in Pin-Strap Mode**

SDA/CFG1 Pin	TMDS1204 Function
0	Normal Lane ordering
1	Lane Swap enabled

**Note**

The SCL/CFG0 is the only two-level pin that is continuously sampled in pin-strap mode. AC\_EN, HPDOUT\_SEL, and SDA/CFG1 will not be continuously sampled in pin-strap mode unless indicated otherwise.

The TMDS1204 must be configured as a linear redriver when operating in DisplayPort mode.

### 7.3.1.2.1 Pin-Strap: HDMI 1.4 and HDMI 2.0 Functional Description

The TMDS1204 will always use the sampled state of EQ[1:0] pins when operating in either HDMI 1.4 and HDMI 2.0. The amount of EQ applied is determined by the CTLE Map used (for more information, refer to [Section 7.2.8](#)).

If TMDS1204 is configured for limited redriver mode, then the OUT\_D[2:0] and OUT\_CLKP/N levels will be fixed based on the sampled state of TXSWG pin ([Table 7-17](#) provides more information) and TXPRE pin ([Table 7-15](#) provides more information).

If TMDS1204 is configured for linear redriver mode, then OUT\_D[2:0] and OUT\_CLK will be a linear function of the input signals.

---

#### Note

In source application, it is recommended to use limited redriver mode for both HDMI 1.4 and HDMI 2.0.

---

### 7.3.1.2.2 Pin-Strap HDMI 2.1 Function (MODE = "0"): Fixed Rx EQ

In this mode, the TMDS1204 will operate with a fixed RX EQ based on the value set by EQ0 and EQ1 pins.

As listed in [Table 7-16](#), the outputs will be fixed to TXFFE0 in HDMI 2.1 FRL with limited redriver enabled. These outputs will not change based on the snooped value of TXFFE. This configuration is intended to be used in sink applications where the channel between sink and TMDS1204 is fixed.

---

#### Note

Adaptive EQ is not supported in this mode (for more information refer to [Section 7.2.10](#)). Link Training Compatible Rx EQ is not supported in this mode (for more information, refer to [Section 7.2.11](#)).

---

### 7.3.1.2.3 Pin-Strap HDMI 2.1 Function (Mode = "1"): Flexible Rx EQ

In this mode, the TMDS1204 supports both Adaptive EQ (AEQ) (for more information, refer to [Section 7.2.10](#)) and Link Training Compatible Rx EQ (for more information, refer to [Section 7.2.11](#)).

If TMDS1204 is configured for limited redriver mode, the OUT\_D[2:0] and OUT\_CLK VOD level will be fixed based on the sampled state of TXSWG ([Table 7-17](#) provides more information). As provided in [Table 7-16](#), the outputs will be fixed to TXFFE0 in HDMI 2.1 FRL. These outputs will not change based on the snooped value of TXFFE.

### 7.3.1.2.4 Pin-Strap HDMI 2.1 Function (Mode = "R"): Flexible Rx EQ and Fan-Out Buffer

This pin strap mode is the same as MODE = "1" except that the Fan-Out buffer is supported.

As shown in [Figure 7-4](#), the fan-out buffer feature is supported in this mode. The TMDS1204 will output HDMI clock on RCLKOUTp/n when operating in HDMI 1.4 and HDMI 2.0, and OUT\_CLKp/n will be disabled in HDMI 1.4 and HDMI 2.0. In HDMI 2.1 FRL mode, the RCLKOUTp/n will be disabled and FRL data lane 3 will be the output through the TMDS1204 clock lane.

---

#### Note

Fan-out buffer feature will be disabled if SWAP is enabled. In this pin strap mode, it is recommended to configure TMDS1204 in linear redriver mode.

---

## 7.3.2 DDC Snoop Feature

As part of discovery the source reads the sink E-EDID information to understand the sink's capabilities. Part of this read is HDMI Forum Vendor Specific Data Block (HF-VSDB) located at target address 0xA8. From the LV\_DDC\_SDA and LV\_DDC\_SCL pins, the TMDS1204 DDC snoop function will monitor both reads and writes to specific offsets of the Status and Control Data Channel Structure (SCDCS) located within the HF-VSDB. The following SCDCS offsets are monitored: Update Flags at offset 10h, TMDS Configuration at offset 20h, Sink

Configuration at offset 31h, Source Test Configuration at offset 35h, and Status Flags located at offsets 41h and 42h. The DDC snoop function resides on the LV\_DDC\_SDA and LV\_DDC\_SCL pins.

The TMDS1204 has similar SCDCS registers within its register space. Through TMDS1204 local I<sup>2</sup>C interface, external microprocessor can control TMDS1204 to perform all the necessary functions required for each HDMI type.

### 7.3.2.1 HDMI Type

Table 7-20 lists the TMDS1204 monitors offsets 20h and 31h to determine HDMI type as either HDMI 1.4, HDMI 2.0, or HDMI 2.1 FRL.

**Table 7-20. HDMI Type Selection**

HDMI Type	TMDS_CLK_RATIO SCDCS Offset 20h[1]	FRL_RATE SCDCS Offset 31h[3:0]
HDMI 1.4 (TMDS x10)	0	0h
HDMI 2.0 (TMDS x40)	1	0h
HDMI 2.1 FRL	X	Not 0h

#### Note

TMDS1204 will default to HDMI 1.4 following a power-on reset or whenever it enters the power down state. Upon exiting standby, the TMDS1204 will hold data rate value (HDMI 1.4, 2.0, or 2.1) prior to entering the standby.

### 7.3.2.2 HDMI 2.1 FRL Snoop

In HDMI 2.1 FRL mode, the TMDS1204 monitors offset 31h, 35h, 41h, and 42h. Each offset contains information that the TMDS1204 uses during FRL link training or during TX compliance testing.

Offset 31h contains FRL lane count (3 or 4 lanes), data rate (3, 6, 8, 10, or 12Gbps), and maximum TXFFE levels supported. TMDS1204 enables the appropriate number of lanes based on the lane count. The TMDS1204 uses the data rate information to determine the duration of the TXFFE de-emphasis. The maximum number of supported TXFFE levels sets the number of TXFFE levels TMDS1204 uses during FRL link training. Table 7-16 lists the TMDS1204 does support all four possible TXFFE levels (TXFFE0 through TXFFE3).

Values snooped from offset 35h is used by TMDS1204 during TX FFE compliance testing.

### 7.3.3 Low Power States

The TMDS1204 has two low power states: Power Down and Standby. Table 7-21 lists both lower power states. Power down is entered when HPD\_IN is low for  $t_{HPD\_PWRDOWN}$  or in I<sup>2</sup>C if PD\_EN bit is set. Power down is also entered when the EN pin is low. The TMDS1204 will exit power down to the standby state when HPD\_IN is high for  $t_{HPD\_STANDBY}$ .

The TMDS1204 implements a two stage standby power process when HPD\_IN is high.

Stage 1: if there is no signal (electrical idle) on the IN\_CLK lane, and if HDMI 1.4/2.0 or IN\_D2 if HDMI 2.1, then the TMDS1204 will enter Standby State within  $t_{STANDBY\_ENTRY}$ .

Stage 2: if a signal is detected which last longer than  $t_{SIGDET\_DB}$ , then TMDS1204 will declare a valid signal and exit standby within  $t_{STANDY\_EXIT}$ .

- If a signal is detected, then the TMDS1204 will go into normal active operation and signals present at IN\_CLK and IN\_D[2:0] inputs will be passed through to the OUT\_CLK and OUT\_D[2:0] outputs.
- If it is determined that no signal is present, then the TMDS1204 will reenter stage 1.

The TMDS1204 will exit standby state and immediately enter active state if LTP1, LTP2, LTP3, or LTP4 is snooped while monitoring status flags at SCDCS offset 41h or 42h.

The TMDS1204 will exit normal operation and return to the standby state within  $t_{STANDBY\_ENTRY}$  anytime electrical idle is detected.

**Table 7-21. Power States**

EN pin	INPUTS					STATUS					
	HPD_IN pin	STANDBY_DISABLE register	HPD_PWRDN_DISABLE register	PD_EN register	HDMI 1.4/2.0: IN_CLK pin HDMI 2.1: IN_D2 pins	HPD_OUT pin	IN_Dx pins	SDA/SCL	OUT_Dx OUT_CLK	DDC	State
L	X	X	X	X	X	High-Z	High-Z	Disabled	High-Z	Disabled	Power Down State
H	L	X	0	0	X	L	High-Z	Active	High-Z	Disabled	Power Down State
H	X	X	X	1	X	L	High-Z	Active	High-Z	Disabled	Power Down State
H	H	1	X	0	X	HPD_IN	All RX Active	Active	TX Active	Active	Normal operation
H	X	1	1	0	X	H	All RX Active	Active	TX Active	Active	Normal operation
H	H	0	X	0	No signal	HPD_IN	HDMI 1.4/2.0: IN_CLK Active HDMI 2.1: IN_D2 Active	Active	High-Z	Active	Standby State (Squelch waiting)
H	H	0	X	0	Valid signal detected	HPD_IN	All RX Active	Active	TX Active	Active	Normal operation
H	X	0	1	0	No signal	H	HDMI 1.4/2.0: IN_CLK Active HDMI 2.1: IN_D2 Active	Active	High-Z	Active	Standby State (Squelch waiting)
H	X	0	1	0	Valid signal detected	H	All RX Active	Active	TX Active	Active	Normal operation

## 7.4 Programming

### 7.4.1 Pseudocode Examples

These are examples of configuring TMDS1204 when it is configured for I2C mode.

#### 7.4.1.1 HDMI 2.1 Source Example with DDC Snoop Disabled and DDC Buffer Disabled

When using an external discrete DDC buffer with snooping disabled, this example can be used. In this example, adaptive EQ for HDMI 2.1 is disabled. Also, this example assumes the source only wants to support TXFFE0 level when operating in HDMI 2.1 FRL mode.

This example will initialize the following:

- Limited redriver mode with DC-coupled output
- TX slew rate for each data rate
- CTLE used for each data rate

```
// (address, data)
// Initial power-on configuration.
(0x0A, 0x05), // Rate snoop disabled and TXFFE controlled by 35h, 41h, and 42h
(0x0B, 0x23), // 3G and 6G tx slew rate control
(0x0C, 0x70), // HDMI clock and 8G10G12G TX slew rate control
(0x0E, 0x97), // HDMI 1.4, 2.0 and 2.1 CTLE selection
(0x11, 0x00), // Disable all four lanes.
(0x09, 0x00), // Take out of PD state. Should be done after initialization is complete.

// Selection between HDMI modes (1.4, 2.0, and 2.1)
switch (HDMI_MODE) {
    case 'HDMI14_165' : // HDMI 1.4 configuration for less than 1.65Gbps
        (0x11, 0x00), // Disable all four lanes.
        (0x0D, 0x20), // Limited mode, DC-coupled TX, 0dB DCG, Term open, disable CTLE bypass
        (0x12, 0x03), // Clock lane VOD and TXFFE
        (0x13, 0x00), // Clock lane EQ.
        (0x14, 0x03), // D0 lane VOD and TXFFE.
        (0x15, 0x0Y), // D0 lane EQ. Set "Y" to desired value.
        (0x16, 0x03), // D1 lane VOD and TXFFE.
        (0x17, 0x0Y), // D1 lane EQ. Set "Y" to desired value.
        (0x18, 0x03), // D2 lane VOD and TXFFE.
        (0x19, 0x0Y), // D2 lane EQ. Set "Y" to desired value.
        (0x20, 0x00), // Clear TMDS_CLK_RATIO
        (0x31, 0x00), // Disable FRL
        (0x11, 0x0F), // Enable all four lanes.
        break;
    case 'HDMI14_340' : // HDMI 1.4 configuration for greater than 1.65Gbps
        (0x11, 0x00), // Disable all four lanes.
        (0x0D, 0x21), // Limited mode, DC-coupled TX, 0dB DCG, Term 300, disable CTLE bypass
        (0x12, 0x03), // Clock lane VOD and TXFFE
        (0x13, 0x00), // Clock lane EQ.
        (0x14, 0x03), // D0 lane VOD and TXFFE.
        (0x15, 0x0Y), // D0 lane EQ. Set "Y" to desired value.
        (0x16, 0x03), // D1 lane VOD and TXFFE.
        (0x17, 0x0Y), // D1 lane EQ. Set "Y" to desired value.
        (0x18, 0x03), // D2 lane VOD and TXFFE.
        (0x19, 0x0Y), // D2 lane EQ. Set "Y" to desired value.
        (0x20, 0x00), // Clear TMDS_CLK_RATIO
        (0x31, 0x00), // Disable FRL
        (0x11, 0x0F), // Enable all four lanes.
        break;
    case 'HDMI20' : // HDMI 2.0 configuration
        (0x11, 0x00), // Disable all four lanes.
        (0x0D, 0x23), // Limited mode, DC-coupled TX, 0dB DCG, Term 100, disable CTLE bypass
        (0x12, 0x03), // Clock lane VOD and TXFFE
        (0x13, 0x00), // Clock lane EQ.
        (0x14, 0x03), // D0 lane VOD and TXFFE.
        (0x15, 0x0Y), // D0 lane EQ. Set "Y" to desired value.
        (0x16, 0x03), // D1 lane VOD and TXFFE.
        (0x17, 0x0Y), // D1 lane EQ. Set "Y" to desired value.
        (0x18, 0x03), // D2 lane VOD and TXFFE.
        (0x19, 0x0Y), // D2 lane EQ. Set "Y" to desired value.
        (0x20, 0x02), // Set TMDS_CLK_RATIO
        (0x31, 0x00), // Disable FRL
        (0x11, 0x0F), // Enable all four lanes.
```

```

break;
case 'HDMI21_3G' : // HDMI 2.1 3Gbps FRL
(0x11, 0x00), // Disable all four lanes.
(0x0D, 0x23), // Limited mode, DC-coupled TX, 0dB DCG, Term 100, disable CTLE bypass
(0x12, 0x03), // Clock lane VOD and TXFFE
(0x13, 0x00), // Clock lane EQ.
(0x14, 0x03), // D0 lane VOD and TXFFE.
(0x15, 0x0Y), // D0 lane EQ. Set "Y" to desired value.
(0x16, 0x03), // D1 lane VOD and TXFFE.
(0x17, 0x0Y), // D1 lane EQ. Set "Y" to desired value.
(0x18, 0x03), // D2 lane VOD and TXFFE.
(0x19, 0x0Y), // D2 lane EQ. Set "Y" to desired value.
(0x20, 0x00), // Clear TMDS_CLK_RATIO
(0x31, 0x01), // Set to 3G FRL. Only TXFFE0 supported.
(0x11, 0x0F), // Enable all four lanes.
break;
case 'HDMI21_6G_3lane' : // HDMI 2.1 6Gbps FRL 3 lanes
(0x11, 0x00), // Disable all four lanes.
(0x0D, 0x23), // Limited mode, DC-coupled TX, 0dB DCG, Term 100, disable CTLE bypass
(0x12, 0x03), // Clock lane VOD and TXFFE
(0x13, 0x00), // Clock lane EQ.
(0x14, 0x03), // D0 lane VOD and TXFFE.
(0x15, 0x0Y), // D0 lane EQ. Set "Y" to desired value.
(0x16, 0x03), // D1 lane VOD and TXFFE.
(0x17, 0x0Y), // D1 lane EQ. Set "Y" to desired value.
(0x18, 0x03), // D2 lane VOD and TXFFE.
(0x19, 0x0Y), // D2 lane EQ. Set "Y" to desired value.
(0x20, 0x00), // Clear TMDS_CLK_RATIO
(0x31, 0x02), // Set to 6G FRL and 3 lanes. Only TXFFE0 supported.
(0x11, 0x0F), // Enable all four lanes.
break;
case 'HDMI21_6G_4lane' : // HDMI 2.1 6Gbps FRL 4 lanes
(0x11, 0x00), // Disable all four lanes.
(0x0D, 0x23), // Limited mode, DC-coupled TX, 0dB DCG, Term 100, disable CTLE bypass
(0x12, 0x03), // Clock lane VOD and TXFFE
(0x13, 0x0Y), // Clock lane EQ. Set to "Y" to desired value.
(0x14, 0x03), // D0 lane VOD and TXFFE.
(0x15, 0x0Y), // D0 lane EQ. Set "Y" to desired value.
(0x16, 0x03), // D1 lane VOD and TXFFE.
(0x17, 0x0Y), // D1 lane EQ. Set "Y" to desired value.
(0x18, 0x03), // D2 lane VOD and TXFFE.
(0x19, 0x0Y), // D2 lane EQ. Set "Y" to desired value.
(0x20, 0x00), // Clear TMDS_CLK_RATIO
(0x31, 0x03), // Set to 6G FRL and 4 lanes. Only TXFFE0 supported.
(0x11, 0x0F), // Enable all four lanes.
break;
case 'HDMI21_8G' : //HDMI 2.1 8Gbps FRL
(0x11, 0x00), // Disable all four lanes.
(0x0D, 0x23), // Limited mode, DC-coupled TX, 0dB DCG, Term 100, disable CTLE bypass
(0x12, 0x03), // Clock lane VOD and TXFFE
(0x13, 0x0Y), // Clock lane EQ. Set "Y" to desired value.
(0x14, 0x03), // D0 lane VOD and TXFFE.
(0x15, 0x0Y), // D0 lane EQ. Set "Y" to desired value.
(0x16, 0x03), // D1 lane VOD and TXFFE.
(0x17, 0x0Y), // D1 lane EQ. Set "Y" to desired value.
(0x18, 0x03), // D2 lane VOD and TXFFE.
(0x19, 0x0Y), // D2 lane EQ. Set "Y" to desired value.
(0x20, 0x00), // Clear TMDS_CLK_RATIO
(0x31, 0x04), // Set to 8G FRL and 4 lanes. Only TXFFE0 supported.
(0x11, 0x0F), // Enable all four lanes.
break;
case 'HDMI21_10G' : //HDMI 2.1 10Gbps FRL
(0x11, 0x00), // Disable all four lanes.
(0x0D, 0x23), // Limited mode, DC-coupled TX, 0dB DCG, Term 100, disable CTLE bypass
(0x12, 0x03), // Clock lane VOD and TXFFE
(0x13, 0x0Y), // Clock lane EQ. Set "Y" to desired value.
(0x14, 0x03), // D0 lane VOD and TXFFE.
(0x15, 0x0Y), // D0 lane EQ. Set "Y" to desired value.
(0x16, 0x03), // D1 lane VOD and TXFFE.
(0x17, 0x0Y), // D1 lane EQ. Set "Y" to desired value.
(0x18, 0x03), // D2 lane VOD and TXFFE.
(0x19, 0x0Y), // D2 lane EQ. Set "Y" to desired value.
(0x20, 0x00), // Clear TMDS_CLK_RATIO
(0x31, 0x05), // Set to 10G FRL and 4 lanes. Only TXFFE0 supported.
(0x11, 0x0F), // Enable all four lanes.
break;

```

```

case 'HDMI21_12G' : //HDMI 2.1 12Gbps FRL
(0x11, 0x00), // Disable all four lanes.
(0x0D, 0x23), // Limited mode, DC-coupled TX, 0dB DCG, Term 100, disable CTLE bypass
(0x12, 0x03), // Clock lane VOD and TXFFE
(0x13, 0x0Y), // Clock lane EQ. Set "Y" to desired value.
(0x14, 0x03), // D0 lane VOD and TXFFE.
(0x15, 0x0Y), // D0 lane EQ. Set "Y" to desired value.
(0x16, 0x03), // D1 lane VOD and TXFFE.
(0x17, 0x0Y), // D1 lane EQ. Set "Y" to desired value.
(0x18, 0x03), // D2 lane VOD and TXFFE.
(0x19, 0x0Y), // D2 lane EQ. Set "Y" to desired value.
(0x20, 0x00), // Clear TMDS_CLK_RATIO
(0x31, 0x06), // Set to 12G FRL and 4 lanes. Only TXFFE0 supported.
(0x11, 0x0F), // Enable all four lanes.
break;
}

```

### 7.4.1.2 Sink Example

This example assumes TMDS1204 transmitters are DC-coupled to the HDMI sink. In this example, TMDS1204 will be configured for linear mode with adaptive EQ enabled and TMDS1204 will automatically determine HDMI data rate by snooping DDC traffic between the HDMI source and sink.

```

// (address, data)
// Initial power-on configuration.
(0x0A, 0x00), // Rate snoop and TXFFE snoop enabled.
(0x0B, 0x23), // 3G and 6G slew rate control
(0x0C, 0x00), // HDMI clock tx slew rate control
(0x0D, 0xA3), // Linear mode, DC-coupled TX, 0dB DCG, Term fixed at 100Ω, disable CTLE bypass
(0x0E, 0x97), // HDMI14, 2.0 and 2.1 CTLE selection
(0x12, 0x03), // Clock lane VOD and TXFFE
(0x13, 0x00), // Clock lane EQ.
(0x14, 0x03), // D0 lane VOD and TXFFE.
(0x15, 0x0Y), // D0 lane EQ. Set "Y" to desired value.
(0x16, 0x03), // D1 lane VOD and TXFFE.
(0x17, 0x0Y), // D1 lane EQ. Set "Y" to desired value.
(0x18, 0x03), // D2 lane VOD and TXFFE.
(0x19, 0x0Y), // D2 lane EQ. Set "Y" to desired value.
(0x1E, 0x40), // Enable AEQ
(0x09, 0x00), // Take out of PD state. Should be done after initialization is complete.

```

### 7.4.2 TMDS1204 I<sup>2</sup>C Address Options

For further programmability, the TMDS1204 can be controlled using I<sup>2</sup>C. The SCL/CFG0 and SDA/CFG1 terminals are used for I<sup>2</sup>C clock and I<sup>2</sup>C data respectively.

**Table 7-22. TMDS1204 I<sup>2</sup>C Device Address Description**

ADDR/EQ0 pin	Bit 7 (MSB)	Bit 6	Bit 5	Bit 4	Bit 3	Bit 2	Bit 1	Bit 0 (W/R)	HEX
0	1	0	1	1	1	1	0	0/1	BC/BD
R	1	0	1	1	1	0	1	0/1	BA/BB
F	1	0	1	1	1	0	0	0/1	B8/B9
1	1	0	1	1	0	1	1	0/1	B6/B7

### 7.4.3 I<sup>2</sup>C Target Behavior

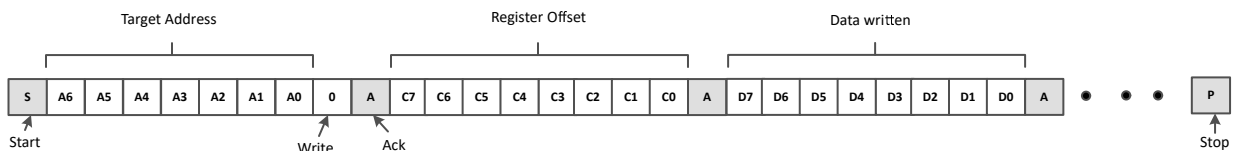

**Figure 7-5. I<sup>2</sup>C Write with Data**

The following procedure should be followed to write data to TMDS1204 I<sup>2</sup>C registers (refer to [Figure 7-5](#)):

1. The controller initiates a write operation by generating a start condition (S), followed by the TMDS1204 7-bit address and a zero-value “W/R” bit to indicate a write cycle.
2. The TMDS1204 acknowledges the address cycle.
3. The controller presents the register offset within TMDS1204 to be written, consisting of one byte of data, MSB-first.
4. The TMDS1204 acknowledges the sub-address cycle.
5. The controller presents the first byte of data to be written to the I<sup>2</sup>C register.
6. The TMDS1204 acknowledges the byte transfer.
7. The controller may continue presenting additional bytes of data to be written, with each byte transfer completing with an acknowledge from the TMDS1204.
8. The controller terminates the write operation by generating a stop condition (P).

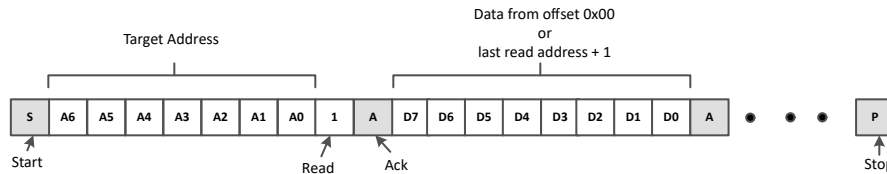

**Figure 7-6. I2C Read Without Repeated Start**

The following procedure should be followed to read the TMDS1204 I<sup>2</sup>C registers without a repeated Start (refer to [Figure 7-6](#)).

1. The controller initiates a read operation by generating a start condition (S), followed by the TMDS1204 7-bit address and a zero-value “W/R” bit to indicate a read cycle.
2. The TMDS1204 acknowledges the 7-bit address cycle.
3. Following the acknowledge the controller continues sending clock.
4. The TMDS1204 transmit the contents of the memory registers MSB-first starting at register 00h or last read register offset+1. If a write to the I<sup>2</sup>C register occurred prior to the read, then the TMDS1204 shall start at the register offset specified in the write.
5. The TMDS1204 waits for either an acknowledge (ACK) or a not-acknowledge (NACK) from the controller after each byte transfer; the I<sup>2</sup>C controller acknowledges reception of each data byte transfer.
6. If an ACK is received, then the TMDS1204 transmits the next byte of data as long as controller provides the clock. If a NAK is received, then the TMDS1204 stops providing data and waits for a stop condition (P).
7. The controller terminates the write operation by generating a stop condition (P).

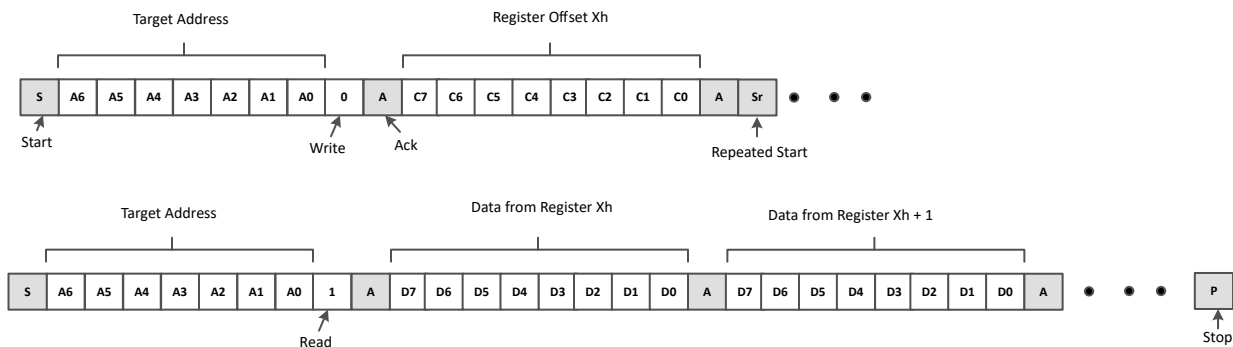
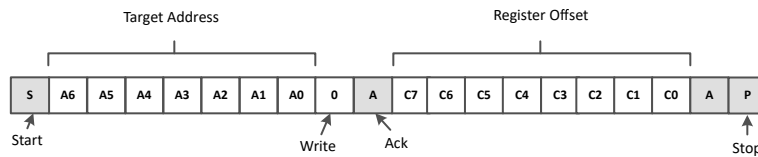

**Figure 7-7. I2C Read with Repeated Start**

The following procedure should be followed to read the TMDS1204 I<sup>2</sup>C registers with a repeated Start (refer to [Figure 7-7](#)).

1. The controller initiates a read operation by generating a start condition (S), followed by the TMDS1204 7-bit address and a zero-value “W/R” bit to indicate a write cycle.
2. The TMDS1204 acknowledges the 7-bit address cycle.

3. The controller presents the register offset within TMDS1204 to be written, consisting of one byte of data, MSB-first.
4. The TMDS1204 acknowledges the register offset cycle.
5. The controller presents a repeated start condition (Sr).
6. The controller initiates a read operation by generating a start condition (S), followed by the TMDS1204 7-bit address and a one-value “W/R” bit to indicate a read cycle.
7. The TMDS1204 acknowledges the 7-bit address cycle.
8. The TMDS1204 transmit the contents of the memory registers MSB-first starting at the register offset.
9. The TMDS1204 shall wait for either an acknowledge (ACK) or a not-acknowledge (NACK) from the controller after each byte transfer; the I<sup>2</sup>C controller acknowledges reception of each data byte transfer.
10. If an ACK is received, then the TMDS1204 transmits the next byte of data as long as controller provides the clock. If a NAK is received, then the TMDS1204 stops providing data and waits for a stop condition (P).
11. The controller terminates the read operation by generating a stop condition (P).



**Figure 7-8. I2C Write Without Data**

The following procedure should be followed for setting a starting sub-address for I<sup>2</sup>C reads (refer to [Figure 7-8](#)).

1. The controller initiates a write operation by generating a start condition (S), followed by the TMDS1204 7-bit address and a zero-value “W/R” bit to indicate a write cycle.
2. The TMDS1204 acknowledges the address cycle.
3. The controller presents the register offset within TMDS1204 to be written, consisting of one byte of data, MSB-first.
4. The TMDS1204 acknowledges the register offset cycle.
5. The controller terminates the write operation by generating a stop condition (P).

**Note**

[Figure 7-6](#) that if no register offset is included for the read procedure after initial power-up, then reads start at register offset 00h and continue byte by byte through the registers until the I<sup>2</sup>C controller terminates the read operation. During a read operation, the TMDS1204 auto-increments the I<sup>2</sup>C internal register address of the last byte transferred independent of whether or not an ACK was received from the I<sup>2</sup>C controller.

**7.5 Register Maps**

**7.5.1 TMDS1204 Registers**

[Table 7-23](#) lists the memory-mapped registers for the TMDS1204 registers. All register offset addresses not listed in [Table 7-23](#) should be considered as reserved locations and the register contents should not be modified.

**Table 7-23. TMDS1204 Registers**

Offset	Acronym	Register Name	Section
8h	REV_ID	Revision ID	<a href="#">Go</a>
9h	PD_RST	Power Down and Reset control	<a href="#">Go</a>
Ah	MISC_CONTROL	Misc Control	<a href="#">Go</a>
Bh	GBL_SLEW_CTRL	Global TX Slew control for data lanes in HDMI1.4 and 2.0	<a href="#">Go</a>
Ch	GBL_SLEW_CTRL2	Global TX Slew control for data and clock	<a href="#">Go</a>
Dh	GBL_CTRL1	Global control	<a href="#">Go</a>
Eh	GBL_CTLLE_CTRL	Global CTLE control	<a href="#">Go</a>
11h	LANE_ENABLE	Lane enables	<a href="#">Go</a>

**Table 7-23. TMDS1204 Registers (continued)**

Offset	Acronym	Register Name	Section
12h	CLK_CONFIG1	CLK lane TX swing and FFE control	<a href="#">Go</a>
13h	CLK_CONFIG2	CLK lane RX EQ control	<a href="#">Go</a>
14h	D0_CONFIG1	D0 lane TX swing and FFE control	<a href="#">Go</a>
15h	D0_CONFIG2	D0 lane RX EQ control	<a href="#">Go</a>
16h	D1_CONFIG1	D1 lane TX swing and FFE control	<a href="#">Go</a>
17h	D1_CONFIG2	D1 lane RX EQ control	<a href="#">Go</a>
18h	D2_CONFIG1	D2 lane TX swing and FFE control	<a href="#">Go</a>
19h	D2_CONFIG2	D2 lane RX EQ control	<a href="#">Go</a>
1Ah	SIGDET_TH_CFG	SIGDET voltage threshold control	<a href="#">Go</a>
1Ch	GBL_STATUS	Global Powerdown and Standby Status	<a href="#">Go</a>
1Dh	AEQ_CONTROL1	Adaptive EQ control1	<a href="#">Go</a>
1Eh	AEQ_CONTROL2	Adaptive EQ control2	<a href="#">Go</a>
20h	SCDC_TMDS_CONFIG	SCDC TMDS Clock Ratio	<a href="#">Go</a>
31h	SCDC_SINK_CONFIG	SCDC SNK FRL FFE and Rate	
35h	SCDC_SRC_TEST	SCDC Test	<a href="#">Go</a>
41h	SCDC_STATUS10	Lanes 0 and 1 FRL Training Status	<a href="#">Go</a>
42h	SCDC_STATUS32	Lanes 2 and 3 FRL Training Status	<a href="#">Go</a>
50h	AEQ_STATUS	Adaptive EQ Status	<a href="#">Go</a>
51h	AEQ_STATUS2	Adaptive EQ Status	<a href="#">Go</a>

Complex bit access types are encoded to fit into small table cells. [Table 7-24](#) shows the codes that are used for access types in this section.

**Table 7-24. TMDS1204 Access Type Codes**

Access Type	Code	Description
<b>Read Type</b>		
R	R	Read
RH	R H	Read Set or cleared by hardware
<b>Write Type</b>		
W	W	Write
W1S	W 1S	Write 1 to set
WtoPH	W toPH	Write Pulse high
<b>Reset or Default Value</b>		
-n		Value after reset or the default value

### 7.5.1.1 REV\_ID Register (Offset = 8h) [Reset = 03h]

REV\_ID is shown in [Table 7-25](#).

Return to the [Summary Table](#).

**Table 7-25. REV\_ID Register Field Descriptions**

Bit	Field	Type	Reset	Description
7-0	REV_ID	RH	3h	Device revision.

### 7.5.1.2 PD\_RST Register (Offset = 9h) [Reset = 01h]

PD\_RST is shown in [Table 7-26](#).

Return to the [Summary Table](#).

**Table 7-26. PD\_RST Register Field Descriptions**

Bit	Field	Type	Reset	Description
7	SOFT_RST	WtoPH	0h	Writing a 1 to this field resets all fields
6	SCDC_SOFT_RST	WtoPH	0h	Writing a 1 to this field resets the fields in the SCDC registers 20h, 31h, 35h, 41h and 42h.
5	RESERVED	R	0h	Reserved
4	RESERVED	R/W	0h	Reserved
3	RESERVED	R	0h	Reserved
2	HPD_PWRDWN_DISABLE	R/W	0h	Mode to ignore HPD pin and always enter active state unless PD_EN is high 0h = Automatically enter power down based on HPD_IN 1h = Always remain in active state or Standby
1	STANDBY_DISABLE	R/W	0h	When high, standby state is disabled and the device will immediately enter active state with all lanes enabled when not in power down. When low, the device will enter standby state when exiting power down and wait for incoming data before entering active state. 0h = Standby state enabled 1h = Standby state disabled
0	PD_EN	R/W	1h	I2C power down. Software should clear this field after it has completed initialization. HPD_OUT will be asserted low when this field is set. 0h = Normal operation 1h = Forced power down by I2C

### 7.5.1.3 MISC\_CONTROL Register (Offset = Ah) [Reset = 08h]

MISC\_CONTROL is shown in [Table 7-27](#).

Return to the [Summary Table](#).

**Table 7-27. MISC\_CONTROL Register Field Descriptions**

Bit	Field	Type	Reset	Description
7	LANE_SWAP	R/W	0h	This field swaps the input and output lanes. 0h = No lanes swapped 1h = Both input and output lanes swapped
6	FANOUT_EN	R/W	0h	Selects whether or not fan-out buffer feature is enabled or not. When enabled, hardware will enable RCLKOUT when operating in HDMI1.4 and HDMI2.0. When operating in HDMI 2.1 mode, OUT_CLK will be enabled for FRL lane 3. 0h = Fan-out buffer feature disabled. 1h = Fan-out buffer feature enabled.
5	RX_TERM_DISABLE	R/W	0h	When set will disable Rx termination. 0h = Enabled when HPD_IN high. 1h = Disable
4	HPD_OUT_SEL	R/W	0h	Selects whether HPD_OUT is push/pull or open-drain. 0h = Push Pull 1h = Open Drain
3	EQ_SNOOP_CTRL	R/W	1h	Control whether Rx EQ is adjusted in response to snooped TXFFE when TXFFE snooping is enabled through registers 41h and 42h. 0h = Rx EQ automatically adjusted for TXFFE 1h = Rx EQ is fixed

**Table 7-27. MISC\_CONTROL Register Field Descriptions (continued)**

Bit	Field	Type	Reset	Description
2	RATE_SNOOP_CTRL	R/W	0h	Control snooping of HDMI rates. When snooping is disabled, correct HDMI rate must be written through I2C to registers 20h and 31h. 0h = Snooping enabled 1h = Snooping disabled
1-0	TXFFE_SNOOP_CTRL	R/W	0h	Control snooping of TXFFE 0h = DDC snooping through registers 35h, 41h and 42h 1h = DDC snooping disabled. TXFFE controlled through I2C writes to 35h, 41h and 42h 2h = DDC snooping disabled. TXFFE controlled through writes to CLK_TXFFE, D0_TXFFE, D1_TXFFE, and D2_TXFFE 3h = DDC snooping disabled. TXFFE controlled through writes to CLK_TXFFE, D0_TXFFE, D1_TXFFE, and D2_TXFFE

**7.5.1.4 GBL\_SLEW\_CTRL Register (Offset = Bh) [Reset = 34h]**

GBL\_SLEW\_CTRL is shown in [Table 7-28](#).

Return to the [Summary Table](#).

**Table 7-28. GBL\_SLEW\_CTRL Register Field Descriptions**

Bit	Field	Type	Reset	Description
7	RESERVED	R	0h	Reserved
6-4	SLEW_3G	R/W	3h	Field controls slew rate for HDMI 1.4 data lane and HDMI 2.1 3Gbps FRL data lanes. 0h = slowest edge rate 7h = fastest edge rate
3	RESERVED	R	0h	Reserved
2-0	SLEW_6G	R/W	4h	Field controls slew rate for HDMI 2.0 data lanes and HDMI 2.1 6Gbps FRL data lanes. 0h = slowest edge rate 7h = fastest edge rate

**7.5.1.5 GBL\_SLEW\_CTRL2 Register (Offset = Ch) [Reset = 71h]**

GBL\_SLEW\_CTRL2 is shown in [Table 7-29](#).

Return to the [Summary Table](#).

**Table 7-29. GBL\_SLEW\_CTRL2 Register Field Descriptions**

Bit	Field	Type	Reset	Description
7	RESERVED	R	0h	Reserved
6-4	SLEW_8G10G12G	R/W	7h	Field controls slew rate for data lanes for 8Gbps, 10Gbps and 12Gbps FRL datarates 0h = slowest edge rate 7h = fastest edge rate
3	RESERVED	R	0h	Reserved
2-0	SLEW_CLK	R/W	1h	Field control slew rate of clock lane in HDMI 1.4b and HDMI 2.0 modes. 0h = slowest edge rate 7h = fastest edge rate

**7.5.1.6 GBL\_CTRL1 Register (Offset = Dh) [Reset = 22h]**

GBL\_CTRL1 is shown in [Table 7-30](#).

Return to the [Summary Table](#).

**Table 7-30. GBL\_CTRL1 Register Field Descriptions**

Bit	Field	Type	Reset	Description
7	GLOBAL_LINR_EN	R/W	0h	Global control for selecting between linear redriver or limited redriver. 0h = Limited 1h = Linear
6	TX_AC_EN	R/W	0h	Controls selection of ac-coupled or dc-coupled TX termination. When AC-coupled is enabled, 50 Ω termination on both P and N to VCC will be enabled. 0h = dc-coupled 1h = ac-coupled
5-4	GLOBAL_DCG	R/W	2h	CTLE DCGain for all lane. 0h = -3dB 1h = -3dB 2h = 0dB 3h = +1dB
3	TXTERM_AUTO_HDMI14	R/W	0h	Selects between no termination and 300 Ωs when TERM = 2h and operating in HDMI1.4. 0h = No termination for clock less than or equal to 165MHz and 300 Ω for clock greater than 225MHz 1h = 300 Ω
2	CTLEBYP_EN	R/W	0h	Selects whether or not CTLE bypass is enabled or not when GLOBAL_DCG is set to 2h and EQ set to 0h. 0h = CTLE bypass disabled 1h = CTLE bypass enabled
1-0	TERM	R/W	2h	TX termination control 0h = No termination 1h = 300 Ω 2h = Automatic based HDMI mode 3h = 100 Ω

### 7.5.1.7 GBL\_CTLE\_CTRL Register (Offset = Eh) [Reset = 3Fh]

GBL\_CTLE\_CTRL is shown in [Table 7-31](#).

Return to the [Summary Table](#).

**Table 7-31. GBL\_CTLE\_CTRL Register Field Descriptions**

Bit	Field	Type	Reset	Description
7-6	GLOBAL_CTLEBW	R/W	0h	CTLE bandwidth control. 0 is lowest and 3h is highest.
5-4	HDMI14_CTLE_SEL	R/W	3h	Selects the CTLE used when datarate is HDMI 1.4. Value programmed into this field will apply to data lanes only. Clock lane will always use 3Gbps CTLE. 0h = 3Gbps CTLE 1h = 6Gbps CTLE 2h = Auto select based on snoop datarate 3h = 12Gbps CTLE
3-2	HDMI20_CTLE_SEL	R/W	3h	Selects the CTLE used when datarate is HDMI 2.0. Value programmed into this field will apply to data lanes only. Clock lane will always use 3Gbps CTLE. 0h = 3Gbps CTLE 1h = 6Gbps CTLE 2h = Auto select based on snoop datarate 3h = 12Gbps CTLE
1-0	HDMI21_CTLE_SEL	R/W	3h	Selects the CTLE used when datarate is HDMI 2.1. Value programmed into this field will apply to all four lanes. 0h = 3Gbps CTLE 1h = 6Gbps CTLE 2h = Auto select based on snoop datarate 3h = 12Gbps CTLE

### 7.5.1.8 LANE\_ENABLE Register (Offset = 11h) [Reset = 5Fh]

LANE\_ENABLE is shown in [Table 7-32](#).

Return to the [Summary Table](#).

**Table 7-32. LANE\_ENABLE Register Field Descriptions**

Bit	Field	Type	Reset	Description
7-6	HDMI20_VOD	R/W	1h	VOD control for limited redriver in HDMI 2.0 0h = Use values in CLK_VOD, D0_VOD, D1_VOD and D2_VOD 1h = Default (1000mV) 2h = Default - 5% 3h = Default + 5%
5-4	HDMI14_VOD	R/W	1h	VOD control for limited redriver in HDMI 1.4 0h = Use values in CLK_VOD, D0_VOD, D1_VOD and D2_VOD 1h = Default (1000mV) 2h = Default - 5% 3h = Default - 10%
3	CLK_LANE_EN	R/W	1h	Enable for CLK lane 0h = Disabled 1h = Enabled
2	D0_LANE_EN	R/W	1h	Enable for D0 lane 0h = Disabled 1h = Enabled
1	D1_LANE_EN	R/W	1h	Enable for D0 lane 0h = Disabled 1h = Enabled
0	D2_LANE_EN	R/W	1h	Enable for D0 lane 0h = Disabled 1h = Enabled

### 7.5.1.9 CLK\_CONFIG1 Register (Offset = 12h) [Reset = 03h]

CLK\_CONFIG1 is shown in [Table 7-33](#).

Return to the [Summary Table](#).

**Table 7-33. CLK\_CONFIG1 Register Field Descriptions**

Bit	Field	Type	Reset	Description
7	RESERVED	R	0h	Reserved
6-4	CLK_TXFFE	R/W	0h	TXFFE control for CLK lane. This field is only honored in HDMI 2.1. 0h = 0.0dB 1h = 3.5dB 2h = 6.0dB 3h = Reserved 4h = -1.5dB 5h = -2.5dB 6h = -3.5dB 7h = -4.8dB
3	RESERVED	R	0h	Reserved
2-0	CLK_VOD	R/W	3h	Differential Swing control for CLK lane. 0h = Limited -15% Linear 800mV 1h = Limited -10% Linear 900mV 2h = Limited - 5% Linear 1000mV 3h = Limited 800mV Linear 1200mV 4h = Limited +5% Linear Reserved 5h = Limited +10% Linear Reserved 6h = Limited +15% Linear Reserved 7h = Limited +20% Linear Reserved

### 7.5.1.10 CLK\_CONFIG2 Register (Offset = 13h) [Reset = 00h]

CLK\_CONFIG2 is shown in [Table 7-34](#).

Return to the [Summary Table](#).

**Table 7-34. CLK\_CONFIG2 Register Field Descriptions**

Bit	Field	Type	Reset	Description
7-4	RESERVED	R	0h	Reserved
3-0	CLK_EQ	R/W	0h	EQ control for CLK lane. This field is only honored in HDMI 2.1. 0h = Min EQ Fh = Max EQ

### 7.5.1.11 D0\_CONFIG1 Register (Offset = 14h) [Reset = 03h]

D0\_CONFIG1 is shown in [Table 7-35](#).

Return to the [Summary Table](#).

**Table 7-35. D0\_CONFIG1 Register Field Descriptions**

Bit	Field	Type	Reset	Description
7	RESERVED	R	0h	Reserved
6-4	D0_TXFFE	R/W	0h	TXFFE control for D0 lane. 0h = 0.0dB 1h = 3.5dB 2h = 6.0dB 3h = Reserved 4h = -1.5dB 5h = -2.5dB 6h = -3.5dB 7h = -4.8dB
3	RESERVED	R	0h	Reserved
2-0	D0_VOD	R/W	3h	Differential Swing control for D0 lane. 0h = Limited -15% Linear 800mV 1h = Limited -10% Linear 900mV 2h = Limited -5% Linear 1000mV 3h = Limited 1000mV Linear 1200mV 4h = Limited +5% Linear Reserved 5h = Limited +10% Linear Reserved 6h = Limited +15% Linear Reserved 7h = Limited +20% Linear Reserved

### 7.5.1.12 D0\_CONFIG2 Register (Offset = 15h) [Reset = 00h]

D0\_CONFIG2 is shown in [Table 7-36](#).

Return to the [Summary Table](#).

**Table 7-36. D0\_CONFIG2 Register Field Descriptions**

Bit	Field	Type	Reset	Description
7-4	RESERVED	R	0h	Reserved
3-0	D0_EQ	R/W	0h	EQ control for D0 lane. 0h = Min EQ Fh = Max EQ

### 7.5.1.13 D1\_CONFIG1 Register (Offset = 16h) [Reset = 03h]

D1\_CONFIG1 is shown in [Table 7-37](#).

Return to the [Summary Table](#).

**Table 7-37. D1\_CONFIG1 Register Field Descriptions**

Bit	Field	Type	Reset	Description
7	RESERVED	R	0h	Reserved
6-4	D1_TXFFE	R/W	0h	TXFFE control for D1 lane. 0h = 0.0dB 1h = 3.5dB 2h = 6.0dB 3h = Reserved 4h = -1.5dB 5h = -2.5dB 6h = -3.5dB 7h = -4.8dB
3	RESERVED	R	0h	Reserved
2-0	D1_VOD	R/W	3h	Differential Swing control for D1 lane. 0h = Limited -15% Linear 800mV 1h = Limited -10% Linear 900mV 2h = Limited -5% Linear 1000mV 3h = Limited 1000mV Linear 1200mV 4h = Limited +5% Linear Reserved 5h = Limited +10% Linear Reserved 6h = Limited +15% Linear Reserved 7h = Limited +20% Linear Reserved

**7.5.1.14 D1\_CONFIG2 Register (Offset = 17h) [Reset = 00h]**

D1\_CONFIG2 is shown in [Table 7-38](#).

Return to the [Summary Table](#).

**Table 7-38. D1\_CONFIG2 Register Field Descriptions**

Bit	Field	Type	Reset	Description
7-4	RESERVED	R	0h	Reserved
3-0	D1_EQ	R/W	0h	EQ control for D1 lane 0h = Min EQ Fh = Max EQ

**7.5.1.15 D2\_CONFIG1 Register (Offset = 18h) [Reset = 03h]**

D2\_CONFIG1 is shown in [Table 7-39](#).

Return to the [Summary Table](#).

**Table 7-39. D2\_CONFIG1 Register Field Descriptions**

Bit	Field	Type	Reset	Description
7	RESERVED	R	0h	Reserved
6-4	D2_TXFFE	R/W	0h	TXFFE control for D2 lane 0h = 0.0dB 1h = 3.5dB 2h = 6.0dB 3h = Reserved 4h = -1.5dB 5h = -2.5dB 6h = -3.5dB 7h = -4.8dB
3	RESERVED	R	0h	Reserved

**Table 7-39. D2\_CONFIG1 Register Field Descriptions (continued)**

Bit	Field	Type	Reset	Description
2-0	D2_VOD	R/W	3h	Differential Swing control for D2 lane. 0h = Limited -15% Linear 800mV 1h = Limited -10% Linear 900mV 2h = Limited -5% Linear 1000mV 3h = Limited 1000mV Linear 1200mV 4h = Limited +5% Linear Reserved 5h = Limited +10% Linear Reserved 6h = Limited +15% Linear Reserved 7h = Limited +20% Linear Reserved

#### 7.5.1.16 D2\_CONFIG2 Register (Offset = 19h) [Reset = 00h]

D2\_CONFIG2 is shown in [Table 7-40](#).

Return to the [Summary Table](#).

**Table 7-40. D2\_CONFIG2 Register Field Descriptions**

Bit	Field	Type	Reset	Description
7-4	RESERVED	R	0h	Reserved
3-0	D2_EQ	R/W	0h	EQ control for D2 lane. 0h = Min EQ Fh = Max EQ

#### 7.5.1.17 SIGDET\_TH\_CFG Register (Offset = 1Ah) [Reset = 44h]

SIGDET\_TH\_CFG is shown in [Table 7-41](#).

Return to the [Summary Table](#).

**Table 7-41. SIGDET\_TH\_CFG Register Field Descriptions**

Bit	Field	Type	Reset	Description
7	RESERVED	R	0h	Reserved
6-4	CFG_SIGDET_HYST	R/W	4h	Controls the SIGDET hysteresis. Value programmed into this field plus value programmed into CFG_SIGDET_VTH field defines the SIGDET assert threshold. 0h = 0mV 1h = 12mV 2h = 25mV 3h = 37mV 4h = 55mV 5h = 63mV 6h = 75mV 7h = 90mV
3	RESERVED	R	0h	Reserved
2-0	CFG_SIGDET_VTH	R/W	4h	Controls the SIGDET de-assert voltage threshold. 0h = 58mV 1h = 60mV 2h = 72mV 3h = 84mV 4h = 95mV 5h = 108mV 6h = 120mV 7h = 135mV

#### 7.5.1.18 GBL\_STATUS Register (Offset = 1Ch) [Reset = 00h]

GBL\_STATUS is shown in [Table 7-42](#).

Return to the [Summary Table](#).

**Table 7-42. GBL\_STATUS Register Field Descriptions**

Bit	Field	Type	Reset	Description
7	PD_STATUS	RH	0h	Power Down status
6	STANDBY_STATUS	RH	0h	Standby Status
5-0	RESERVED	R	0h	Reserved

**7.5.1.19 AEQ\_CONTROL1 Register (Offset = 1Dh) [Reset = F3h]**

AEQ\_CONTROL1 is shown in [Table 7-43](#).

Return to the [Summary Table](#).

**Table 7-43. AEQ\_CONTROL1 Register Field Descriptions**

Bit	Field	Type	Reset	Description
7-4	FULLAEQ_UPPER_EQ	R/W	Fh	Maximum EQ value to check for full AEQ mode
3-2	AEQ_PATTERN_CTRL	R/W	0h	Control how link training pattern snooping for EQ adaptation 0h = Require a read of pattern register 41h/42h after a rate change. Allow eq adaptation for patterns 0, 5, 6, 7, and 8. 1h = Require a read of pattern register 41h/42h after a rate change. Allow eq adaptation for patterns 5, 6, 7, and 8. 2h = Allow eq adaptation for patterns 0, 5, 6, 7, and 8. No need for read after rate change 3h = Allow eq adaptation for patterns 5, 6, 7, and 8. No need for read after rate change.
1	AEQ_START_CTRL	R/W	1h	Control whether starts based on signal detect or both signal detect and FLT_UPDATE cleared 0h = Only require signal detect 1h = Require signal detect and clearing of FLT_UPDATE
0	AEQ_TX_DELAY_EN	R/W	1h	Control whether TX remains disabled during EQ adaptation 0h = TX active during adaptation 1h = TX disabled during adaptation

**7.5.1.20 AEQ\_CONTROL2 Register (Offset = 1Eh) [Reset = 00h]**

AEQ\_CONTROL2 is shown in [Table 7-44](#).

Return to the [Summary Table](#).

**Table 7-44. AEQ\_CONTROL2 Register Field Descriptions**

Bit	Field	Type	Reset	Description
7	AEQ_MODE	R/W	0h	Selects between two Adaption modes 0h = AEQ with hits counted at mideye for every EQ. 1h = AEQ with hits counted at mideye only for EQ equal 0.
6	AEQ_EN	R/W	0h	Controls whether or not adaptive EQ is enabled. 0h = AEQ disabled 1h = AEQ enabled
5-4	RESERVED	R/W	0h	Reserved
3	OVER_EQ_SIGN	R/W	0h	Selects the sign for OVER_EQ_CTRL field. 0h = positive 1h = negative

**Table 7-44. AEQ\_CONTROL2 Register Field Descriptions (continued)**

Bit	Field	Type	Reset	Description
2-0	OVER_EQ_CTRL	R/W	0h	This field will increase or decrease the AEQ by value programmed into this field. For example, full AEQ value is 6 and this field is programmed to 2 and OVER_EQ_SIGN = 0, then EQ value used will be 8. This field is only used in Full AEQ mode. 0h = 0 or -8 1h = 1 or -7 2h = 2 or -6 3h = 3 or -5 4h = 4 or -4 5h = 5 or -3 6h = 6 or -2 7h = 7 or -1

#### 7.5.1.21 SCDC\_TMDS\_CONFIG Register (Offset = 20h) [Reset = 00h]

SCDC\_TMDS\_CONFIG is shown in [Table 7-45](#).

Return to the [Summary Table](#).

**Table 7-45. SCDC\_TMDS\_CONFIG Register Field Descriptions**

Bit	Field	Type	Reset	Description
7-2	RESERVED	R	0h	Reserved
1	TMDS_CLK_RATIO	RH/W	0h	TMDS Bit Period to TMDS Clock Period Ratio. Reads last value snooped through DDC read/write or I2C write. 0h = 1/10 (HDMI 1.4b) 1h = 1/40 (HDMI 2.0)
0	RESERVED	R	0h	Reserved

#### 7.5.1.22 SCDC\_SINK\_CONFIG Register (Offset = 31h) [Reset = 00h]

SCDC\_SINK\_CONFIG is shown in [Table 7-46](#).

Return to the [Summary Table](#).

**Table 7-46. SCDC\_SINK\_CONFIG Register Field Descriptions**

Bit	Field	Type	Reset	Description
7-4	FFE_LEVELS	RH/W	0h	Indicates the maximum TXFFE level supported for the current FRL rate. Read last value snooped through DDC read/write or I2C write. 0h = Only TXFFE0 supported 1h = TXFFE0-1 supported 2h = TXFFE0-2 supported 3h = TXFFE0-3 supported
3-0	FRL_RATE	RH/W	0h	Selects FRL rate and lane count. Read last value snooped through DDC read/write or I2C write. 0h = Disable FRL 1h = 3Gbps on 3 lanes 2h = 6Gbps on 3 lanes 3h = 6Gbps on 4 lanes 4h = 8Gbps on 4 lanes 5h = 10Gbps on 4 lanes 6h = 12Gbps on 4 lanes

#### 7.5.1.23 SCDC\_SRC\_TEST Register (Offset = 35h) [Reset = 00h]

SCDC\_SRC\_TEST is shown in [Table 7-47](#).

Return to the [Summary Table](#).

**Table 7-47. SCDC\_SRC\_TEST Register Field Descriptions**

Bit	Field	Type	Reset	Description
7-6	RESERVED	R	0h	Reserved
5	FLT_NO_TIMEOUT	RH/W	0h	Set by sink test equipment to have source not time out during FRL link training 0h = Normal operation 1h = Source does not timeout
4	RESERVED	R	0h	Reserved
3	TX_NO_FFE	RH/W	0h	Test mode to disable FFE. Read last value snooped through DDC read/write or I2C write. 0h = Normal TXFFE 1h = TX sent with no FFE
2	TX_DEEMPH_ONLY	RH/W	0h	Test mode to enable de-emphasis only. Read last value snooped through DDC read/write or I2C write. 0h = Normal TXFFE 1h = TX sent de-emphasis only
1	TX_PRESHOOT_ONLY	RH/W	0h	Test mode to enable pre-shoot only. Read last value snooped through DDC read/write or I2C write. 0h = Normal TXFFE 1h = TX sent with pre-shoot only
0	RESERVED	R	0h	Reserved

**7.5.1.24 SCDC\_STATUS10 Register (Offset = 41h) [Reset = 00h]**

SCDC\_STATUS10 is shown in [Table 7-48](#).

Return to the [Summary Table](#).

**Table 7-48. SCDC\_STATUS10 Register Field Descriptions**

Bit	Field	Type	Reset	Description
7-4	LN1_LTP_REQ	RH/W	0h	Link training pattern request for lane 1. Reads last value read through DDC or written through I2C. A DDC read/I2C write of Eh advances the current FFE level for this lane saturating at the value of FFE_LEVELS. A DDC read/I2C write of Fh clears for FFE level for all lanes to TXFFE0.
3-0	LN0_LTP_REQ	RH/W	0h	Link training pattern request for lane 0. Reads last value read through DDC or written through I2C. A DDC read/I2C write of Eh advances the current FFE level for this lane saturating at the value of FFE_LEVELS. A DDC read/I2C write of Fh clears for FFE level for all lanes to TXFFE0.

**7.5.1.25 SCDC\_STATUS32 Register (Offset = 42h) [Reset = 00h]**

SCDC\_STATUS32 is shown in [Table 7-49](#).

Return to the [Summary Table](#).

**Table 7-49. SCDC\_STATUS32 Register Field Descriptions**

Bit	Field	Type	Reset	Description
7-4	LN3_LTP_REQ	RH/W	0h	Link training pattern request for lane 3. Reads last value read through DDC or written through I2C. A DDC read/I2C write of Eh advances the current FFE level for this lane saturating at the value of FFE_LEVELS. A DDC read/I2C write of Fh clears for FFE level for all lanes to TXFFE0.

**Table 7-49. SCDC\_STATUS32 Register Field Descriptions (continued)**

Bit	Field	Type	Reset	Description
3-0	LN2_LTP_REQ	RH/W	0h	Link training pattern request for lane 2. Reads last value read through DDC or written through I2C. A DDC read/I2C write of Eh advances the current FFE level for this lane saturating at the value of FFE_LEVELS. A DDC read/I2C write of Fh clears for FFE level for all lanes to TXFFE0.

#### 7.5.1.26 AEQ\_STATUS Register (Offset = 50h) [Reset = 80h]

AEQ\_STATUS is shown in [Table 7-50](#).

Return to the [Summary Table](#).

**Table 7-50. AEQ\_STATUS Register Field Descriptions**

Bit	Field	Type	Reset	Description
7	AEQDONE_STAT	RH	1h	This field is low while AEQ is active and high when it is done. It is valid when FRL training and AEQ_EN = 1 or when FORCE_AEQ_EN = 1 and HW has reset FORCE_AEQ back to 0. 0h = AEQ is running 1h = AEQ is done
6	AEQ_HC_OVERFLOW	RH	0h	13-bit AEQ hit counter overflow status
5	RESERVED	R	0h	Reserved
4	RXD1_DONE_STAT	RH	0h	This flag is set after DAC wait timer expires.
3-0	RXD1_AEQ_STAT	RH	0h	Optimal EQ determined by FSM after the completion of Full AEQ. This field will include the value programmed into OVER_EQ_CTRL field.

#### 7.5.1.27 AEQ\_STATUS2 Register (Offset = 51h) [Reset = 00h]

AEQ\_STATUS2 is shown in [Table 7-51](#).

Return to the [Summary Table](#).

**Table 7-51. AEQ\_STATUS2 Register Field Descriptions**

Bit	Field	Type	Reset	Description
7	RESERVED	R	0h	Reserved
6-4	VOD_RANGE_STAT	RH	0h	VOD range selected by the last AEQ run
3-0	AEQ_EYE_STAT	RH	0h	EYE status from the last AEQ run. Relative to the max limit of 15.

## 8 Application and Implementation

### Note

Information in the following applications sections is not part of the TI component specification, and TI does not warrant its accuracy or completeness. TI's customers are responsible for determining suitability of components for their purposes, as well as validating and testing their design implementation to confirm system functionality.

TMDS1204 is designed to accept AC or DC-coupled HDMI input signals. The device provides signal conditioning and level shifting functions to drive a compliant HDMI source connector. The device can be used in an HDMI sink application such as monitor or TV. The TMDS1204 can also be used as a DP/HDMI redriver in an embedded application. In many major PC or gaming systems APU/GPU will provide AC-coupled HDMI signals. TMDS1204 is suitable for such platforms.

### 8.1 Application Information

The TMDS1204 features are optimized for sink applications such as TV or monitors, but TMDS1204 can also support source applications such as Blu-ray™ DVD player, gaming system, desktops, and notebooks. The following sections provide design considerations for the various types of applications.

### 8.2 Typical Source-Side Application

Figure 8-1 shows a schematic representation of what is considered a standard source implementation.

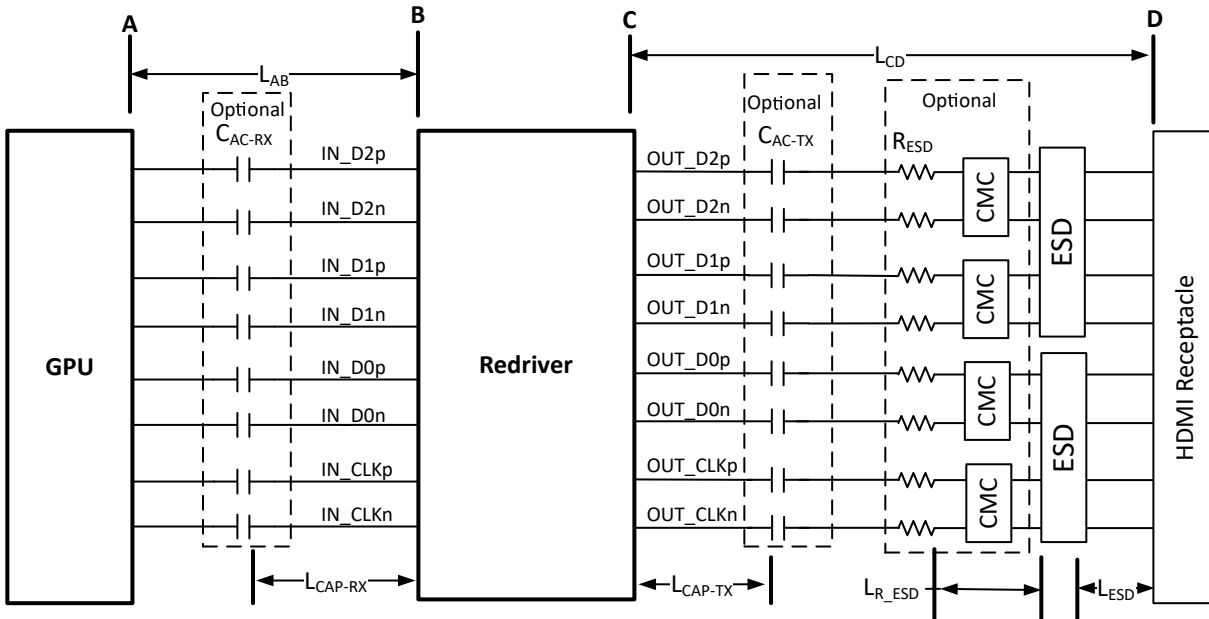

Figure 8-1. TMDS1204 in Source Side Application

## 8.2.1 Design Requirements

The TMDS1204 can be designed into many different applications. In all the applications there are certain requirements for the system to work properly. The EN pin must have a 0.1- $\mu$ F capacitor to ground. The processor can drive the EN pin, but the EN pin needs to change states (low to high) after the voltage rails have stabilized. Using I<sup>2</sup>C is the best way to configure the device, but pin strapping is also provided as I<sup>2</sup>C and is not available in all cases. As sources may have many different naming conventions, it is necessary to confirm that the link between the source and the TMDS1204 are correctly mapped. A Swap function is provided for the input pins in case signaling is reversed between the source and receptacle. [Table 8-1](#) lists information on expected values to perform properly.

For this design example, the TMDS1204 is assumed to be configured for pin-strap mode. If I2C mode is desired, the MODE pin should be set to "F" and software must configure TMDS1204. For how to configure TMDS1204, refer to [Section 7.4.1](#).

**Table 8-1. Design Parameters**

Design Parameter	Value
V <sub>CC</sub>	3.3V
V <sub>IO</sub> (1.2V, 1.8V, or 3.3V LVCMOS levels)	1.8V
Maximum HDMI 2.1 FRL Datarate (3, 6, 8, 10, or 12Gbps)	12Gbps
Pin-strap or I2C mode (if I2C, then MODE = "F").	Pin-strap
Pin Strap Mode.(MODE = "0", "R" or "1").	Mode = "0" (Fixed EQ)
DDC Snoop Feature. (Y/N). Required when in pin strap. Optional in I2C mode.	Yes
SWAP function (Y / N). In pin strap mode controlled by SDA/CFG1 pin.	Yes. SDA/CFG1 pin = H.
HPD_IN to HPD_OUT Level Shifter Support (Y / N)	Yes, HPD_OUT is used. If no, then HPD_OUT can be left floating.
Pre-Channel Length ( <a href="#">Table 8-2</a> provides the length restrictions)	Length = 8 inches ( $\approx$ 7.2dB at 6GHz insertion loss)
Post-Channel Length ( <a href="#">Table 8-2</a> provides the length restrictions)	Length = 2 inches ( $\approx$ 1.8dB at 6GHz insertion loss)
Limited or linear redriver mode?	Limited redriver (LINEAR_EN pin = "0").
TX is DC or AC-coupled to HDMI receptacle?	DC-coupled. AC_EN pin = Low.
GPU Launch Voltage (500mV to 1200mV) if using limited redriver mode. If using linear redriver mode, then refer to the GPU requirements listed in <a href="#">Table 7-4</a> .	500mV
GPU HDMI 2.1 pre-shoot and de-emphasis levels used if using redriver in limited mode	If MODE = "0" or "R", GPU's TX FFE pre-shoot and de-emphasis levels shall be set to 0dB for all four TXFFE levels If MODE = "1", then GPU TXFFE pre-shoot and de-emphasis levels shall meet the requirements listed in <a href="#">Table 7-4</a> .
RX EQ (16 possible values. Value chosen based on pre-channel length).	EQ1 pin: "R" ADDR/EQ0 pin: "R" (7.5dB)
TX Pre-emphasis. In pre-strap mode controlled by TXPRE pin.	Default 0dB of pre-emphasis. Float TXPRE pin.
TX Swing. In pre-strap mode controlled by TXSWG pin.	Default TX swing level. Float TXSWG pin.

**Table 8-2. Source Layout and Component Placement Constraints**

Symbol	Parameter	Condition	Min	Typ	Max	Units
R <sub>ESD</sub>	External series resistor between ESD component and TMDS1204		0		2.5	Ω
L <sub>AB</sub> <sup>(1) (2)</sup>	PCB trace length from GPU to TMDS1204	At 12Gbps	1		10	inches
L <sub>INTRA-AB</sub>	Intra-pair skew from GPU to TMDS1204				5	mil
L <sub>CD</sub> <sup>(1)</sup>	PCB trace length from TMDS1204 to receptacle	At 12Gbps	0.75		2	inches
L <sub>INTRA-CD</sub>	Intra-pair skew from TMDS1204 to receptacle				5	mil
L <sub>CAP-RX</sub>	PCB trace length from TMDS1204 to optional external C <sub>AC-RX</sub> capacitor		0.3			inches
L <sub>CAP-TX</sub>	PCB trace length from TMDS1204 to optional external C <sub>AC-TX</sub> capacitor		0.3			inches
L <sub>ESD</sub>	PCB trace length from ESD component to receptacle				0.5	inches
L <sub>R_ESD</sub>	PCB trace length from R <sub>ESD</sub> to ESD component				0.25	inches
L <sub>INTER-PAIR</sub> <sup>(3)</sup>	Inter-pair skew between all four channels (D0, D1, D2, and CLK)				1	inches
IL <sub>PCB</sub>	PCB trace insertion loss		0.1		0.17	dB / inch /GHz
Z <sub>PCB_AB</sub>	Differential impedance of L <sub>AB</sub>		75		110	Ω
Z <sub>PCB_CD</sub>	Differential impedance of L <sub>CD</sub>		90		110	Ω
VIA <sub>AB</sub>	Number of vias between GPU and TMDS1204				2	VIA
VIA <sub>CD</sub>	Number of vias between HDMI connector and TMDS1204				1	VIA
XTALK	Differential crosstalk between adjacent differential pairs on PCB.	≤ 3GHz			-24	dB

- (1) Maximum distance assumes PCB trace insertion loss meets IL<sub>PCB</sub> requirement. If PCB trace insertion loss exceeds the maximum limit, then distance needs to be reduced.
- (2) Minimum distance assumes PCB trace insertion loss meets IL<sub>PCB</sub> requirement. If PCB trace insertion loss is less than the minimum limit, then distance needs to be increased.
- (3) Calculation of channel length is the sum of L<sub>AB</sub> and L<sub>CD</sub>.

### 8.2.2 Detailed Design Procedure

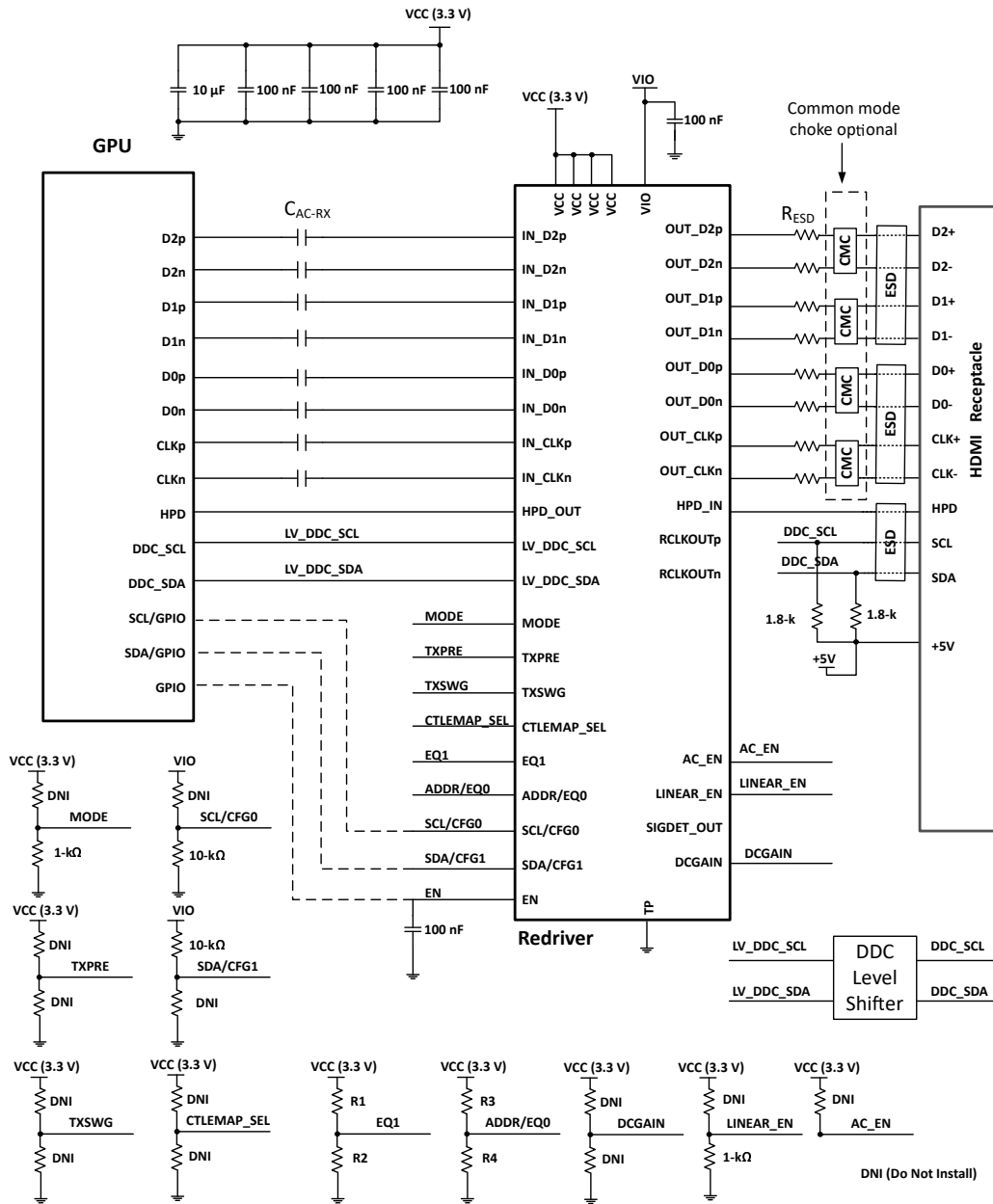

Figure 8-2. TMDS1204 in Source Application Schematics

### 8.2.2.1 Pre-Channel ( $L_{AB}$ )

The TMDS1204 can support up to 12dB at 6GHz of insertion loss. The loss profile between the GPU and the TMDS1204 input (referred to the pre-channel as shown in [Figure 8-1](#)) should be less than the TMDS1204 maximum receiver equalization. [Figure 8-3](#) shows the loss profile of FR4 trace at different lengths. The TMDS1204 EQ0 and EQ1 pins should be configured to match the pre-channel insertion loss. [Table 7-6](#) lists the EQ0 and EQ1 configuration options.

The GPU transmitter differential output voltage swing must be large enough so that the TMDS1204's  $V_{ID(DC)}$  and  $V_{ID(EYE)}$  requirements are met. The  $V_{ID(EYE)}$  is the eye height after the contribution of ISI jitter only. Because a redriver can only compensate for ISI jitter, all non-ISI sources of jitter (random, sinusoidal, and so forth) will be passed through TMDS1204. If the system designer requires the worse case channel length of 10 inches, then the GPU transmitter differential voltage swing without de-emphasis should be at least 1000mVpp to meet the  $V_{ID(DC)}$  and  $V_{ID(EYE)}$  requirements of the TMDS1204. A GPU transmitter, which incorporates de-emphasis, can meet the requirement with less than 1000mVpp.

### 8.2.2.2 Post-Channel ( $L_{CD}$ )

[Figure 8-1](#) shows the post-channel, which should be 2 inches or less. If ESD devices are used, then it may be necessary to overcome the insertion loss of the ESD device by increasing the TMDS1204 transmitter voltage swing. [Table 7-17](#) lists how this is done by configuring the TXSWG pin to the appropriate value.

If post-channel is greater than 2 inches, then transmitter pre-emphasis may need to be employed. [Table 7-15](#) lists how this is done by configuring the TMDS1204 TXPRE pin to the appropriate setting. Adjusting the TMDS1204 transmitter voltage swing may also be necessary.

### 8.2.2.3 Common Mode Choke

It may be necessary to incorporate a common mode choke (CMC) to reduce EMI. The purpose of a CMC is to have a minimal impact to the differential signal while attenuating common mode noise thereby reducing radiated emissions. The CMC should be placed between the TMDS1204 and the ESD device.

**Table 8-3. Recommended Common Mode Chokes**

Manufacturer	Part Number
Murata	DLM0QSB120HY2
Murata	DLM0NSB120HY2
Murata	NFG0QHB542HS2

### 8.2.2.4 ESD Protection

It may be necessary to incorporate an ESD component to protect the TMDS1204 from electrostatic discharge (ESD). It is recommended that the ESD protection component has a breakdown voltage of  $\geq 4.5V$  and a clamp voltage of  $\leq 4.3V$ . A clamp voltage greater than 4.3V will require a  $R_{ESD}$  on each high-speed differential pin. The ESD component should be placed near the HDMI connector.

**Table 8-4. Recommended ESD Protection Component**

Manufacturer	Part Number
NXP	PUSB3FR4

### 8.2.3 Application Curves

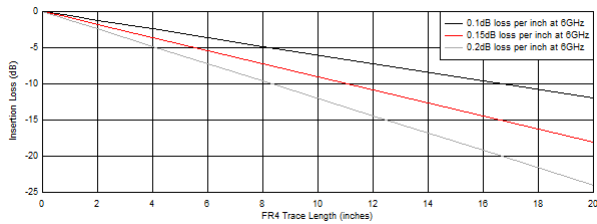

**Figure 8-3. FR4 Trace Insertion Loss at 6GHz**

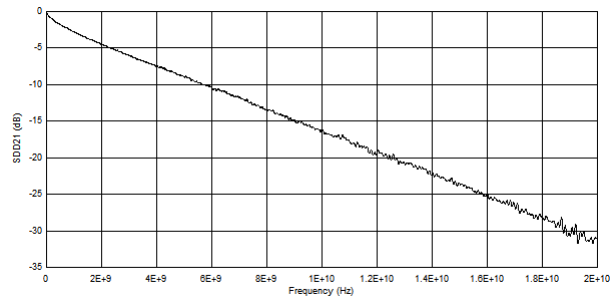

**Figure 8-4. Pre-Channel Insertion Loss at TTP2**

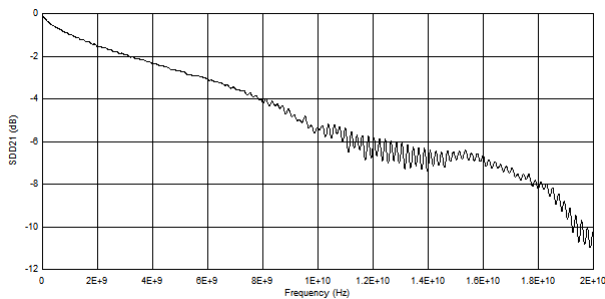

**Figure 8-5. Post-Channel Insertion Loss at TTP4**

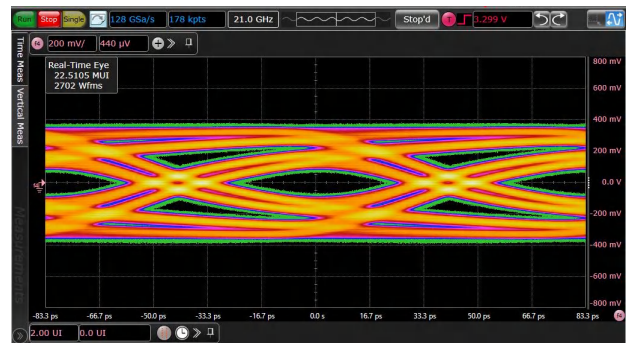

**Figure 8-6. 12Gbps Input Eye at TTP2 After Pre-channel**

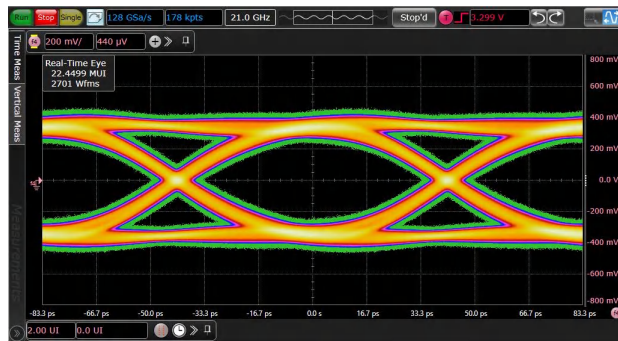

**Figure 8-7. 12Gbps Output Eye at TTP4 After Pre and Post Channels**

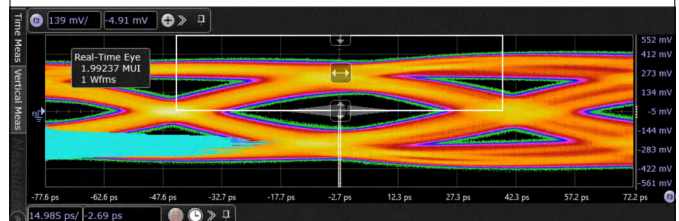

**Figure 8-8. 12Gbps Output Eye at TTP4\_EQ After Pre and Post Channels**

### 8.3 Typical Sink-Side Application

Figure 8-9 shows a schematic representation of what is considered a standard sink implementation.

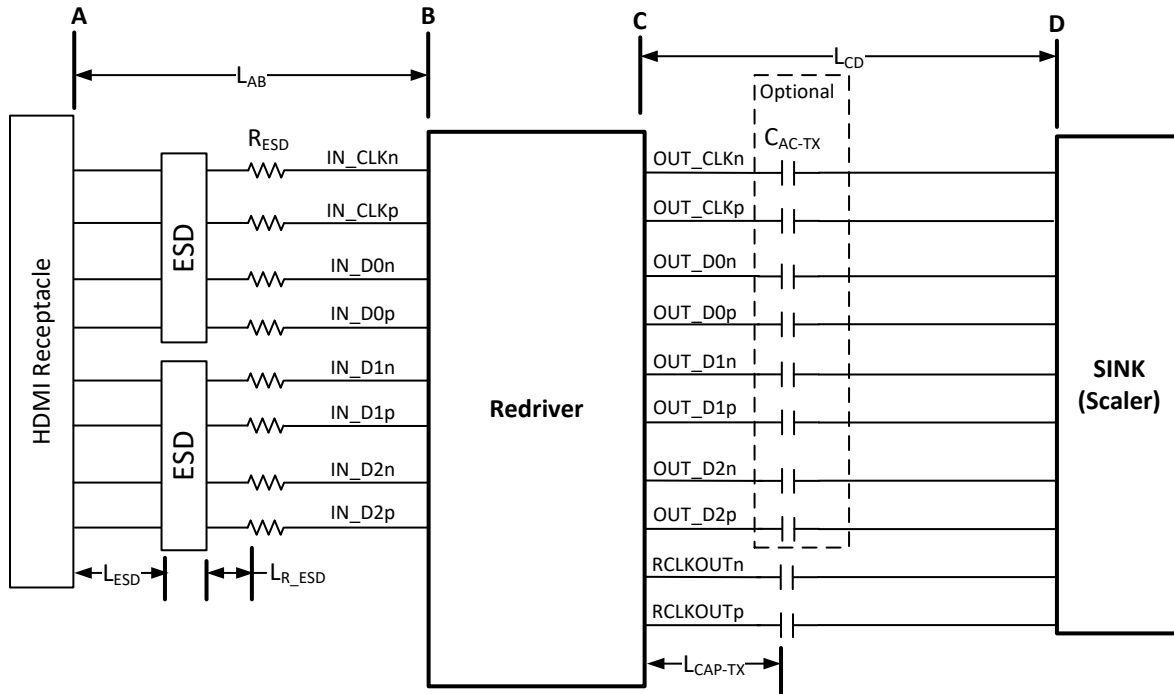

Figure 8-9. TMDS1204 in Sink Side Application

8.3.1 Design Requirements

Table 8-5. Design Parameters

Design Parameter	Value
V <sub>CC</sub>	3.3V (±5%)
V <sub>IO</sub> (1.2V, 1.8V, or 3.3V LVCMOS levels)	3.3V
Maximum HDMI 2.1 FRL Datarate (6, 8, 10, or 12Gbps)	12Gbps
Pin-strap or I2C mode (if I2C, then MODE = "F").	Pin-strap
Pin Strap Mode.(MODE = "0", "R" or "1").	Mode = "1" (Adaptive EQ)
DDC Snoop Feature. (Y/N). Required when in pin strap. Optional in I2C mode.	Yes
SWAP function (Y / N). In pin strap mode controlled by SDA/CFG1 pin.	No. SDA/CFG1 pin = L.
HPD_IN to HPD_OUT Level Shifter Support (Y / N)	No, then HPD_OUT can be left floating.
Pre-Channel Length (Table 8-6 lists the length restrictions)	Length = 1 inches; Width = 4 mil. (≈ 1dB at 6GHz insertion loss)
Post-Channel Length (Table 8-6 lists the length restrictions)	Length = 6 inches; Width = 4 mil (≈ 6dB at 6GHz insertion loss)
Limited or linear redriver mode?	Linear redriver (LINEAR_EN pin = "F") recommended in sink application
TX is DC or AC-coupled to HDMI receptacle?	AC-coupled. AC_EN pin = High.
RX EQ (16 possible values. Value chosen based on pre-channel length).	EQ1 pin: "0" ADDR/EQ0 pin: "1" (2.7dB)
CTLE Map (Map A, Map B or Map C). In pre-strap controlled by CTLEMAP_SEL pin.	For Sink application recommend Map B or C.
TX pre-emphasis. In pre-strap mode controlled by TXPRE pin. TX pre-emphasis control not supported in linear redriver mode.	Float TXPRE pin.
TX Swing. In pre-strap mode controlled by TXSWG pin.	Default TX swing level. Float TXSWG pin.
Fan-out Buffer support (Y / N)	Typically only used with a FPGA. If feature needed in pin-strap mode, then MODE must be set to "R".

**Table 8-6. Sink Layout and Component Placement Constraints**

Symbol	Parameter	Condition	Min	Typ	Max	Units
R <sub>ESD</sub>	External series resistor between ESD component and TMDS1204		0		2.5	Ω
L <sub>AB</sub> <sup>(1) (2)</sup>	PCB trace length from receptacle to TMDS1204		0.75		2	inches
L <sub>INTRA-AB</sub>	Intra-pair skew from receptacle to TMDS1204				2	mil
L <sub>CD</sub> <sup>(1)</sup>	PCB trace length from TMDS1204 to sink		1		6	inches
L <sub>INTRA-CD</sub>	Intra-pair skew from TMDS1204 to sink				2	mil
L <sub>CAP-TX</sub>	PCB trace length from TMDS1204 to external C <sub>AC-TX</sub> capacitor		0.3			inches
L <sub>ESD</sub>	PCB trace length from ESD component to receptacle				0.5	inches
L <sub>R_ESD</sub>	PCB trace length from R <sub>ESD</sub> to ESD component				0.25	inches
L <sub>INTER-PAIR</sub> <sup>(3)</sup>	Inter-pair skew between all four channels (D0, D1, D2, and CLK)				0.10	inches
IL <sub>PCB</sub>	PCB trace insertion loss		0.1		0.17	dB / inch /GHz
Z <sub>PCB_AB</sub>	Differential impedance of L <sub>AB</sub>		90		110	Ω
Z <sub>PCB_CD</sub>	Differential impedance of L <sub>CD</sub>		90		110	Ω
VIA <sub>AB</sub>	Number of vias between receptacle and TMDS1204				1	VIA
VIA <sub>CD</sub>	Number of vias between sink and TMDS1204				2	VIA
XTALK	Differential crosstalk between adjacent differential pairs on PCB.	≤ 3GHz			-24	dB

- (1) Maximum distance assumes PCB trace insertion loss meets IL<sub>PCB</sub> requirement. If PCB trace insertion loss exceeds the maximum limit, then distance needs to be reduced.
- (2) Minimum distance assumes PCB trace insertion loss meets IL<sub>PCB</sub> requirement. If PCB trace insertion loss is less than the minimum limit, then distance needs to be increased.
- (3) Calculation of channel length is the sum of L<sub>AB</sub> and L<sub>CD</sub>.

### 8.3.2 Detailed Design Procedures

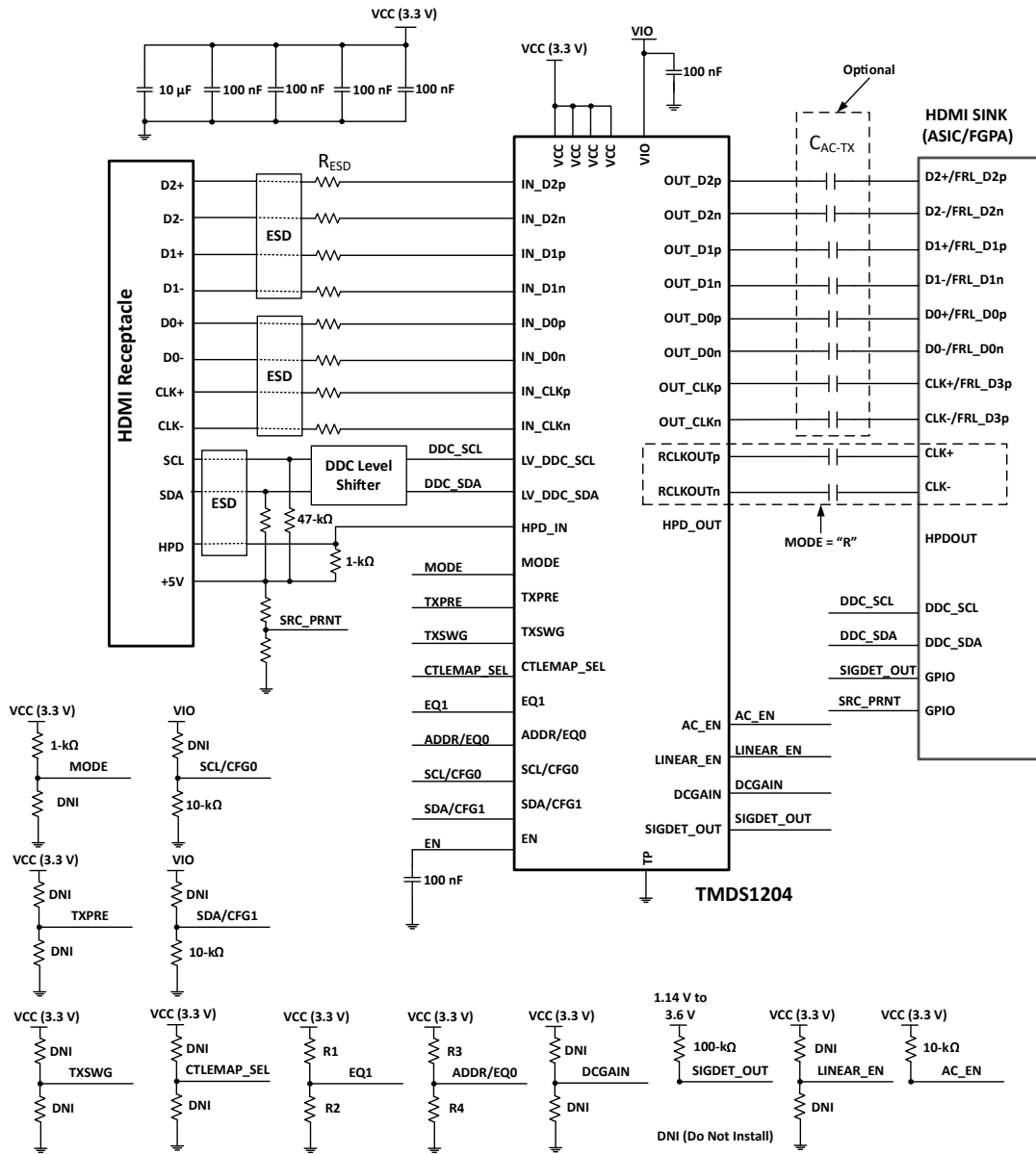

Figure 8-10. TMDS1204 in Sink Application Schematics

## 8.4 Power Supply Recommendations

### 8.4.1 Supply Decoupling

Texas Instruments recommends a single bulk capacitor of 10-µF on the V<sub>CC</sub> supply. Along with the bulk capacitor, Texas Instruments recommends a 0.1-µF decoupling capacitor on each TMDS1204 V<sub>CC</sub> pin that is placed as close to the V<sub>CC</sub> pin as possible. Figure 8-10 shows an example.

## 8.5 Layout

### 8.5.1 Layout Guidelines

For the TMDS1204 on a high-K board, it is required to solder the PowerPAD™ onto the thermal land to ground. A thermal land is the area of solder-tinned-copper underneath the PowerPAD package. On a high-K board, the TMDS1204 can operate over the full temperature range by soldering the PowerPAD onto the thermal land. For the device to operate across the temperature range on a low-K board, a 1-oz Cu trace connecting the GND pins to the thermal land must be used. A simulation shows  $R_{\theta JA} = 30.9^{\circ}\text{C/W}$  allowing 950-mW power dissipation at 70°C ambient temperature. For information about a general PCB design guide for PowerPAD packages, refer to the [PowerPAD Thermally Enhanced Package](#) application report. TI recommends using a four layer stack up at a minimum to accomplish a low-EMI PCB design. TI recommends four layers as the TMDS1204 is a single voltage rail device.

- Routing the high-speed TMDS traces on the top layer avoids the use of vias (and the introduction of their inductance) and allows for clean interconnects from the HDMI connectors to the Redriver inputs and outputs. It is important to match the electrical length of these high speed traces to minimize both inter-pair and intra-pair skew.
- Placing a solid ground plane next to the high-speed single layer establishes controlled impedance for transmission link interconnects and provides an excellent low-inductance path for the return current flow.
- Placing a power plane next to the ground plane creates an additional high-frequency bypass capacitance.
- Routing slower speed control signals on the bottom layer allows for greater flexibility as these signal links usually have margin to tolerate discontinuities such as vias.
- If an additional supply voltage plane or signal layer is needed, add a second power or ground plane system to the stack to keep symmetry. This makes the stack mechanically stable and prevents it from warping. Also the power and ground plane of each power system can be placed closer together, thus increasing the high frequency bypass capacitance significantly.
- To minimize crosstalk between adjacent differential pairs, the distance between the differential pairs should be at least five times longer than the trace width (5W rule). For the clock differential pair, the distance should be increased to 8W or 10W.

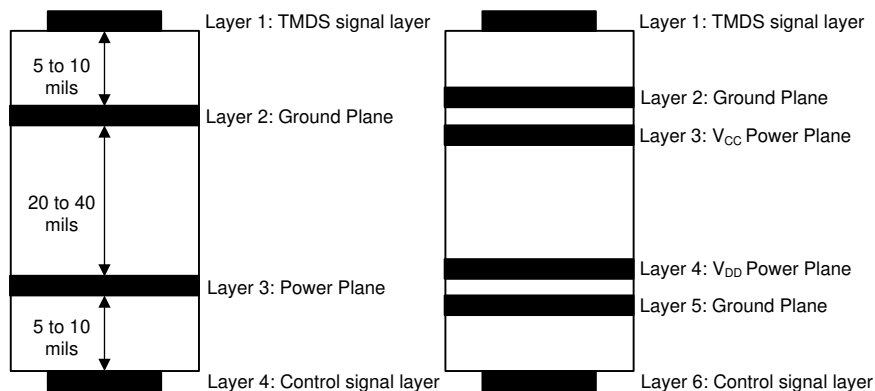

**Figure 8-11. Recommended 4 or 6-Layer PCB Stack**

### 8.5.2 Layout Example

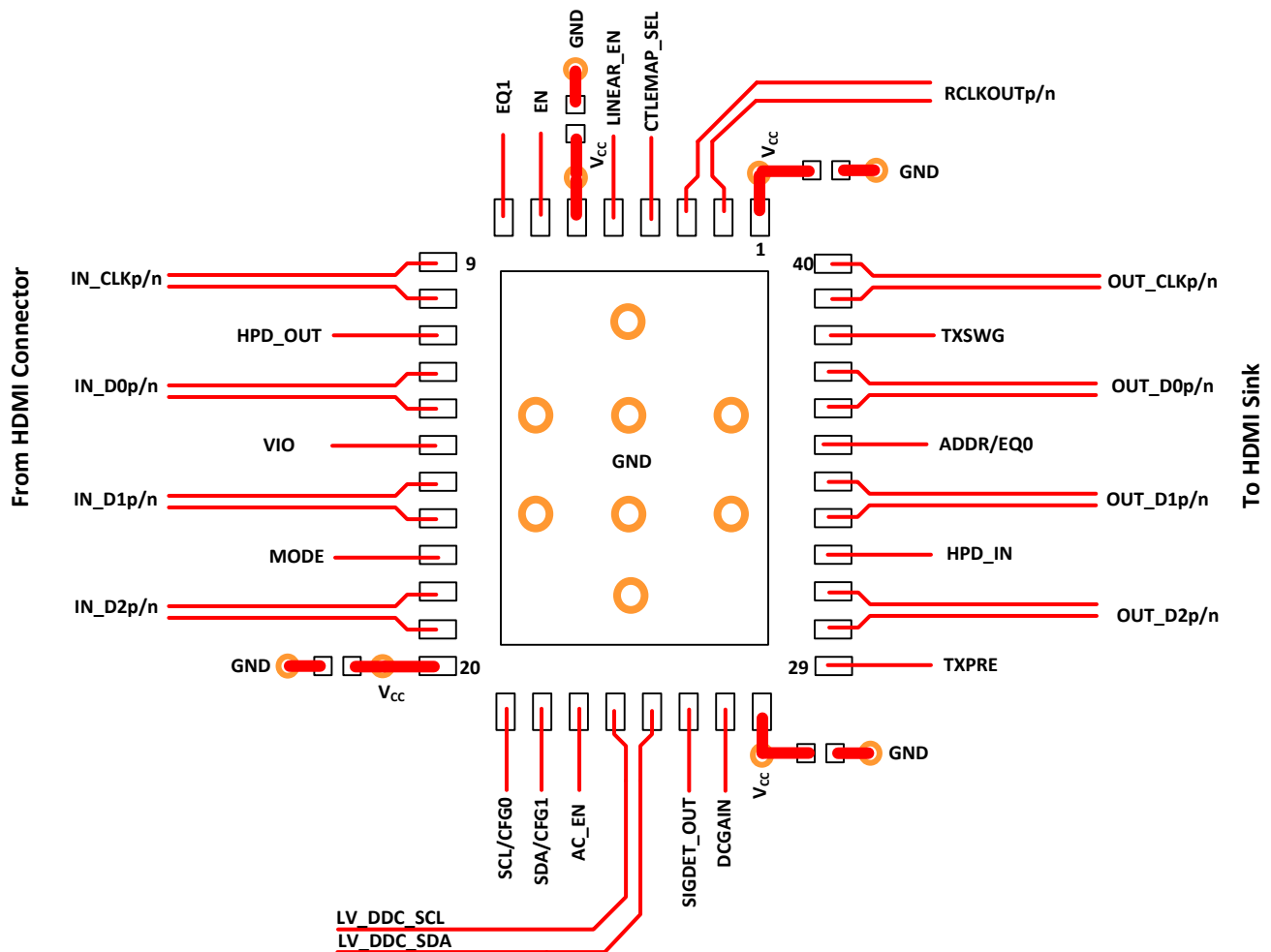

The differential input lanes and differential output lanes should be separated as close to the TMDS1204 as feasible to minimize crosstalk. Adding a ground flood plain between each differential lane further reduces crosstalk and thus improves signal integrity at high speed data rates.

Figure 8-12. Sink Example Layout

## 9 Device and Documentation Support

### 9.1 Documentation Support

#### 9.1.1 Related Documentation

For related documentation, see the following:

- Texas Instruments, [PowerPAD Thermally Enhanced Package application report](#)

### 9.2 Receiving Notification of Documentation Updates

To receive notification of documentation updates, navigate to the device product folder on [ti.com](#). Click on *Notifications* to register and receive a weekly digest of any product information that has changed. For change details, review the revision history included in any revised document.

### 9.3 Support Resources

[TI E2E™ support forums](#) are an engineer's go-to source for fast, verified answers and design help — straight from the experts. Search existing answers or ask your own question to get the quick design help you need.

Linked content is provided "AS IS" by the respective contributors. They do not constitute TI specifications and do not necessarily reflect TI's views; see TI's [Terms of Use](#).

### 9.4 Trademarks

HDMI™ is a trademark of HDMI Licensing, LLC.

Blu-ray™ is a trademark of Blu-ray Disc Association (BDA).

PowerPAD™ and TI E2E™ are trademarks of Texas Instruments.

TMDS® is a registered trademark of Silicon Image, Inc.

All trademarks are the property of their respective owners.

### 9.5 Electrostatic Discharge Caution



This integrated circuit can be damaged by ESD. Texas Instruments recommends that all integrated circuits be handled with appropriate precautions. Failure to observe proper handling and installation procedures can cause damage.

ESD damage can range from subtle performance degradation to complete device failure. Precision integrated circuits may be more susceptible to damage because very small parametric changes could cause the device not to meet its published specifications.

### 9.6 Glossary

[TI Glossary](#) This glossary lists and explains terms, acronyms, and definitions.

## 10 Revision History

NOTE: Page numbers for previous revisions may differ from page numbers in the current version.

Changes from Revision * (August 2022) to Revision A (April 2024)	Page
• Updated the <i>Device Information</i> table to include ambient temperature.....	1
• Corrected swap of R and F in EQ1 pin column in <i>Receiver EQ Settings When GLOBAL_DCG = 0x2</i> table ..	26
• Added <i>DisplayPort</i> section.....	34

## 11 Mechanical, Packaging, and Orderable Information

The following pages include mechanical, packaging, and orderable information. This information is the most current data available for the designated devices. This data is subject to change without notice and revision of this document. For browser-based versions of this data sheet, refer to the left-hand navigation.

**PACKAGING INFORMATION**

Orderable part number	Status (1)	Material type (2)	Package   Pins	Package qty   Carrier	RoHS (3)	Lead finish/ Ball material (4)	MSL rating/ Peak reflow (5)	Op temp (°C)	Part marking (6)
<a href="#">TMDS1204IRNQR</a>	Active	Production	WQFN (RNQ)   40	3000   LARGE T&R	Yes	NIPDAU	Level-1-260C-UNLIM	-40 to 85	TMD04
TMDS1204IRNQR.B	Active	Production	WQFN (RNQ)   40	3000   LARGE T&R	Yes	NIPDAU	Level-1-260C-UNLIM	-40 to 85	TMD04
<a href="#">TMDS1204IRNQT</a>	Active	Production	WQFN (RNQ)   40	250   SMALL T&R	Yes	NIPDAU	Level-1-260C-UNLIM	-40 to 85	TMD04
TMDS1204IRNQT.B	Active	Production	WQFN (RNQ)   40	250   SMALL T&R	Yes	NIPDAU	Level-1-260C-UNLIM	-40 to 85	TMD04
<a href="#">TMDS1204RNQR</a>	Active	Production	WQFN (RNQ)   40	3000   LARGE T&R	Yes	NIPDAU	Level-1-260C-UNLIM	0 to 70	TMD04
TMDS1204RNQR.B	Active	Production	WQFN (RNQ)   40	3000   LARGE T&R	Yes	NIPDAU	Level-1-260C-UNLIM	-40 to 85	TMD04
<a href="#">TMDS1204RNQT</a>	Active	Production	WQFN (RNQ)   40	250   SMALL T&R	Yes	NIPDAU	Level-1-260C-UNLIM	0 to 70	TMD04
TMDS1204RNQT.B	Active	Production	WQFN (RNQ)   40	250   SMALL T&R	Yes	NIPDAU	Level-1-260C-UNLIM	-40 to 85	TMD04

(1) **Status:** For more details on status, see our [product life cycle](#).

(2) **Material type:** When designated, preproduction parts are prototypes/experimental devices, and are not yet approved or released for full production. Testing and final process, including without limitation quality assurance, reliability performance testing, and/or process qualification, may not yet be complete, and this item is subject to further changes or possible discontinuation. If available for ordering, purchases will be subject to an additional waiver at checkout, and are intended for early internal evaluation purposes only. These items are sold without warranties of any kind.

(3) **RoHS values:** Yes, No, RoHS Exempt. See the [TI RoHS Statement](#) for additional information and value definition.

(4) **Lead finish/Ball material:** Parts may have multiple material finish options. Finish options are separated by a vertical ruled line. Lead finish/Ball material values may wrap to two lines if the finish value exceeds the maximum column width.

(5) **MSL rating/Peak reflow:** The moisture sensitivity level ratings and peak solder (reflow) temperatures. In the event that a part has multiple moisture sensitivity ratings, only the lowest level per JEDEC standards is shown. Refer to the shipping label for the actual reflow temperature that will be used to mount the part to the printed circuit board.

(6) **Part marking:** There may be an additional marking, which relates to the logo, the lot trace code information, or the environmental category of the part.

Multiple part markings will be inside parentheses. Only one part marking contained in parentheses and separated by a "~" will appear on a part. If a line is indented then it is a continuation of the previous line and the two combined represent the entire part marking for that device.

**Important Information and Disclaimer:** The information provided on this page represents TI's knowledge and belief as of the date that it is provided. TI bases its knowledge and belief on information provided by third parties, and makes no representation or warranty as to the accuracy of such information. Efforts are underway to better integrate information from third parties. TI has taken and continues to take reasonable steps to provide representative and accurate information but may not have conducted destructive testing or chemical analysis on incoming materials and chemicals. TI and TI suppliers consider certain information to be proprietary, and thus CAS numbers and other limited information may not be available for release.

In no event shall TI's liability arising out of such information exceed the total purchase price of the TI part(s) at issue in this document sold by TI to Customer on an annual basis.

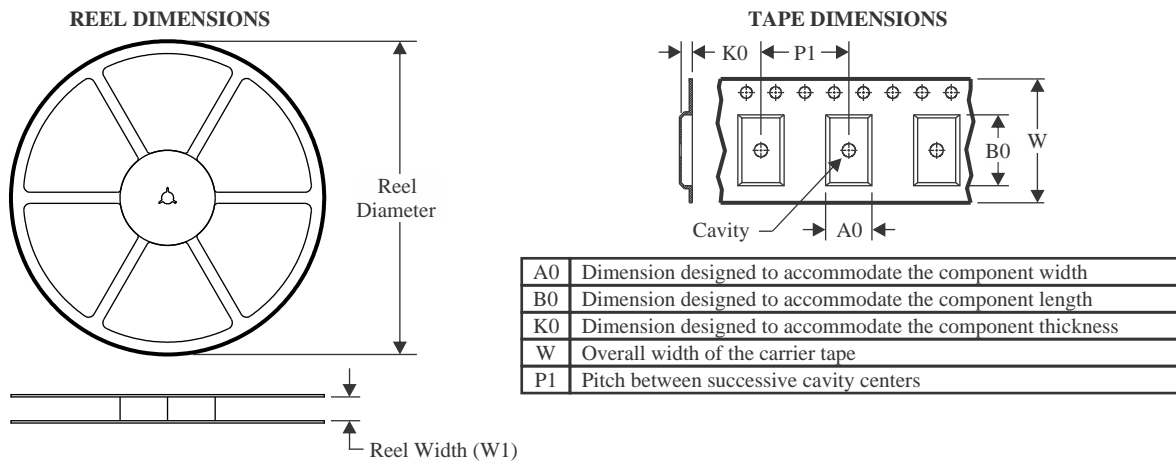
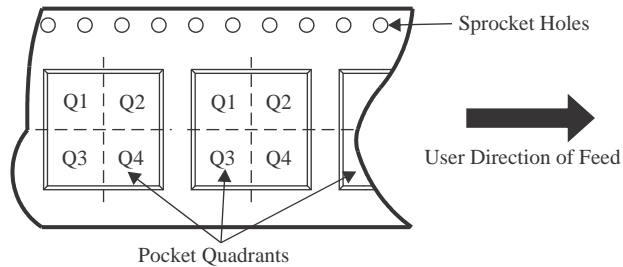
**TAPE AND REEL INFORMATION**

**QUADRANT ASSIGNMENTS FOR PIN 1 ORIENTATION IN TAPE**

\*All dimensions are nominal

Device	Package Type	Package Drawing	Pins	SPQ	Reel Diameter (mm)	Reel Width W1 (mm)	A0 (mm)	B0 (mm)	K0 (mm)	P1 (mm)	W (mm)	Pin1 Quadrant
TMDS1204IRNQR	WQFN	RNQ	40	3000	330.0	12.4	4.3	6.3	1.1	8.0	12.0	Q2
TMDS1204IRNQT	WQFN	RNQ	40	250	180.0	12.4	4.3	6.3	1.1	8.0	12.0	Q2
TMDS1204RNQR	WQFN	RNQ	40	3000	330.0	12.4	4.3	6.3	1.1	8.0	12.0	Q2
TMDS1204RNQT	WQFN	RNQ	40	250	180.0	12.4	4.3	6.3	1.1	8.0	12.0	Q2

**TAPE AND REEL BOX DIMENSIONS**

\*All dimensions are nominal

Device	Package Type	Package Drawing	Pins	SPQ	Length (mm)	Width (mm)	Height (mm)
TMDS1204IRNQR	WQFN	RNQ	40	3000	367.0	367.0	35.0
TMDS1204IRNQT	WQFN	RNQ	40	250	210.0	185.0	35.0
TMDS1204RNQR	WQFN	RNQ	40	3000	367.0	367.0	35.0
TMDS1204RNQT	WQFN	RNQ	40	250	210.0	185.0	35.0



# EXAMPLE BOARD LAYOUT

**RNQ0040A**

**WQFN - 0.8 mm max height**

PLASTIC QUAD FLATPACK - NO LEAD

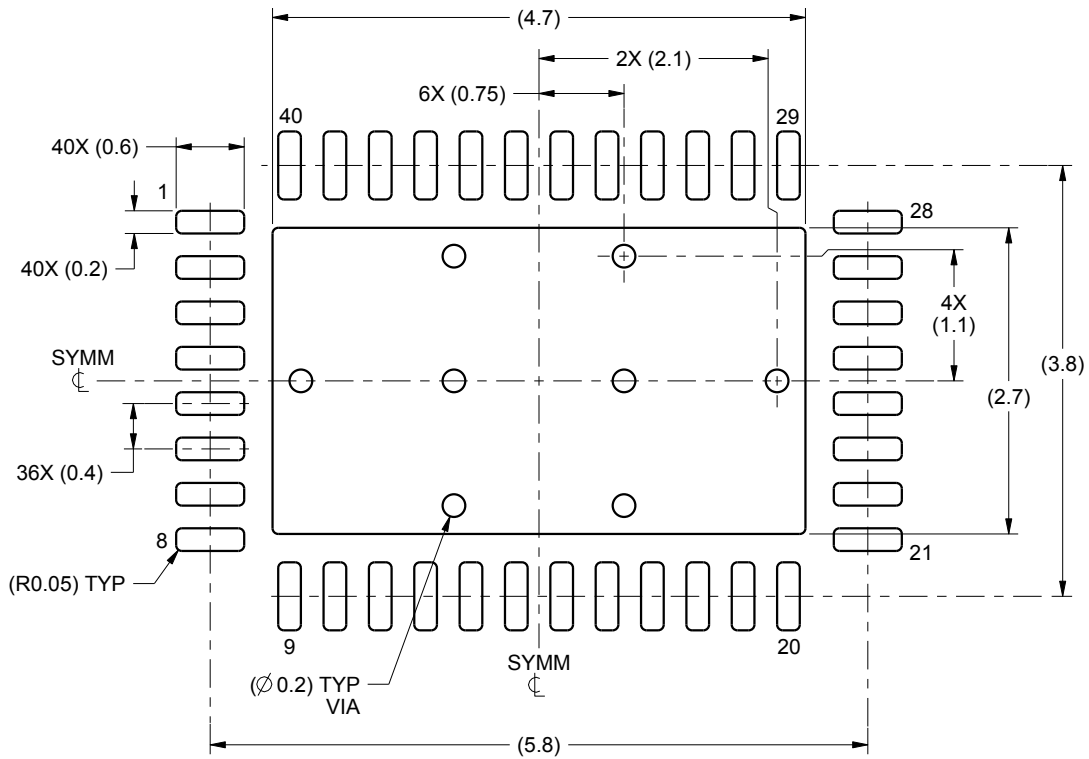

LAND PATTERN EXAMPLE  
SCALE:15X

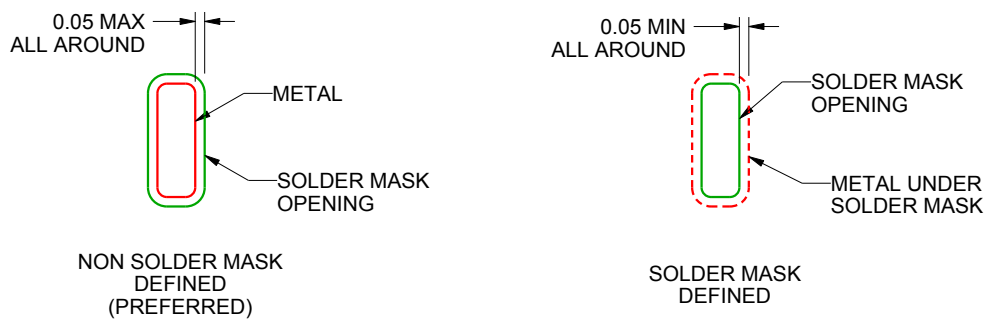

SOLDER MASK DETAILS

4222125/B 01/2016

NOTES: (continued)

4. This package is designed to be soldered to a thermal pad on the board. For more information, see Texas Instruments literature number SLUA271 ([www.ti.com/lit/slua271](http://www.ti.com/lit/slua271)).

# EXAMPLE STENCIL DESIGN

RNQ0040A

WQFN - 0.8 mm max height

PLASTIC QUAD FLATPACK - NO LEAD

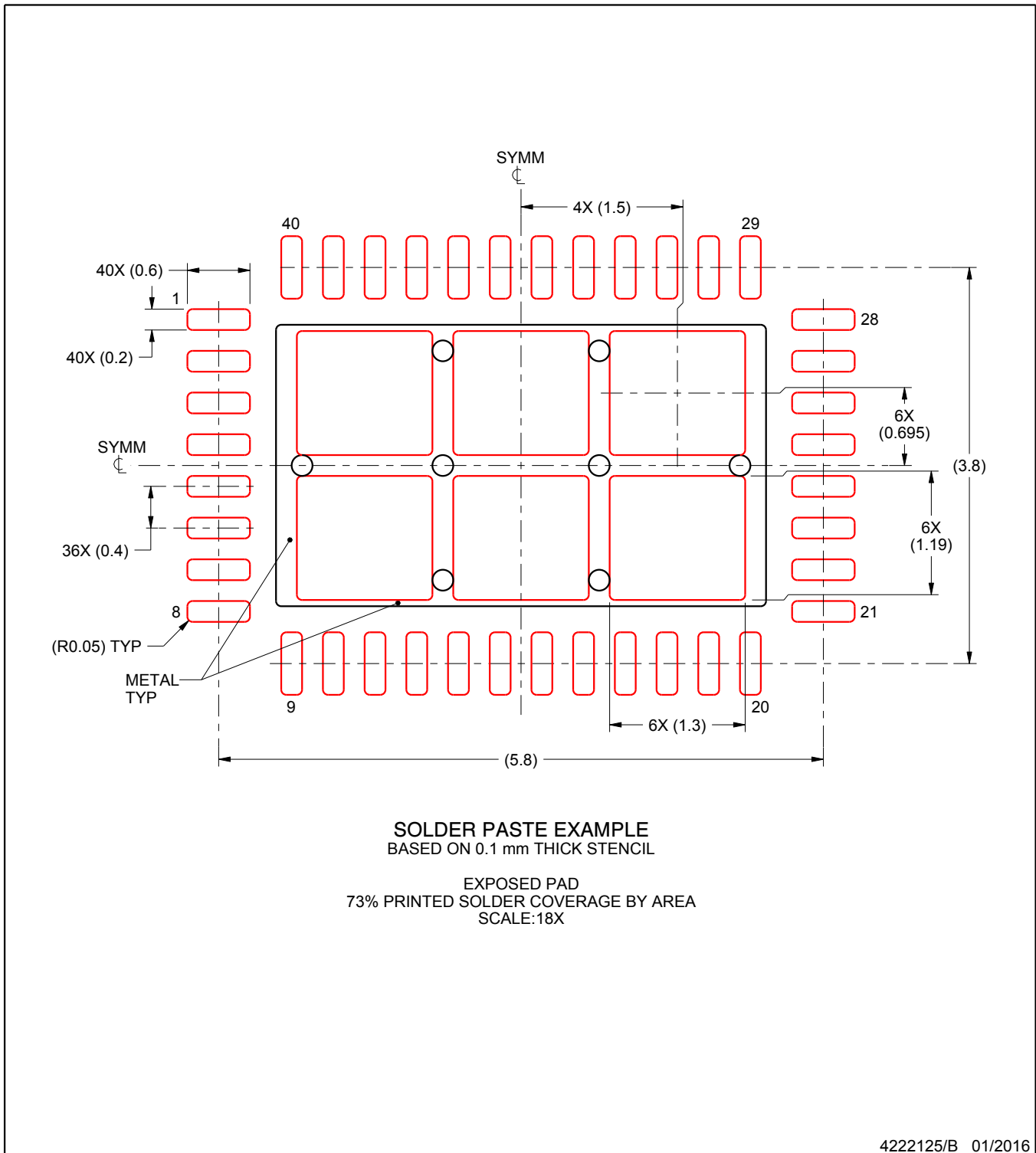

NOTES: (continued)

5. Laser cutting apertures with trapezoidal walls and rounded corners may offer better paste release. IPC-7525 may have alternate design recommendations.

## IMPORTANT NOTICE AND DISCLAIMER

TI PROVIDES TECHNICAL AND RELIABILITY DATA (INCLUDING DATA SHEETS), DESIGN RESOURCES (INCLUDING REFERENCE DESIGNS), APPLICATION OR OTHER DESIGN ADVICE, WEB TOOLS, SAFETY INFORMATION, AND OTHER RESOURCES "AS IS" AND WITH ALL FAULTS, AND DISCLAIMS ALL WARRANTIES, EXPRESS AND IMPLIED, INCLUDING WITHOUT LIMITATION ANY IMPLIED WARRANTIES OF MERCHANTABILITY, FITNESS FOR A PARTICULAR PURPOSE OR NON-INFRINGEMENT OF THIRD PARTY INTELLECTUAL PROPERTY RIGHTS.

These resources are intended for skilled developers designing with TI products. You are solely responsible for (1) selecting the appropriate TI products for your application, (2) designing, validating and testing your application, and (3) ensuring your application meets applicable standards, and any other safety, security, regulatory or other requirements.

These resources are subject to change without notice. TI grants you permission to use these resources only for development of an application that uses the TI products described in the resource. Other reproduction and display of these resources is prohibited. No license is granted to any other TI intellectual property right or to any third party intellectual property right. TI disclaims responsibility for, and you will fully indemnify TI and its representatives against, any claims, damages, costs, losses, and liabilities arising out of your use of these resources.

TI's products are provided subject to [TI's Terms of Sale](#) or other applicable terms available either on [ti.com](https://www.ti.com) or provided in conjunction with such TI products. TI's provision of these resources does not expand or otherwise alter TI's applicable warranties or warranty disclaimers for TI products.

TI objects to and rejects any additional or different terms you may have proposed.

Mailing Address: Texas Instruments, Post Office Box 655303, Dallas, Texas 75265

Copyright © 2025, Texas Instruments Incorporated