

TMP144 Low-Power, Digital Temperature Sensor With SMAART Wire™ / UART Interface

1 Features

- Multiple Device Access (MDA):
 - Global read/write operations
- SMAART Wire™ / UART interface
- Resolution: 12-bit or 0.0625°C
- ±1°C maximum (–10°C to +100°C)
- ±2°C maximum (–40°C to +125°C)
- Low quiescent current:
 - 3-μA active I_Q at 0.25 Hz
 - 0.6-μA shutdown
- Supply range: 1.4 V to 3.6 V
- Push-pull digital output
- Package:
 - 0.76 mm × 0.96 mm, 150-μm maximum height, 4-ball YMT (DSBGA)
 - 0.76 mm × 0.96 mm, 310-μm maximum height, 4-ball YBK (DSBGA)
 - 0.76 mm × 0.96 mm, 625-μm maximum height, 4-ball YFF (DSBGA)

2 Applications

- Handsets
- Smartphones
- Tablets
- LED Backlighting
- HDTVs
- Enterprise Servers
- Notebooks
- Medical

3 Description

The TMP144 digital output temperature sensor can read temperatures to a resolution of 0.0625°C.

The device has a SMAART Wire™ / UART interface that supports daisy-chain configurations. The interface also supports Multiple Device Access (MDA) commands that let the host communicate with multiple devices on the bus simultaneously. MDA commands are used as an alternative to sending individual commands to each device on the bus. Up to 16 TMP144 devices can be attached together serially and can be read by the host computer.

The TMP144 device is designed for space-constrained, power-sensitive applications with multiple temperature measurement zones that must be monitored. The device is specified for operation over a temperature range of –40°C to 125°C and is available in three different 4-ball, low-height wafer chip-scale package (DSBGA) options. The YMT package of the device has a height of 150 μm, which is 40% thinner than a 0201 resistor. The thinner YMT package can be placed under heat-dissipating components on the system for better accuracy and faster thermal response times.

Package Information⁽¹⁾

PART NUMBER	PACKAGE	PACKAGE SIZE (NOM) ⁽²⁾
TMP144	YFF (DSBGA, 4)	0.76 mm × 0.96 mm
	YMT (DSBGA, 4)	0.76 mm × 0.96 mm
	YBK (DSBGA, 4)	0.76 mm × 0.96 mm

(1) For all available packages, see the orderable addendum at the end of the data sheet.

(2) The package size (length × width) is a nominal value and includes pins, where applicable.



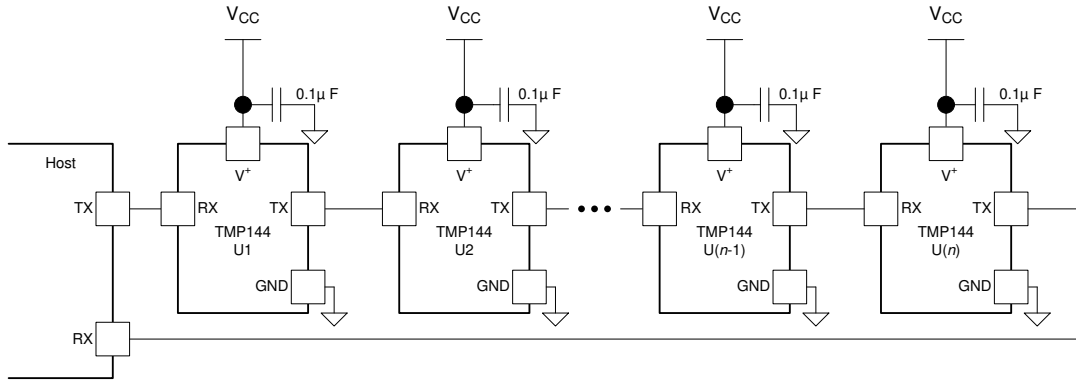

Up to 16 TMP144 devices can be configured as a daisy-chain. (See [Device Nomenclature](#))

Simplified Application

Table of Contents

1 Features	1	7.4 Device Functional Modes.....	11
2 Applications	1	7.5 SMAART Wire™ / UART Interface.....	14
3 Description	1	7.6 Register Maps.....	20
4 Revision History	3	8 Application and Implementation	24
5 Pin Configuration and Functions	4	8.1 Application Information.....	24
6 Specifications	5	8.2 Typical Application.....	24
6.1 Absolute Maximum Ratings.....	5	8.3 Power Supply Recommendations.....	25
6.2 ESD Ratings.....	5	8.4 Layout.....	25
6.3 Recommended Operating Conditions.....	5	9 Device and Documentation Support	27
6.4 Thermal Information.....	5	9.1 Device Support.....	27
6.5 Electrical Characteristics.....	5	9.2 Receiving Notification of Documentation Updates.....	27
6.6 UART Interface Timing.....	7	9.3 Support Resources.....	27
6.7 Timing Diagrams.....	7	9.4 Trademarks.....	27
6.8 Typical Characteristics.....	8	9.5 Electrostatic Discharge Caution.....	27
7 Detailed Description	9	9.6 Glossary.....	27
7.1 Overview.....	9	10 Mechanical, Packaging, and Orderable Information	27
7.2 Functional Block Diagram.....	9		
7.3 Feature Description.....	10		

4 Revision History

NOTE: Page numbers for previous revisions may differ from page numbers in the current version.

Changes from Revision B (April 2021) to Revision C (September 2023) Page

• Added YBK package option.....	1
---------------------------------	---

Changes from Revision A (February 2021) to Revision B (April 2021) Page

• Removed Advanced Information note from YMT package.....	1
• Updated thermal information for YMT package.....	5
• Added typical value for pin capacitance.....	5
• Added active conversion current consumption limit values.....	5
• Added Figure 6-5 to the <i>Typical Characteristics</i> section.....	8

Changes from Revision * (October 2018) to Revision A (February 2021) Page

• Changed data sheet status from Production Data to Production Mixed.....	1
• Updated the numbering format for tables, figures, and cross-references throughout the document.....	1
• Added Advanced Information YMT package.....	4
• Updated absolute max supply voltage from 3.6V to 4.0V.....	5
• Updated TX pin absolute max from (V+) + 0.3 V to (V+) + 0.3 and ≤ 4 V.....	5
• Added digital temperature output section for result readout with different ETM mode setting.....	10
• Updated the communication protocol description.....	14
• Added command byte value table.....	14
• Added command flow for global software reset.....	15
• Added command flow for global initialization and address assignment.....	15
• Added command flow for global clear interrupt.....	17
• Added command flow for global read and write.....	17
• Added command flow for individual read and write.....	18
• Updated Register Map as per new format.....	20
• Updated temperature result register as a 16-bit value to map to the communication protocol.....	21
• Updated configuration register as a 16-bit value to map to the communication protocol.....	21
• Updated temperature low limit register as a 16-bit value to map to the communication protocol.....	22
• Updated temperature high limit register as a 16-bit value to map to the communication protocol.....	23

5 Pin Configuration and Functions

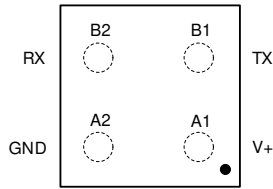

Not to scale

Figure 5-1. YFF and YBK Package 4-Pin DSBGA (Top View)

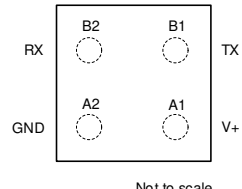

Not to scale

Figure 5-2. YMT Package 4-Pin DSBGA (Top View)

Table 5-1. Pin Functions

PIN		I/O ⁽¹⁾	DESCRIPTION
NAME	NO.		
GND	A2	G	Ground
RX	B2	I	Serial data input pin
TX	B1	O	Serial data output pin (push-pull output)
V+	A1	I	Supply voltage 1.4 V to 3.6 V

(1) I = Input, O = Output, G = Ground

6 Specifications

6.1 Absolute Maximum Ratings

Over free-air temperature range unless otherwise noted⁽¹⁾

		MIN	MAX	UNIT
Supply voltage	V+	-0.3	4.0	V
Input voltage	RX	-0.3	(V+) + 0.3 and ≤ 4	V
I/O current	TX		±15	mA
Operating junction temperature, T _J		-55	150	°C
Storage temperature, T _{stg}		-60	150	°C

- (1) Stresses beyond those listed under *Absolute Maximum Ratings* may cause permanent damage to the device. These are stress ratings only, which do not imply functional operation of the device at these or any other conditions beyond those indicated under *Recommended Operating Conditions*. Exposure to absolute-maximum-rated conditions for extended periods may affect device reliability.

6.2 ESD Ratings

			VALUE	UNIT
V _(ESD)	Electrostatic discharge	Human-body model (HBM), per ANSI/ESDA/JEDEC JS-001 ⁽¹⁾	±2000	V
		Charged-device model (CDM), per JEDEC specification JESD22-C101 ⁽²⁾	±1000	V

- (1) JEDEC document JEP155 states that 500-V HBM allows safe manufacturing with a standard ESD control process.
 (2) JEDEC document JEP157 states that 250-V CDM allows safe manufacturing with a standard ESD control process.

6.3 Recommended Operating Conditions

		MIN	NOM	MAX	UNIT
V+	Supply voltage	1.4	3.3	3.6	V
V _{I/O}	RX	0		V+	V
T _A	Operating ambient temperature	-40		125	°C

6.4 Thermal Information

THERMAL METRIC ⁽¹⁾		TMP144			UNIT
		YFF (DSBGA)	YMT (DSBGA)	YBK (DSBGA)	
		4 PINS	4 PINS	4 PINS	
R _{θJA}	Junction-to-ambient thermal resistance	188.5	167.3	180.2	°C/W
R _{θJC(top)}	Junction-to-case (top) thermal resistance	2.1	0.7	1.1	°C/W
R _{θJC(bot)}	Junction-to-case (bottom) thermal resistance	NA	NA	NA	°C/W
R _{θJB}	Junction-to-board thermal resistance	35.1	47.0	60	°C/W
ψ _{JT}	Junction-to-top characterization parameter	10.6	0.4	0.6	°C/W
ψ _{JB}	Junction-to-board characterization parameter	35.1	47.0	60	°C/W

- (1) For more information about traditional and new thermal metrics, see the *IC Package Thermal Metrics* application report, [SPRA953](#).

6.5 Electrical Characteristics

Over free-air temperature range and V+ = 1.4 V to 3.6 V (unless otherwise noted); Typical specifications are at T_A = 25°C and V+ = 3.3 V (unless otherwise noted)

PARAMETER	TEST CONDITIONS	MIN	TYP	MAX	UNIT
TEMPERATURE SENSOR					
T _{ERR} ⁽¹⁾	Temperature accuracy	V+ = 3.3 V, T _A = -10°C to 100 °C		±0.5	±1.0 °C
	Temperature accuracy	V+ = 1.4 V to 3.6 V, T _A = -40°C to 125°C		±1.0	±2.0 °C
PSR	DC power supply rejection	One-shot mode		±0.2	±0.5 °C/V

TMP144

SBOS891C – OCTOBER 2018 – REVISED SEPTEMBER 2023

Over free-air temperature range and $V_+ = 1.4\text{ V}$ to 3.6 V (unless otherwise noted); Typical specifications are at $T_A = 25^\circ\text{C}$ and $V_+ = 3.3\text{ V}$ (unless otherwise noted)

PARAMETER		TEST CONDITIONS	MIN	TYP	MAX	UNIT
T_{RES}	Temperature resolution	Including sign bit		12		Bits
		LSB		62.5		$m^\circ\text{C}$
t_{CONV}	Conversion time	One-shot mode		26	35	ms
t_{CONV_P}	Conversion Period	CR1 = 0, CR0 = 0 (default)		4		s
		CR1 = 0, CR0 = 1		1		s
		CR1 = 1, CR0 = 0		0.25		s
		CR1 = 1, CR0 = 1		0.125		s
DIGITAL INPUT/OUTPUT						
C_{IN}	Input capacitance			5		pF
V_{IH}	Input logic high level	RX	$0.7 \times (V_+)$		$(V_+) + 0.3$	V
V_{IL}	Input logic low level	RX	-0.5		$0.3 \times (V_+)$	V
I_{IN}	Input leakage current	$0 \leq V_{IN} \leq (V_+) + 0.3\text{ V}$	-1		1	μA
V_{OL}	Output low level	TX, $V_+ > 2\text{ V}$, $I_{OH} = 1\text{ mA}$	0		0.4	V
		TX, $V_+ < 2\text{ V}$, $I_{OH} = 1\text{ mA}$	0		$0.2 \times (V_+)$	V
V_{OH}	Output high level	TX, $V_+ > 2\text{ V}$, $I_{OL} = 1\text{ mA}$	$(V_+) - 0.4$		V_+	V
		TX, $V_+ < 2\text{ V}$, $I_{OL} = 1\text{ mA}$	$0.8 \times (V_+)$		V_+	V
POWER SUPPLY						
I_{DD_ACTI} V_E	Supply current during active conversion	$V_+ = 3.3\text{ V}$, Active Conversion, serial bus inactive		44	100	μA
I_{DD_AVG}	Average current consumption	$V_+ = 3.3\text{ V}$, CR1 = 0, CR0 = 0 (default)	Serial bus inactive	3	10	μA
			Serial bus active	53		
I_{DD_SB}	Standby current ⁽²⁾	$V_+ = 3.3\text{ V}$, Serial bus inactive		2.5	9.5	μA
I_{DD_SD}	Shutdown current	$V_+ = 3.3\text{ V}$, Serial bus inactive		0.6	5	μA
V_{POR}	Power-on reset threshold voltage	Supply rising		0.9		V
t_{RAMP_V} DD	V_{DD} ramp time requirements	Supply rising or falling			1	ms

(1) Does not include effects of self heating.

(2) Quiescent current between conversions

6.6 UART Interface Timing

Over free-air temperature range and V+ = 1.4 V to 3.6 V (unless otherwise noted)

		UART (8N1)		UNIT
		MIN	MAX	
	Baud Rate	4.8	114	kbps
t _R	Data rise time		0.5%	Baud
t _F	Data fall time		0.5%	Baud
	Jitter		±1	Baud

6.7 Timing Diagrams

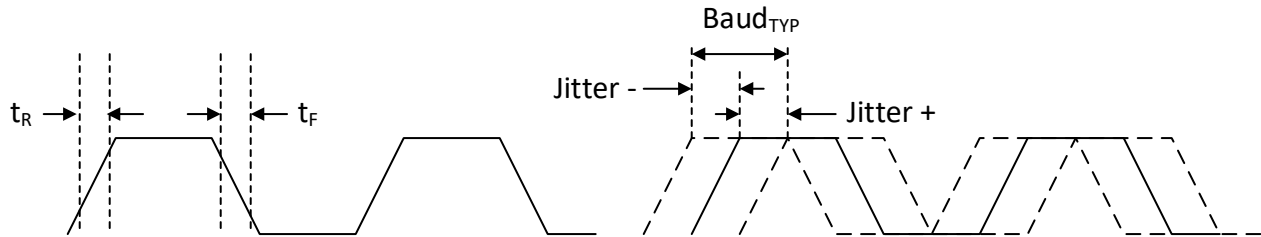

Figure 6-1. SMART Wire™ / UART Interface Timing Diagram

6.8 Typical Characteristics

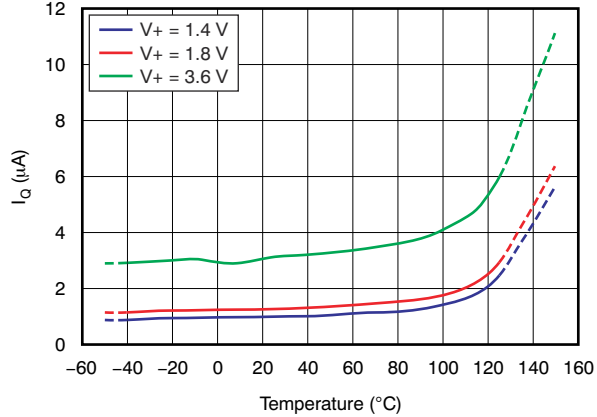

Figure 6-2. Typical Quiescent Current vs. Temperature

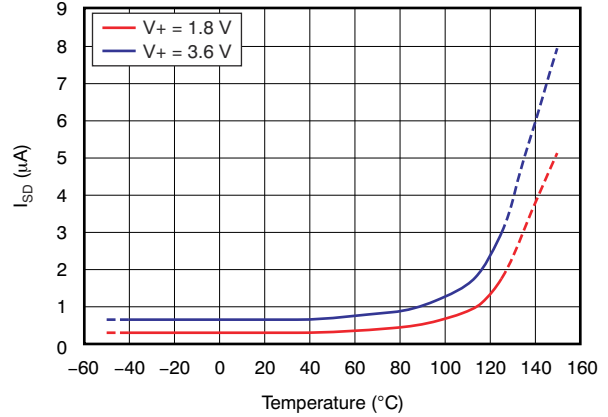

Figure 6-3. Shutdown Current vs. Temperature

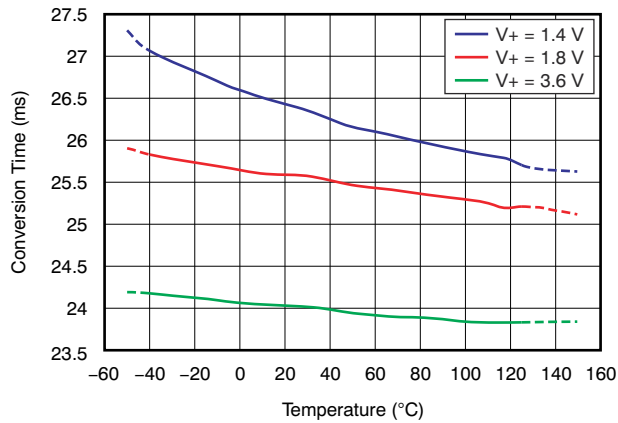

Figure 6-4. Conversion Time vs. Temperature

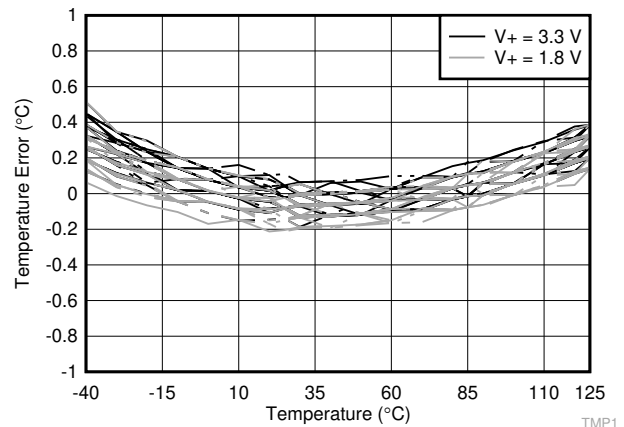

Figure 6-5. Temperature Error vs. Temperature (YFF Package)

7 Detailed Description

7.1 Overview

The TMP144 is a digital output temperature sensor in a wafer chip-scale package (WCSP) that is designed for thermal management and thermal profiling. The TMP144 includes a SMAART Wire™ / UART interface that can communicate in a daisy-chain loop with up to 16 devices on a single bus. The interface requires two pins from the host: the first device in the daisy-chain receives data from the host and the last device in the daisy-chain returns data to the host, closing the loop. In addition, the TMP144 can do multiple device access (MDA) commands that allow multiple TMP144 devices to respond to a single global bus command. MDA commands reduce communication time and power in a bus that contains multiple TMP144 devices. The operation of TMP144, is specified over a temperature range of -40°C to 125°C .

The TMP144 can also configure the bus in a transparent mode, where the input from the host is sent directly to the next device in the chain without delay. Additionally, the TMP144 can disconnect the chain and create a serial communication controlled by each TMP144 on the bus, thereby allowing each device to have configurable addressing and interrupt capabilities. The input pin, RX, is a high-impedance node. The output pin, TX, has an internal push-pull output stage that can drive the host to GND or V+.

After an initialization sequence, each device on the bus is programmed with its own unique interface address based upon its position in the chain, that allows it to respond to its own address. The devices can also respond to general commands that permit the user to read or write to all devices on the bus without the need to send individual addresses and commands to each device.

The temperature sensor in the TMP144 is the chip itself. Thermal paths run through the package bumps as well as the package. The lower thermal resistance of metal and the low height of the devices, causes the bumps and the topside to provide the dominant thermal paths to the sensing element on the device. To maintain accuracy in applications that require air or surface temperature measurement, care should be taken to isolate the package from ambient air temperature. A thermally-conductive adhesive can help to achieve accurate surface temperature measurement.

7.2 Functional Block Diagram

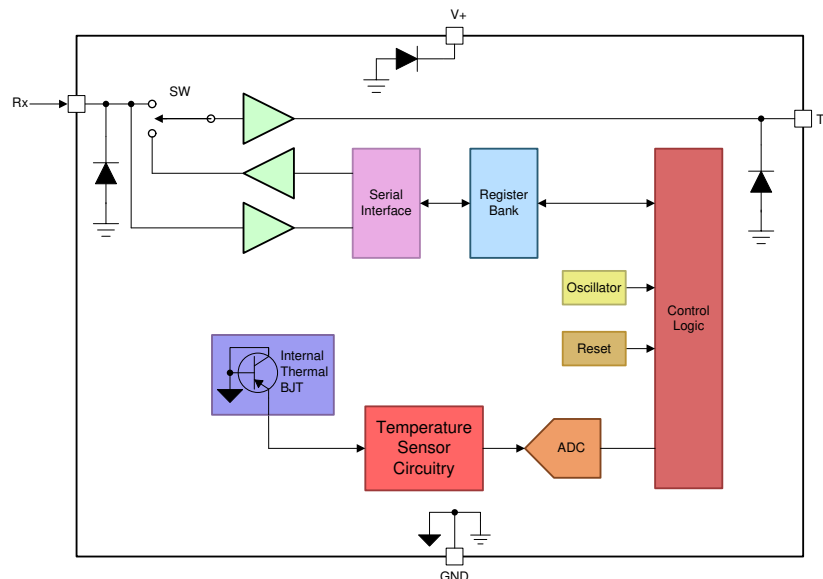

7.3 Feature Description

7.3.1 Power Up

After power-up or general-call reset, the TMP144 immediately starts a conversion as shown in Figure 7-1. The active conversion time (t_{ACT}) of the device is 26 ms (typical) and the first result is available after the conversion is complete in the [temperature result register](#).

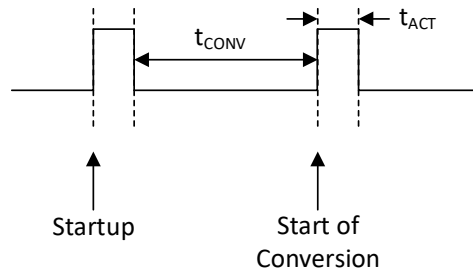

Figure 7-1. Conversion Start

7.3.2 Digital Temperature Output

The TMP144 by default provides a 12-bit digital output for each temperature conversion, which is stored in the temperature result register. The host application needs to read two bytes to obtain the data. Additionally, the application may program the ETM bit in the [configuration register](#) to get a 13-bit digital output. [Table 7-1](#) summarizes the temperature output format. One LSB equals 0.0625°C resolution.

Table 7-1. Temperature Data Format

TEMPERATURE (°C)	DIGITAL OUTPUT (ETM = 0)		DIGITAL OUTPUT (ETM = 1)	
	BINARY (T11-T0)	HEX	BINARY (T12-T0)	HEX
+150	0111 1111 1111	7FF	0 1001 0110 0000	0960
+127.9375	0111 1111 1111	7FF	0 0111 1111 1111	07FF
+125	0111 1101 0000	7D0	0 0111 1101 0000	07D0
+100	0110 0100 0000	640	0 0110 0100 0000	0640
+80	0101 0000 0000	500	0 0101 0000 0000	0500
+75	0100 1011 0000	4B0	0 0100 1011 0000	04B0
+50	0011 0010 0000	320	0 0011 0010 0000	0320
+25	0001 1001 0000	190	0 0001 1001 0000	0190
+0.0625	0000 0000 0001	001	0 0000 0000 0001	0001
0	0000 0000 0000	000	0 0000 0000 0000	0000
-0.0625	1111 1111 1111	FFF	1 1111 1111 1111	1FFF
-25	1110 0111 0000	E70	1 1110 0111 0000	1E70
-40	1101 1000 0000	D80	1 1101 1000 0000	1D80

7.3.3 Timeout Function

A timeout mechanism is implemented on the TMP144 to allow for re-synchronization of the SMAART Wire™ interface if synchronization between the host and the TMP144 is lost for 28 ms (typical). If the timeout period expires between the calibration byte and the command byte, between the command byte and a data byte, or between any data bytes, the TMP144 resets the SMAART Wire™ interface circuitry and waits for the baud rate calibration command to restart. Every time a byte is transmitted on the SMAART Wire™ interface, this timeout period restarts.

7.4 Device Functional Modes

7.4.1 Continuous Conversion Mode

When the TMP144 is in Continuous Conversion mode ($M1 = 1$), continuous conversions are performed at a rate determined by the conversion rate bits, CR[1:0], in the [configuration register](#). The TMP144 performs a single conversion, then powers down and waits for the appropriate delay set by CR[1:0].

7.4.2 Shutdown Mode

Shutdown mode saves maximum power by shutting down all device circuitry other than the serial interface, reducing the current consumption to typically less than 0.5 μ A. Shutdown mode is enabled when bits M[1:0] in the [configuration register](#) are set as "00". If there is an active conversion ongoing, the device completes the ongoing conversion, updates the temperature result register and shuts down.

7.4.3 One-Shot Mode

The TMP144 features a One-Shot Temperature Measurement mode. When the device is in Shutdown mode, writing 01 to bits M[1:0] in the [configuration register](#), starts a single temperature conversion. During the conversion, the bits M[1:0] read 01. The device returns to the shutdown state at the completion of the single conversion. After the conversion, bits M[1:0] read 00. This feature is useful for reducing power consumption in the TMP144 when continuous temperature monitoring is not required.

As a result of the short conversion time, the TMP144 can achieve a higher conversion rate. A single conversion typically takes 26 ms and an individual read can take place in less than 300 μ s. When using One-Shot mode, 30 or more conversions per second are possible.

7.4.4 Extended Temperature Mode

At power on, the TMP144 operates with a 12-bit temperature output. However, the TMP144 can be programmed to operate in Extended Temperature mode, by setting the ETM bit in the [configuration register](#) as '1'. When operating in extended temperature mode, the temperature result and temperature limit registers will be 13-bit instead of 12-bit. This extra bit increases the range of the measurement. As shown in [Table 7-1](#), with a 12-bit temperature, the maximum value is 7FFh or 127.9°C. With a 13-bit temperature value, however, the maximum value is FFFh or 255.9°C.

When the extended temperature mode is enabled, the EM bit for the temperature high limit register and temperature low limit registers is usable by the application. TI recommends that the user update the T_{HIGH} and T_{LOW} register limits because the added bit will effectively left shift and double the register value. This will double the corresponding temperature limit. However, if the application exits the ETM mode, by changing the bit from 1 to 0, this bit is not cleared. As a result, the limit will be right-shifted by 1 bit and halved unless the register values are updated by the application.

The ETM bit value is considered at the end of every conversion cycle, but the limit registers can be updated immediately after setting the bit to 1.

7.4.5 Temperature Alert Function

The TMP144 contains a temperature alert function that monitors the device temperature and compares the result to the values stored in the temperature limit registers to determine if the device temperature is within these set limits. As shown in [Figure 7-2](#), if the result of the temperature conversion is greater than the value in the [temperature high limit register](#), the flag-high bit (FH) in the [configuration register](#) is set to '1'. If the result of the temperature conversion register is less than the value in the [temperature low limit register](#), the flag-low (FL) in

the configuration register is set to '1'. The clearing of the flag bits depends on the setting of the latch bit (LC) in the configuration register.

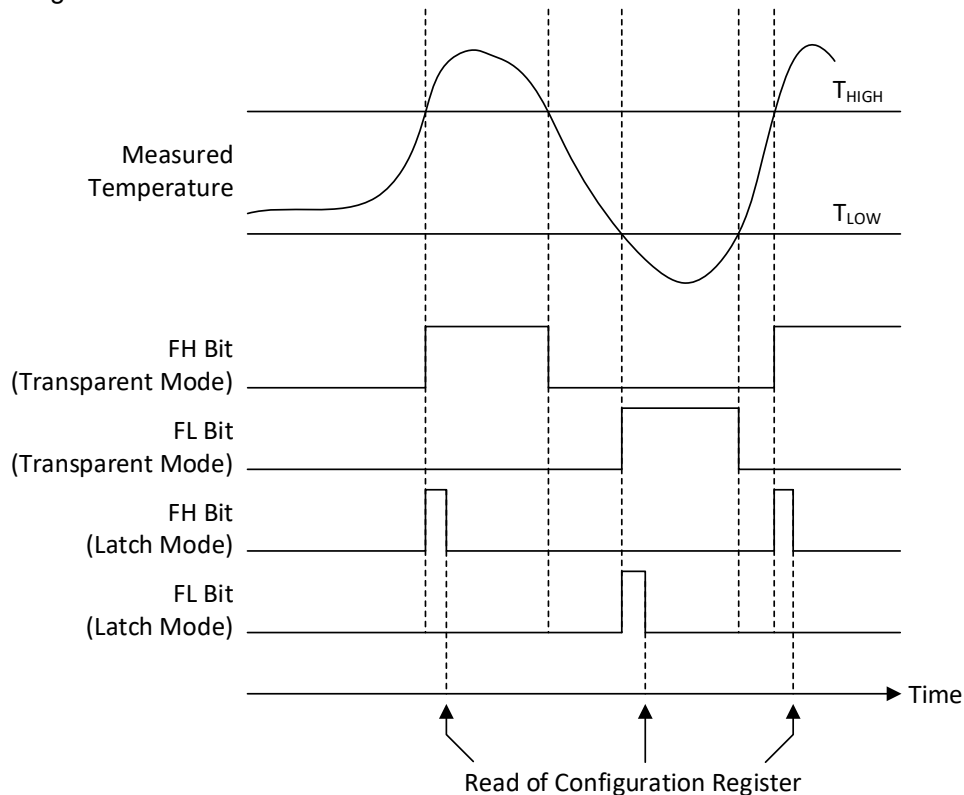

Figure 7-2. Temperature Flag Functional Diagram

The LC bit in the configuration register when set to '1' is used to latch the value of the flag bits (FH and FL) until the host issues a read command to the configuration register. The flag bits are set to '0' when a read command is received by the device.

The LC bit when configured as '0', configures the device to operate in transparent mode, where the flag bits (FH and FL) are cleared only when the result of the temperature conversion is within the temperature limits.

7.4.6 Interrupt Functionality

The TMP144 interrupts the host by disconnecting the bus and issuing an interrupt request by holding the bus low if all of following conditions are met as shown in [Figure 7-3](#).

- INT_EN in the [configuration register](#) is set to 1;
- The temperature result of the last conversion is greater than the value in the temperature high limit register or less than the value in the temperature low limit register (also indicated by a 1 in either FH or FL, respectively);
- The bus is logic high and idle for more than 28 ms.

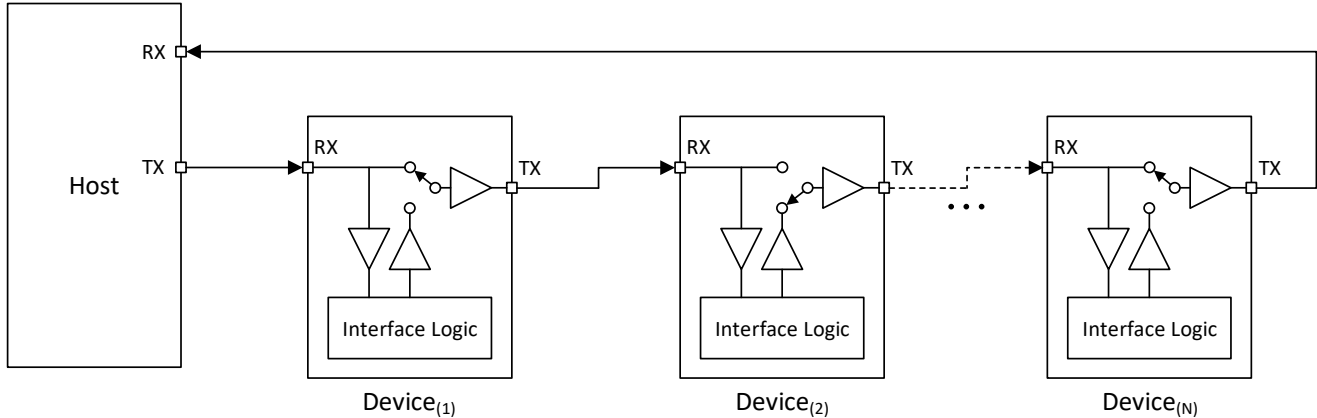

Figure 7-3. TMP144 Daisy-Chain: Bus Status During an Interrupt Request (Logic Low) From Second Device

The interrupt on the bus is latched regardless of the status of LC. Writing a 1 to INT_EN automatically sets the LC bit. The TMP144 holds the bus low until one of the following events happen:

- Global Interrupt Clear command is received.
- Global Software Reset command is received.
- A power-on reset event occurs.

Each of these events clears the INT_EN. The TMP144 does not issue future interrupts until the host writes sets the INT_EN in the configuration register to re-enable future interrupts.

In a system with enabled interrupts, it is possible for a TMP144 on the bus to issue an interrupt at the same time that the host starts a communication sequence. To avoid this scenario, TI recommends that the host should check the status on the receiving side of the bus after transmitting the calibration byte. If it is 1, then the host can continue with the communication. If it is 0, one of the TMP144 devices on the bus is issuing an alert and the host must transmit a Global Interrupt Clear command.

7.5 SMAART Wire™ / UART Interface

The TMP144 uses a TI proprietary, one-wire UART-compatible communication protocol called SMAART Wire™. The TMP144 has two dedicated pins for communication: TX and RX. Usually, these two pins are connected internally and the signal on the RX propagates to the TX, unless the device must send data on the bus or during address assignment and alert procedures.

The interface has built-in timeouts (typically 28 ms) that return the interface to a known state if communication is disrupted.

7.5.1 Communication Protocol

Each communication of the SMAART Wire™ / UART protocol consists of 8-bit word, transferred least significant bit (LSB) first. Each 8-bit word begins with a *Start* bit that is logic low, and ends with a *Stop* bit that is logic high. By using a Start bit and Stop bit for each 8-bit word, the TMP144 can calibrate each word and keep synchronous communication throughout the process.

The steps for the SMAART Wire™ / UART communication protocol are:

1. The host sends a Start bit to start the communication process.
2. The host sends the calibration byte (55h) to allow the TMP144 to sync to the baud rate of the host.
3. The host sends a Stop bit after the calibration byte.
4. The host sends a second Start bit, followed by the command register byte and a Stop bit.
5. The host sends a third Start bit, followed by the data byte only for writes.
6. The host will send the data byte(s) if the instruction is a write command.
7. The host sends a Stop bit to finish the process.

Note

The device will break the chain and send the data byte(s) if the instruction sent in the command register is a read command.

The sequence is shown in [Figure 7-4](#).

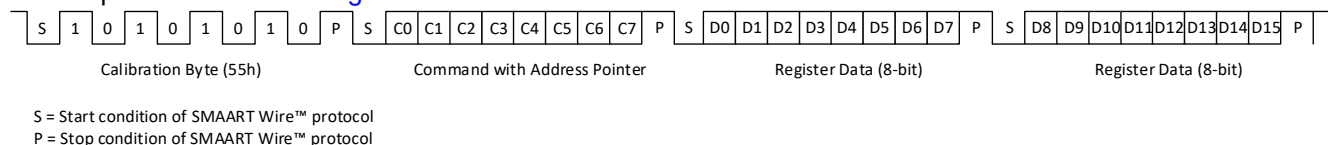

Figure 7-4. Generic Communication Write Bitstream

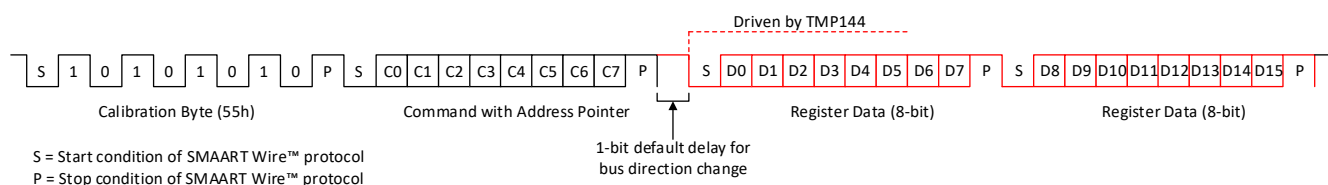

Figure 7-5. Generic Communication Read Bitstream

The command byte is decoded by the TMP144 to determine the format of the subsequent communication operation. [Table 7-2](#) lists the command register byte values.

Table 7-2. Command Byte Value

COMMAND OPERATION	COMMAND BYTE ENCODING								HEX VALUE
	C7 (MSB)	C6	C5	C4	C3	C2	C1	C0 (LSB)	
	GLBL	IN3/ID3	IN2/ID2	IN1/ID1	IN0/ID0	P1	P0	R/W	
Global software reset	1	0	1	1	0	1	0	0	B4
Global initialization	1	0	0	0	1	1	0	0	8C

Table 7-2. Command Byte Value (continued)

COMMAND OPERATION	COMMAND BYTE ENCODING								HEX VALUE
	C7 (MSB)	C6	C5	C4	C3	C2	C1	C0 (LSB)	
	GLBL	IN3/ID3	IN2/ID2	IN1/ID1	IN0/ID0	P1	P0	R/W	
Global address assignment	1	0	0	1	0	0	0	0	90
Global clear interrupt	1	0	1	0	1	0	0	1	A9
Global write	1	1	1	1	0	P1	P0	0	Based on P[1:0]
Global read	1	1	1	1	0	P1	P0	1	Based on P[1:0]
Individual write	0	ID3	ID2	ID1	ID0	P1	P0	0	Based on ID[3:0] and P[1:0]
Individual read	0	ID3	ID2	ID1	ID0	P1	P0	1	Based on ID[3:0] and P[1:0]

7.5.2 Global Software Reset

The host can initiate a global software reset command (C[7:0] = 10110100) to all TMP144 devices in the daisy-chain as shown in Figure 7-6. Upon receiving this command, the TMP144 resets all of its internal registers except for the device ID and reconnects the bus. If the bus is broken before the initiation of this command, all TMP144 devices before the broken bus point receive the command. If the host intends to initiate a global software reset across all TMP144 devices in the chain, this command must be transmitted multiple times until it echoes back to the host.

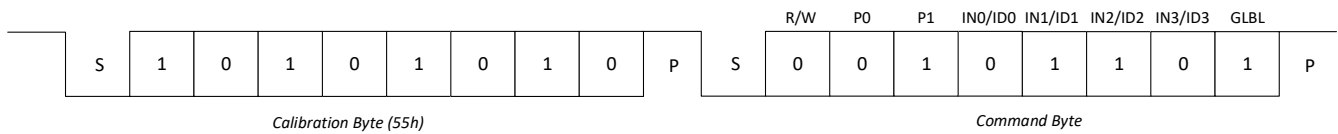

Figure 7-6. Global Software Reset Command Flow

7.5.3 Global Initialization and Address Assignment Sequence

At device power-up, every TMP144 in the daisy-chain is connected in transparent mode, as shown in Figure 7-7.

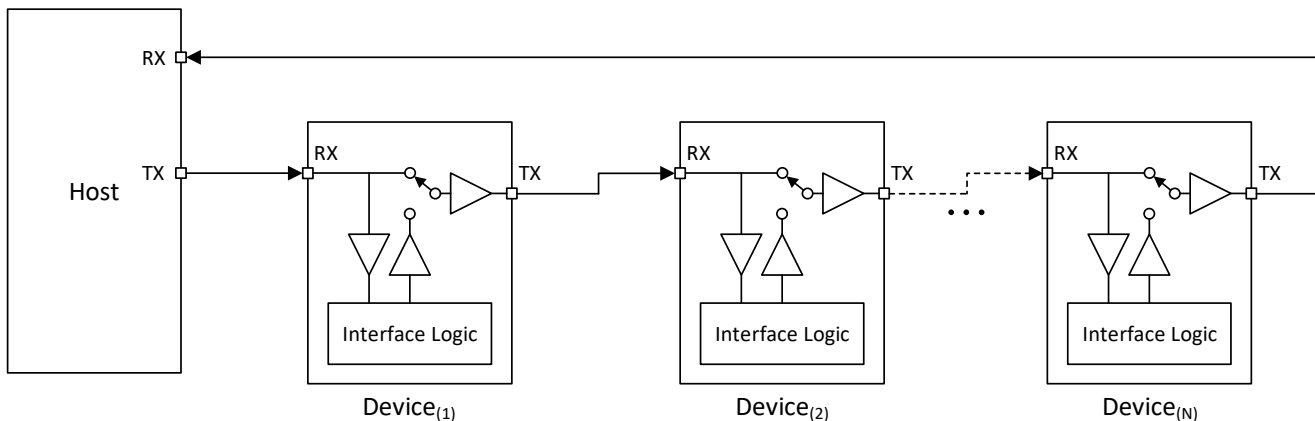

Figure 7-7. TMP144 Daisy-Chain: Bus Status at Start of Global Initialization

TMP144

SBOS891C – OCTOBER 2018 – REVISED SEPTEMBER 2023

As shown in Figure 7-8, the host must send the initialization command (C[7:0] = 1001100) for the bus to program its internal address, depending on the number of devices on the bus.

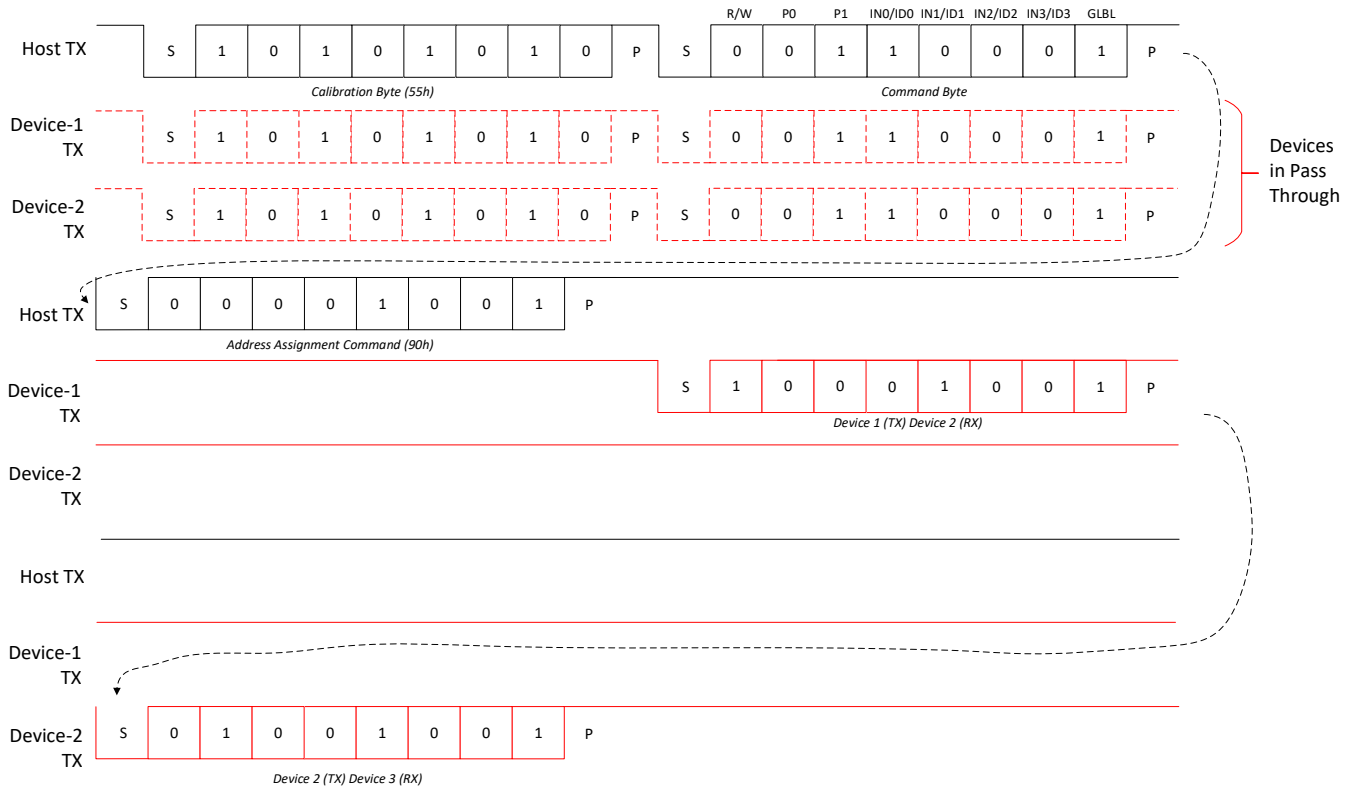

Figure 7-8. Global Initialization and Address Assignment Command Flow

Each TMP144 in the chain interprets the initialization command byte and disconnects the chain, as shown in Figure 7-9.

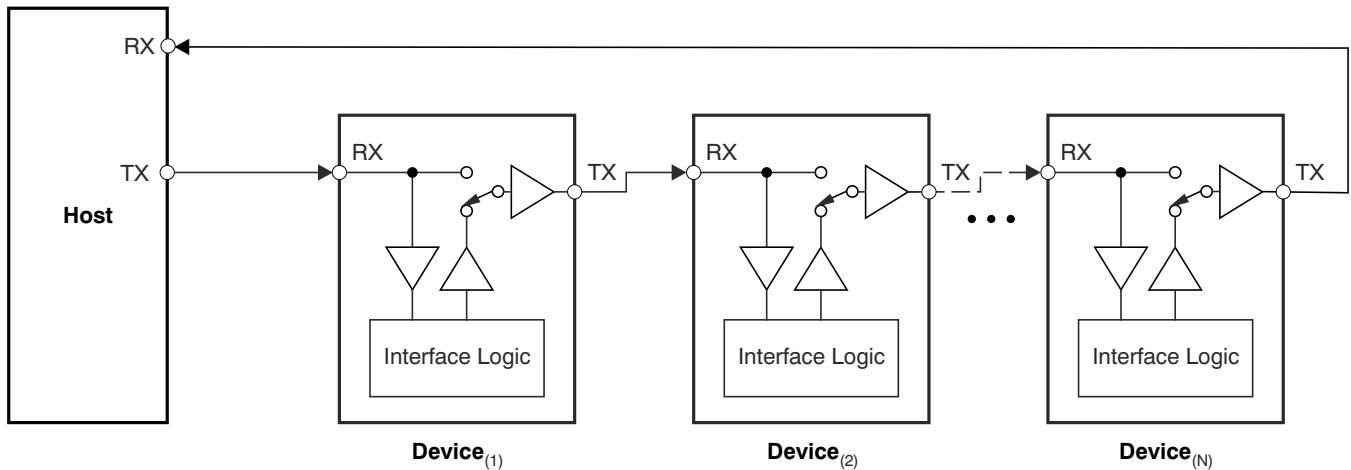

Figure 7-9. TMP144 Daisy-Chain: Bus Status at Start of Address Assignment

The host must then send the address assignment command, consisting of C[7:4] = 1001 and C[3:0] = 0000, where C[3:0] represents the address of the first device in the chain. This word is stored internally as its device ID. The first device increments the unit in the device address and then reconnects the bus, as shown in Figure 7-10. This address is then sent to the next device in the chain.

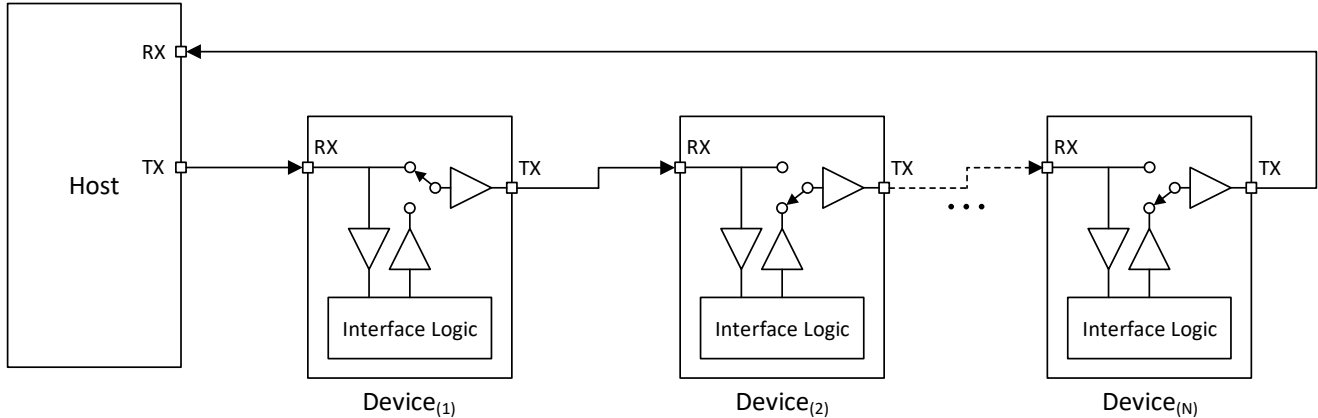

Figure 7-10. TMP144 Daisy-Chain: Bus Status After First Device Address Assignment

After all devices on the chain have received the respective addresses, the host receives the last programmed address on the chain + 1. The host can use this information to determine the total number of devices in the chain and the respective address of each device.

After the initialization sequence, every device can be addressed individually or through global commands. This global initialization sequence is a requirement and must be performed before any other communication.

7.5.4 Global Clear Interrupt

The host can initiate a global clear interrupt command ($C[7:0] = 10101001$) to all TMP144 devices in the daisy-chain as shown in Figure 7-11. Upon receiving this command, the TMP144 disables future interrupts (bit-11 in the Configuration Register is set to 0). If a TMP144 previously broke the bus connection and sent an interrupt (logic low on the bus), the device now stops holding the bus low. The device sends the baud rate calibration command and clear interrupt command to the next TMP144 in the chain, then reconnects the bus. In the case of multiple devices having active interrupts, the clear interrupt command propagates through the daisy-chain, disables all interrupts, and reconnects the bus across all devices.

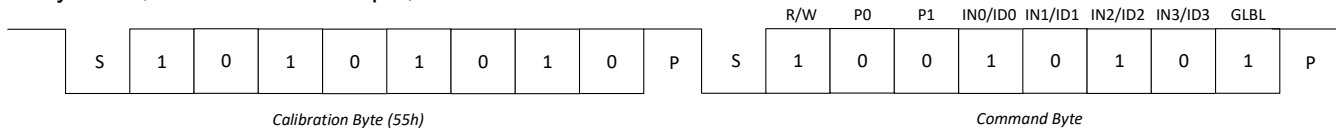

Figure 7-11. Global Clear Interrupt Command Flow

7.5.5 Global Read and Write

The host can initiate a global read or write command to all TMP144s in the daisy-chain by sending the read/write command, consisting of $C[7:3] = 11110$ and $C[2:1]$ to indicate the data register pointer $P[1:0]$, as shown in Table 7-3. A global write command is indicated by $C[0] = 0$. The host must transfer at least one more byte of data for the register, and every TMP144 in the daisy-chain updates the appropriate register as shown in Figure 7-12.

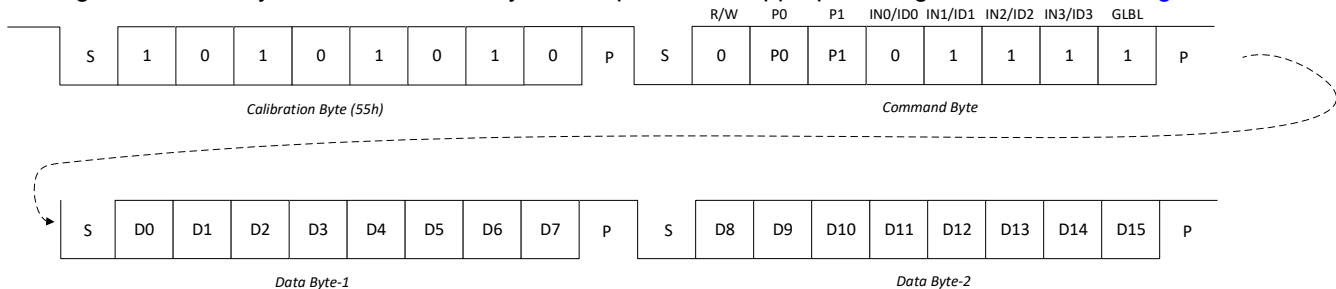

Figure 7-12. Global Write Command Flow

A global read command is indicated by $C[0] = 1$. As shown in Figure 7-13, the TMP144 with the device ID of 0000 then breaks the bus connection, transmits the data from the register indicated by bits $C[2:1]$ (corresponding to data register pointer $P[1:0]$), and then reconnects the bus. The TMP144 with the device ID of 0001 then repeats the same sequence, followed by the rest of the TMP144 devices in the daisy-chain.

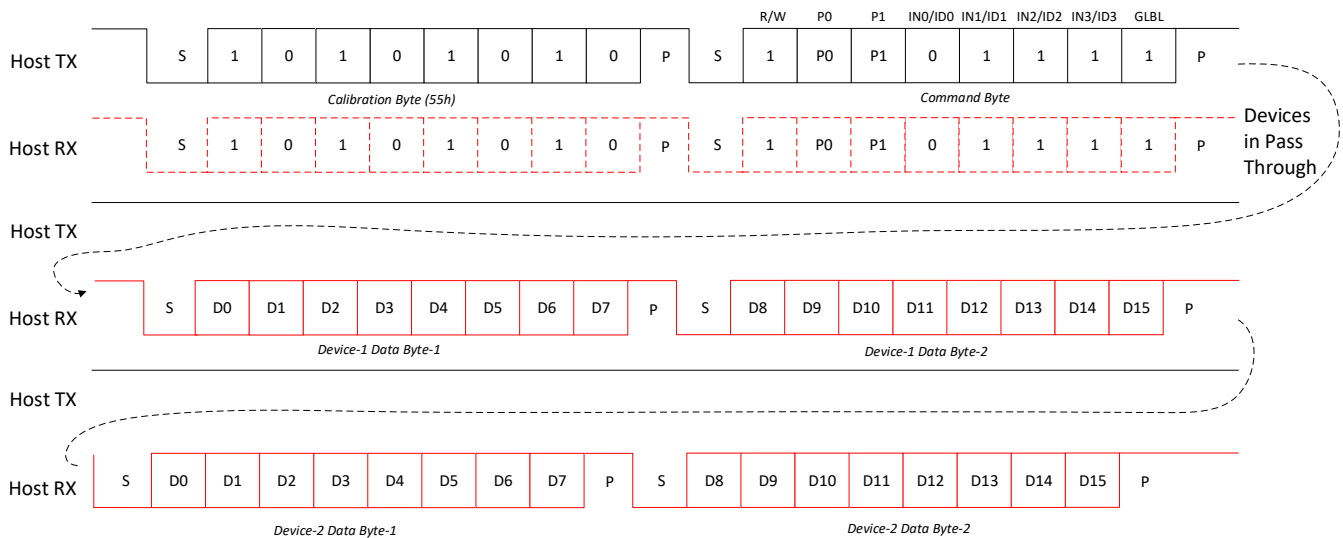

Figure 7-13. Global Read Command Flow

Table 7-3. Pointer Addresses

P1	P0	REGISTER
0	0	Temperature register (read-only)
0	1	Configuration register (read/write)
1	0	T_{LOW} register (read/write)
1	1	T_{HIGH} register (read/write)

7.5.6 Individual Read and Write

The host can initiate an individual read and write command to a particular TMP144 device in the daisy-chain by sending the read/write command. The read/write command consists of these parameters:

- $C[7] = 0$ (Individual device access)
- $C[6:3] =$ the device ID (ID[3:0])
- $C[2:1] =$ the data register pointer ($P[1:0]$); see Table 7-3
- $C[0] =$ indicates read/write control

As shown in Figure 7-14, an individual device write command is indicated by $C[0] = 0$. The host must transfer at least one more byte of data for the register indicated by bits $C[2:1]$. The TMP144 in the daisy-chain that corresponds to the device ID noted by bits $C[6:3]$ then updates the appropriate register.

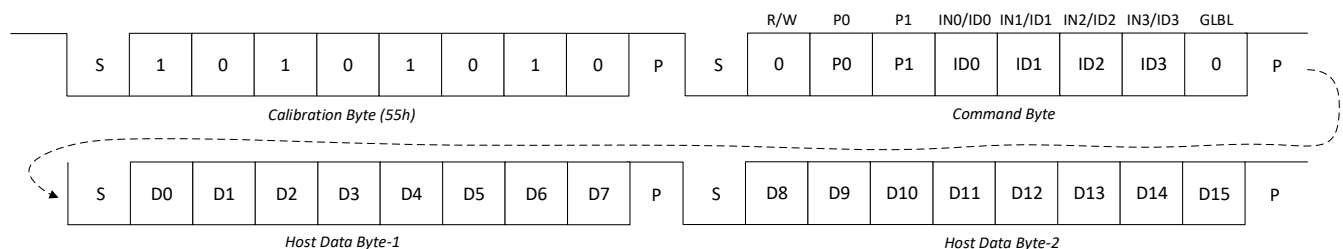

Figure 7-14. Individual Write Command Flow

As shown in Figure 7-15, an individual device read command is indicated by C[0] = 1. As shown in Figure 7-16, the TMP144 in the daisy-chain that corresponds to the device ID pointed by bits C[6:3] then breaks the bus, transmits the data from the register pointed by bits C[2:1], and reconnects the bus.

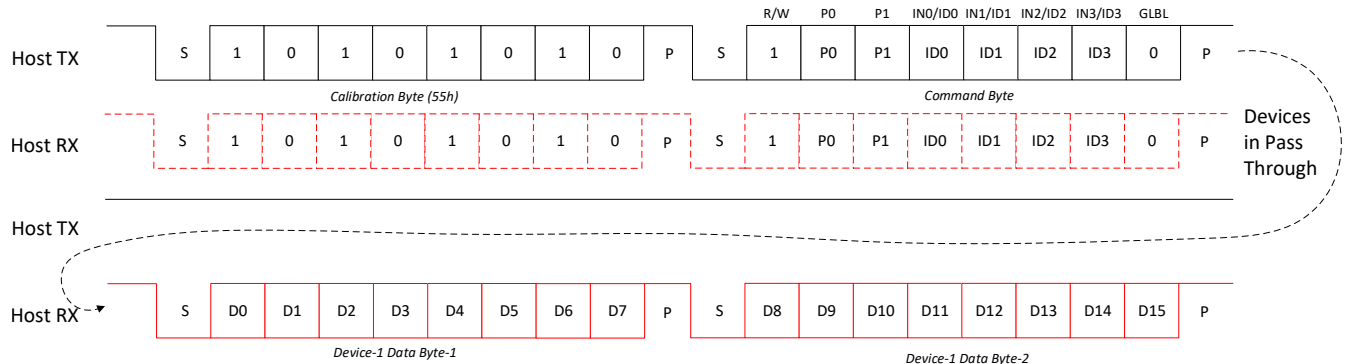

Figure 7-15. Individual Read Command Flow

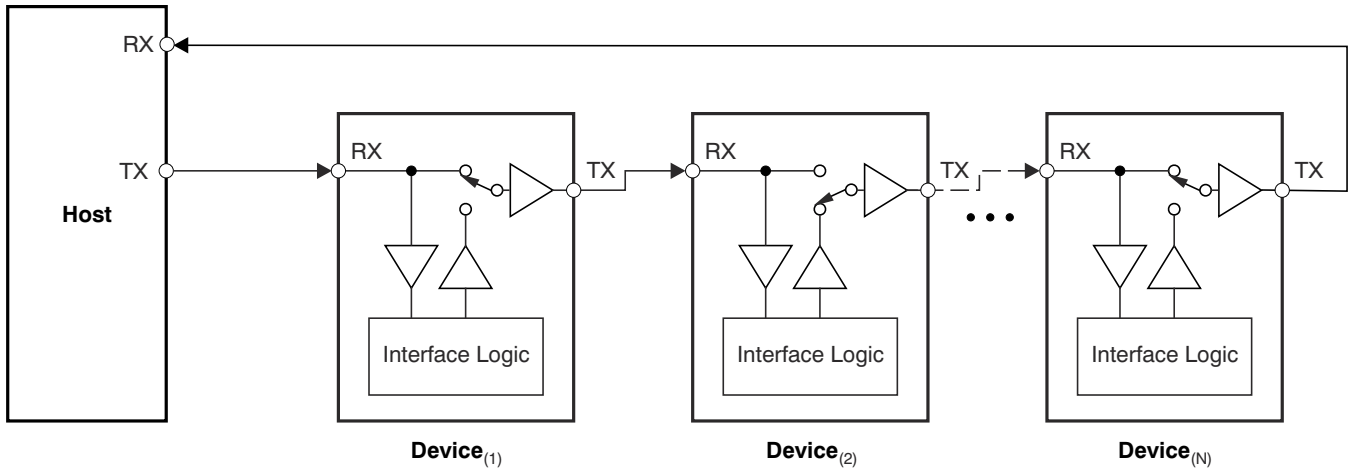

Figure 7-16. TMP144 Daisy-Chain: Bus Status During Individual Read Operation of Second Device

7.6 Register Maps

Figure 7-17 shows the internal register structure of the TMP144. Communications between the registers are transferred through the interface in LSB-first order. The 8-bit command register as shown in , is used to determine the address pointer for the register that the host device wants to access.

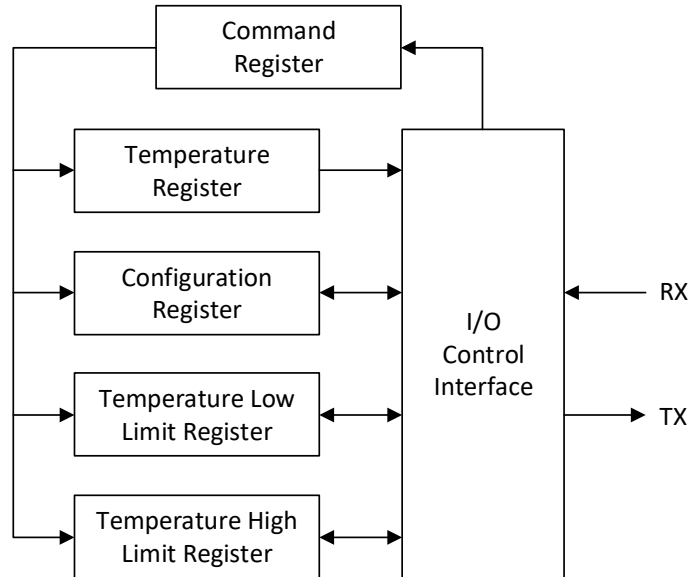

Figure 7-17. Internal Register Structure

Table 7-4. Register Map

ADDRESS POINTER P[1:0]	TYPE	RESET	ACRONYM	REGISTER NAME	SECTION
00	R	0000h	Temp_Result	Temperature result register	Go
01	R/W	0200h	Configuration	Configuration Register	Go
10	R/W	3C00h	Tlow_limit	Temperature low limit register	Go
11	R/W	F600h	Thigh_limit	Temperature high limit register	Go

Table 7-5. Register Section/Block Access Type Codes

Access Type	Code	Description
Read Type		
R	R	Read
RC	R C	Read to Clear
R-0	R -0	Read Returns 0s
Write Type		
W	W	Write
W0CP	W 0C P	W 0 to clear Requires privileged access
Reset or Default Value		
-n		Value after reset or the default value

7.6.1 Temperature Result Register (P[1:0] = 00) [reset = 0000h]

The temperature result register stores the results of the conversion in 12-bit or 13-bit format, depending on the state of the ETM bit in the configuration register. Negative numbers are represented in two's complement format. Following power-up or reset the temperature result register reads 0°C, until the first conversion is complete.

When the ETM bit is configured as '0', the temperature result register of the device is configured as 12-bit value with the least significant bit always reading '0'. One LSB for the temperature result equals 0.0625°C.

Table 7-6. Temperature Result Register (ETM = 0)

15	14	13	12	11	10	9	8	7	6	5	4	3	2	1	0
T[11:0]												EM	Reserved		
R-000h												R-0	R-0h		

Table 7-7. Temperature Result Register (ETM = 0) Field Description

Bit	Field	Type	Reset	Description
15:4	T[11:0]	R	000h	12-bit temperature result after last conversion
3	EM	R	0	Extended mode bit
2:0	Reserved	R	0h	Reserved

When the ETM bit is configured as '1', the temperature result register of the device is configured as 13-bit value. One LSB for the temperature result equals 0.0625°C.

Table 7-8. Temperature Result Register (ETM = 1)

15	14	13	12	11	10	9	8	7	6	5	4	3	2	1	0
T[12:0]													Reserved		
R-0000h													R-0h		

Table 7-9. Temperature Result Register (ETM = 1) Field Description

Bit	Field	Type	Reset	Description
15:13	T[12:0]	R	0000h	13-bit temperature result after last conversion
2:0	Reserved	R	0h	Reserved

7.6.2 Configuration Register (P[1:0] = 01) [reset = 0200h]

The configuration register is used to store bits that control the operational modes of the temperature sensors and read the status of alert flags. Read/write operations are performed LSB first.

Return to [Register Map](#).

Table 7-10. Configuration Register

15	14	13	12	11	10	9	8	7	6	5	4	3	2	1	0
INT_EN	CR[1:0]	FH	FL	LC	M[1:0]	ETM	Reserved								
R/W-0	R/W-0	R-0	R-0	R/W-0	R/W-10	R/W-0	R-00h								

Table 7-11. Configuration Register Field Description

Bit	Field	Type	Reset	Description
15	INT_EN	R/W	0	Interrupt enable bit 0 = Interrupt is disabled 1 = Interrupt is enabled
14:13	CR[1:0]	R/W	0	Conversion rate select 00 = 0.25 Hz conversion rate (default) 01 = 1 Hz conversion rate 10 = 4 Hz conversion rate 11 = 8 Hz conversion rate

Table 7-11. Configuration Register Field Description (continued)

Bit	Field	Type	Reset	Description
12	FH	R	0	Flag high temperature 0 = High temperature limit not crossed 1 = High temperature limit crossed
11	FL	R	0	Flag low temperature 0 = Low temperature limit not crossed 1 = Low temperature limit crossed
10	LC	R/W	0	Latch control bit 0 = Flag bits are cleared on read 1 = Flag bits are latched
9:8	M[1:0]	R/W	10	Conversion mode select 00 = Shutdown mode 01 = One shot conversion mode 1x = Continuous conversion mode
7	ETM	R/W	0	Extended temperature mode select 0 = Mode is disabled 1 = Mode is enabled
6:0	Reserved	R	0	Reserved

7.6.3 Temperature Low Limit Register (P[1:0] = 10) [reset = F600h]

The temperature low limit register is used to store the low temperature threshold for the device low limit flag. The default power up reset value is -10°C . The power on default value is valid only when ETM = 0. At the end of each temperature conversion, the device compares the temperature result with the temperature low limit register. If the temperature result is less than the threshold set in this register, the FL bit in the configuration register is set.

When the ETM bit in the configuration register is updated, it is strongly recommended that the user update the low limit register.

Note

When the ETM bit is set to 0, any writes to the EM bit will be ignored.

Table 7-12. Temperature Low Limit Register (ETM = 0)

15	14	13	12	11	10	9	8	7	6	5	4	3	2	1	0
L[11:0]												EM	Reserved		
R/W-F60h												R/W-0	R-0h		

Table 7-13. Temperature Low Limit Register (ETM = 0) Field Description

Bit	Field	Type	Reset	Description
15:4	L[11:0]	R/W	F60h	12-bit temperature low limit threshold
3	EM	R/W	0	Don't care when ETM = 0
2:0	Reserved	R	0h	Reserved

Table 7-14. Temperature Low Limit Register (ETM = 1)

15	14	13	12	11	10	9	8	7	6	5	4	3	2	1	0
L[12:0]													Reserved		
R/W-F600h													R-0h		

Table 7-15. Temperature Low Limit Register (ETM = 1) Field Description

Bit	Field	Type	Reset	Description
15:3	L[12:0]	R/W	F600h	13-bit temperature low limit threshold
2:0	Reserved	R	0h	Reserved

7.6.4 Temperature High Limit Register (P[1:0] = 11) [reset = 3C00h]

The temperature high limit register is used to store the high temperature threshold for the device high limit flag. The default power up reset value is +60°C. The power on default value is valid only when ETM = 0. At the end of each temperature conversion, the device compares the temperature result with the temperature high limit register. If the temperature result is greater than the threshold set in this register, the FH bit in the configuration register is set.

When the ETM bit in the configuration register is updated, it is strongly recommended that the user update the high limit register.

Note

When the ETM bit is set to 0, any writes to the EM bit will be ignored.

Table 7-16. Temperature High Limit Register (ETM = 0)

15	14	13	12	11	10	9	8	7	6	5	4	3	2	1	0
H[11:0]												EM	Reserved		
R/W-3C0h												R/W-0	R-0h		

Table 7-17. Temperature High Limit Register (ETM = 0) Field Description

Bit	Field	Type	Reset	Description
15:4	H[11:1]	R/W	3C0h	12-bit temperature high limit threshold
3	EM	R/W	0	Don't care when ETM = 0
2:0	Reserved	R	0h	Reserved

Table 7-18. Temperature High Limit Register (ETM = 1)

15	14	13	12	11	10	9	8	7	6	5	4	3	2	1	0
H[12:0]													Reserved		
R/W-3C00h													R-0h		

Table 7-19. Temperature High Limit Register (ETM = 1) Field Description

Bit	Field	Type	Reset	Description
15:3	H[12:0]	R/W	3C00h	13-bit temperature high limit threshold
2:0	Reserved	R	0h	Reserved

8 Application and Implementation

Note

Information in the following applications sections is not part of the TI component specification, and TI does not warrant its accuracy or completeness. TI's customers are responsible for determining suitability of components for their purposes, as well as validating and testing their design implementation to confirm system functionality.

8.1 Application Information

The TMP144 devices are typically used for thermal management of multiple hotspots. The MDA commands make it easy to manage multiple devices at the same time, which reduces communication time and power. The WCSP package enables the device to be placed in space-constrained designs and allows the device to have a fast thermal response.

8.2 Typical Application

Figure 8-1 shows typical connections for TMP144 devices in a daisy-chain configuration.

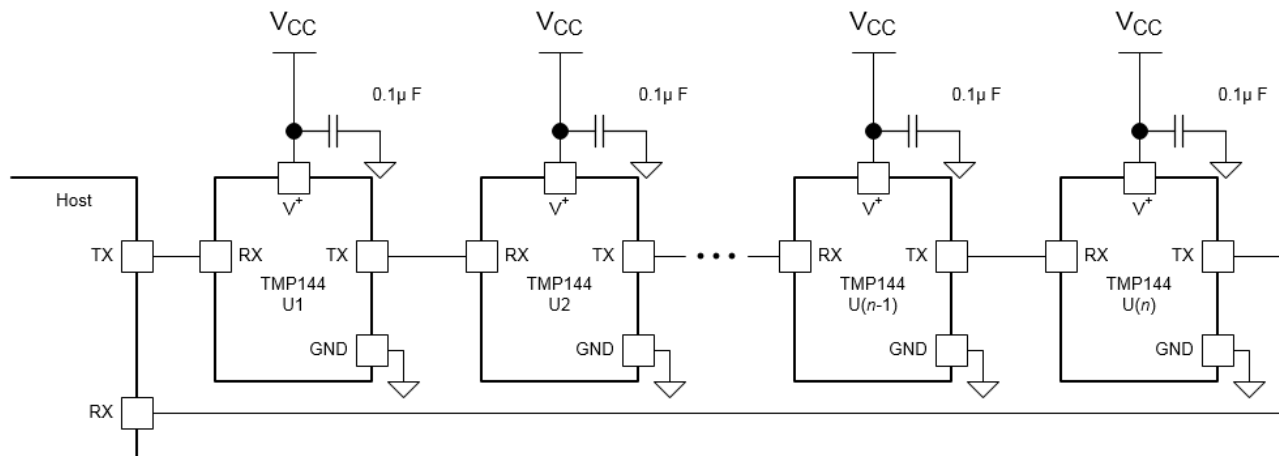

Figure 8-1. Typical Application With Multiple Devices

8.2.1 Design Requirements

Multiple devices are connected in this typical application. The key design requirements are discussed in the following sections.

8.2.2 Detailed Design Procedure

8.2.2.1 Trace Length

The maximum trace or cable length between two TMP144 devices can vary because of the effective resistance and capacitance of the type of cable used in a customer application. Design the trace or cable such that timing specifications in [Timing Diagrams](#) can be satisfied for each TMP144 device in the daisy-chain.

8.2.2.2 Voltage Drop Effect

Take into account the voltage drop that occurs along the supply and ground lines as a result of the currents of all the devices on the line. This voltage drop occurs as a result of multiple devices simultaneously consuming current through the combined resistance of the common wire, connectors, and solder contacts. Make sure that the supply on the last device does not fall below the minimum operating supply of 1.4 V.

8.2.2.3 Power Supply Noise Filtering

To reduce power supply noise, a 0.1- μF bypass capacitor is used for each TMP144 device. Depending on the environment, additional bypass capacitors (for example, 1 nF) may be required.

8.2.3 Application Curves

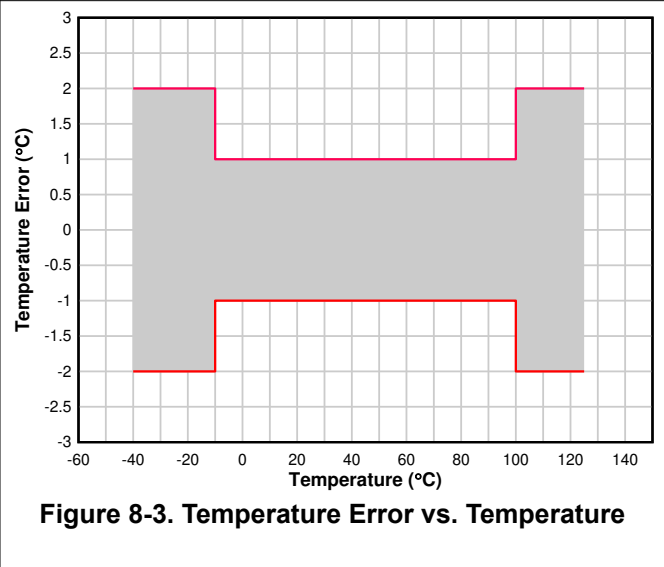
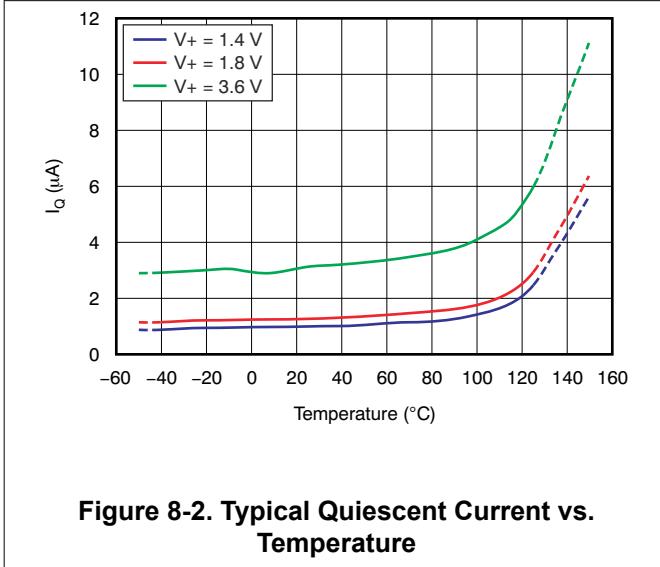

8.3 Power Supply Recommendations

The TMP144 operates on a power-supply range from 1.4 V to 3.6 V. The device is trimmed for operation at a 3.3-V supply, but the TMP144 can measure temperature accurately in the full supply range.

The TMP144 is a very low-power device and generates very low noise on the supply bus. Applying a bypass capacitor to the V+ pin of the TMP144 can further reduce any noise the TMP144 might propagate to other components. Use a C_F capacitor with a value greater than 0.1 μF as shown in Figure 8-4. Place the bypass capacitor as close to the supply and ground pins of the device as possible for best results.

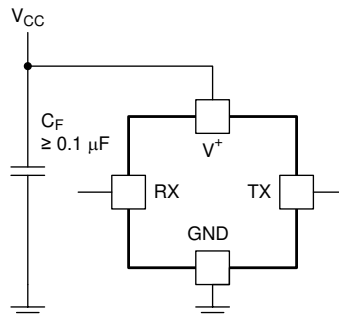

Figure 8-4. Power Supply Noise Reduction With a Bypass Capacitor

8.4 Layout

8.4.1 Layout Guidelines

Mount the TMP144 to a PCB as shown in Figure 8-5. Obtaining acceptable performance with alternate layout schemes is possible, however this layout produces good results and is intended as a guideline:

- Bypass the V+ pin to ground with a low-ESR ceramic bypass-capacitor. The typical recommended bypass capacitance is a 0.1- μF ceramic capacitor with a X5R or X7R dielectric. The optimum placement is closest to the V+ and GND pins of the device. Take care to minimize the loop area formed by the bypass-capacitor

connection, the V+ pin, and the GND pin of the IC. Alternatively, the bypass capacitor can also be grounded through a via connected to the GND plane.

- Use larger copper area pads to reduce self-heating and lower thermal resistance to the environment.
- If possible, use PCB boards with thick copper layers.
- If possible, do not use stain to protect the IC because stain can increase thermal resistance.

8.4.2 Layout Example

 VIA to power plane

 VIA to ground plane

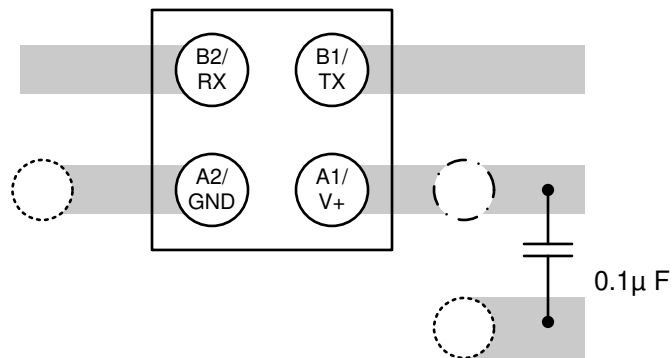

Figure 8-5. Layout Example

9 Device and Documentation Support

9.1 Device Support

9.1.1 Device Nomenclature

daisy-chain A method of propagating signals along a bus in which the devices are connected in series and the signal passed from one device to the next. The daisy-chain scheme permits assignment of device priorities based on the electrical position of the device on the bus.

9.2 Receiving Notification of Documentation Updates

To receive notification of documentation updates, navigate to the device product folder on ti.com. In the upper right corner, click on *Alert me* to register and receive a weekly digest of any product information that has changed. For change details, review the revision history included in any revised document.

9.3 Support Resources

[TI E2E™ support forums](#) are an engineer's go-to source for fast, verified answers and design help — straight from the experts. Search existing answers or ask your own question to get the quick design help you need.

Linked content is provided "AS IS" by the respective contributors. They do not constitute TI specifications and do not necessarily reflect TI's views; see TI's [Terms of Use](#).

9.4 Trademarks

SMAART Wire™ and TI E2E™ are trademarks of Texas Instruments. All trademarks are the property of their respective owners.

9.5 Electrostatic Discharge Caution



This integrated circuit can be damaged by ESD. Texas Instruments recommends that all integrated circuits be handled with appropriate precautions. Failure to observe proper handling and installation procedures can cause damage.

ESD damage can range from subtle performance degradation to complete device failure. Precision integrated circuits may be more susceptible to damage because very small parametric changes could cause the device not to meet its published specifications.

9.6 Glossary

[TI Glossary](#) This glossary lists and explains terms, acronyms, and definitions.

10 Mechanical, Packaging, and Orderable Information

The following pages include mechanical, packaging, and orderable information. This information is the most current data available for the designated devices. This data is subject to change without notice and revision of this document. For browser-based versions of this data sheet, refer to the left-hand navigation.

Table 10-1. WCSP Package C Dimensions

PACKAGE	MAX C DIMENSIONS
YFF	50 μm
YMT	20 μm
YBK	50 μm

YBK0004-C01

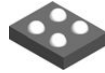

PACKAGE OUTLINE

DSBGA - 0.31 mm max height

DIE SIZE BALL GRID ARRAY

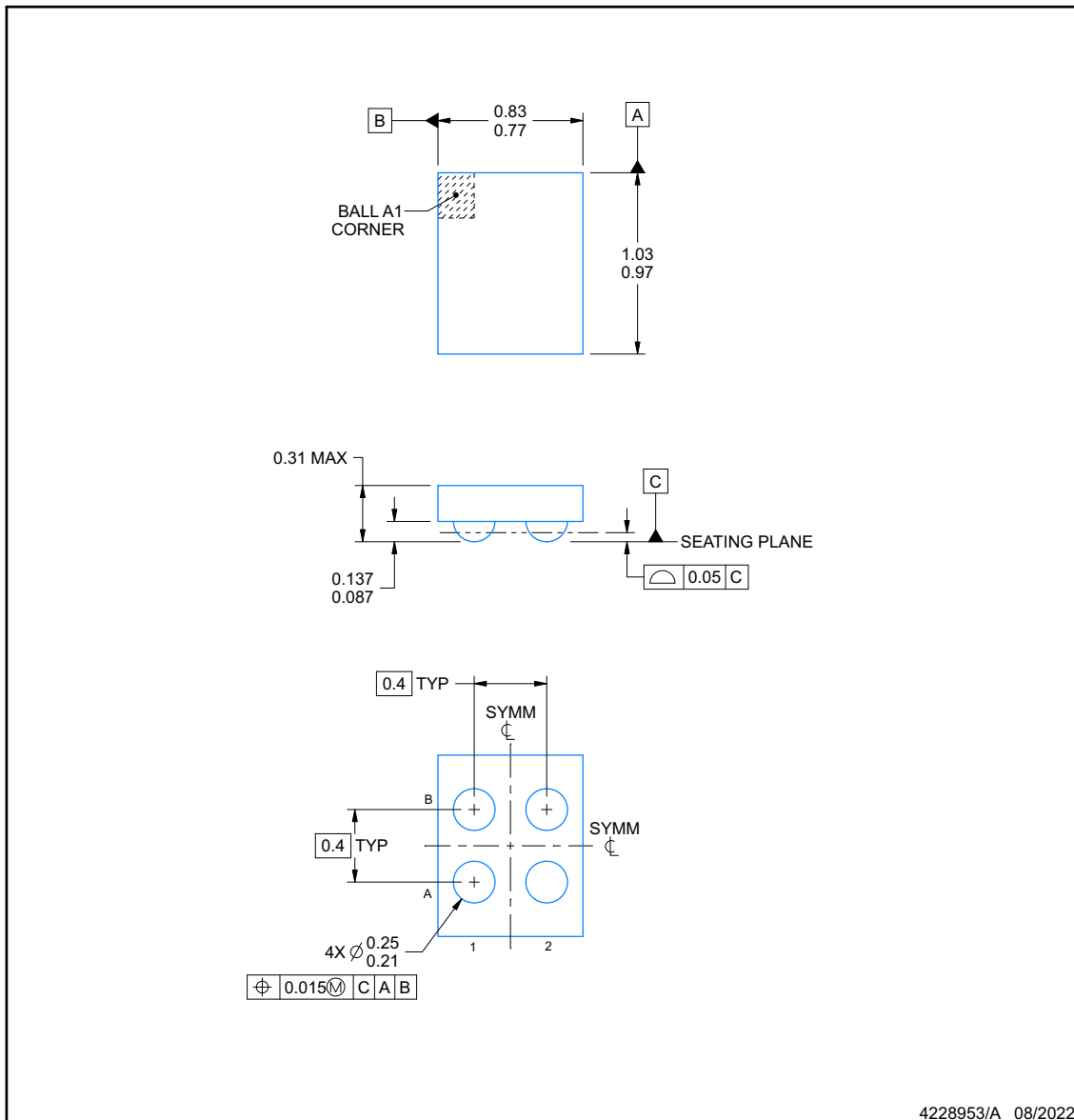

NOTES:

1. All linear dimensions are in millimeters. Any dimensions in parenthesis are for reference only. Dimensioning and tolerancing per ASME Y14.5M.
2. This drawing is subject to change without notice.

EXAMPLE BOARD LAYOUT

YBK0004-C01

DSBGA - 0.31 mm max height

DIE SIZE BALL GRID ARRAY

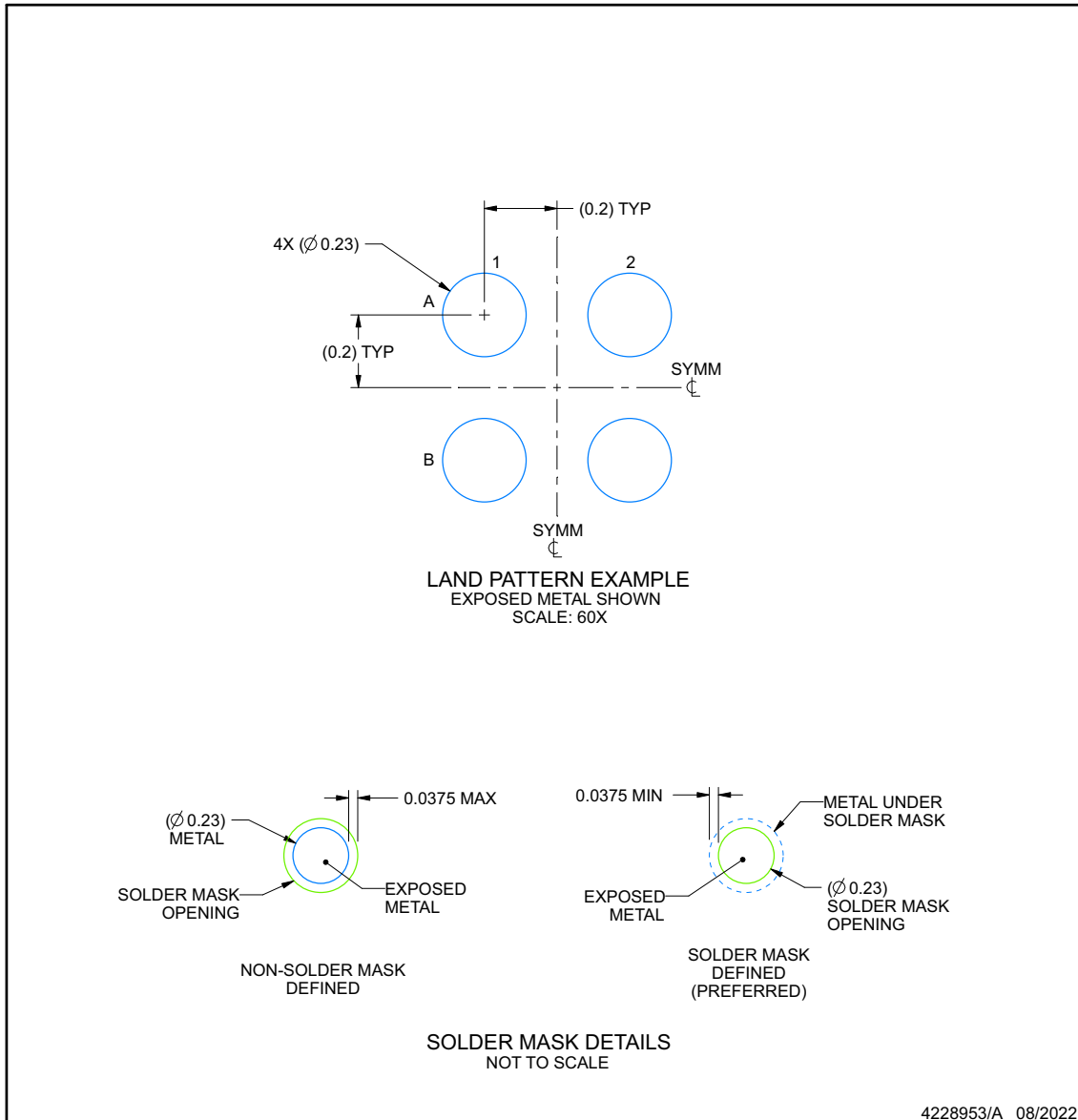

NOTES: (continued)

- Final dimensions may vary due to manufacturing tolerance considerations and also routing constraints. See Texas Instruments Literature No. SNVA009 (www.ti.com/lit/snva009).

EXAMPLE STENCIL DESIGN

YBK0004-C01

DSBGA - 0.31 mm max height

DIE SIZE BALL GRID ARRAY

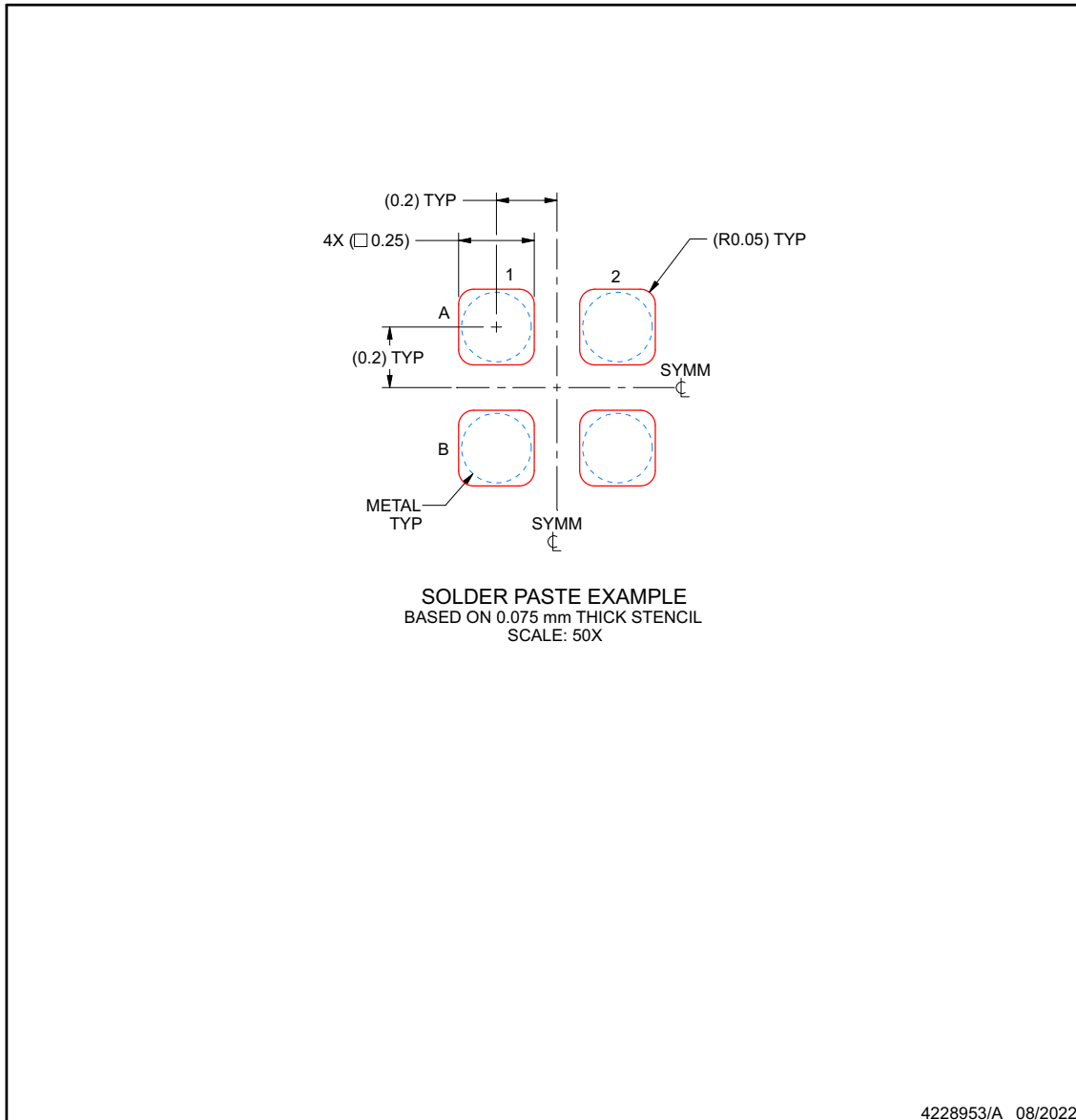

NOTES: (continued)

- 4. Laser cutting apertures with trapezoidal walls and rounded corners may offer better paste release.

PACKAGING INFORMATION

Orderable part number	Status (1)	Material type (2)	Package Pins	Package qty Carrier	RoHS (3)	Lead finish/ Ball material (4)	MSL rating/ Peak reflow (5)	Op temp (°C)	Part marking (6)
TMP144YBKR	Active	Production	DSBGA (YBK) 4	3000 LARGE T&R	Yes	SNAGCU	Level-1-260C-UNLIM	-40 to 125	NU
TMP144YBKR.B	Active	Production	DSBGA (YBK) 4	3000 LARGE T&R	Yes	SNAGCU	Level-1-260C-UNLIM	-40 to 125	NU
TMP144YFFR	Active	Production	DSBGA (YFF) 4	3000 LARGE T&R	Yes	SNAGCU	Level-1-260C-UNLIM	-40 to 125	C2
TMP144YFFR.B	Active	Production	DSBGA (YFF) 4	3000 LARGE T&R	Yes	SNAGCU	Level-1-260C-UNLIM	-40 to 125	C2
TMP144YFFT	Obsolete	Production	DSBGA (YFF) 4	-	-	Call TI	Call TI	-40 to 125	C2
TMP144YMTR	Active	Production	PICOSTAR (YMT) 4	3000 LARGE T&R	Yes	CUNIPD	Level-1-260C-UNLIM	-40 to 125	
TMP144YMTR.B	Active	Production	PICOSTAR (YMT) 4	3000 LARGE T&R	Yes	CUNIPD	Level-1-260C-UNLIM	-40 to 125	
TMP144YMTT	Obsolete	Production	PICOSTAR (YMT) 4	-	-	Call TI	Call TI	-40 to 125	

(1) **Status:** For more details on status, see our [product life cycle](#).

(2) **Material type:** When designated, preproduction parts are prototypes/experimental devices, and are not yet approved or released for full production. Testing and final process, including without limitation quality assurance, reliability performance testing, and/or process qualification, may not yet be complete, and this item is subject to further changes or possible discontinuation. If available for ordering, purchases will be subject to an additional waiver at checkout, and are intended for early internal evaluation purposes only. These items are sold without warranties of any kind.

(3) **RoHS values:** Yes, No, RoHS Exempt. See the [TI RoHS Statement](#) for additional information and value definition.

(4) **Lead finish/Ball material:** Parts may have multiple material finish options. Finish options are separated by a vertical ruled line. Lead finish/Ball material values may wrap to two lines if the finish value exceeds the maximum column width.

(5) **MSL rating/Peak reflow:** The moisture sensitivity level ratings and peak solder (reflow) temperatures. In the event that a part has multiple moisture sensitivity ratings, only the lowest level per JEDEC standards is shown. Refer to the shipping label for the actual reflow temperature that will be used to mount the part to the printed circuit board.

(6) **Part marking:** There may be an additional marking, which relates to the logo, the lot trace code information, or the environmental category of the part.

Multiple part markings will be inside parentheses. Only one part marking contained in parentheses and separated by a "-" will appear on a part. If a line is indented then it is a continuation of the previous line and the two combined represent the entire part marking for that device.

Important Information and Disclaimer: The information provided on this page represents TI's knowledge and belief as of the date that it is provided. TI bases its knowledge and belief on information provided by third parties, and makes no representation or warranty as to the accuracy of such information. Efforts are underway to better integrate information from third parties. TI has taken and continues to take reasonable steps to provide representative and accurate information but may not have conducted destructive testing or chemical analysis on incoming materials and chemicals. TI and TI suppliers consider certain information to be proprietary, and thus CAS numbers and other limited information may not be available for release.

In no event shall TI's liability arising out of such information exceed the total purchase price of the TI part(s) at issue in this document sold by TI to Customer on an annual basis.

TAPE AND REEL INFORMATION

QUADRANT ASSIGNMENTS FOR PIN 1 ORIENTATION IN TAPE

*All dimensions are nominal

Device	Package Type	Package Drawing	Pins	SPQ	Reel Diameter (mm)	Reel Width W1 (mm)	A0 (mm)	B0 (mm)	K0 (mm)	P1 (mm)	W (mm)	Pin1 Quadrant
TMP144YBKR	DSBGA	YBK	4	3000	180.0	8.4	0.86	1.06	0.44	4.0	8.0	Q1
TMP144YFFR	DSBGA	YFF	4	3000	180.0	8.4	0.86	1.06	0.69	4.0	8.0	Q1
TMP144YMTR	PICOSTAR	YMT	4	3000	180.0	8.4	0.87	1.07	0.2	2.0	8.0	Q1

TAPE AND REEL BOX DIMENSIONS



*All dimensions are nominal

Device	Package Type	Package Drawing	Pins	SPQ	Length (mm)	Width (mm)	Height (mm)
TMP144YBKR	DSBGA	YBK	4	3000	182.0	182.0	20.0
TMP144YFFR	DSBGA	YFF	4	3000	182.0	182.0	20.0
TMP144YMTR	PICOSTAR	YMT	4	3000	182.0	182.0	20.0

YMT0004



PACKAGE OUTLINE

PicoStar™ - 0.15 mm max height

PicoStar

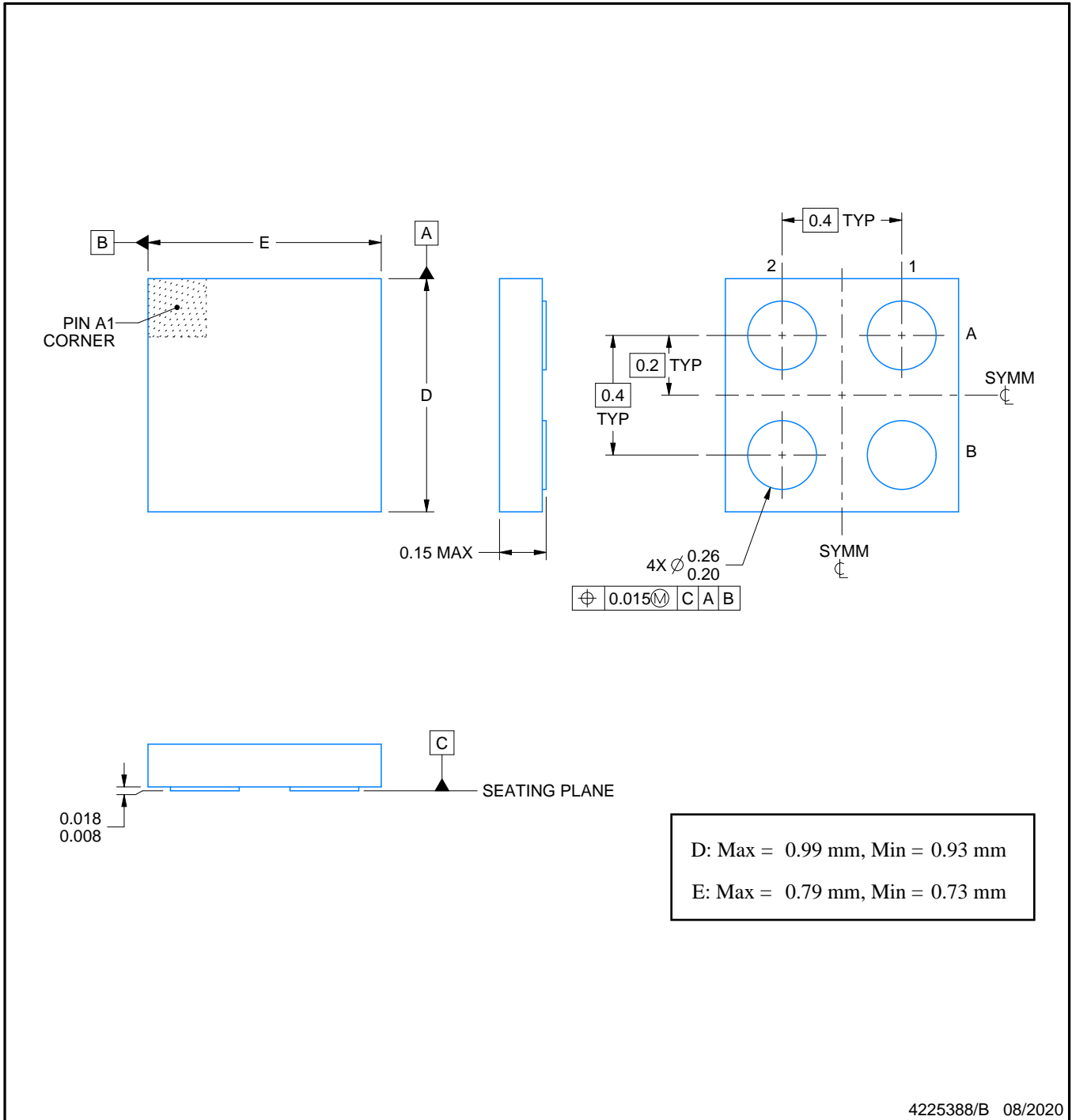

NOTES:

PicoStar is a trademark of Texas Instruments.

1. All linear dimensions are in millimeters. Any dimensions in parenthesis are for reference only. Dimensioning and tolerancing per ASME Y14.5M.
2. This drawing is subject to change without notice.

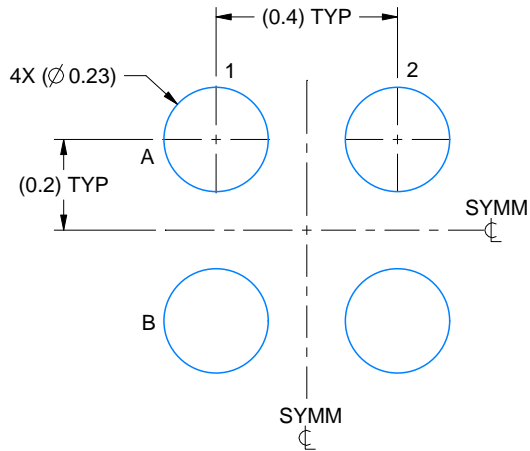

LAND PATTERN EXAMPLE
EXPOSED METAL SHOWN
SCALE:60X

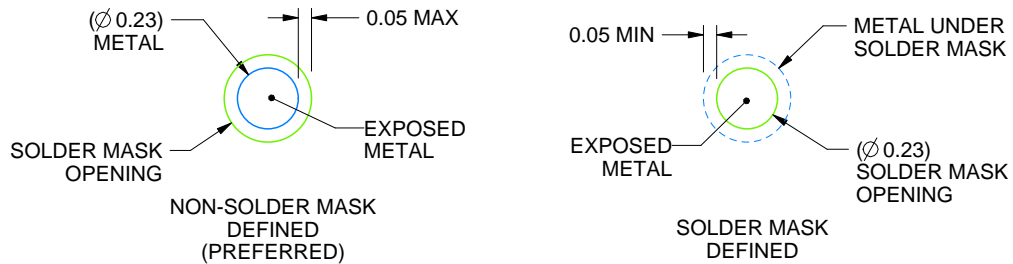

SOLDER MASK DETAILS
NOT TO SCALE

4225388/B 08/2020

NOTES: (continued)

- Final dimensions may vary due to manufacturing tolerance considerations and also routing constraints. For more information, see Texas Instruments literature number SLUA271 (www.ti.com/lit/slue271).

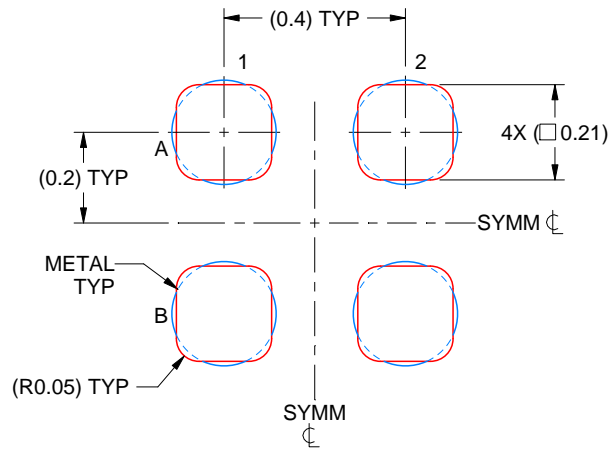

SOLDER PASTE EXAMPLE
BASED ON 0.075 mm THICK STENCIL
SCALE:60X

4225388/B 08/2020

NOTES: (continued)

4. Laser cutting apertures with trapezoidal walls and rounded corners may offer better paste release.

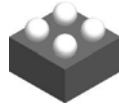

PACKAGE OUTLINE

YFF0004

DSBGA - 0.625 mm max height

DIE SIZE BALL GRID ARRAY

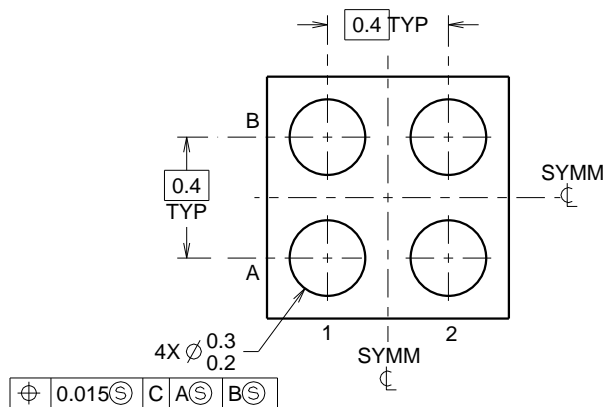
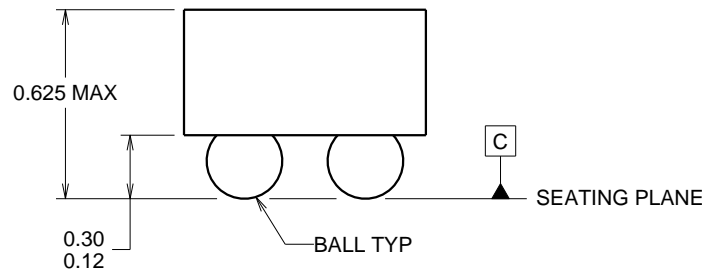
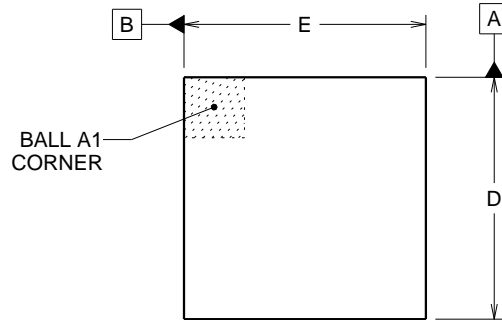

D: Max = 0.99 mm, Min = 0.93 mm
E: Max = 0.79 mm, Min = 0.73 mm

\varnothing	0.015	C	A	B
---------------	-------	---	---	---

4219460/A 02/2014

NOTES:

NanoFree Is a trademark of Texas Instruments.

1. All linear dimensions are in millimeters. Any dimensions in parenthesis are for reference only. Dimensioning and tolerancing per ASME Y14.5M.
2. This drawing is subject to change without notice.
3. NanoFree™ package configuration.

EXAMPLE BOARD LAYOUT

YFF0004

DSBGA - 0.625 mm max height

DIE SIZE BALL GRID ARRAY

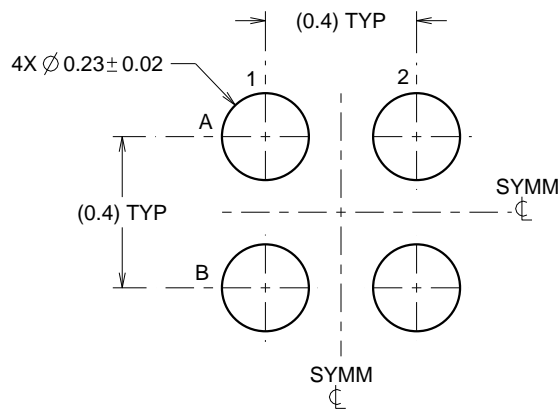

LAND PATTERN EXAMPLE
SCALE:50X

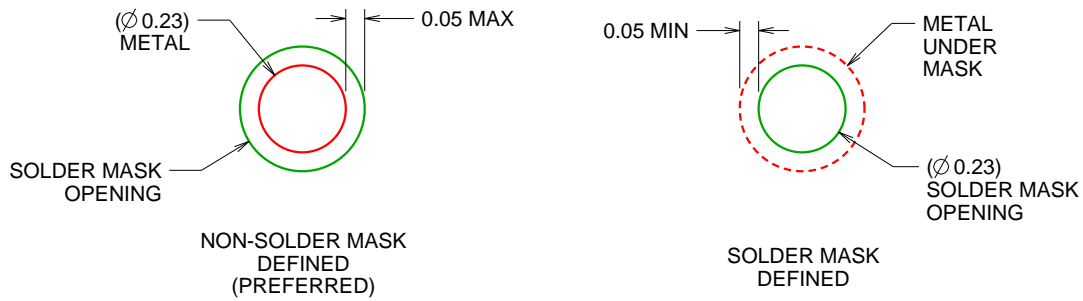

SOLDER MASK DETAILS
NOT TO SCALE

4219460/A 02/2014

NOTES: (continued)

- Final dimensions may vary due to manufacturing tolerance considerations and also routing constraints. For more information, see Texas Instruments literature number SBVA017 (www.ti.com/lit/sbva017).

EXAMPLE STENCIL DESIGN

YFF0004

DSBGA - 0.625 mm max height

DIE SIZE BALL GRID ARRAY

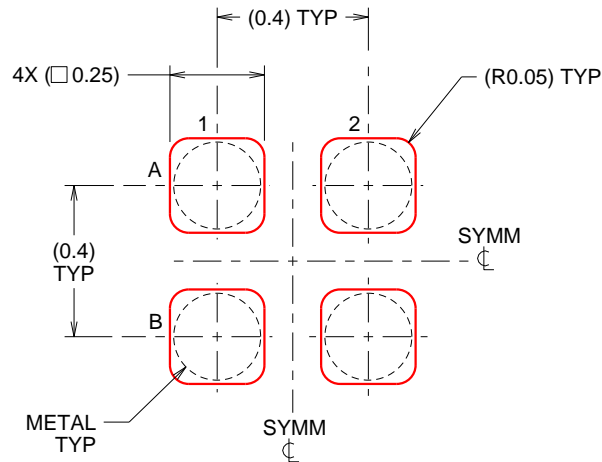

SOLDER PASTE EXAMPLE
BASED ON 0.1 mm THICK STENCIL
SCALE:50X

4219460/A 02/2014

NOTES: (continued)

5. Laser cutting apertures with trapezoidal walls and rounded corners may offer better paste release.

IMPORTANT NOTICE AND DISCLAIMER

TI PROVIDES TECHNICAL AND RELIABILITY DATA (INCLUDING DATA SHEETS), DESIGN RESOURCES (INCLUDING REFERENCE DESIGNS), APPLICATION OR OTHER DESIGN ADVICE, WEB TOOLS, SAFETY INFORMATION, AND OTHER RESOURCES "AS IS" AND WITH ALL FAULTS, AND DISCLAIMS ALL WARRANTIES, EXPRESS AND IMPLIED, INCLUDING WITHOUT LIMITATION ANY IMPLIED WARRANTIES OF MERCHANTABILITY, FITNESS FOR A PARTICULAR PURPOSE OR NON-INFRINGEMENT OF THIRD PARTY INTELLECTUAL PROPERTY RIGHTS.

These resources are intended for skilled developers designing with TI products. You are solely responsible for (1) selecting the appropriate TI products for your application, (2) designing, validating and testing your application, and (3) ensuring your application meets applicable standards, and any other safety, security, regulatory or other requirements.

These resources are subject to change without notice. TI grants you permission to use these resources only for development of an application that uses the TI products described in the resource. Other reproduction and display of these resources is prohibited. No license is granted to any other TI intellectual property right or to any third party intellectual property right. TI disclaims responsibility for, and you will fully indemnify TI and its representatives against, any claims, damages, costs, losses, and liabilities arising out of your use of these resources.

TI's products are provided subject to [TI's Terms of Sale](#) or other applicable terms available either on [ti.com](https://www.ti.com) or provided in conjunction with such TI products. TI's provision of these resources does not expand or otherwise alter TI's applicable warranties or warranty disclaimers for TI products.

TI objects to and rejects any additional or different terms you may have proposed.

Mailing Address: Texas Instruments, Post Office Box 655303, Dallas, Texas 75265

Copyright © 2025, Texas Instruments Incorporated