

# UCC23514 4-A Source, 5-A Sink, 5.0-kV<sub>RMS</sub> Opto-Compatible Single Channel Isolated Gate Drivers

## 1 Features

- 5.0-kV<sub>RMS</sub> single channel isolated gate driver with opto-compatible input
- Pin-to-pin, drop in upgrade for opto-isolated gate drivers
- 4.5-A source, 5.3-A sink, peak output current
- 12-V to 33-V output driver supply voltage
- Rail-to-rail output
- 105-ns (maximum) propagation delay
- 25-ns (maximum) part-to-part delay matching
- 35-ns (maximum) pulse width distortion
- 150-kV/μs (minimum) common-mode transient immunity (CMTI)
- Isolation barrier life > 50 Years
- 13-V reverse polarity voltage handling capability on input stage
- DWV package with 8.5 mm creepage
- Operating junction temperature, T<sub>J</sub>: –40°C to +150°C
- Safety-related certifications (Planned):
  - 7000-V<sub>PK</sub> reinforced isolation per DIN V VDE V0884-11: 2017-01
  - 5.0-kV<sub>RMS</sub> isolation for 1 minute per UL 1577
  - CQC certification per GB4943.1-2011

## 2 Applications

- Industrial motor-control drives
- Industrial power supplies, UPS
- Solar inverters
- Induction heating

## 3 Description

The UCC23514 is an Opto-compatible, single-channel, isolated gate driver for IGBTs, MOSFETs and SiC MOSFETs, with 4.5-A source and 5.3-A sink peak output current and 5.0-kV<sub>RMS</sub> reinforced isolation rating. The high supply voltage range of 33-V allows the use of bipolar supplies to effectively drive IGBTs and SiC power FETs. UCC23514 can drive both low side and high side power FETs. Key features and characteristics bring significant performance and reliability upgrades over standard opto-coupler based gate drivers while maintaining pin-to-pin compatibility in both schematic and layout design. Performance highlights include high common mode transient immunity (CMTI), low propagation delay, and small pulse width distortion.

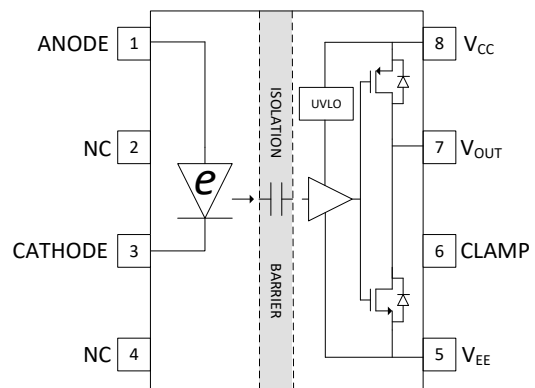
Tight process control results in small part-to-part skew. The input stage is an emulated diode (e-diode) which means long term reliability and excellent aging characteristics compared to traditional LEDs. It is offered in an 8-Pin surface mount 7.5 mm x 5.85 mm (typical) SOIC package, with creepage and clearance ≥ 8.5 mm, and a mold compound from material group I which has a comparative tracking index (CTI) > 600 V. UCC23514's high performance and reliability makes it ideal for use in all types of motor drives, solar inverters, industrial power supplies, and appliances. The higher operating temperature opens up opportunities for applications not previously able to be supported by traditional opto-couplers.

The UCC23514V option provides the gate drive output on a single terminal. For applications requiring split gate drive output, the UCC23514S version provides two separate output pins, OUTH and OUTL. The UCC23514E version suits applications requiring an UVLO referenced to a separate COM pin, which facilitates bipolar gate drive supply applications. The UCC23514M option connects the gate of the transistor to an internal clamp to prevent false turn-on caused by Miller current.

### Device Information (1)

PART NUMBER	FEATURE DESCRIPTION
UCC23514E	Emitter-referenced UVLO
UCC23514M	Miller clamp
UCC23514S	Split output
UCC23514V	Single V <sub>OUT</sub> pin

- (1) For all available packages, see the orderable addendum at the end of the data sheet.

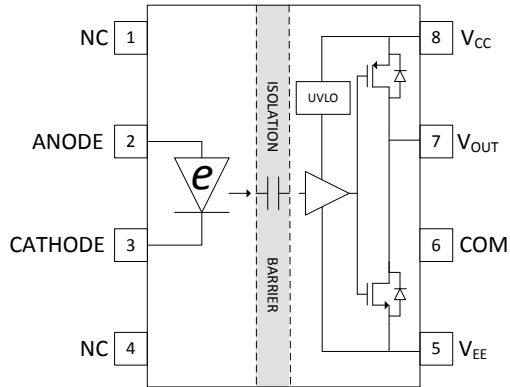


**Functional Block Diagram of UCC23514M**

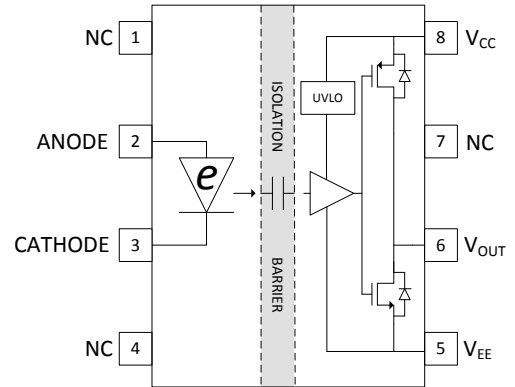


**UCC23514**

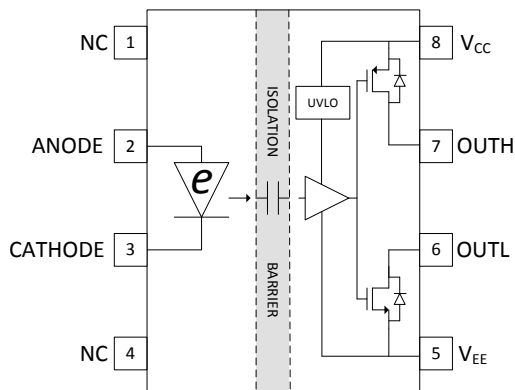
SLUSDV0A – JUNE 2020 – REVISED OCTOBER 2020



**Functional Block Diagram of UCC23514E**



**Functional Block Diagram of UCC23514V**



**Functional Block Diagram of UCC23514S**

## Table of Contents

<b>1 Features</b> .....	<b>1</b>	6.11 Insulation Characteristics .....	<b>12</b>
<b>2 Applications</b> .....	<b>1</b>	6.12 Typical Characteristics.....	<b>13</b>
<b>3 Description</b> .....	<b>1</b>	<b>7 Parameter Measurement Information</b> .....	<b>16</b>
<b>4 Revision History</b> .....	<b>3</b>	7.1 Propagation Delay, rise time and fall time.....	<b>16</b>
<b>5 Pin Configuration and Function</b> .....	<b>4</b>	7.2 I <sub>OH</sub> and I <sub>OL</sub> testing.....	<b>16</b>
Pin Functions for UCC23514E.....	4	7.3 CMTI Testing.....	<b>16</b>
Pin Functions for UCC23514M.....	4	<b>8 Detailed Description</b> .....	<b>17</b>
Pin Functions for UCC23514S.....	5	8.1 Overview.....	17
Pin Functions for UCC23514V.....	5	8.2 Functional Block Diagram.....	17
<b>6 Specifications</b> .....	<b>6</b>	8.3 Feature Description.....	19
6.1 Absolute Maximum Ratings.....	6	8.4 Device Functional Modes.....	24
6.2 ESD Ratings.....	6	<b>9 Application and Implementation</b> .....	<b>25</b>
6.3 Recommended Operating Conditions.....	6	9.1 Application Information.....	25
6.4 Thermal Information.....	6	9.2 Typical Application.....	26
6.5 Power Ratings.....	7	<b>10 Power Supply Recommendations</b> .....	<b>33</b>
6.6 Insulation Specifications.....	8	<b>11 Layout</b> .....	<b>34</b>
6.7 Safety-Related Certifications.....	9	11.1 Layout Guidelines.....	34
6.8 Safety Limiting Values.....	9	11.2 PCB Material.....	34
6.9 Electrical Characteristics.....	10	<b>12 Mechanical, Packaging, and Orderable Information</b> .....	<b>34</b>
6.10 Switching Characteristics.....	11		

## 4 Revision History

NOTE: Page numbers for previous revisions may differ from page numbers in the current version.

<b>Changes from Revision * (June 2020) to Revision A (October 2020)</b>	<b>Page</b>
• Changed marketing status from Advance Information to initial release.....	<b>3</b>

## 5 Pin Configuration and Function

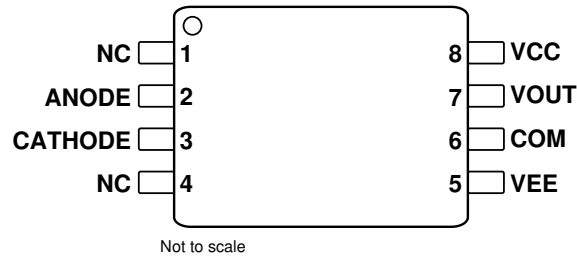


Figure 5-1. UCC23514E DWV Package 8-pin SOIC-WB Top View

### Pin Functions for UCC23514E

PIN		TYPE	DESCRIPTION
NAME	NO. UCC23514E		
NC	1	—	No Connection
ANODE	2	I	Anode
CATHODE	3	I	Cathode
NC	4	—	No Connection
V <sub>EE</sub>	5	P	Negative output supply rail
COM	6	G	IGBT Emitter connection
V <sub>OUT</sub>	7	O	Gate Drive Output
V <sub>CC</sub>	8	P	Positive output supply rail

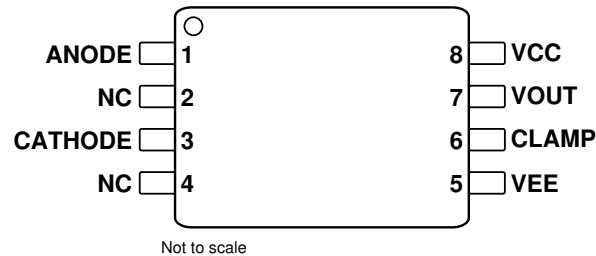
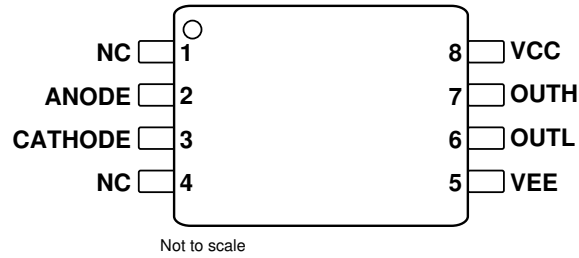


Figure 5-2. UCC23514M DWV Package 8-pin SOIC-WB Top View

### Pin Functions for UCC23514M

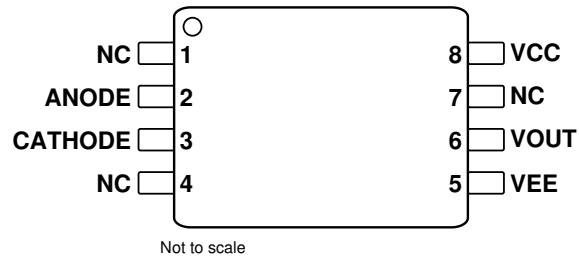
PIN		TYPE	DESCRIPTION
NAME	NO. UCC23514M		
ANODE	1	I	Anode
NC	2	—	No Connection
CATHODE	3	I	Cathode
NC	4	—	No Connection
V <sub>EE</sub>	5	P	Negative output supply rail
CLAMP	6	O	Miller Clamp Output
V <sub>OUT</sub>	7	O	Gate Drive Output
V <sub>CC</sub>	8	P	Positive output supply rail



**Figure 5-3. UCC23514S DWV Package 8-pin SOIC-WB Top View**

**Pin Functions for UCC23514S**

PIN		TYPE	DESCRIPTION
NAME	NO. UCC23514S		
NC	1	—	No Connection
ANODE	2	I	Anode
CATHODE	3	I	Cathode
NC	4	—	No Connection
V <sub>EE</sub>	5	P	Negative output supply rail
OUTL	6	O	Gate-drive Pull down
OUTH	7	O	Gate Drive Pull up
V <sub>CC</sub>	8	P	Positive output supply rail



**Figure 5-4. UCC23514V DWV Package 8-pin SOIC-WB Top View**

**Pin Functions for UCC23514V**

PIN		TYPE	DESCRIPTION
NAME	NO. UCC23514V		
NC	1	—	No Connection
ANODE	2	I	Anode
CATHODE	3	I	Cathode
NC	4	—	No Connection
V <sub>EE</sub>	5	P	Negative output supply rail
V <sub>OUT</sub>	6	O	Gate-drive output
NC	7	—	No Connection
V <sub>CC</sub>	8	P	Positive output supply rail

## 6 Specifications

### 6.1 Absolute Maximum Ratings

Over operating free air temperature range (unless otherwise noted)<sup>(1)</sup>

		MIN	MAX	UNIT
Average Input Current	$I_{F(AVG)}$	-	25	mA
Peak Transient Input Current	$I_{F(TRAN)} < 1\mu s \text{ pulse, } 300\text{pps}$		1	A
Reverse Input Voltage	$V_{R(MAX)}$		14	V
Output supply voltage	$V_{CC} - V_{EE}$	-0.3	35	V
Output signal voltage	$V_{OUT} - V_{CC}$		0.3	V
Output signal voltage	$V_{OUT} - V_{EE}$	-0.3		V
Junction temperature	$T_J$ <sup>(2)</sup>	-40	150	°C
Storage temperature	$T_{stg}$	-65	150	°C

- (1) Stresses beyond those listed under *Absolute Maximum Ratings* may cause permanent damage to the device. These are stress ratings only, which do not imply functional operation of the device at these or any other conditions beyond those indicated under *Recommended Operating Conditions*. Exposure to absolute-maximum-rated conditions for extended periods may affect device reliability.
- (2) To maintain the recommended operating conditions for  $T_J$ , see the [Section 6.4](#).

### 6.2 ESD Ratings

		VALUE	UNIT
$V_{(ESD)}$	Electrostatic discharge	Human body model (HBM), per ANSI/ESDA/JEDEC JS-001 <sup>(1)</sup>	V
		Charged device model (CDM), per JEDEC specification JESD22-C101 <sup>(2)</sup>	
		±4000	
		±1000	

- (1) JEDEC document JEP155 states that 500-V HBM allows safe manufacturing with a standard ESD control process.
- (2) JEDEC document JEP157 states that 250-V CDM allows safe manufacturing with a standard ESD control process.

### 6.3 Recommended Operating Conditions

Over operating free-air temperature range (unless otherwise noted)

		MIN	NOM	MAX	UNIT
$V_{CC}$	Output Supply Voltage( $V_{CC} - V_{EE}$ )	14		33	V
$I_F$ (ON)	Input Diode Forward Current (Diode "ON")	7		16	mA
$V_F$ (OFF)	Anode voltage - Cathode voltage (Diode "OFF")	-13		0.9	V
$T_J$	Junction temperature	-40		150	°C
$T_A$	Ambient temperature	-40		125	°C

### 6.4 Thermal Information

THERMAL METRIC <sup>(1)</sup>		UCC23514E, UCC23514M, UCC23514S, UCC23514V	
		DWV (SOIC)	
		8 PINS	
			UNIT
$R_{\theta JA}$	Junction-to-ambient thermal resistance	108.5	°C/W
$R_{\theta JC(top)}$	Junction-to-case (top) thermal resistance	52.0	°C/W
$R_{\theta JB}$	Junction-to-board thermal resistance	58.6	°C/W
$\Psi_{JT}$	Junction-to-top characterization parameter	32.7	°C/W
$\Psi_{JB}$	Junction-to-board characterization parameter	56.6	°C/W

- (1) For more information about traditional and new thermal metrics, see the <http://www.ti.com/lit/SPRA953> application report.

## 6.5 Power Ratings

PARAMETER		TEST CONDITIONS	MIN	TYP	MAX	UNIT
$P_D$	Maximum power dissipation on input and output <sup>(1)</sup>	$V_{CC} = 20\text{ V}$ , $I_F = 10\text{ mA}$ 10-kHz, 50% duty cycle, square wave, 180-nF load, $T_A = 25^\circ\text{C}$			750	mW
$P_{D1}$	Maximum input power dissipation <sup>(2)</sup>				10	mW
$P_{D2}$	Maximum output power dissipation				740	mW

- (1) Derate at 6 mW/°C beyond 25°C ambient temperature  
 (2) Recommended maximum  $P_{D1} = 40\text{ mW}$ . Absolute maximum  $P_{D1} = 55\text{ mW}$

## 6.6 Insulation Specifications

PARAMETER		TEST CONDITIONS	VALUE	UNIT
CLR	External clearance <sup>(1)</sup>	Shortest pin-to-pin distance through air	> 8.5	mm
CPG	External creepage <sup>(1)</sup>	Shortest pin-to-pin distance across the package surface	> 8.5	mm
DTI	Distance through the insulation	Minimum internal gap (internal clearance)	> 17	µm
CTI	Comparative tracking index	DIN EN 60112 (VDE 0303-11); IEC 60112	> 600	V
	Material group	According to IEC 60664-1	I	
	Overvoltage category per IEC 60664-1	Rated mains voltage ≤ 600 V <sub>RMS</sub>	I-IV	
		Rated mains voltage ≤ 1000 V <sub>RMS</sub>	I-III	
<b>DIN V VDE V 0884-11:2017-01<sup>(2)</sup></b>				
V <sub>IORM</sub>	Maximum repetitive peak isolation voltage	AC voltage (bipolar)	2121	V <sub>PK</sub>
V <sub>IOWM</sub>	Maximum working isolation voltage	AC voltage (sine wave); time dependent dielectric breakdown (TDDB) test;	1500	V <sub>RMS</sub>
		DC Voltage	2121	V <sub>DC</sub>
V <sub>IOTM</sub>	Maximum transient isolation voltage	V <sub>TEST</sub> = V <sub>IOTM</sub> , t = 60 s (qualification); V <sub>TEST</sub> = 1.2 × V <sub>IOTM</sub> , t = 1 s (100% production)	7000	V <sub>PK</sub>
V <sub>IOSM</sub>	Maximum surge isolation voltage <sup>(3)</sup>	Test method per IEC 62368-1, 1.2/50 µs waveform, V <sub>TEST</sub> = 1.6 × V <sub>IOSM</sub> (qualification)	8000	V <sub>PK</sub>
Q <sub>pd</sub>	Apparent charge <sup>(4)</sup>	Method a, After I/O safety test subgroup 2/3, V <sub>ini</sub> = V <sub>IOTM</sub> , t <sub>ini</sub> = 60 s; V <sub>pd(m)</sub> = 1.2 × V <sub>IORM</sub> , t <sub>m</sub> = 10 s	≤ 5	pC
		Method a, After environmental tests subgroup 1, V <sub>ini</sub> = V <sub>IOTM</sub> , t <sub>ini</sub> = 60 s; V <sub>pd(m)</sub> = 1.6 × V <sub>IORM</sub> = 2400 V <sub>PK</sub> , t <sub>m</sub> = 10 s	≤ 5	
		Method b1; At routine test (100% production) and preconditioning (type test) V <sub>ini</sub> = 1.2 × V <sub>IOTM</sub> ; t <sub>ini</sub> = 1 s; V <sub>pd(m)</sub> = 1.875 × V <sub>IORM</sub> = 2813 V <sub>PK</sub> , t <sub>m</sub> = 1 s	≤ 5	
C <sub>IO</sub>	Barrier capacitance, input to output <sup>(5)</sup>	V <sub>IO</sub> = 0.4 sin (2πft), f = 1 MHz	0.5	pF
R <sub>IO</sub>	Isolation resistance, input to output <sup>(5)</sup>	V <sub>IO</sub> = 500 V at T <sub>A</sub> = 25°C	> 10 <sup>12</sup>	Ω
		V <sub>IO</sub> = 500 V at 100°C ≤ T <sub>A</sub> ≤ 125°C	> 10 <sup>11</sup>	
		V <sub>IO</sub> = 500 V at T <sub>S</sub> = 150°C	> 10 <sup>9</sup>	
	Pollution degree		2	
	Climatic category		40/125/21	
<b>UL 1577</b>				
V <sub>ISO</sub>	Withstand isolation voltage	V <sub>TEST</sub> = V <sub>ISO</sub> = 5000 V <sub>RMS</sub> , t = 60 s. (qualification), V <sub>TEST</sub> = 1.2 × V <sub>ISO</sub> = 6840 V <sub>RMS</sub> , t = 1 s (100% production)	5000	V <sub>RMS</sub>

- (1) Creepage and clearance requirements should be applied according to the specific equipment isolation standards of an application. Care should be taken to maintain the creepage and clearance distance of a board design to ensure that the mounting pads of the isolator on the printed-circuit board do not reduce this distance. Creepage and clearance on a printed-circuit board become equal in certain cases. Techniques such as inserting grooves, ribs, or both on a printed circuit board are used to help increase these specifications.
- (2) This coupler is suitable for safe electrical insulation only within the safety ratings. Compliance with the safety ratings shall be ensured by means of suitable protective circuits.
- (3) Testing is carried out in air or oil to determine the intrinsic surge immunity of the isolation barrier.
- (4) Apparent charge is electrical discharge caused by a partial discharge (pd).
- (5) All pins on each side of the barrier tied together creating a two-pin device.

## 6.7 Safety-Related Certifications

VDE	UL	CQC
Plan to certify according to DIN V VDE V 0884-11: 2017-01	Plan to certify according to UL 1577 Component Recognition Program	Plan to certify according to GB4943.1-2011
Reinforced insulation Maximum transient isolation voltage, 7000 V <sub>PK</sub> ; Maximum repetitive peak isolation voltage, 2121 V <sub>PK</sub> Maximum surge isolation voltage, 8000 V <sub>PK</sub>	Single protection, 5000 V <sub>RMS</sub>	Reinforced insulation, Altitude ≤ 5000 m, Tropical Climate
Certificate planned	Certificate planned	Certificate planned

## 6.8 Safety Limiting Values

PARAMETER		TEST CONDITIONS	MIN	TYP	MAX	UNIT
I <sub>S</sub>	Safety input, output, or supply current	R <sub>qJA</sub> = 126°C/W, V <sub>I</sub> = 15 V, T <sub>J</sub> = 150°C, T <sub>A</sub> = 25°C			50	mA
		R <sub>qJA</sub> = 126°C/W, V <sub>I</sub> = 30 V, T <sub>J</sub> = 150°C, T <sub>A</sub> = 25°C			25	
P <sub>S</sub>	Safety input, output, or total power	R <sub>qJA</sub> = 126°C/W, T <sub>J</sub> = 150°C, T <sub>A</sub> = 25°C			750	mW
T <sub>S</sub>	Maximum safety temperature <sup>(1)</sup>				150	°C

- (1) The maximum safety temperature, T<sub>S</sub>, has the same value as the maximum junction temperature, T<sub>J</sub>, specified for the device. The I<sub>S</sub> and P<sub>S</sub> parameters represent the safety current and safety power respectively. The maximum limits of I<sub>S</sub> and P<sub>S</sub> should not be exceeded. These limits vary with the ambient temperature, T<sub>A</sub>. The junction-to-air thermal resistance, R<sub>qJA</sub>, in the Thermal Information table is that of a device installed on a high-K test board for leaded surface-mount packages. Use these equations to calculate the value for each parameter: T<sub>J</sub> = T<sub>A</sub> + R<sub>qJA</sub> · P, where P is the power dissipated in the device. T<sub>J(max)</sub> = T<sub>S</sub> = T<sub>A</sub> + R<sub>qJA</sub> · P<sub>S</sub>, where T<sub>J(max)</sub> is the maximum allowed junction temperature. P<sub>S</sub> = I<sub>S</sub> · V<sub>I</sub>, where V<sub>I</sub> is the maximum supply voltage.

## 6.9 Electrical Characteristics

Unless otherwise noted, all typical values are at  $T_A = 25^\circ\text{C}$ ,  $V_{CC}-V_{EE} = 15\text{V}$ ,  $V_{EE} = \text{GND}$ . All min and max specifications are at recommended operating conditions ( $T_J = -40^\circ\text{C}$  to  $150^\circ\text{C}$ ,  $I_{F(\text{on})} = 7\text{ mA}$  to  $16\text{ mA}$ ,  $V_{EE} = \text{GND}$ ,  $V_{CC} = 15\text{ V}$  to  $30\text{ V}$ ,  $V_{F(\text{off})} = -5\text{V}$  to  $0.8\text{V}$ )

PARAMETER		TEST CONDITIONS	MIN	TYP	MAX	UNIT
<b>INPUT</b>						
$I_{\text{FLH}}$	Input Forward Threshold Current Low to High	$V_{\text{OUT}} > 5\text{ V}$ , $C_g = 1\text{ nF}$	1.5	2.8	4	mA
$V_F$	Input Forward Voltage	$I_F = 10\text{ mA}$	1.8	2.1	2.4	V
$V_{F\_HL}$	Threshold Input Voltage High to Low	$V < 5\text{ V}$ , $C_g = 1\text{ nF}$	0.9			V
$\Delta V_F/\Delta T$	Temp Coefficient of Input Forward Voltage	$I_F = 10\text{ mA}$		1	1.35	mV/°C
$V_R$	Input Reverse Breakdown Voltage	$I_R = 10\text{ uA}$	15			V
$C_{\text{IN}}$	Input Capacitance	$F = 0.5\text{ MHz}$		15		pF
<b>OUTPUT</b>						
$I_{\text{OH}}$	High Level Peak Output Current	$I_F = 10\text{ mA}$ , $V_{CC} = 15\text{V}$ , $C_{\text{LOAD}} = 0.18\text{ uF}$ , $C_{\text{VDD}} = 10\text{ uF}$ , pulse width $< 10\text{ us}$	3	4.5		A
$I_{\text{OL}}$	Low Level Peak Output Current	$V_F = 0\text{ V}$ , $V_{CC} = 15\text{V}$ , $C_{\text{LOAD}} = 0.18\text{ uF}$ , $C_{\text{VDD}} = 10\text{ uF}$ , pulse width $< 10\text{ us}$	3.5	5.3		A
$V_{\text{OH}}$	High Level Output Voltage	$I_F = 10\text{ mA}$ , $I_O = -20\text{ mA}$ (with respect to $V_{CC}$ )	0.07	0.18	0.36	V
		$I_F = 10\text{ mA}$ , $I_O = 0\text{ mA}$		VCC		V
$V_{\text{OL}}$	Low Level Output Voltage	$V_F = 0\text{ V}$ , $I_O = 20\text{ mA}$			25	mV
$I_{\text{CC\_H}}$	Output Supply Current (Diode On)	$I_F = 10\text{ mA}$ , $I_O = 0\text{ mA}$			2.2	mA
$I_{\text{CC\_L}}$	Output Supply Current (Diode Off)	$V_F = 0\text{ V}$ , $I_O = 0\text{ mA}$			2	mA
<b>INTERNAL MILLER CLAMP</b>						
$V_{\text{CLMP\_TH}}$	Miller Clamp Threshold Voltage	$\text{CLAMP} - V_{EE}$		2.1	2.3	V
$I_{\text{CLMP}}$	Miller Clamp current	$\text{CLAMP} = 3.5\text{V}$ above $V_{EE}$		1.6		A
<b>UNDER VOLTAGE LOCKOUT</b>						
$UVLO_R$	Under Voltage Lockout $V_{CC}$ , rising	<b>UCC23514M, UCC23514S, and UCC23514V:</b> $V_{CC}$ to $V_{EE}$ , $I_F = 10\text{ mA}$	11	12.5	13.5	V
		<b>UCC23514E:</b> $V_{CC}$ to COM, $I_F = 10\text{ mA}$				
$UVLO_F$	Under Voltage Lockout $V_{CC}$ , falling	<b>UCC23514M, UCC23514S, and UCC23514V:</b> $V_{CC}$ to $V_{EE}$ , $I_F = 10\text{ mA}$	10	11.5	12.5	V
		<b>UCC23514E:</b> $V_{CC}$ to COM, $I_F = 10\text{ mA}$				
$UVLO_{\text{HYS}}$	UVLO Hysteresis			1.0		V

## 6.10 Switching Characteristics

Unless otherwise noted, all typical values are at  $T_A = 25^\circ\text{C}$ ,  $V_{CC}-V_{EE} = 30\text{ V}$ ,  $V_{EE} = \text{GND}$ . All min and max specifications are at recommended operating conditions ( $T_J = -40$  to  $150^\circ\text{C}$ ,  $I_{F(\text{ON})} = 7\text{ mA}$  to  $16\text{ mA}$ ,  $V_{EE} = \text{GND}$ ,  $V_{CC} = 15\text{ V}$  to  $30\text{ V}$ ,  $V_{F(\text{OFF})} = -5\text{ V}$  to  $0.8\text{ V}$ )

PARAMETER		TEST CONDITIONS	MIN	TYP	MAX	UNIT
$t_r$	Output-signal Rise Time	$C_g = 1\text{ nF}$ $F_{\text{SW}} = 20\text{ kHz}$ , (50% Duty Cycle) $V_{CC} = 15\text{ V}$			28	ns
$t_f$	Output-signal Fall Time				25	ns
$t_{\text{PLH}}$	Propagation Delay, Low to High		70	105	ns	
$t_{\text{PHL}}$	Propagation Delay, High to Low		70	105	ns	
$t_{\text{PWD}}$	Pulse Width Distortion $ t_{\text{PHL}} - t_{\text{PLH}} $				35	ns
$t_{\text{sk(pp)}}$	Part-to-Part Skew in Propagation Delay Between any Two Parts <sup>(1)</sup>	$C_g = 1\text{ nF}$ $F_{\text{SW}} = 20\text{ kHz}$ , (50% Duty Cycle) $V_{CC} = 15\text{ V}$ , $I_F = 10\text{ mA}$			25	ns
$t_{\text{UVLO\_rec}}$	UVLO Recovery Delay	$V_{CC}$ Rising from $0\text{ V}$ to $15\text{ V}$		20	30	$\mu\text{s}$
$\text{CMT}_{\text{H}}$	Common-mode Transient Immunity (Output High)	$I_F = 10\text{ mA}$ , $V_{\text{CM}} = 1500\text{ V}$ , $V_{CC} = 30\text{ V}$ , $T_A = 25^\circ\text{C}$	150			$\text{kV}/\mu\text{s}$
$\text{CMT}_{\text{L}}$	Common-mode Transient Immunity (Output Low)	$V_F = 0\text{ V}$ , $V_{\text{CM}} = 1500\text{ V}$ , $V_{CC} = 30\text{ V}$ , $T_A = 25^\circ\text{C}$	150			$\text{kV}/\mu\text{s}$

- (1)  $t_{\text{sk(pp)}}$  is the magnitude of the difference in propagation delay times between the output of different devices switching in the same direction while operating at identical supply voltages, temperature, input signals and loads ensured by characterization.

## 6.11 Insulation Characteristics

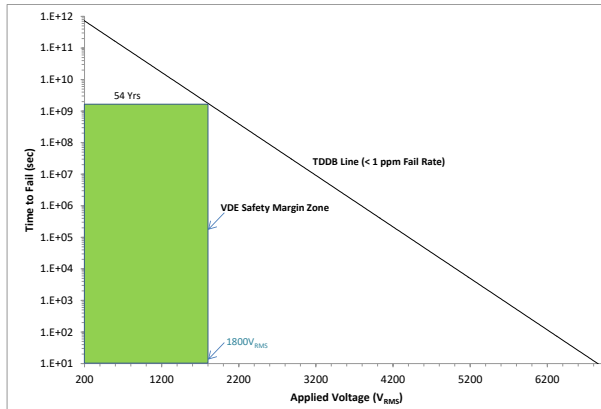
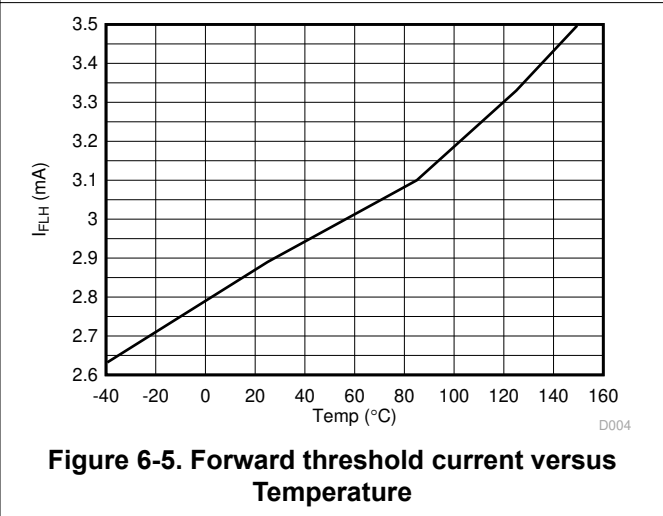
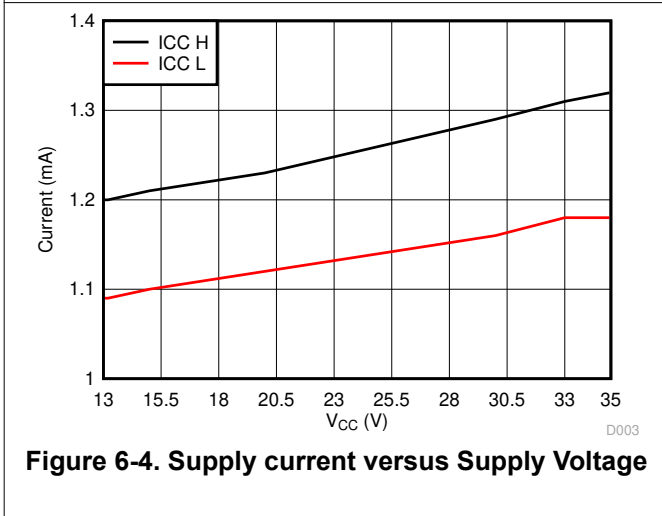
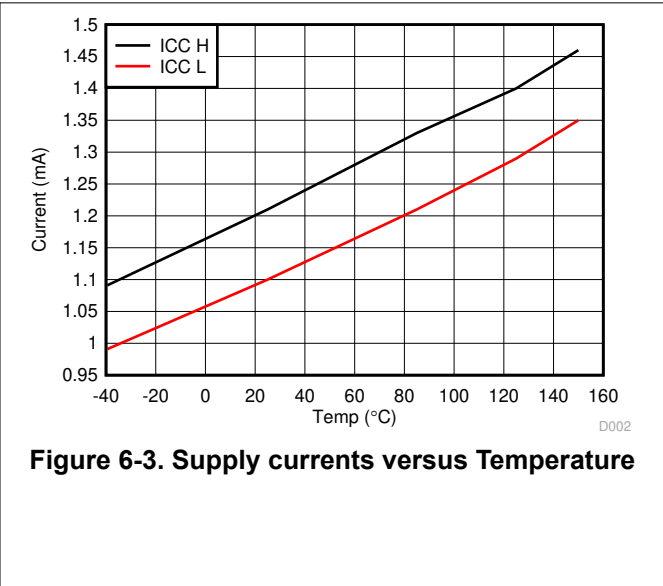
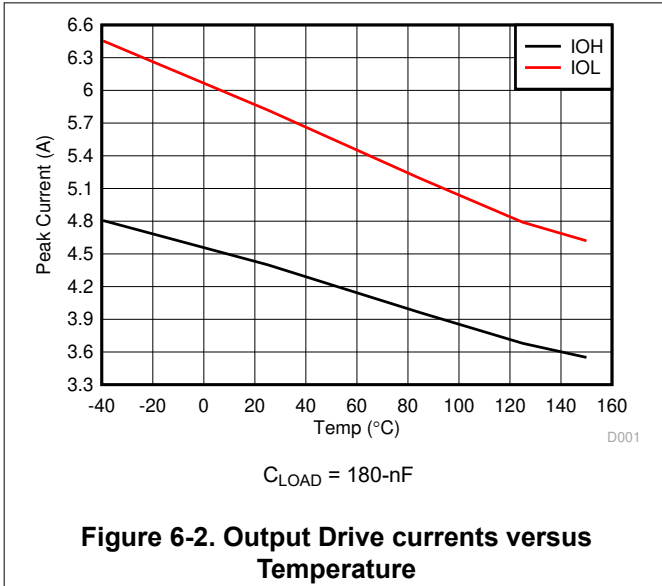
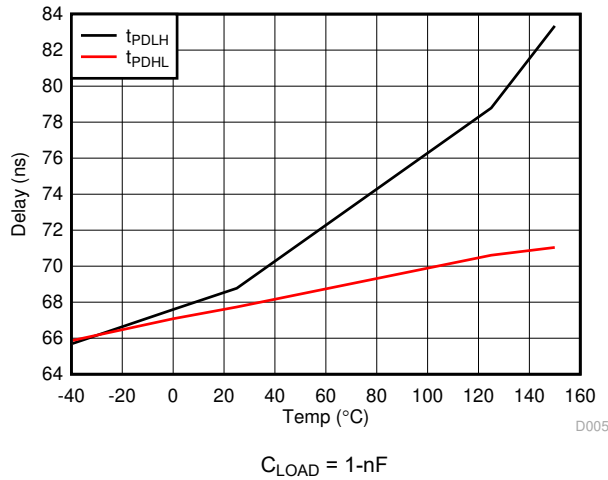


Figure 6-1. Reinforced Isolation Capacitor Life Time Projection

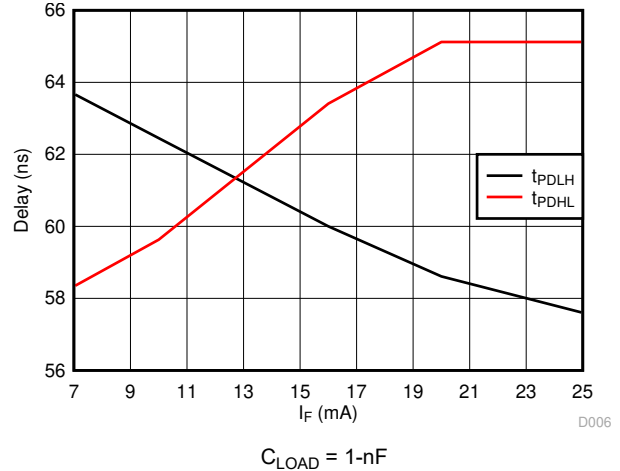
### 6.12 Typical Characteristics

$V_{CC} = 15\text{ V}$ ,  $1\text{-}\mu\text{F}$  capacitor from  $V_{CC}$  to  $V_{EE}$ ,  $C_{LOAD} = 1\text{ nF}$  for timing tests and  $180\text{ nF}$  for  $I_{OH}$  and  $I_{OL}$  tests,  $T_J = -40^\circ\text{C}$  to  $+150^\circ\text{C}$ , (unless otherwise noted)

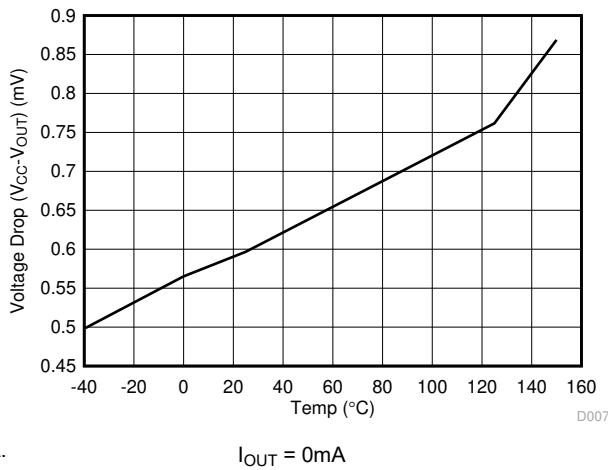




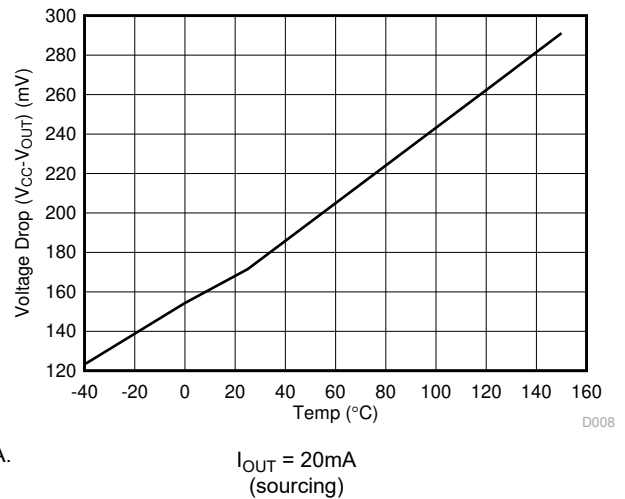
**Figure 6-6. Propagation delay versus Temperature**



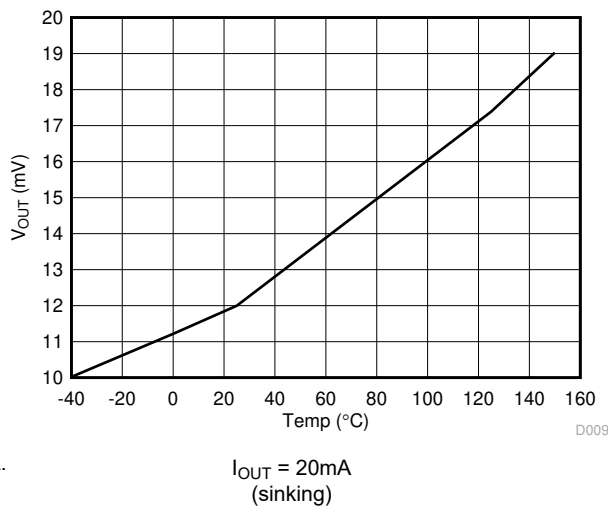
**Figure 6-7. Propagation delay versus Forward current**



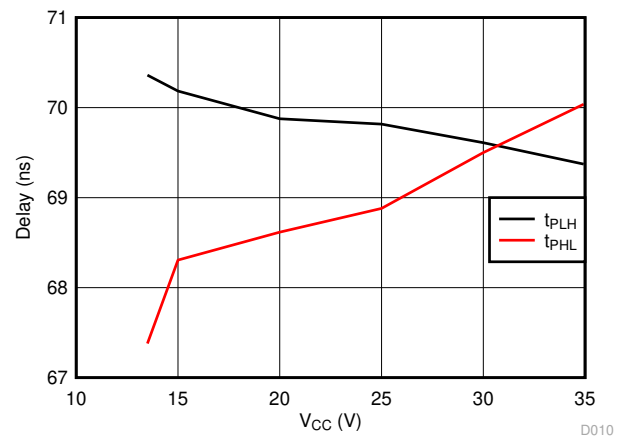
A. **Figure 6-8. V<sub>OH</sub> (No Load) versus Temperature**



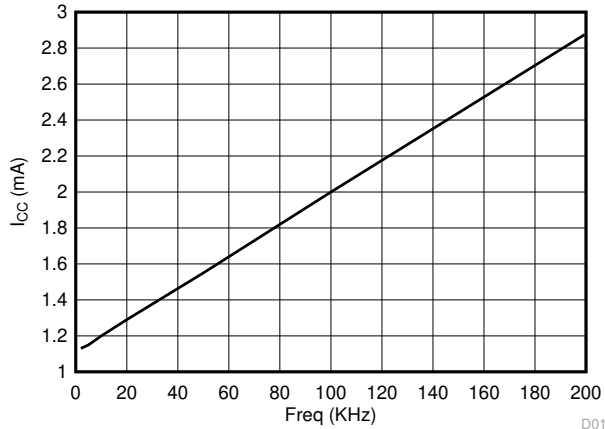
A. **Figure 6-9. V<sub>OH</sub> (20mA Load) versus Temperature**



A. **Figure 6-10. V<sub>OL</sub> versus Temperature**

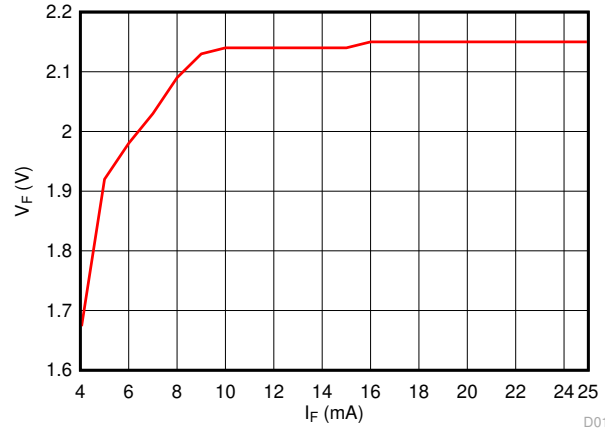


**Figure 6-11. Propagation delay versus Supply voltage**



**Figure 6-12. Supply current versus Frequency**

D011

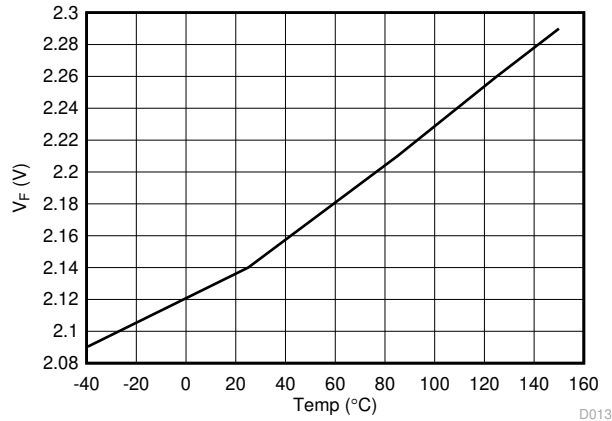


A.

T<sub>A</sub> = 25°C

**Figure 6-13. Forward current versus Forward voltage drop**

D012



A.

I<sub>F</sub> = 10mA

**Figure 6-14. Forward voltage drop versus Temperature**

D013

## 7 Parameter Measurement Information

### 7.1 Propagation Delay, rise time and fall time

Figure 7-1 shows the propagation delay from the input forward current  $I_F$  to  $V_{OUT}$ . This figure also shows the circuit used to measure the rise ( $t_r$ ) and fall ( $t_f$ ) times and the propagation delays  $t_{PD,LH}$  and  $t_{PD,HL}$ .

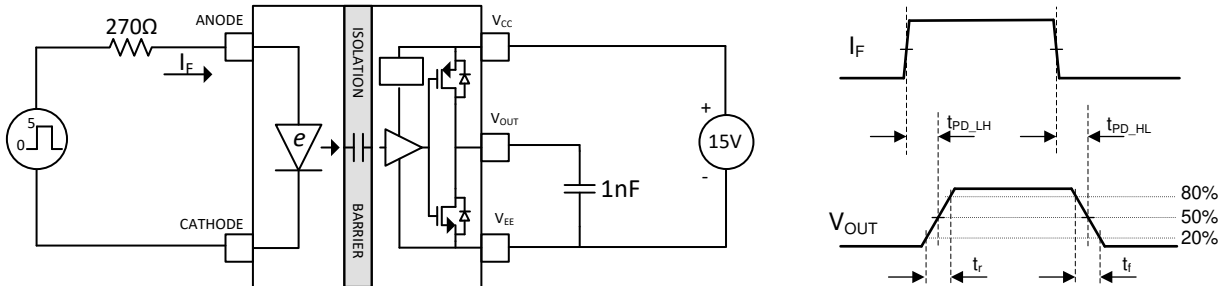


Figure 7-1.  $I_F$  to  $V_{OUT}$  Propagation Delay, Rise Time and Fall Time

### 7.2 $I_{OH}$ and $I_{OL}$ testing

Figure 7-2 shows the circuit used to measure the output drive currents  $I_{OH}$  and  $I_{OL}$ . A load capacitance of 180nF is used at the output. The peak  $dv/dt$  of the capacitor voltage is measured in order to determine the peak source and sink currents of the gate driver.

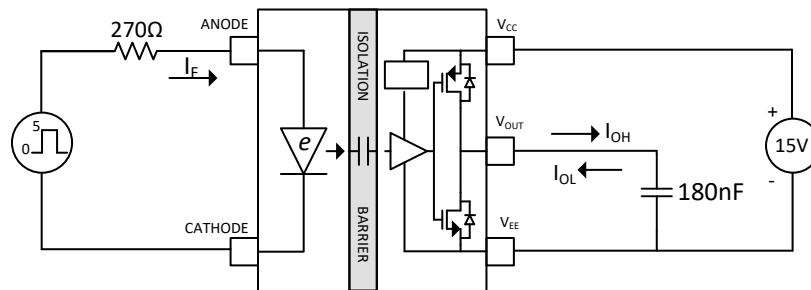


Figure 7-2.  $I_{OH}$  and  $I_{OL}$

### 7.3 CMTI Testing

Figure 7-3 is the simplified diagram of the CMTI testing. Common mode voltage is set to 1500V. The test is performed with  $I_F = 6mA$  ( $V_{OUT} = High$ ) and  $I_F = 0mA$  ( $V_{OUT} = LOW$ ). The diagram also shows the fail criteria for both cases. During the application of the CMTI pulse with  $I_F = 6mA$ , if  $V_{OUT}$  drops from  $V_{CC}$  to  $1/2V_{CC}$  it is considered as a failure. With  $I_F = 0mA$ , if  $V_{OUT}$  rises above 1V, it is considered as a failure.

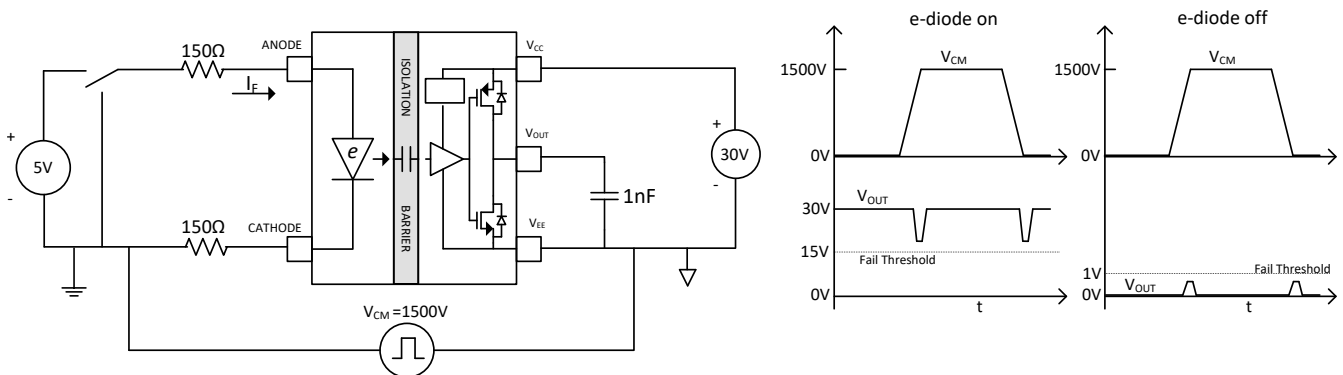


Figure 7-3. CMTI Test Circuit

## 8 Detailed Description

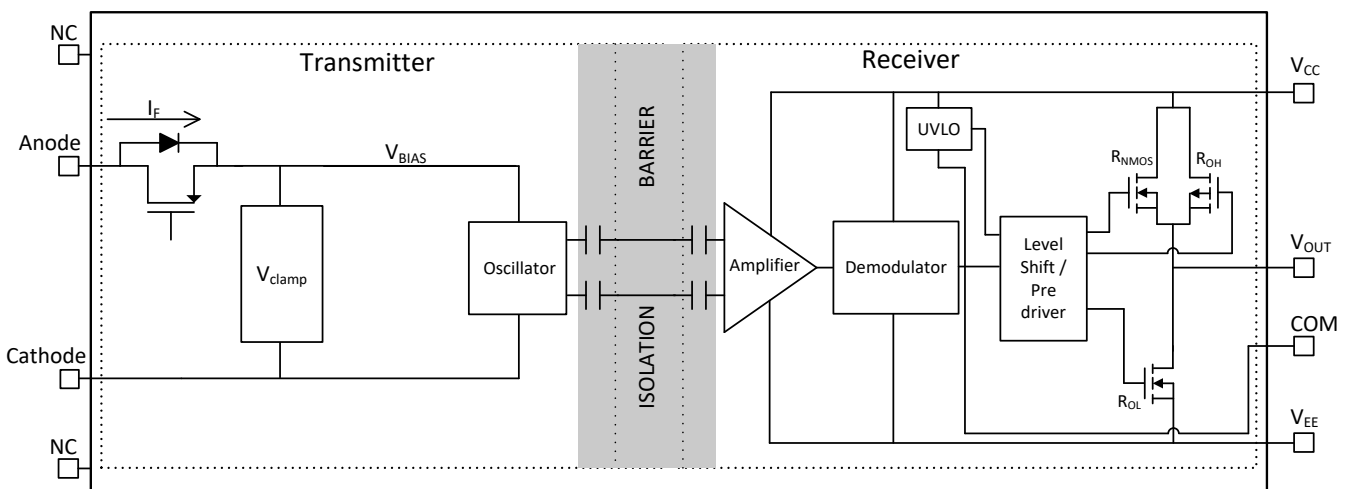
### 8.1 Overview

UCC23514 is a single channel isolated gate driver, with an opto-compatible input stage, that can drive IGBTs, MOSFETs and SiC FETs. It has 4A peak output current capability with max output driver supply voltage of 33V. The inputs and the outputs are galvanically isolated. UCC23514 is offered in an industry standard 8 pin (SOIC) package with >8.5mm creepage and clearance. It has a working voltage of 1500- $V_{RMS}$ , reinforced isolation rating of 5.0- $kV_{RMS}$  for 60s and a surge rating of 8- $kV_{PK}$ . It is pin-to-pin compatible with standard opto isolated gate drivers. While standard opto isolated gate drivers use an LED as the input stage, UCC23514 uses an emulated diode (or "e-diode") as the input stage which does not use light emission to transmit signals across the isolation barrier. The input stage is isolated from the driver stage by dual, series HV  $SiO_2$  capacitors in full differential configuration that not only provides reinforced isolation but also offers best-in-class common mode transient immunity of >150kV/us. The e-diode input stage along with capacitive isolation technology gives UCC23514 several performance advantages over standard opto isolated gate drivers. They are as follows:

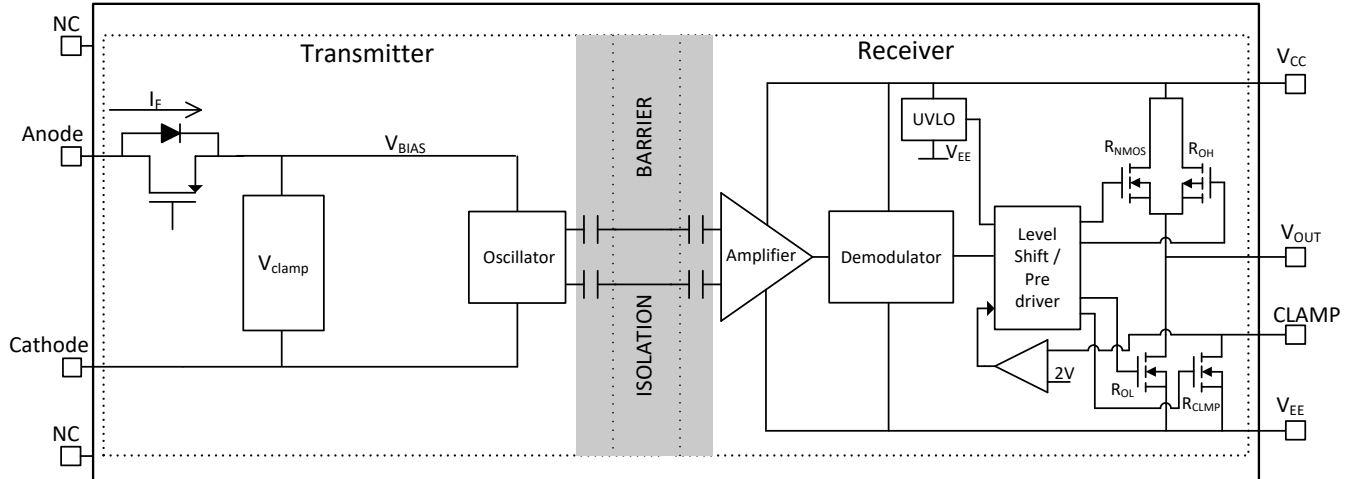
1. Since the e-diode does not use light emission for its operation, the reliability and aging characteristics of UCC23514 are naturally superior to those of standard opto isolated gate drivers.
2. Higher ambient operating temperature range of 125°C, compared to only 105°C for most opto isolated gate drivers
3. The e-diode forward voltage drop has less part-to-part variation and smaller variation across temperature. Hence, the operating point of the input stage is more stable and predictable across different parts and operating temperature.
4. Higher common mode transient immunity than opto isolated gate drivers
5. Smaller propagation delay than opto isolated gate drivers
6. Due to superior process controls achievable in capacitive isolation compared to opto isolation, there is less part-to-part skew in the prop delay, making the system design simpler and more robust
7. Smaller pulse width distortion than opto isolated gate drivers

The signal across the isolation has an on-off keying (OOK) modulation scheme to transmit the digital data across a silicon dioxide based isolation barrier (see Figure 8-4). The transmitter sends a high-frequency carrier across the barrier to represent one digital state and sends no signal to represent the other digital state. The receiver demodulates the signal after advanced signal conditioning and produces the output through a buffer stage. The UCC23514 also incorporates advanced circuit techniques to maximize the CMTI performance and minimize the radiated emissions from the high frequency carrier and IO buffer switching. Figure 8-5 shows conceptual detail of how the OOK scheme works.

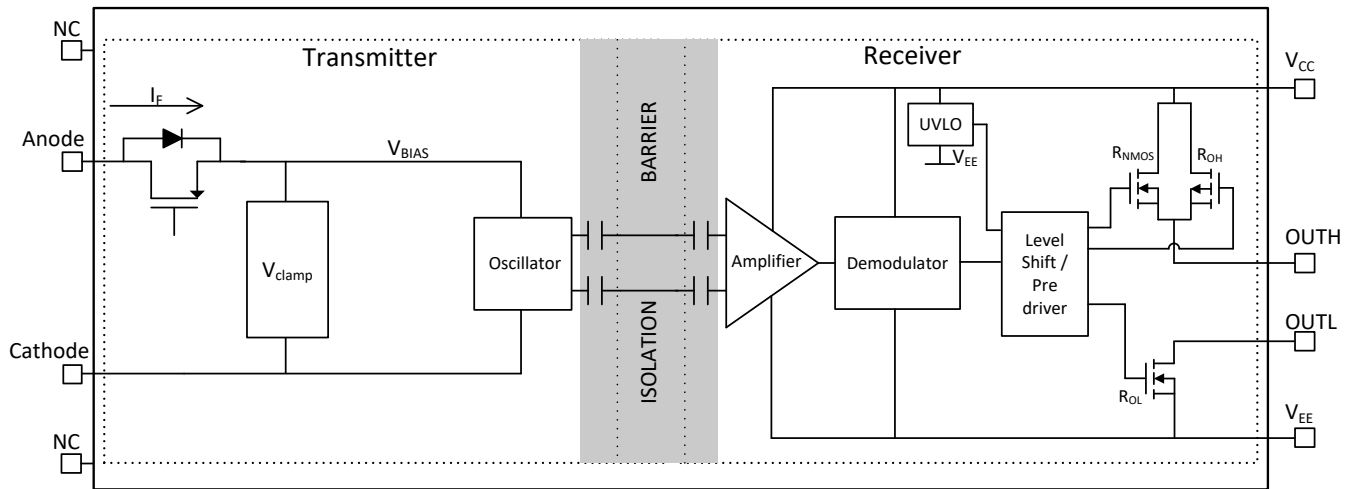
### 8.2 Functional Block Diagram



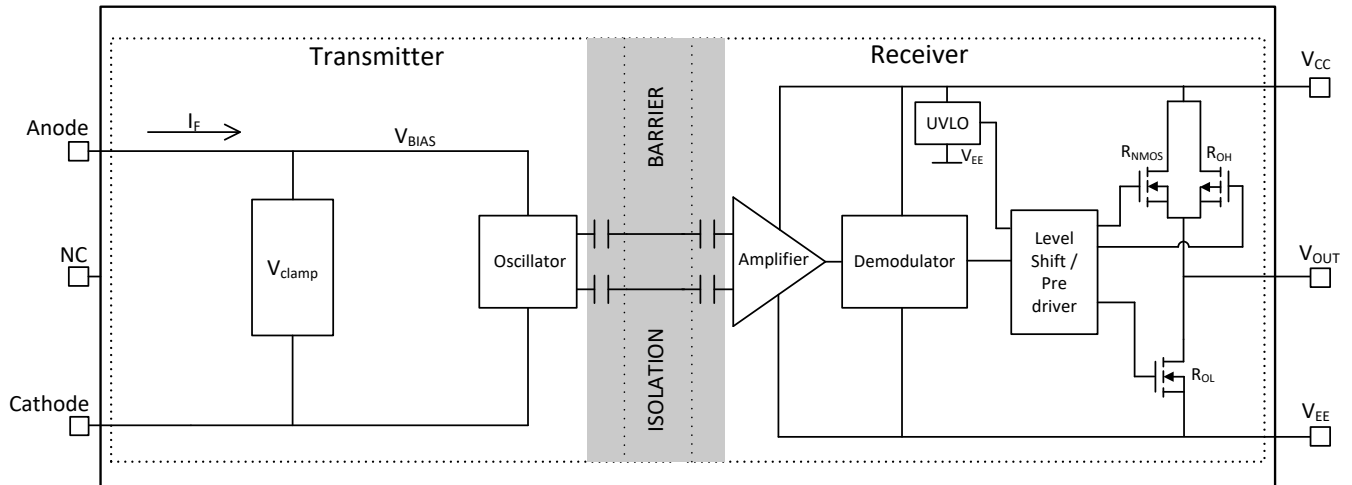
**Figure 8-1. Functional Block Diagram for UCC23514E (COM pin connection to IGBT Emitter)**



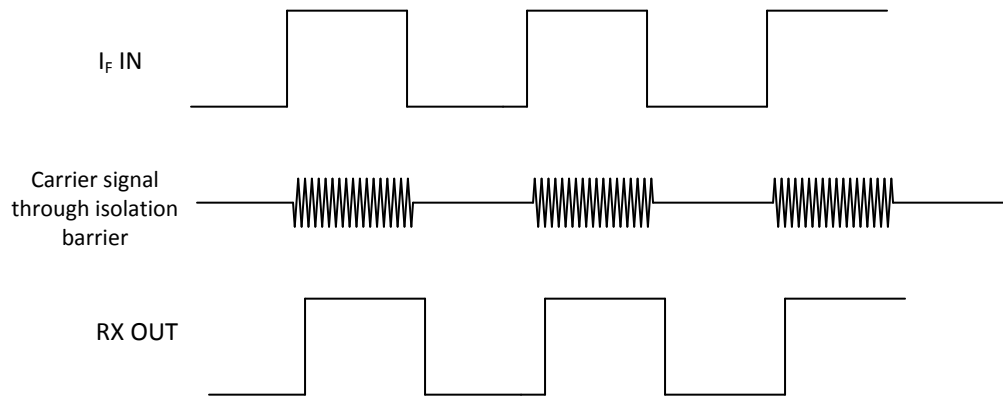
**Figure 8-2. Functional Block Diagram for UCC23514M (Miller clamp)**



**Figure 8-3. Functional Block Diagram for UCC23514S (Split output)**



**Figure 8-4. Functional Block Diagram for UCC23514V (single output pin)**



**Figure 8-5. On-Off Keying (OOK) Based Modulation Scheme**

## 8.3 Feature Description

### 8.3.1 Power Supply

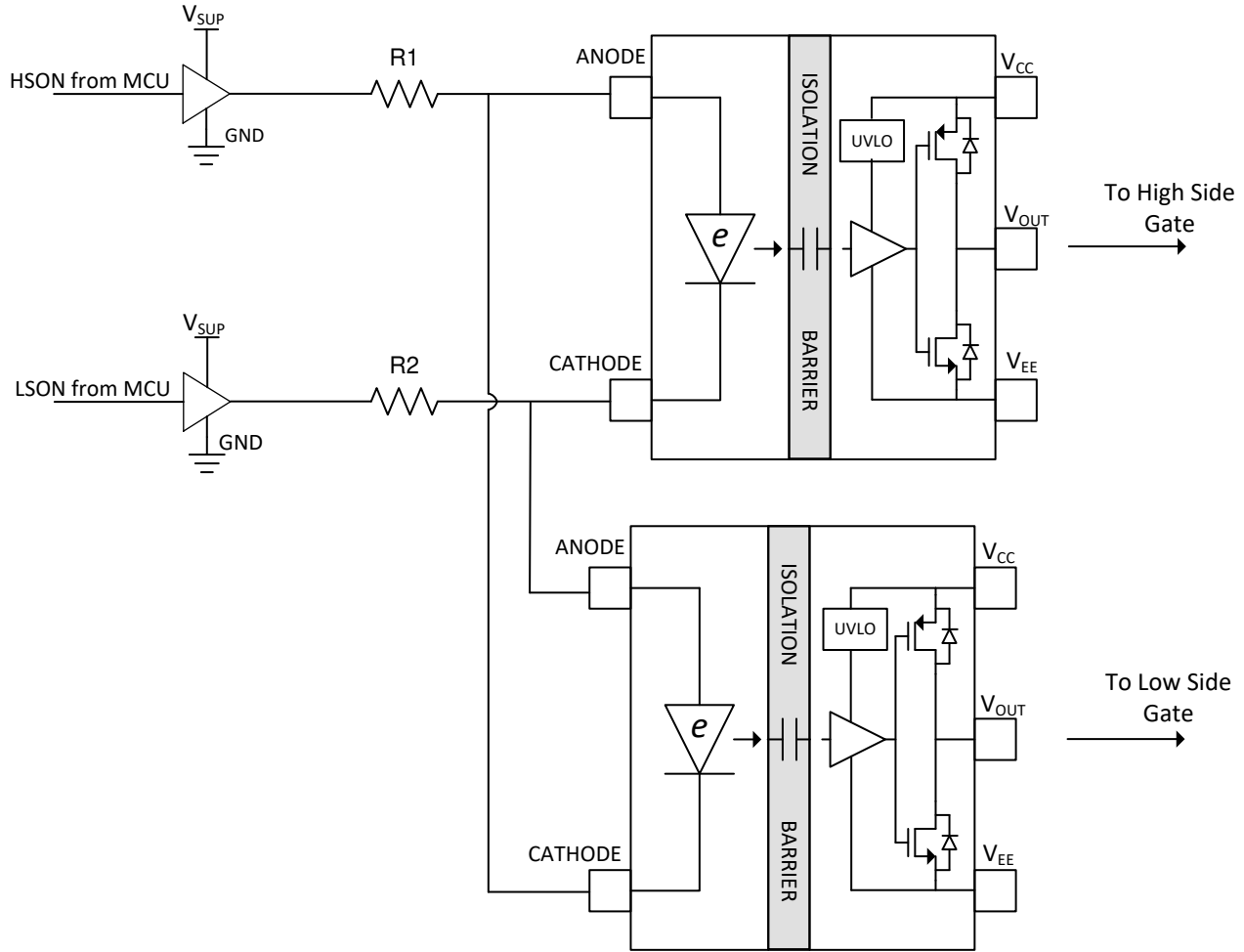
Since the input stage is an emulated diode, no power supply is needed at the input.

The output supply,  $V_{CC}$ , supports a voltage range from 14V to 33V. For operation with bipolar supplies, the power device is turned off with a negative voltage on the gate with respect to the emitter or source. This configuration prevents the power device from unintentionally turning on because of current induced from the Miller effect. The typical values of the  $V_{CC}$  and  $V_{EE}$  output supplies for bipolar operation are 15V and -8V with respect to GND for IGBTs, and 20V and -5V for SiC MOSFETs.

For operation with unipolar supply, the  $V_{CC}$  supply is connected to 15V with respect to GND for IGBTs, and 20V for SiC MOSFETs. The  $V_{EE}$  supply is connected to 0V.

### 8.3.2 Input Stage

The input stage of UCC23514 is simply the e-diode and therefore has an Anode (Pin 1) and a Cathode (Pin 3). Pin 2 has no internal connection and can be left open or connected to ground. The input stage does not have a power and ground pin. When the e-diode is forward biased by applying a positive voltage to the Anode with respect to the Cathode, a forward current  $I_F$  flows into the e-diode. The forward voltage drop across the e-diode is 2.1V (typ). An external resistor should be used to limit the forward current. The recommended range for the forward current is 7mA to 16mA. When  $I_F$  exceeds the threshold current  $I_{FLH}$  (2.8mA typ.) a high frequency signal is transmitted across the isolation barrier through the high voltage SiO<sub>2</sub> capacitors. The HF signal is detected by the receiver and  $V_{OUT}$  is driven high. See [Section 9.2.2.1](#) for information on selecting the input resistor. The dynamic impedance of the e-diode is very small (<1.0Ω) and the temperature coefficient of the e-diode forward voltage drop is <1.35mV/°C. This leads to excellent stability of the forward current  $I_F$  across all operating conditions. If the Anode voltage drops below  $V_{F\_HL}$  (0.9V), or reverse biased, the gate driver output is driven low. The reverse breakdown voltage of the e-diode is >15V. So for normal operation, a reverse bias of up to 13V is allowed. The large reverse breakdown voltage of the e-diode enables UCC23514 to be operated in interlock architecture (see example in [Figure 8-6](#)) where  $V_{SUP}$  can be as high as 12V. The system designer has the flexibility to choose a 3.3V, 5.0V or up to 12V PWM signal source to drive the input stage of UCC23514 using an appropriate input resistor. The example shows two gate drivers driving a set of IGBTs. The inputs of the gate drivers are connected as shown and driven by two buffers that are controlled by the MCU. Interlock architecture prevents both the e-diodes from being "ON" at the same time, preventing shoot through in the IGBTs. It also ensures that if both PWM signals are erroneously stuck high (or low) simultaneously, both gate driver outputs will be driven low.



**Figure 8-6. Interlock**

### 8.3.3 Output Stage

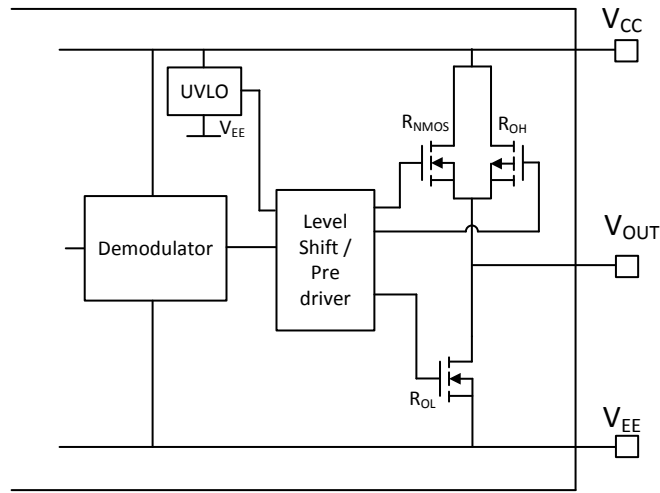
The output stages of the UCC23514 family feature a pullup structure that delivers the highest peak-source current when it is most needed which is during the Miller plateau region of the power-switch turnon transition (when the power-switch drain or collector voltage experiences  $dV/dt$ ). The output stage pullup structure features a P-channel MOSFET and an additional pull-up N-channel MOSFET in parallel. The function of the N-channel MOSFET is to provide a brief boost in the peak-sourcing current, enabling fast turnon. Fast turnon is accomplished by briefly turning on the N-channel MOSFET during a narrow instant when the output is changing states from low to high. The on-resistance of this N-channel MOSFET ( $R_{NMOS}$ ) is approximately  $5.1 \Omega$  when activated.

**Table 8-1. UCC23514 On-Resistance**

$R_{NMOS}$	$R_{OH}$	$R_{OL}$	UNIT
5.1	9.5	0.40	$\Omega$

The  $R_{OH}$  parameter is a DC measurement and is representative of the on-resistance of the P-channel device only. This parameter is only for the P-channel device because the pullup N-channel device is held in the OFF state in DC condition and is turned on only for a brief instant when the output is changing states from low to high. Therefore, the effective resistance of the UCC23514 pullup stage during this brief turnon phase is much lower than what is represented by the  $R_{OH}$  parameter, yielding a faster turn on. The turnon-phase output resistance is the parallel combination  $R_{OH} \parallel R_{NMOS}$ .

The pulldown structure in the UCC23514 is simply composed of an N-channel MOSFET. The output voltage swing between  $V_{CC}$  and  $V_{EE}$  provides rail-to-rail operation because of the MOS-out stage which delivers very low dropout.



**Figure 8-7. Output Stage**

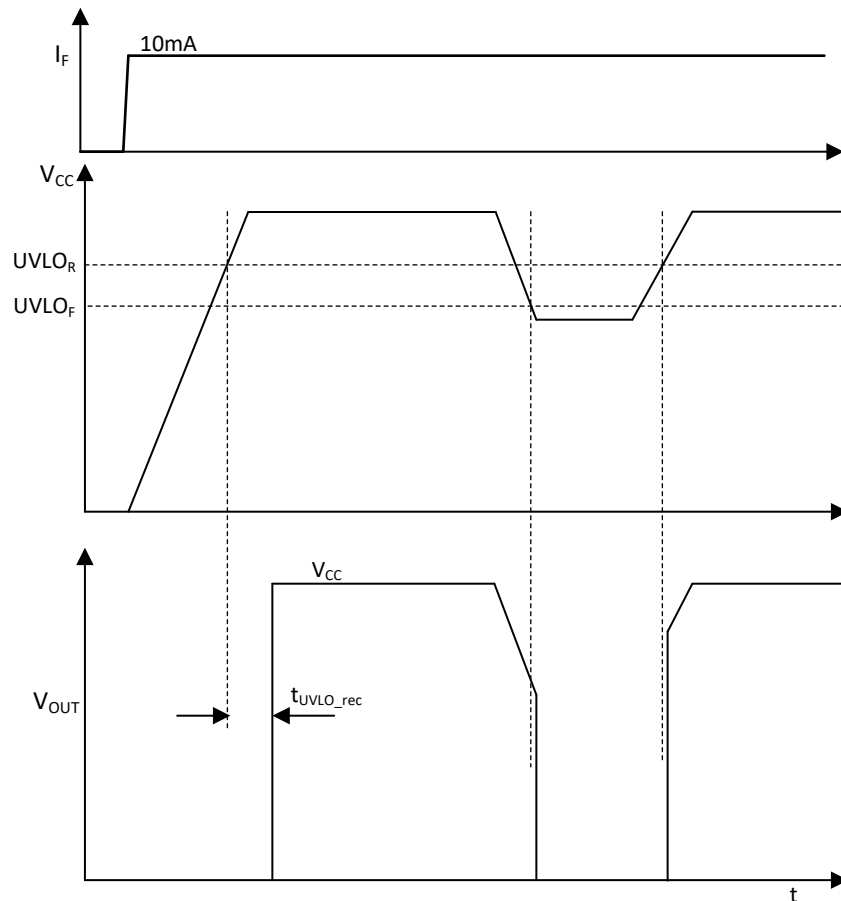
### 8.3.4 Protection Features

#### 8.3.4.1 Undervoltage Lockout (UVLO)

UVLO function is implemented for  $V_{CC}$  and  $V_{EE}$  pins to prevent an under-driven condition on IGBTs and MOSFETs. When  $V_{CC}$  is lower than  $UVLO_R$  at device start-up or lower than  $UVLO_F$  after start-up, the voltage-supply UVLO feature holds the effected output low, regardless of the input forward current as shown in [Table 8-2](#). The  $V_{CC}$  UVLO protection has a hysteresis feature ( $UVLO_{hys}$ ). This hysteresis prevents chatter when the power supply produces ground noise which allows the device to permit small drops in bias voltage, which occurs when the device starts switching and operating current consumption increases suddenly.

When  $V_{CC}$  drops below  $UVLO_F$ , a delay,  $t_{UVLO\_rec}$  occurs on the output when the supply voltage rises above  $UVLO_R$  again.

UVLO is referenced to COM on the UCC23514E, and to  $V_{EE}$  in all other versions.



**Figure 8-8. UVLO functionality**

#### 8.3.4.2 Active Pulldown

The active pull-down function is used to pull the IGBT or MOSFET gate to the low state when no power is connected to the  $V_{CC}$  supply. This feature prevents false IGBT and MOSFET turn-on by clamping  $V_{OUT}$  pin to approximately 2V.

When the output stage of the driver is in an unbiased condition ( $V_{CC}$  floating), the driver outputs (see [Figure 8-7](#)) are held low by an active clamp circuit that limits the voltage rise on the driver outputs. In this condition, the upper PMOS & NMOS are held off while the lower NMOS gate is tied to the driver output through an internal 500-k $\Omega$  resistor. In this configuration, the lower NMOS device effectively clamps the output ( $V_{OUT}$ ) to less than 2V.

#### 8.3.4.3 Short-Circuit Clamping

The short-circuit clamping function is used to clamp voltages at the driver output and pull the output pin  $V_{OUT}$  slightly higher than the  $V_{CC}$  voltage during short-circuit conditions. The short-circuit clamping function helps protect the IGBT or MOSFET gate from overvoltage breakdown or degradation. The short-circuit clamping function is implemented by adding a diode connection between the dedicated pins and the  $V_{CC}$  pin inside the driver. The internal diodes can conduct up to 500-mA current for a duration of 10  $\mu$ s and a continuous current of 20 mA. Use external Schottky diodes to improve current conduction capability as needed.

#### 8.3.4.4 Active Miller Clamp (UCC23514M)

The active Miller-clamp function is used to prevent false turn on of the power switches caused by Miller current in applications where a unipolar power supply is used. The active Miller-clamp function is implemented by adding a low impedance path between the power-switch gate terminal and ground ( $V_{EE}$ ) to sink the Miller current. The Miller clamping function is implemented by adding a low impedance path between the gate of the power device

and the  $V_{EE}$  supply. Miller current sinks through the clamp pin, which clamps the gate voltage to be lower than the gate turn-on threshold value for the power device. The clamp engages whenever the voltage at the CLAMP pin goes below  $V_{CLMP\ TH}$ .

## 8.4 Device Functional Modes

Table 8-2 lists the functional modes for UCC23514

**Table 8-2. Function Table for UCC23514 with VCC Rising**

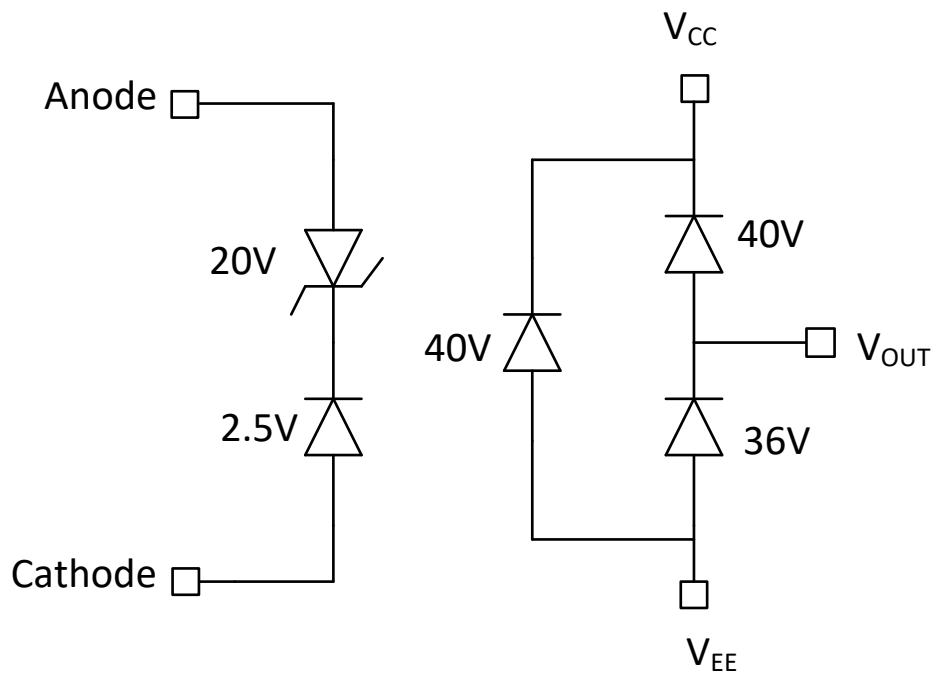
e-diode	VCC	V <sub>OUT</sub>
OFF ( $I_F < I_{FLH}$ )	0V - 33V	Low
ON ( $I_F > I_{FLH}$ )	0V - UVLO <sub>R</sub>	Low
ON ( $I_F > I_{FLH}$ )	UVLO <sub>R</sub> - 33V	High

**Table 8-3. Function Table for UCC23514 with VCC Falling**

e-diode	VCC	V <sub>OUT</sub>
OFF ( $I_F < I_{FLH}$ )	0V - 33V	Low
ON ( $I_F > I_{FLH}$ )	UVLO <sub>F</sub> - 0V	Low
ON ( $I_F > I_{FLH}$ )	33V - UVLO <sub>F</sub>	High

### 8.4.1 ESD Structure

Figure 8-9 shows the multiple diodes involved in the ESD protection components of the UCC23514 device . This provides pictorial representation of the absolute maximum rating for the device.



**Figure 8-9. ESD Structure**

## 9 Application and Implementation

---

### Note

Information in the following applications sections is not part of the TI component specification, and TI does not warrant its accuracy or completeness. TI's customers are responsible for determining suitability of components for their purposes. Customers should validate and test their design implementation to confirm system functionality.

---

### 9.1 Application Information

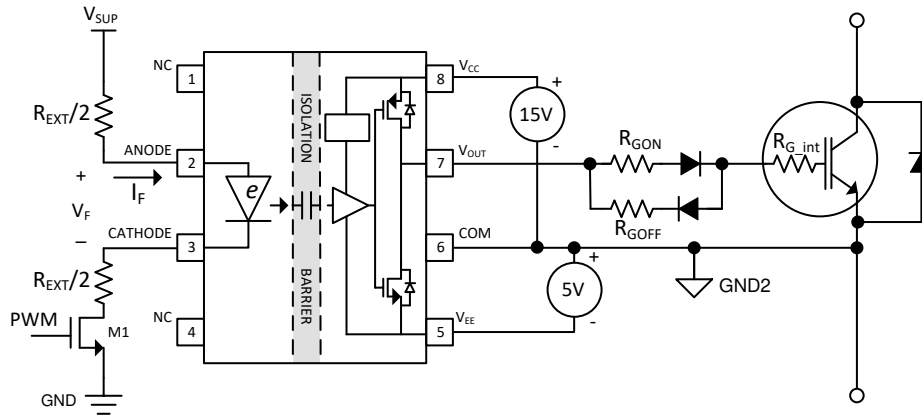
UCC23514 is a single channel, isolated gate driver with opto-compatible input for power semiconductor devices, such as MOSFETs, IGBTs, or SiC MOSFETs. It is intended for use in applications such as motor control, industrial inverters, and switched-mode power supplies. It differs from standard opto isolated gate drivers as it does not have an LED input stage. Instead of an LED, it has an emulated diode (e-diode). To turn the e-diode "ON", a forward current in the range of 7mA to 16mA should be driven into the Anode. This will drive the gate driver output High and turn on the power FET. Typically, MCU's are not capable of providing the required forward current. Hence a buffer has to be used between the MCU and the input stage of UCC23514. Typical buffer power supplies are either 5V or 3.3V. A resistor is needed between the buffer and the input stage of UCC23514 to limit the current. It is simple, but important to choose the right value of resistance. The resistor tolerance, buffer supply voltage tolerance and output impedance of the buffer, have to be considered in the resistor selection. This will ensure that the e-diode forward current stays within the recommended range of 7mA to 16mA. Detailed design recommendations are given in the [Section 9.1](#). The current driven input stage offers excellent noise immunity that is need in high power motor drive systems, especially in cases where the MCU cannot be located close to the isolated gate driver. UCC23514 offers best in class CMTI performance of >150kV/us at 1500V common mode voltages.

The e-diode is capable of 25mA continuous in the forward direction. The forward voltage drop of the e-diode has a very tight part to part variation (1.8V min to 2.4V max). The temperature coefficient of the forward drop is <1.35mV/°C. The dynamic impedance of the e-diode in the forward biased region is ~1Ω. All of these factors contribute in excellent stability of the e-diode forward current. To turn the e-diode "OFF", the Anode - Cathode voltage should be <0.8V, or  $I_F$  should be < $I_{FLH}$ . The e-diode can also be reverse biased up to 13V (14V abs max) in order to turn it off and bring the gate driver output low. The large reverse breakdown voltage of the input stage provides system designers the flexibility to drive the input stage with 12V PWM signals without the need for an additional clamping circuit on the Anode and Cathode pin.

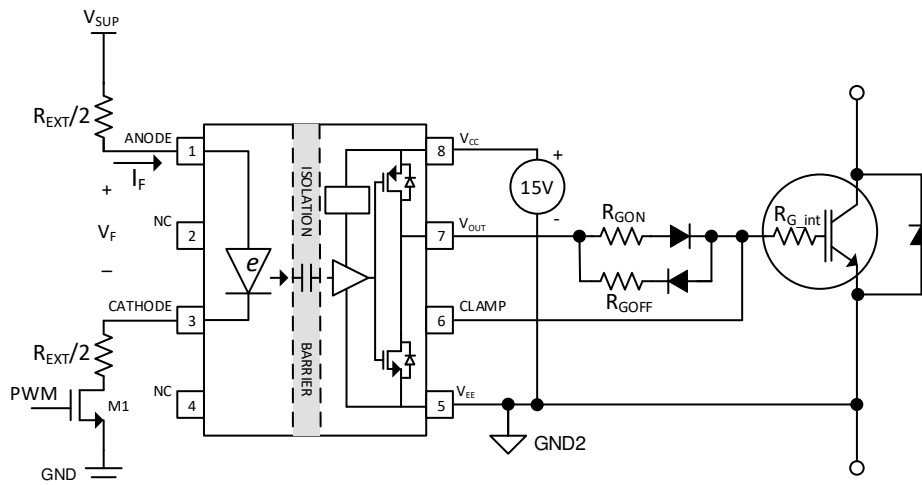
The output power supply for UCC23514 can be as high as 33V (35V abs max). The output power supply can be configured externally as a single isolated supply up to 33V or isolated bipolar supply such that  $V_{CC}-V_{EE}$  does not exceed 33V, or it can be bootstrapped (with external diode & capacitor) if the system uses a single power supply with respect to the power ground. Typical quiescent power supply current from  $V_{CC}$  is 1.2mA (max 2.2mA).

## 9.2 Typical Application

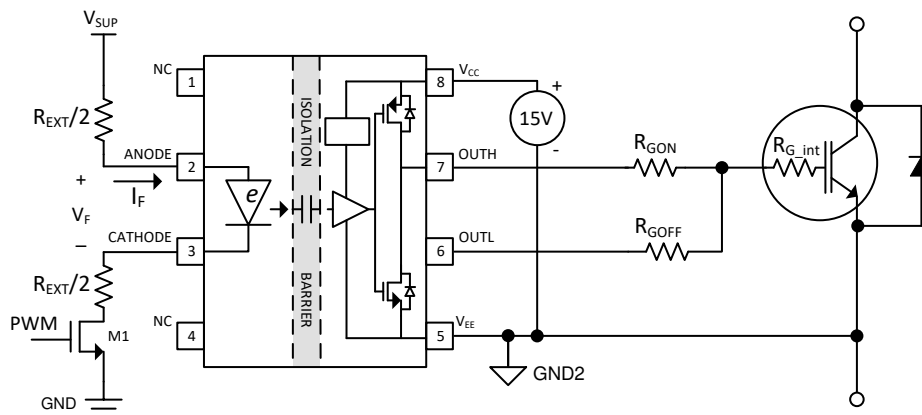
The circuit in Figure 9-2, shows a typical application for driving IGBTs.



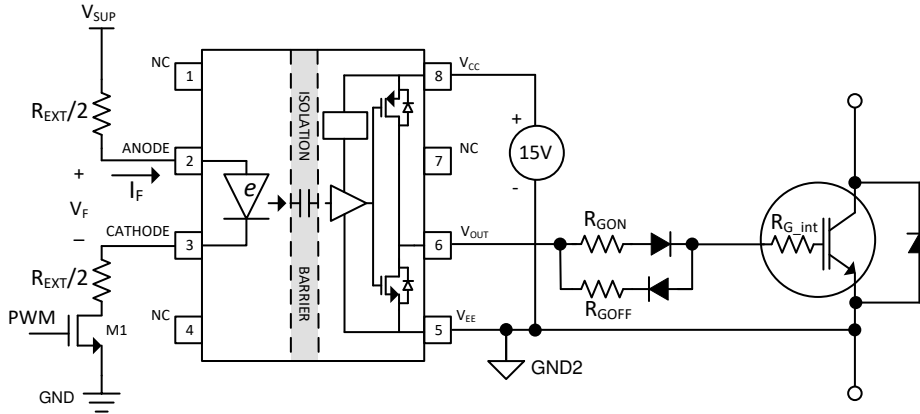
**Figure 9-1. Typical Application Circuit for UCC23514E to Drive IGBT with Split Gate Drive Supply**



**Figure 9-2. Typical Application Circuit for UCC23514M to Drive IGBT**



**Figure 9-3. Typical Application Circuit for UCC23514S to Drive IGBT**



**Figure 9-4. Typical Application Circuit for UCC23514V to Drive IGBT**

### 9.2.1 Design Requirements

Table 9-1 lists the recommended conditions to observe the input and output of the UCC23514 gate driver.

**Table 9-1. UCC23514 Design Requirements**

PARAMETER	VALUE	UNIT
$V_{CC}$	15	V
$I_F$	10	mA
Switching frequency	8	kHz

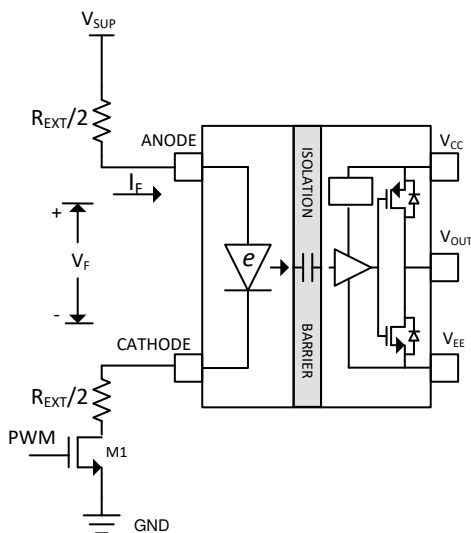
## 9.2.2 Detailed Design Procedure

### 9.2.2.1 Selecting the Input Resistor

The input resistor limits the current that flows into the e-diode when it is forward biased. The threshold current  $I_{FLH}$  is 2.8 mA typ. The recommended operating range for the forward current is 7 mA to 16 mA (e-diode ON). All the electrical specifications are guaranteed in this range. The resistor should be selected such that for typical operating conditions,  $I_F$  is 10mA. Following are the list of factors that will affect the exact value of this current:

1. Supply Voltage  $V_{SUP}$  variation
2. Manufacturer's tolerance for the resistor and variation due to temperature
3. e-diode forward voltage drop variation (at  $I_F=10\text{mA}$ ,  $V_F=$  typ 2.1 V, min 1.8 V, max 2.4 V, with a temperature coefficient  $<1.35\text{ mV}/^\circ\text{C}$  and dynamic impedance  $<1\Omega$ )

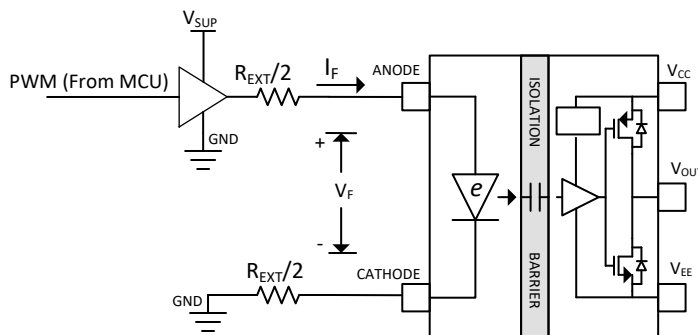
See [Figure 9-5](#) for the schematic using a single NMOS and split resistor combination to drive the input stage of UCC23514. The input resistor can be selected using the equation shown.



$$R_{EXT} = \frac{V_{SUP} - V_F}{I_F} - R_{M1}$$

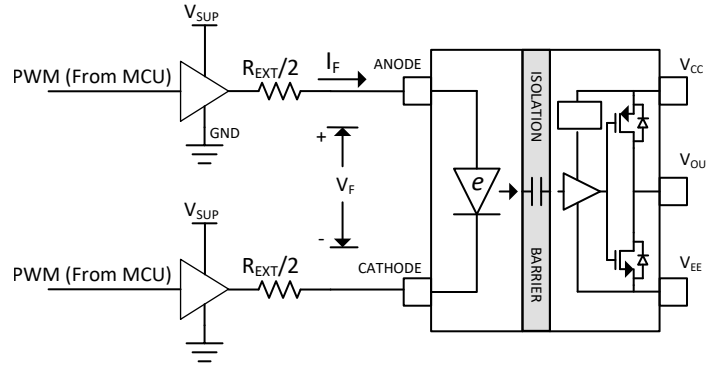
**Figure 9-5. Configuration 1: Driving the input stage of UCC23514 with a single NMOS and split resistors**

Driving the input stage of UCC23514 using a single buffer is shown in [Figure 9-6](#) and using 2 buffers is shown in [Figure 9-7](#)



$$R_{EXT} = \frac{V_{SUP} - V_F}{I_F} - R_{OH\_buf}$$

**Figure 9-6. Configuration 2: Driving the input stage of UCC23514 with one Buffer and split resistors**



$$R_{EXT} = \frac{V_{SUP} - V_F}{I_F} - (R_{OH\_buf} + R_{OL\_buf})$$

**Figure 9-7. Configuration 3: Driving the input stage of UCC23514 with 2 buffers and split resistors**

Table 9-2 shows the range of values for  $R_{EXT}$  for the 3 different configurations shown in Figure 9-5, Figure 9-6 and Figure 9-7. The assumptions used in deriving the range for  $R_{EXT}$  are as follows:

1. Target forward current  $I_F$  is 7mA min, 10mA typ and 16mA max
2. e-diode forward voltage drop is 1.8V to 2.4V
3.  $V_{SUP}$  (Buffer supply voltage) is 5V with  $\pm 5\%$  tolerance
4. Manufacturer's tolerance for  $R_{EXT}$  is 1%
5. NMOS resistance is 0.25 $\Omega$  to 1.0 $\Omega$  (for configuration 1)
6.  $R_{OH}$ (buffer output impedance in output "High" state) is 13 $\Omega$  min, 18 $\Omega$  typ and 22 $\Omega$  max
7.  $R_{OL}$ (buffer output impedance in "Low" state) is 10 $\Omega$  min, 14 $\Omega$  typ and 17 $\Omega$  max

**Table 9-2.  $R_{EXT}$  Values to Drive The Input Stage**

Configuration	$R_{EXT} \Omega$		
	Min	Typ	Max
Single NMOS and $R_{EXT}$	218	290	331
Single Buffer and $R_{EXT}$	204	272	311
Two Buffers and $R_{EXT}$	194	259	294

### 9.2.2.2 Gate-Driver Output Resistor

The external gate-driver resistors,  $R_{G(ON)}$  and  $R_{G(OFF)}$  are used to:

1. Limit ringing caused by parasitic inductances and capacitances
2. Limit ringing caused by high voltage or high current switching  $dv/dt$ ,  $di/dt$ , and body-diode reverse recovery
3. Fine-tune gate drive strength, specifically peak sink and source current to optimize the switching loss
4. Reduce electromagnetic interference (EMI)

The output stage has a pull up structure consisting of a P-channel MOSFET and an N-channel MOSFET in parallel. The combined peak source current is 4.5 A Use Equation 1 to estimate the peak source current as an example.

$$I_{OH} = \min \left[ 4.5A, \frac{V_{CC} - V_{GDF}}{(R_{NMOS} || R_{OH} + R_{GON} + R_{GFET_{INT}})} \right] \quad (1)$$

where

- $R_{GON}$  is the external turnon resistance.
- $R_{GFET\_Int}$  is the power transistor internal gate resistance, found in the power transistor data sheet. We will assume  $0\Omega$  for our example
- $I_{OH}$  is the peak source current which is the minimum value between 4.5A, the gate-driver peak source current, and the calculated value based on the gate-drive loop resistance.
- $V_{GDF}$  is the forward voltage drop for each of the diodes in series with  $R_{GON}$  and  $R_{GOFF}$ . The diode drop for this example is 0.7 V.

In this example, the peak source current is approximately 1.7A as calculated in [Equation 2](#).

$$I_{OH} = \min \left[ 4.5A, \frac{15 - 0.7}{(5.1\Omega || 9.5\Omega + 5\Omega + 0\Omega)} \right] = 1.72A \quad (3)$$

Similarly, use [Equation 3](#) to calculate the peak sink current.

$$I_{OL} = \min \left[ 5.3A, \frac{V_{CC} - V_{GDF}}{(R_{OL} + R_{GOFF} + R_{GFET\_INT})} \right] \quad (4)$$

where

- $R_{GOFF}$  is the external turnoff resistance.
- $I_{OL}$  is the peak sink current which is the minimum value between 5.3A, the gate-driver peak sink current, and the calculated value based on the gate-drive loop resistance.

In this example, the peak sink current is the minimum of [Equation 4](#) and 5.3A.

$$I_{OL} = \min \left[ 5.3A, \frac{15 - 0.7}{(0.4\Omega + 10\Omega + 0\Omega)} \right] = 1.38A \quad (6)$$

The diodes shown in series with each,  $R_{GON}$  and  $R_{GOFF}$ , in [Figure 9-1](#), [Figure 9-2](#), and [Figure 9-4](#) ensure the gate drive current flows through the intended path, respectively, during turn-on and turn-off. Note that the diode forward drop will reduce the voltage level at the gate of the power switch. To achieve rail-to-rail gate voltage levels, add a resistor from the  $V_{OUT}$  pin to the power switch gate, with a resistance value approximately 20 times higher than  $R_{GON}$  and  $R_{GOFF}$ . For the examples described in this section, a good choice is 100  $\Omega$  to 200  $\Omega$ .

The UCC23514S provides split output pins, OUTH and OUTL, which provide separate paths for turn-on and turn-off current. The series diodes are not necessary when this device option is used, as shown in [Figure 9-3](#). For this case, substitute  $V_{GDF} = 0$  V in the equations above. The UCC23514S provides rail-to-rail gate voltage levels without need for additional parallel resistors.

---

#### Note

The estimated peak current is also influenced by PCB layout and load capacitance. Parasitic inductance in the gate-driver loop can slow down the peak gate-drive current and introduce overshoot and undershoot. Therefore, TI strongly recommends that the gate-driver loop should be minimized. Conversely, the peak source and sink current is dominated by loop parasitics when the load capacitance ( $C_{ISS}$ ) of the power transistor is very small (typically less than 1 nF) because the rising and falling time is too small and close to the parasitic ringing period.

---

### 9.2.2.3 Estimate Gate-Driver Power Loss

The total loss,  $P_G$ , in the gate-driver subsystem includes the power losses ( $P_{GD}$ ) of the UCC23514 device and the power losses in the peripheral circuitry, such as the external gate-drive resistor.

The  $P_{GD}$  value is the key power loss which determines the thermal safety-related limits of the UCC23514 device, and it can be estimated by calculating losses from several components.

The first component is the static power loss,  $P_{GDQ}$ , which includes power dissipated in the input stage ( $P_{GDQ\_IN}$ ) as well as the quiescent power dissipated in the output stage ( $P_{GDQ\_OUT}$ ) when operating with a certain switching frequency under no load.  $P_{GDQ\_IN}$  is determined by  $I_F$  and  $V_F$  and is given by Equation 5. The  $P_{GDQ\_OUT}$  parameter is measured on the bench with no load connected to  $V_{OUT}$  pin at a given  $V_{CC}$ , switching frequency, and ambient temperature. In this example,  $V_{CC}$  is 15 V. The current on the power supply, with PWM switching at 10 kHz, is measured to be  $I_{CC} = 1.33$  mA. Therefore, use Equation 6 to calculate  $P_{GDQ\_OUT}$ .

$$P_{GDQ\_IN} = \frac{1}{2} * V_F * I_F \tag{7}$$

$$P_{GDQ\_OUT} = V_{CC} * I_{CC} \tag{8}$$

The total quiescent power (without any load capacitance) dissipated in the gate driver is given by the sum of Equation 5 and Equation 6 as shown in Equation 7

$$P_{GDQ} = P_{GDQ\_IN} + P_{GDQ\_OUT} = 10 \text{ mW} + 20\text{mW} = 30\text{mW} \tag{9}$$

The second component is the switching operation loss,  $P_{GDSW}$ , with a given load capacitance which the driver charges and discharges the load during each switching cycle. Use Equation 8 to calculate the total dynamic loss from load switching,  $P_{GSW}$ .

$$P_{GSW} = V_{CC} * Q_G * f_{SW} \tag{10}$$

where

- $Q_G$  is the gate charge of the power transistor at  $V_{CC}$ .

So, for this example application the total dynamic loss from load switching is approximately 18 mW as calculated in Equation 9.

$$P_{GSW} = 15 \text{ V} * 120 \text{ nC} * 10 \text{ kHz} = 18 \text{ mW} \tag{11}$$

$Q_G$  represents the total gate charge of the power transistor switching 520 V at 50 A, and is subject to change with different testing conditions. The UCC23514 gate-driver loss on the output stage,  $P_{GDO}$ , is part of  $P_{GSW}$ .  $P_{GDO}$  is equal to  $P_{GSW}$  if the external gate-driver resistance and power-transistor internal resistance are 0  $\Omega$ , and all the gate driver-loss will be dissipated inside the UCC23514. If an external turn-on and turn-off resistance exists, the total loss is distributed between the gate driver pull-up/down resistance, external gate resistance, and power-transistor internal resistance. Importantly, the pull-up/down resistance is a linear and fixed resistance if the source/sink current is not saturated to 4.5A/5.3A, however, it will be non-linear if the source/sink current is saturated. Therefore,  $P_{GDO}$  is different in these two scenarios.

#### Case 1 - Linear Pull-Up/Down Resistor:

$$P_{GDO} = \frac{P_{GSW}}{2} \left[ \frac{R_{OH} || R_{NMOS}}{R_{OH} || R_{NMOS} + R_{GON} + R_{GFET\_int}} + \frac{R_{OL}}{R_{OL} + R_{GOFF} + R_{GFET\_int}} \right] \quad (12)$$

In this design example, all the predicted source and sink currents are less than 4.5 A and 5.3 A, therefore, use [Equation 10](#) to estimate the UCC23514 gate-driver loss.

$$P_{GDO} = \frac{18 \text{ mW}}{2} \left[ \frac{9.5\Omega || 5.1\Omega}{9.5\Omega || 5.1\Omega + 5.1\Omega + 0\Omega} + \frac{0.4\Omega}{0.4\Omega + 10\Omega + 0\Omega} \right] = 3.9 \text{ mW} \quad (13)$$

### Case 2 - Nonlinear Pull-Up/Down Resistor:

$$P_{GDO} = f_{sw} \times \left[ 4.5A \times \int_0^{T_{R\_Sys}} (V_{CC} - V_{OUT}(t)) dt + 5.3A \times \int_0^{T_{F\_Sys}} V_{OUT}(t) dt \right] \quad (14)$$

where

- $V_{OUT}(t)$  is the gate-driver OUT pin voltage during the turnon and turnoff period. In cases where the output is saturated for some time, this value can be simplified as a constant-current source (4.5 A at turnon and 5.3 A at turnoff) charging or discharging a load capacitor. Then, the  $V_{OUT}(t)$  waveform will be linear and the  $T_{R\_Sys}$  and  $T_{F\_Sys}$  can be easily predicted.

For some scenarios, if only one of the pullup or pulldown circuits is saturated and another one is not, the  $P_{GDO}$  is a combination of case 1 and case 2, and the equations can be easily identified for the pullup and pulldown based on this discussion.

Use [Equation 13](#) to calculate the total gate-driver loss dissipated in the UCC23514 gate driver,  $P_{GD}$ .

$$P_{GD} = P_{GDQ} + P_{GDO} = 30\text{mW} + 3.9\text{mW} = 33.9\text{mW} \quad (15)$$

#### 9.2.2.4 Estimating Junction Temperature

Use [Equation 14](#) to estimate the junction temperature ( $T_J$ ) of UCC23514.

$$T_J = T_C + \Psi_{JT} \times P_{GD} \quad (16)$$

where

- $T_C$  is the UCC23514 case-top temperature measured with a thermocouple or some other instrument.
- $\Psi_{JT}$  is the junction-to-top characterization parameter from the [Section 6.4](#) table.

Using the junction-to-top characterization parameter ( $\Psi_{JT}$ ) instead of the junction-to-case thermal resistance ( $R_{\theta JC}$ ) can greatly improve the accuracy of the junction temperature estimation. The majority of the thermal energy of most ICs is released into the PCB through the package leads, whereas only a small percentage of the total energy is released through the top of the case (where thermocouple measurements are usually conducted). The  $R_{\theta JC}$  resistance can only be used effectively when most of the thermal energy is released through the case, such as with metal packages or when a heat sink is applied to an IC package. In all other cases, use of  $R_{\theta JC}$  will inaccurately estimate the true junction temperature. The  $\Psi_{JT}$  parameter is experimentally derived by assuming that the dominant energy leaving through the top of the IC will be similar in both the testing environment and the application environment. As long as the recommended layout guidelines are observed, junction temperature estimations can be made accurately to within a few degrees Celsius.

### 9.2.2.5 Selecting $V_{CC}$ Capacitor

Bypass capacitors for  $V_{CC}$  is essential for achieving reliable performance. TI recommends choosing low-ESR and low-ESL, surface-mount, multi-layer ceramic capacitors (MLCC) with sufficient voltage ratings, temperature coefficients, and capacitance tolerances. A 50-V, 10- $\mu$ F MLCC and a 50-V, 0.22- $\mu$ F MLCC are selected for the  $C_{VCC}$  capacitor. If the bias power supply output is located a relatively long distance from the  $V_{CC}$  pin, a tantalum or electrolytic capacitor with a value greater than 10  $\mu$ F should be used in parallel with  $C_{VCC}$ .

---

#### Note

DC bias on some MLCCs will impact the actual capacitance value. For example, a 25-V, 1- $\mu$ F X7R capacitor is measured to be only 500 nF when a DC bias of 15- $V_{DC}$  is applied.

---

## 10 Power Supply Recommendations

The recommended input supply voltage ( $V_{CC}$ ) for the UCC23514 device is from 14V to 33V. The lower limit of the range of output bias-supply voltage ( $V_{CC}$ ) is determined by the internal UVLO protection feature of the device.  $V_{CC}$  voltage should not fall below the UVLO threshold for normal operation, or else the gate-driver outputs can become clamped low for more than 20  $\mu$ s by the UVLO protection feature. UVLO is referenced to COM on the UCC23514E, and to  $V_{EE}$  in all other versions. The higher limit of the  $V_{CC}$  range depends on the maximum gate voltage of the power device that is driven by the UCC23514 device, and should not exceed the recommended maximum  $V_{CC}$  of 33 V. A local 220-nF to 10- $\mu$ F bypass capacitor should be placed between the  $V_{CC}$  and COM pins for the UCC23514E, or between the  $V_{CC}$  and  $V_{EE}$  pins for all other versions. TI recommends placing an additional 100-nF capacitor in parallel with the device biasing capacitor for high frequency filtering. Both capacitors should be positioned as close to the device pins as possible. Low-ESR, ceramic surface-mount capacitors are recommended.

If only a single, primary-side power supply is available in an application, isolated power can be generated for the secondary side with the help of a transformer driver such as Texas Instruments' [SN6501](#) or [SN6505A](#). For such applications, detailed power supply design and transformer selection recommendations are available in [SN6501 Transformer Driver for Isolated Power Supplies data sheet](#) and [SN6505A Low-Noise 1-A Transformer Drivers for Isolated Power Supplies data sheet](#).

## 11 Layout

### 11.1 Layout Guidelines

Designers must pay close attention to PCB layout to achieve optimum performance for the UCC23514. Some key guidelines are:

- Component placement:
  - Low-ESR and low-ESL capacitors must be connected close to the device between the  $V_{CC}$  and  $V_{EE}$  pins to bypass noise and to support high peak currents when turning on the external power transistor.
  - To avoid large negative transients on the  $V_{EE}$  pins connected to the switch node, the parasitic inductances between the source of the top transistor and the source of the bottom transistor must be minimized.
- Grounding considerations:
  - Limiting the high peak currents that charge and discharge the transistor gates to a minimal physical area is essential. This limitation decreases the loop inductance and minimizes noise on the gate terminals of the transistors. The gate driver must be placed as close as possible to the transistors.
- High-voltage considerations:
  - To ensure isolation performance between the primary and secondary side, avoid placing any PCB traces or copper below the driver device. A PCB cutout or groove is recommended in order to prevent contamination that may compromise the isolation performance.
- Thermal considerations:
  - A large amount of power may be dissipated by the UCC23514 if the driving voltage is high, the load is heavy, or the switching frequency is high. Proper PCB layout can help dissipate heat from the device to the PCB and minimize junction-to-board thermal impedance ( $\theta_{JB}$ ).
  - Increasing the PCB copper connecting to the  $V_{CC}$  and  $V_{EE}$  pins is recommended, with priority on maximizing the connection to  $V_{EE}$ . However, the previously mentioned high-voltage PCB considerations must be maintained.
  - If the system has multiple layers, TI also recommends connecting the  $V_{CC}$  and  $V_{EE}$  pins to internal ground or power planes through multiple vias of adequate size. These vias should be located close to the IC pins to maximize thermal conductivity. However, keep in mind that no traces or coppers from different high voltage planes are overlapping.

### 11.2 PCB Material

Use standard FR-4 UL94V-0 printed circuit board. This PCB is preferred over cheaper alternatives because of lower dielectric losses at high frequencies, less moisture absorption, greater strength and stiffness, and the self-extinguishing flammability-characteristics.

## 12 Mechanical, Packaging, and Orderable Information

The following pages include mechanical, packaging, and orderable information. This information is the most current data available for the designated devices. This data is subject to change without notice and revision of this document. For browser-based versions of this data sheet, refer to the left-hand navigation.

**PACKAGING INFORMATION**

Orderable part number	Status (1)	Material type (2)	Package   Pins	Package qty   Carrier	RoHS (3)	Lead finish/ Ball material (4)	MSL rating/ Peak reflow (5)	Op temp (°C)	Part marking (6)
<a href="#">UCC23514EDWV</a>	Obsolete	Production	SOIC (DWV)   8	-	-	Call TI	Call TI	-40 to 125	23514E
<a href="#">UCC23514EDWVR</a>	Active	Production	SOIC (DWV)   8	1000   LARGE T&R	Yes	NIPDAU	Level-2-260C-1 YEAR	-40 to 125	23514E
<a href="#">UCC23514EDWVR.B</a>	Active	Production	SOIC (DWV)   8	1000   LARGE T&R	Yes	NIPDAU	Level-2-260C-1 YEAR	-40 to 125	23514E
<a href="#">UCC23514MDWV</a>	Obsolete	Production	SOIC (DWV)   8	-	-	Call TI	Call TI	-40 to 125	23514M
<a href="#">UCC23514MDWVR</a>	Active	Production	SOIC (DWV)   8	1000   LARGE T&R	Yes	NIPDAU	Level-2-260C-1 YEAR	-40 to 125	23514M
<a href="#">UCC23514MDWVR.B</a>	Active	Production	SOIC (DWV)   8	1000   LARGE T&R	Yes	NIPDAU	Level-2-260C-1 YEAR	-40 to 125	23514M
<a href="#">UCC23514SDWV</a>	Obsolete	Production	SOIC (DWV)   8	-	-	Call TI	Call TI	-40 to 125	23514S
<a href="#">UCC23514SDWVR</a>	Active	Production	SOIC (DWV)   8	1000   LARGE T&R	Yes	NIPDAU	Level-2-260C-1 YEAR	-40 to 125	23514S
<a href="#">UCC23514SDWVR.B</a>	Active	Production	SOIC (DWV)   8	1000   LARGE T&R	Yes	NIPDAU	Level-2-260C-1 YEAR	-40 to 125	23514S
<a href="#">UCC23514VDWV</a>	Obsolete	Production	SOIC (DWV)   8	-	-	Call TI	Call TI	-40 to 125	23514V
<a href="#">UCC23514VDWVR</a>	Active	Production	SOIC (DWV)   8	1000   LARGE T&R	Yes	NIPDAU	Level-2-260C-1 YEAR	-40 to 125	23514V
<a href="#">UCC23514VDWVR.B</a>	Active	Production	SOIC (DWV)   8	1000   LARGE T&R	Yes	NIPDAU	Level-2-260C-1 YEAR	-40 to 125	23514V

(1) **Status:** For more details on status, see our [product life cycle](#).

(2) **Material type:** When designated, preproduction parts are prototypes/experimental devices, and are not yet approved or released for full production. Testing and final process, including without limitation quality assurance, reliability performance testing, and/or process qualification, may not yet be complete, and this item is subject to further changes or possible discontinuation. If available for ordering, purchases will be subject to an additional waiver at checkout, and are intended for early internal evaluation purposes only. These items are sold without warranties of any kind.

(3) **RoHS values:** Yes, No, RoHS Exempt. See the [TI RoHS Statement](#) for additional information and value definition.

(4) **Lead finish/Ball material:** Parts may have multiple material finish options. Finish options are separated by a vertical ruled line. Lead finish/Ball material values may wrap to two lines if the finish value exceeds the maximum column width.

(5) **MSL rating/Peak reflow:** The moisture sensitivity level ratings and peak solder (reflow) temperatures. In the event that a part has multiple moisture sensitivity ratings, only the lowest level per JEDEC standards is shown. Refer to the shipping label for the actual reflow temperature that will be used to mount the part to the printed circuit board.

(6) **Part marking:** There may be an additional marking, which relates to the logo, the lot trace code information, or the environmental category of the part.

Multiple part markings will be inside parentheses. Only one part marking contained in parentheses and separated by a "-" will appear on a part. If a line is indented then it is a continuation of the previous line and the two combined represent the entire part marking for that device.

**Important Information and Disclaimer:** The information provided on this page represents TI's knowledge and belief as of the date that it is provided. TI bases its knowledge and belief on information provided by third parties, and makes no representation or warranty as to the accuracy of such information. Efforts are underway to better integrate information from third parties. TI has taken and continues to take reasonable steps to provide representative and accurate information but may not have conducted destructive testing or chemical analysis on incoming materials and chemicals. TI and TI suppliers consider certain information to be proprietary, and thus CAS numbers and other limited information may not be available for release.

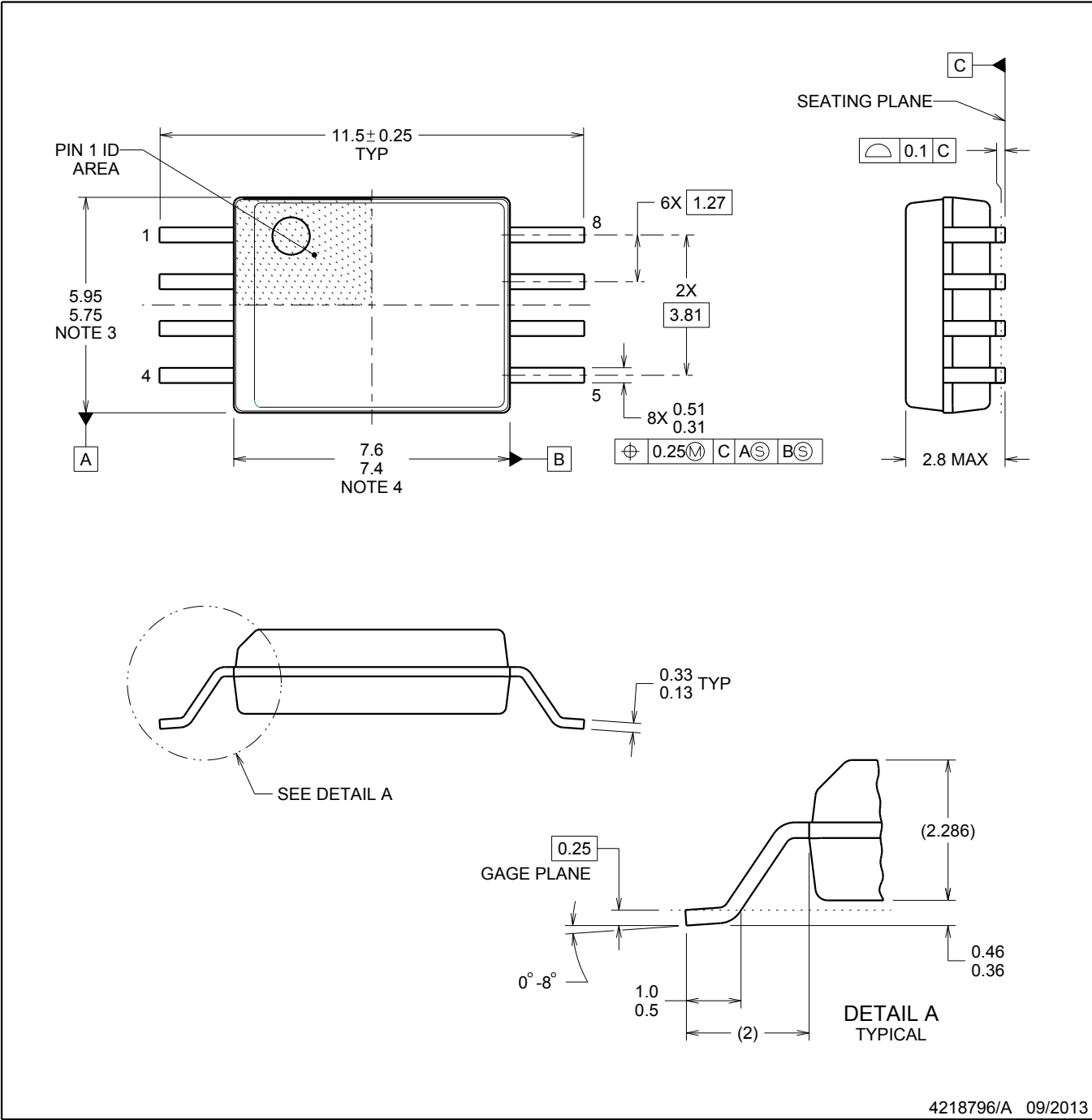
In no event shall TI's liability arising out of such information exceed the total purchase price of the TI part(s) at issue in this document sold by TI to Customer on an annual basis.



DWV0008A

SOIC - 2.8 mm max height

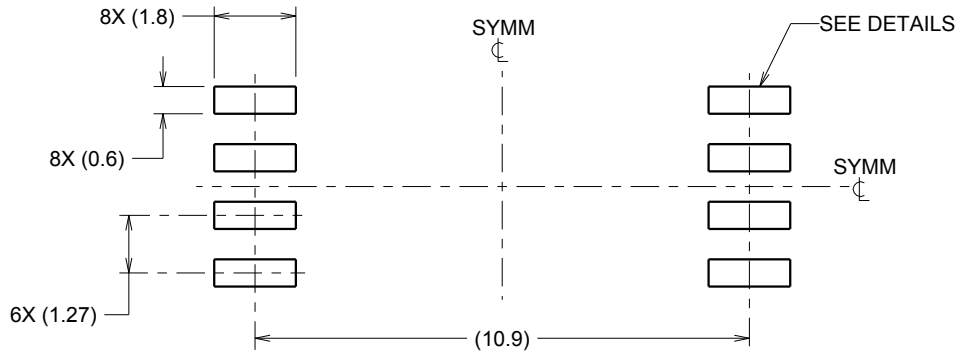
SOIC



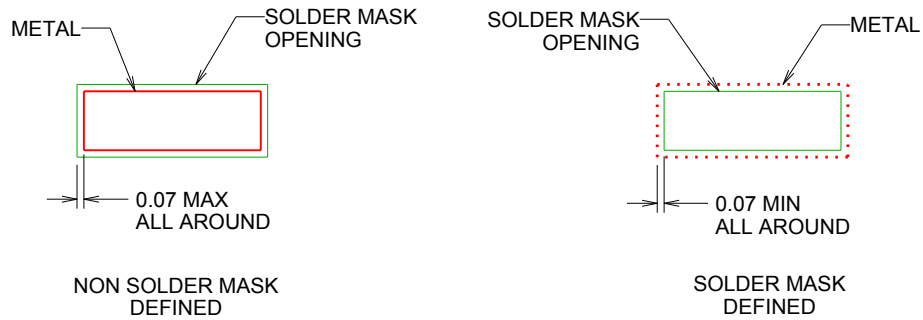
4218796/A 09/2013

NOTES:

- 1. All linear dimensions are in millimeters. Dimensions in parenthesis are for reference only. Dimensioning and tolerancing per ASME Y14.5M.
- 2. This drawing is subject to change without notice.
- 3. This dimension does not include mold flash, protrusions, or gate burrs. Mold flash, protrusions, or gate burrs shall not exceed 0.15 mm, per side.
- 4. This dimension does not include interlead flash. Interlead flash shall not exceed 0.25 mm, per side.



LAND PATTERN EXAMPLE  
 9.1 mm NOMINAL CLEARANCE/CREEPAGE  
 SCALE:6X

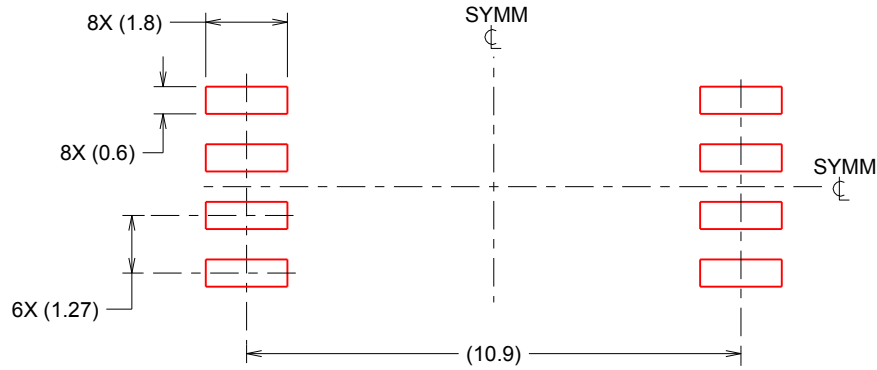


SOLDER MASK DETAILS

4218796/A 09/2013

NOTES: (continued)

- 5. Publication IPC-7351 may have alternate designs.
- 6. Solder mask tolerances between and around signal pads can vary based on board fabrication site.



SOLDER PASTE EXAMPLE  
 BASED ON 0.125 mm THICK STENCIL  
 SCALE:6X

4218796/A 09/2013

NOTES: (continued)

- 7. Laser cutting apertures with trapezoidal walls and rounded corners may offer better paste release. IPC-7525 may have alternate design recommendations.
- 8. Board assembly site may have different recommendations for stencil design.

## IMPORTANT NOTICE AND DISCLAIMER

TI PROVIDES TECHNICAL AND RELIABILITY DATA (INCLUDING DATA SHEETS), DESIGN RESOURCES (INCLUDING REFERENCE DESIGNS), APPLICATION OR OTHER DESIGN ADVICE, WEB TOOLS, SAFETY INFORMATION, AND OTHER RESOURCES "AS IS" AND WITH ALL FAULTS, AND DISCLAIMS ALL WARRANTIES, EXPRESS AND IMPLIED, INCLUDING WITHOUT LIMITATION ANY IMPLIED WARRANTIES OF MERCHANTABILITY, FITNESS FOR A PARTICULAR PURPOSE OR NON-INFRINGEMENT OF THIRD PARTY INTELLECTUAL PROPERTY RIGHTS.

These resources are intended for skilled developers designing with TI products. You are solely responsible for (1) selecting the appropriate TI products for your application, (2) designing, validating and testing your application, and (3) ensuring your application meets applicable standards, and any other safety, security, regulatory or other requirements.

These resources are subject to change without notice. TI grants you permission to use these resources only for development of an application that uses the TI products described in the resource. Other reproduction and display of these resources is prohibited. No license is granted to any other TI intellectual property right or to any third party intellectual property right. TI disclaims responsibility for, and you will fully indemnify TI and its representatives against, any claims, damages, costs, losses, and liabilities arising out of your use of these resources.

TI's products are provided subject to [TI's Terms of Sale](#) or other applicable terms available either on [ti.com](https://www.ti.com) or provided in conjunction with such TI products. TI's provision of these resources does not expand or otherwise alter TI's applicable warranties or warranty disclaimers for TI products.

TI objects to and rejects any additional or different terms you may have proposed.

Mailing Address: Texas Instruments, Post Office Box 655303, Dallas, Texas 75265

Copyright © 2025, Texas Instruments Incorporated